



Parker Hydraulic Threaded Cartridge Valves

Global Cartridge Valve Product Offerings



ENGINEERING YOUR SUCCESS.



WARNING - USER RESPONSIBILITY

FAILURE OR IMPROPER SELECTION OR IMPROPER USE OF THE PRODUCTS DESCRIBED HEREIN OR RELATED ITEMS CAN CAUSE DEATH, PERSONAL INJURY AND PROPERTY DAMAGE.

This document and other information from Parker-Hannifin Corporation, its subsidiaries and authorized distributors provide product or system options for further investigation by users having technical expertise.

The user, through its own analysis and testing, is solely responsible for making the final selection of the system and components and assuring that all performance, endurance, maintenance, safety and warning requirements of the application are met. The user must analyze all aspects of the application, follow applicable industry standards, and follow the information concerning the product in the current product catalog and in any other materials provided from Parker or its subsidiaries or authorized distributors.

To the extent that Parker or its subsidiaries or authorized distributors provide component or system options based upon data or specifications provided by the user, the user is responsible for determining that such data and specifications are suitable and sufficient for all applications and reasonably foreseeable uses of the components or systems.

OFFER OF SALE

The items described in this document are hereby offered for sale by Parker-Hannifin Corporation, its subsidiaries or its authorized distributor. This offer and its acceptance are governed by the provisions stated in the detailed "Offer of Sale" Available from your local Parker representative.

PLEASE READ

How to use this catalog...

• Product Index

Each product tab has its own product index for that particular section. Basic product specifications are shown along with catalog page numbers and product symbols. Further detail can be found on the specific catalog pages.

Catalog MSG15-3504						Check Valves		CV SH LM FC PC
SERIES	CAVITY	DESCRIPTION	FLOW LPM/GPM	PRESSURE BAR/PSI	PAGE NO.			
Technical Tips						C02-C03		
STANDARD CHECKS								
CM21		Sense Check Valve	3.871	350/5000	C04			
D1880	20	Check Valve Insert, Ball Type	14208	420/6000	C05			
D1825	20	Check Valve Insert, Ball Type	4501/2	420/6000	C06			
D028P	C08-2	Cartridge Check, Ball Type	45/12	420/6000	C07			
CM28P	C08-2	Cartridge Check, Poppet Type	28/10	350/5000	C08			
CM123P	C10-2	Cartridge Check, Poppet Type	60/16	350/5000	C09			
CM42P	C10-2	Cartridge Check, Ball Type	180/42	420/6000	C10			
CM121P	C10-2	Cartridge Check, Poppet Type	12/32	350/5000	C11			
D088P	C16-2	Cartridge Check, Poppet Type	280/74	420/6000	C12			
CM181P	C16-2	Cartridge Check, Poppet Type	250/60	350/5000				
CM201P	C20-2	Cartridge Check, Poppet Type						
PILOT OPERATED CHECK								

• Technical Tips

At the beginning of each product section, we have a series of **Technical Tip** pages. These pages describe, in detail, the application and operational parameters of our cartridge valves. If you have any application or specification questions that cannot be answered by this section, please contact your local Parker representative or give us a call.

Catalog MSG15-3504

Technical Tips

Proportional Valves

PRODUCT TYPES / APPLICATIONS
Proportional valves are nothing more than electrically adjustable hydraulic valves. They give the operator nearly infinite adjustment control and flexibility. Parker Hannifin offers various types of proportional flow control, pressure reducing, and relief valves.

Proportional Flow Control Valve
Proportional flow control valves provide pseudo pressure compensation and are used on systems requiring variable electronic control of flow. They allow the operator to vary the control signal to accelerate or decelerate an actuator. A compensator valve can be added to the circuit for enhanced compensation. Some typical applications would include the hoist control for a lift, or the speed control for a winch circuit. Parker offers both normally closed and normally open versions of proportional flow control.

Normally Closed Proportional Flow Control

OPERATION - With the solenoid coil de-energized, the spool is held in a closed position by the spring force. When the solenoid is energized, the ampereage of the coil overcomes the spring force and the spool moves to an open position.

• Product Pages

The individual product catalog pages detail fully the product specifications and operating parameters of each valve. Additionally, dimensional information, as well as a complete model code for ordering product is shown.

Catalog MSG15-3504

Product Information

Sense Check Valve Series CVH021

General Description
Cartridge Style Sense Check Valve. For additional information see Technical Tips on pages CV2-CV3.

Features

- Rapid response to load direction changes
- Hardened precision parts for durability
- Insert style design for location within manifolds under SAE-6 or larger port

Performance Curve
Pressure Drop vs. Flow

Dimensions Millimeters (inch)

• Coil and Body

There are 2 sections in this catalog that assist you in selecting the proper valve body or solenoid coil for your particular application. Also, the cavity details are shown for all Parker cavities currently in use.

Catalog MSG15-3504

Product Information

Super Coil Series 1/2" I.D.

Features

- Integral Deutsch connector coil exceeds IP98K standards
- Integral Deutsch connector coil thermal shock dunk test rated
- Universal 50/60 Hz operation
- Waterproof coil hermetically sealed, requires no O-rings or waterproofing kits
- External plated steel flow-carrying band (unlike encapsulated band) enables coil to withstand severe thermal shocks without cracking
- Symmetrical coil can be reversed without affecting performance

Specifications

Coil Type	S	Standard
	P	Puissant
Max. Voltage	S	14 Watts
	P	10 Watts

Ordering Information

Super Coil 1/2" I.D. Voltage Termination

Code Voltage
S Standard
P Puissant

• Technical Data

The Technical Data section outlines various hydraulic guidelines such as ratings, torques, limitations in use, seals, and hydraulic fluid/filtration information.

Catalog MSG15-3504

Technical Data

Threaded Cartridge Valves and Integrated Hydraulic Products

INTRODUCTION
In this section you will find a variety of technical information pertinent to general hydraulics as well as cartridge valve technology.

HYDRAULIC FORMULAS
Below are a few of the common hydraulic formulas to assist you in calculating the requirements for your system:

Flow = Current × Resistance
Flow = Volume ÷ Unit of Time
Pressure = Force ÷ Area
Horsepower = Flow × Pressure ÷ (1714 × Efficiency)

Hydraulic power (kW) = $\frac{\Delta p \text{ (Bar)} \times \text{flow rate (LPM)}}{600}$
where Δp = pressure drop

VISCOSITY
Catalog data is from tests conducted on mineral oil at a viscosity of 32 cSt (150 SSU) using an ISO 32 fluid at 100 degrees F.
Product should ideally be used at viscosities in the range of 15 to 50 cSt (80 to 230 SSU).
Product will perform with reduced efficiency in the ranges, 5 to 15 cSt (42 to 80 SSU) and 50 to 500 cSt (230 to 2300 SSU). These extreme conditions must be evaluated by the user to establish suitability of the product's performance.

PRESSURE RATINGS
Unless otherwise stated, all Parker cartridges have a continuous duty pressure rating as shown in the catalog. All pressure ratings are based on the cartridge valve only. Exposure to elevated pressures may affect the performance and fatigue life of the product. The material chosen for the body or carrier may affect the pressure rating we recommend. Parker does not recommend the use of...



Check Valves	CV1-CV19	CV Check Valves
Shuttle Valves	SH1-SH6	SH Shuttle Valves
Load and Motor Control Valves	LM1-LM33	LM Load/Motor Controls
Flow Control Valves	FC1-FC29	FC Flow Controls
Pressure Control Valves	PC1-PC59	PC Pressure Controls
Logic Element Valves	LE1-LE17	LE Logic Elements
Directional Control Valves	DC1-DC5	DC Directional Controls
Solenoid Valves	SV1-SV64	SV Solenoid Valves
Proportional Valves	PV1-PV32	PV Proportional Valves
Coils and Electronics	CE1-CE9	CE Coils & Electronics
Bodies and Cavities	BC1-BC39	BC Bodies & Cavities
Technical Data	TD1-TD4	TD Technical Data

SERIES	DESCRIPTION	PAGE NO.	SERIES	DESCRIPTION	PAGE NO.
16SLC1-A	Normally Closed, Pilot to Close	LE9	GP02 51	4 Way, 3 Pos - Closed Center	PV26-PV27
20SLC1-A	Normally Closed, Pilot to Close	LE10	GP02 52	4 Way, 3 Pos - Closed Center	PV26-PV27
A04B2	Direct Acting Relief, Poppet Type	PC16-PC17	GP02 53	4 Way, 3 Pos - Closed Center	PV28-PV29
A04J2	Direct Acting, Cross-over Relief	PC34-PC35	GP02 54	4 Way, 3 Pos - Closed Center	PV28-PV29
AP02B2YP	Increase Pressure/Increase Current	PV6-PV7	GS02 51	3 Position, 4 Way	SV47-SV48
AP02B2YR	Decrease Pressure/Increase Current	PV10-PV11	GS02 53	3 Position, 4 Way	SV49-SV50
AP04G2YP	Increase Pressure/Increase Current	PV8-PV9	GS02 57	3 Position, 4 Way	SV51-SV52
AP04G2YR	Decrease Pressure/Increase Current	PV12-PV13	GS02 59	3 Position, 4 Way	SV53-SV54
CB101	Load Control Cartridge Valve	LM12-LM13	GS02 81	Bi-Directional Poppet N.C.	SV19-SV20
CDPH103	Dual P.O. Check Package	CV17-CV18	GS02 86	Bi-Directional Poppet N.O.	SV25-SV26
CPD084P	Dual P.O. Check Cartridge	CV19	GS04 52D	3 Position, 4 Way	SV57-SV58
CPH104P	Single P.O. Check, Pilot on Port 1	CV15	GS04 54D	3 Position, 4 Way	SV59-SV60
CPH124P	Single P.O. Check, Pilot on Port 1	CV16	GS04 57D	3 Position, 4 Way	SV61-SV62
CSH041	Cartridge Shuttle	SH4	GS04 59D	3 Position, 4 Way	SV63-SV64
CSH101B	Cartridge Shuttle	SH5	GS04 81	Bi-Directional Poppet N.C.	SV21-SV22
CVH021	Sense Check Valve	CV4	GS04 86	Bi-Directional Poppet N.O.	SV27-SV28
CVH081P	Cartridge Check, Poppet Type	CV8	GS06 81	Bi-Directional Poppet N.C.	SV23-SV24
CVH103P	Cartridge Check, Poppet Type	CV9	GS06 86	Bi-Directional Poppet N.O.	SV29-SV30
CVH121P	Cartridge Check, Poppet Type	CV11	J02D3	Priority Type, with Bypass	FC20-FC21
CVH161P	Cartridge Check, Poppet Type	CV13	J02E2	Restrictive Flow Control, Adjustable	FC12-FC13
CVH201P	Cartridge Check, Poppet Type	CV14	J04D3	Priority Type, with Bypass	FC22-FC23
D02B2	Cartridge Check, Ball Type	CV7	J04E2	Restrictive Flow Control, Adjustable	FC14-FC15
D04B2	Cartridge Check, Ball Type	CV10	J1A125	Priority Type, with Bypass	FC24-FC25
D06B2P	Cartridge Check, Poppet Type	CV12	JP02C	Flow Control, N.C.	PV18-PV19
D1A060	Check Valve Insert, Ball Type	CV5	JP02P	Flow Control, N.O.	PV22-PV23
D1B125	Check Valve Insert, Ball Type	CV6	JP04C 21	Flow Control, N.C.	PV20-PV21
DH103	3 Way, External Pilot, Normally Open, Vent to Atmosphere	DC2-DC3	JP04C 31	Priority Flow Control, N.C.	PV24-PV25
DSH081	2 Position, 2 Way, N.C. or N.O.	SV7-SV8	K04C3	Spool Type, Spring Centered, All Ports Closed	SH6
DSH082	2 Position, 2 Way	SV31-SV32	KSWA3	Ball Insert Type	SH3
DSH083	2 Position, 3 Way	SV35-SV37	L04A3	Flow Divider/Combiner	FC26-FC27
DSH084	2 Position, 4 Way	SV41-SV42	L06A3	Flow Divider/Combiner	FC28-FC29
DSH101	2 Position, 2 Way, N.C. or N.O.	SV9-SV10	LE101A (NEW)	Normally Closed, Pilot to Close	LE8
DSH102	2 Position, 2 Way	SV33-SV34	LE102A (NEW)	Normally Closed, Pilot to Close	LE11
DSH103	2 Position, 3 Way	SV38-SV40	LE102B (NEW)	Normally Closed, Vent to Open	LE14
DSH104	2 Position, 4 Way	SV43-SV44	LE103A (NEW)	Normally Open, Vent to Close	LE15
DSH121	2 Position, 2 Way, N.C. or N.O.	SV11-SV12	LE103B (NEW)	Normally Open, Vent to Close	LE17
DSH161	2 Position, 2 Way, N.C. or N.O.	SV13-SV14	MHC-010-S***	Load Control Cartridge Valve	LM14-LM15
DSH164	2 Position, 4 Way	SV45-SV46	N5A125	3 Way, 2 Position, External Drain, Open Transition	DC4
DSL087 (NEW)	Bi-Directional Poppet, N.C. or N.O.	SV17-SV18	N5A300	3 Way, 2 Position, External Drain, Open Transition	DC5
DSL105	3 Position, 4 Way	SV55-SV56	NVH081	Needle Valve, Cartridge Type	FC6-FC7
DSL201	2 Position, 2 Way, N.C. or N.O.	SV15-SV16	NVH101	Needle Valve, Cartridge Type	FC8-FC9
DSP105C1	3 Position, 4 Way - Closed Center	PV30-PV32	PR103	Direct Acting Reducing/Relieving	PC48-PC49
DSP105C4	3 Position, 4 Way - Float Center	PV30-PV32	PRH081	Pilot Operated Reducing/Relieving	PC54-PC55
E2*020	Load Control Cartridge Valve	LM16-LM17	PRH082	Pilot Operated Reducing	PC50-PC51
E2*040	Load Control Cartridge Valve	LM18-LM19	PRH101	Pilot Operated Reducing/Relieving	PC56-PC57
E2*060	Load Control Cartridge Valve	LM20-LM21	PRH102	Pilot Operated Reducing	PC52-PC53
E2*125	Load Control Cartridge Valve	LM22-LM23	PRH161	Pilot Operated Reducing/Relieving	PC58-PC59
E2*300	Load Control Cartridge Valve	LM24-LM25	R06E3	Normally Closed, Pilot to Close	LE12
E6B020	Load Control Cartridge Valve, 4.5:1 Ratio	LM26-LM27	R06H3	Normally Open, Vent to Close	LE16
E6B040	Load Control Cartridge Valve, 3:1 Ratio	LM30-LM31	R08E3	Normally Closed, Pilot to Close	LE13
E6B060*409	Load Control Cartridge Valve, 3:1 Ratio	LM32-LM33	RAH081	Pilot Operated Spool Type	PC24-PC25
E6K020	Load Control Cartridge Valve, 15:1 Ratio	LM28-LM29	RAH101	Pilot Operated Spool Type	PC26-PC27
EPR083R	Pressure Reducing/Relieving Valve	PV14-PV15	RAH121	Pilot Operated Spool Type	PC28-PC29
EPR111C	Pressure Reducing/Relieving Valve	PV16-PV17	RAH161	Pilot Operated Spool Type	PC30-PC31
E2*1 (NEW)	Load Control Cartridge Valve	LM6-LM7	RAH201	Pilot Operated Spool Type	PC32-PC33
E2*1R (NEW)	Load Control Cartridge Valve	LM8-LM9	RD102	Direct Acting Relief, Poppet Type	PC14-PC15
E2*1S (NEW)	Load Control Cartridge Valve	LM10-LM11	RD163	Direct Acting Differential Area Relief	PC22-PC23
FA101	Restrictive Flow Control, Reverse Check, Adjustable	FC16-FC17	RDH081	Direct Acting Relief, Ball Type	PC8-PC9
FC101	Restrictive Flow Control, Reverse Check, Tuneable	FC18-FC19	RDH082	Direct Acting Relief, Poppet Type	PC10-PC11
FV101	Needle Valve with Reverse Check, 1 to 2 Free Flow	FC10-FC11	RDH083	Direct Acting Differential Area Relief	PC18-PC19
FV102	Needle Valve with Reverse Check, 1 to 2 Free Flow	FC10-FC11	RDH101	Direct Acting Relief, Ball Type	PC12-PC13
			RDH103	Direct Acting Differential Area Relief	PC20-PC21
			RU104	Direct Acting Unloading	PC36-PC37

CV
Check Valves
SH
Shuttle Valves
LM
Load/Motor Controls
FC
Flow Controls
PC
Pressure Controls
LE
Logic Elements
DC
Directional Controls
SV
Solenoid Valves
PV
Proportional Valves
CE
Coils & Electronics
BC
Bodies & Cavities
TD
Technical Data



SERIES	DESCRIPTION	PAGE NO.
SVH081	Pilot Operated, Int. Pilot, Ext. Drain.....	PC38-PC39
SVH101	Pilot Operated, Int. Pilot, Ext. Drain.....	PC40-PC41
SVH102	Pilot Operated, Ext. Pilot, Int. Drain.....	PC44-PC45
SVH161	Pilot Operated, Int. Pilot, Ext. Drain.....	PC42-PC43
SVH162	Pilot Operated, Ext. Pilot, Int. Drain.....	PC46-PC47

Cartridge Valve Coils

CC	1/2" Solenoid Tubes.....	CE4-CE5
CA	5/8" Solenoid Tubes.....	CE6-CE7
SW7L	1/2" Proportional Tube - Short.....	CE8-CE9

Standard Bodies and Cavities

C04-3	04 Size, 3 Way.....	BC4
C08-2	08 Size, 2 Way.....	BC5
C08-3	08 Size, 3 Way.....	BC6
C08-3L	08 Size, 3 Way, Long.....	BC7
C08-4	08 Size, 4 Way.....	BC8
C10-2	10 Size, 2 Way.....	BC9
C10-3	10 Size, 3 Way.....	BC10
C10-3L	10 Size, 3 Way, Long.....	BC11
C10-3S	10 Size, 3 Way, Short.....	BC12
C10-4	10 Size, 4 Way.....	BC13
C12-2	12 Size, 2 Way.....	BC14
C12-3	12 Size, 3 Way.....	BC15
C16-2	16 Size, 2 Way.....	BC16
C16-3	16 Size, 3 Way.....	BC17
C16-3S	16 Size, 3 Way, Short.....	BC18
C16-4	16 Size, 4 Way.....	BC19
C20-2	20 Size, 2 Way.....	BC20
C20-3S	20 Size, 3 Way, Short.....	BC21

Counterbalance Cavities and Bodies

MHC-010	Single and Dual Counterbalance Bodies.....	BC22
---------	--	------

Pilot Piston Cavities

10 Size	10 Size Cavity for Dual Check and Pilot Piston.....	BC23
---------	---	------

Special Bodies and Cavities

CAVOW-2	2 Port.....	BC24
CAVSW-3	3 Port.....	BC25
CAVT11A	3 Port.....	BC26
2C	2 Port.....	BC27
2R	2 Port.....	BC28
2U	2 Port.....	BC29
3A	3 Port.....	BC30
3C	3 Port.....	BC31
3K	3 Port.....	BC32
3M	3 Port.....	BC33
3X	3 Port.....	BC34
4C	4 Port.....	BC35
5A	5 Port.....	BC36
53-1	3 Port.....	BC37
68-1	3 Port.....	BC38
100-1	5 Port.....	BC39

Technical Data

Basic Hydraulic Formulas.....	TD2
Ratings and Testing.....	TD2
Temperature Ratings.....	TD2
Viscosity.....	TD2
Pressure Ratings.....	TD2
Thermal Shock.....	TD2
Service and Components.....	TD2
Limitations in Use.....	TD2
Seal Material Selection.....	TD3
Hydraulic Fluids.....	TD4
Hydraulic Filtration.....	TD4
Application of Product.....	TD4

CV
Check Valves
SH
Shuttle Valves
LM
Load/Motor Controls
FC
Flow Controls
PC
Pressure Controls
LE
Logic Elements
DC
Directional Controls
SV
Solenoid Valves
PV
Proportional Valves
CE
Coils & Electronics
BC
Bodies & Cavities
TD
Technical Data

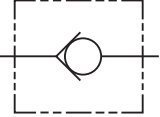
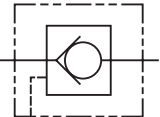
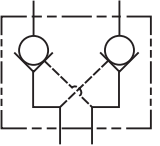

SERIES	CAVITY	DESCRIPTION	FLOW LPM/GPM	PRESSURE BAR/PSI	PAGE NO.
Technical Tips.....					CV2-CV3
STANDARD CHECKS					
		CVH021 Sense Check Valve.....	3.8/1	350/5000	CV4
		D1A060 2U..... Check Valve Insert, Ball Type.....	145/38	420/6000	CV5
		D1B125 2C..... Check Valve Insert, Ball Type.....	500/132	420/6000	CV6
		D02B2 C08-2 Cartridge Check, Ball Type.....	45/12	420/6000	CV7
		CVH081P C08-2 Cartridge Check, Poppet Type.....	38/10	350/5000	CV8
		CVH103P C10-2 Cartridge Check, Poppet Type.....	60/16	350/5000	CV9
		D04B2 C10-2 Cartridge Check, Ball Type.....	160/42	420/6000	CV10
		CVH121P C12-2 Cartridge Check, Poppet Type.....	121/32	350/5000	CV11
		D06B2P C16-2 Cartridge Check, Poppet Type.....	280/74	420/6000	CV12
		CVH161P C16-2 Cartridge Check, Poppet Type.....	226/60	350/5000	CV13
		CVH201P C20-2 Cartridge Check, Poppet Type.....	303/80	350/5000	CV14
PILOT OPERATED CHECKS					
		CPH104P C10-3 Single P.O. Check, Pilot on Port 1.....	30/8	350/5000	CV15
		CPH124P C12-3 Single P.O. Check, Pilot on Port 1.....	75/20	350/5000	CV16
DUAL PILOT OPERATED CHECKS					
		CDPH103..... Dual P.O. Check Package.....	60/16	350/5000	CV17-CV18
		CPD084P C08-4 Dual P.O. Check Cartridge.....	19/5	207/3000	CV19

CV
Check Valves

SH
Shuttle Valves

LM
Load/Motor Controls

FC
Flow Controls

PC
Pressure Controls

LE
Logic Elements

DC
Directional Controls

SV
Solenoid Valves

PV
Proportional Valves

CE
Coils & Electronics

BC
Bodies & Cavities

TD
Technical Data

INTRODUCTION:

This technical tips section is designed to help familiarize you with the Parker line of Check Valves. In this section we present the products that are new to this catalog as well as some design features of our checks valves. In addition, we present common options available to help you in selecting products for your application. Finally we give a brief synopsis of the operation and applications of the various product offered in this section.

NEW PRODUCTS:

There are several new additions and product improvements to our Check Valve product line.

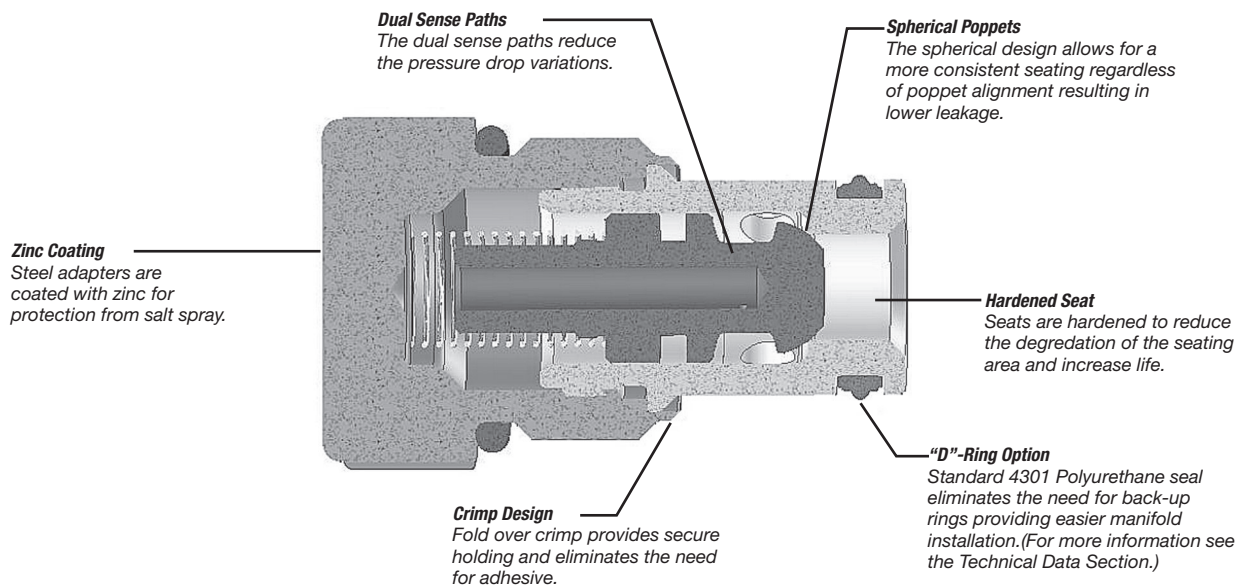

COMMON OPTIONS:

Since check valves and shuttles are fairly simple components, there are very few options. Here are the standard options you will find.

Seals: Valves feature a 4301 Polyurethane "D"-Ring. The "D"-Ring eliminates the need for back-up rings. The majority of the products are also available in Nitrile or Fluorocarbon seals. Contact factory for availability.

You should match the seal compatibility to the temperature and fluid being used in your application.

Crack Pressure: Parker offers a number of standard crack pressure options for each valve. Check the model code pages for these options. The crack pressure is defined as the minimum amount of pressure that is needed to unseat the poppet. In pilot operated check applications, you may want to go with a slightly higher cracking pressure to keep the piston weight, friction, and drag from accidentally unseating the poppet.

Pilot Piston Seal: On the pilot piston style pilot operated check valves, Parker offers the option to place a seal on the piston to reduce the leakage across the piston.

Note: Sealing the pilot piston does not decrease the leakage across the poppet. In other words, if you are trying to reduce the leakage from the actuator port, sealing the piston will not help. While most applications do not require a seal on the piston, it can be advantageous in applications with very small pump flows where the lost fluid would have a high impact on actuator speed.

PRODUCT TYPES / APPLICATIONS

Check Valve - Poppet Type

Check valves are poppet style elements that allow free flow in one direction while preventing flow in the reverse direction.

They can be used to isolate portions of a hydraulic circuit or to provide a free flow path around a restrictive valve.

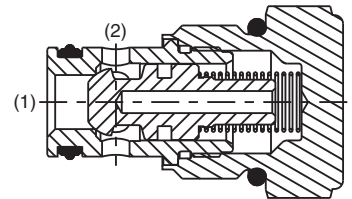
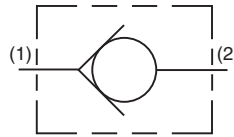

OPERATION - Pressure on the inlet (port 1) of the check valve creates a force against the poppet, pushing it off its seat and permitting free flow to port 2. Reverse flow through the check is blocked by the poppet.

Check Valve - Ball Type

Ball type check valves are check valves that use a hardened steel ball to seal against the valve seat as opposed to a poppet. They are simple in their design and provide low leakage over the life of the system.

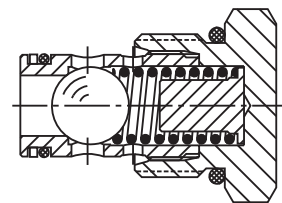
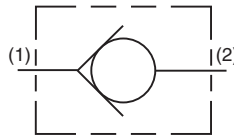

OPERATION - Pressure on the inlet (port 1) of the check valve creates a force on the steel ball pushing it off of its seat and permitting free flow to port 2. Reverse flow through the check is blocked by the steel ball on the seat.

Pilot Operated Check Valve

Parker's reliable pilot piston style P.O. check valves are designed for critical applications where safety and load holding is required and flows from 19 to 150 lpm (5 to 40 gpm) and pressures up to 420 bar (6,000 psi) are needed. These valves are available with pilot supply to either the 1st port or 3rd port depending on circuit need, and are generally used in conjunction with linear actuators across several markets within mobile or industrial hydraulics, such as aerials, material handling, and construction where durable and low leak valves are necessary to keep the machinery and operators safe.

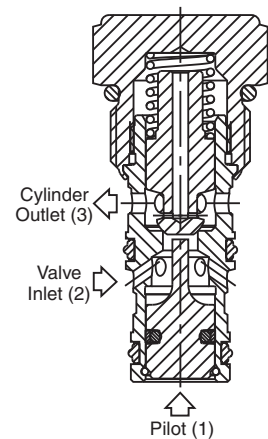
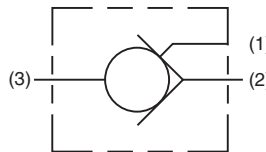

OPERATION - Pilot operated check valves, also known as P.O. checks, are used to lock a cylinder in a holding position with minimal leakage or drift. P.O. check valves that can be opened to allow flow in the reverse direction with an external signal to the pilot port. The valves work best when used in conjunction with a control valve that vents the valve ports to tank when centered. Pilot pressure to open the checks for reverse flow is a ratio of the holding pressure, and are typically 3:1 or 4:1. A 3:1 ratio with a 3000psi load requires a 1000psi signal to the pilot port.

CV
Check Valves

SH
Shuttle Valves

LM
Load/Motor Controls

FC
Flow Controls

PC
Pressure Controls

LE
Logic Elements

DC
Directional Controls

SV
Solenoid Valves

PV
Proportional Valves

CE
Coils & Electronics

BC
Bodies & Cavities

TD
Technical Data

General Description

Cartridge Style Sense Check Valve.
 For additional information see Technical Tips on pages CV2-CV3.

Features

- Rapid response to load direction changes
- Hardened precision parts for durability
- **Insert style design for location within manifolds under SAE-6 or larger port**

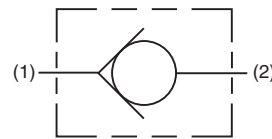
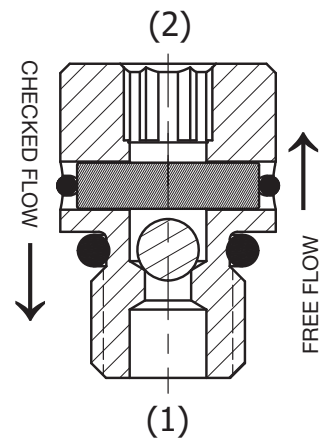

Performance Curve

Pressure Drop vs. Flow

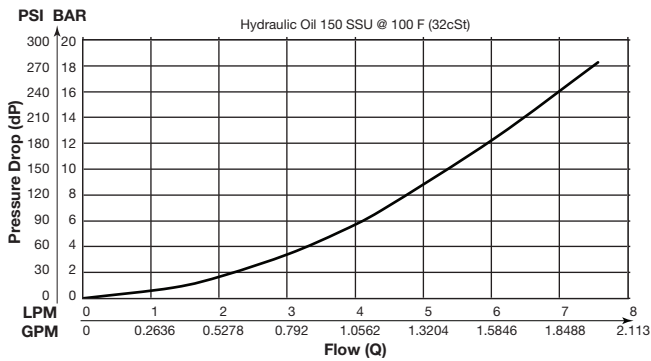

Dimensions Millimeters (Inches)

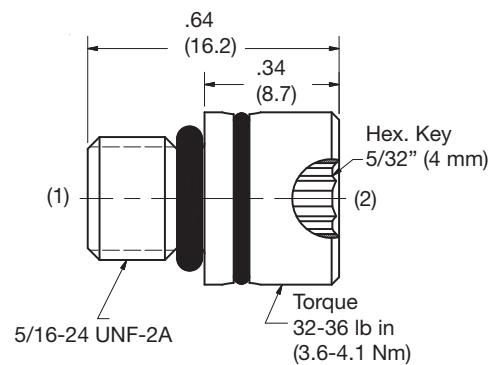

Specifications

Rated Flow	3.8 LPM (1 GPM)
Maximum Inlet Pressure	350 Bar (5000 PSI)
Leakage at 150 SSU (32 cSt)	15 ml/min.
Cartridge Material	Steel operating parts hardened steel ball.
Operating Temp. Range/Seals	-26°C to +204°C (Fluorocarbon) (-15°F to +400°F)
Fluid Compatibility/Viscosity	Mineral-based or synthetic with lubricating properties at viscosities of 45 to 2000 SSU (6 to 420 cSt)
Filtration	ISO-4406 18/16/13, SAE Class 4
Approx. Weight	0.02 kg (0.045 lbs.)

Ordering Information

CVH021

Size 02 Sense Check Valve

CV
Check Valves

SH
Shuttle Valves

LM
Load/Motor Controls

FC
Flow Controls

PC
Pressure Controls

LE
Logic Elements

DC
Directional Controls

SV
Solenoid Valves

PV
Proportional Valves

CE
Coils & Electronics

BC
Bodies & Cavities

TD
Technical Data

General Description

Ball Type, Check Valve Insert.
 For additional information see Technical Tips on pages CV2-CV3.

Features

- For inserting inside manifold blocks
- High flow capacity
- Minimal leakage - less than 3 drops/min.
- Simple construction - extremely cost effective
- Good contamination tolerance

Performance Curve

Pressure Drop vs. Flow (Through cartridge only)

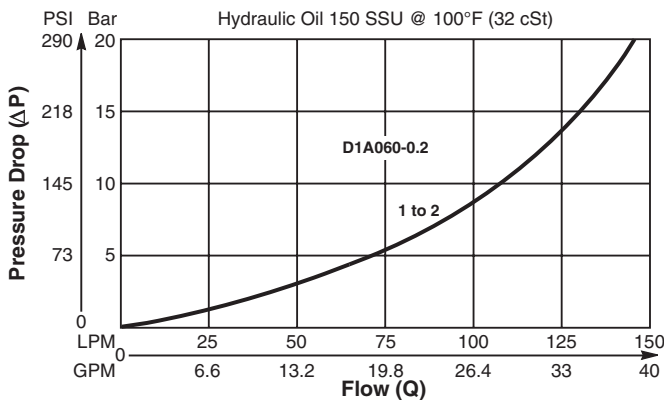

Specifications

Rated Flow	145 LPM (38 GPM)
Nominal Flow @ 7 Bar (100 PSI)	90 LPM (24GPM)
Maximum Inlet Pressure	420 Bar (6000 PSI)
Leakage at 150 SSU (32 cSt)	Less than 3 drops/min.
Cartridge Material	Steel operating parts hardened steel ball.
Operating Temp. Range/Seals	-34°C to +121°C (Nitrile) (-30°F to +250°F) -26°C to +204°C (Fluorocarbon) (-15°F to +400°F)
Fluid Compatibility/Viscosity	Mineral-based or synthetic with lubricating properties at viscosities of 45 to 2000 SSU (6 to 420 cSt)
Filtration	ISO-4406 18/16/13, SAE Class 4
Approx. Weight	0.85 kg (0.19 lbs.)
Cavity	2U (See BC Section for more details)

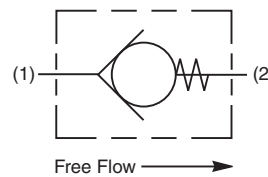
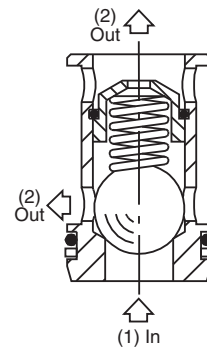

Dimensions Millimeters (Inches)

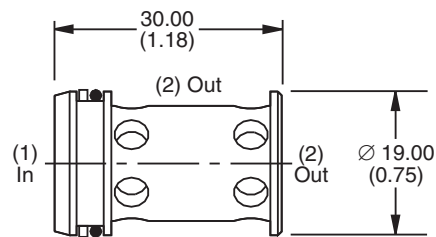

Ordering Information

D1A060	0.2	N
Check Valve Insert	Cracking Pressure	Seals

Highlighted represents preferred options that offer the shortest lead times. Other options may be available, but at extended lead times.

Code	Cracking Pressure
0.2	0.2 Bar (3 PSI) Std.

Code	Seals
N	Nitrile

Kit	Part Number
Nitrile Seal	SK30019N-1
Fluorocarbon Seal	SK30019V-1

CV	Check Valves
SH	Shuttle Valves
LM	Load/Motor Controls
FC	Flow Controls
PC	Pressure Controls
LE	Logic Elements
DC	Directional Controls
SV	Solenoid Valves
PV	Proportional Valves
CE	Coils & Electronics
BC	Bodies & Cavities
TD	Technical Data

General Description

Poppet Type, Check Valve Insert.
 For additional information see Technical Tips on pages CV2-CV3.

Features

- For inserting inside manifold blocks
- High Stable flow capacity (Contact the Factory for Highly dynamic application)
- Minimal leakage - less than 3 drops/min.
- Simple construction - extremely cost effective
- Good contamination tolerance
- Alternative 1"SAE or 1"BSP Retainer available separately

Performance Curve

Pressure Drop vs. Flow (Through cartridge only)

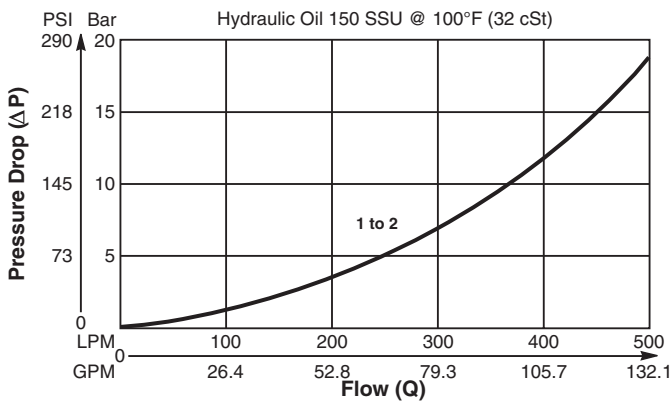

Specifications

Rated Flow	500 LPM (132 GPM)
Nominal Flow @ 7 Bar (100 PSI)	300 LPM (79GPM)
Maximum Inlet Pressure	420 Bar (6000 PSI)
Leakage at 150 SSU (32 cSt)	Less than 3 drops/min.
Cartridge Material	Steel operating parts hardened steel poppet.
Operating Temp. Range/Seals	-34°C to +121°C (Nitrile Buna-N) (-30°F to +250°F) -26°C to +204°C (Fluorocarbon) (-15°F to +400°F)
Fluid Compatibility/Viscosity	Mineral-based or synthetic with lubricating properties at viscosities of 45 to 2000 SSU (6 to 420 cSt)
Filtration	ISO-4406 18/16/13, SAE Class 4
Approx. Weight	0.6 kg (0.13 lbs.)
Cavity	2C (See BC Section for more details)

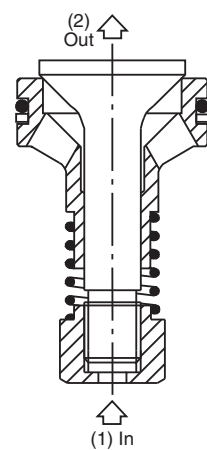
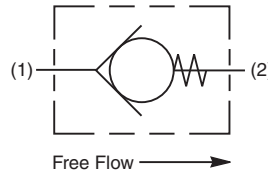

Dimensions Millimeters (Inches)

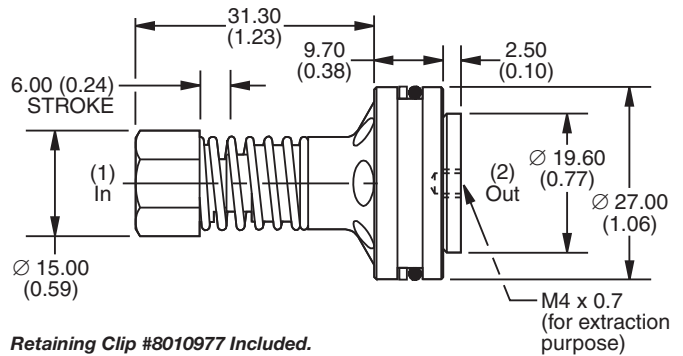

Retaining Clip #8010977 Included.

Ordering Information

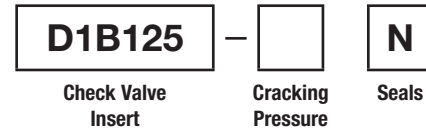

Highlighted represents preferred options that offer the shortest lead times. Other options may be available, but at extended lead times.

Code	Cracking Pressure
0.2	0.2 Bar (3 PSI)
1.0	1.0 Bar (15 PSI) Std.
5.0	5.0 Bar (72 PSI)

Code	Seals
N	Nitrile

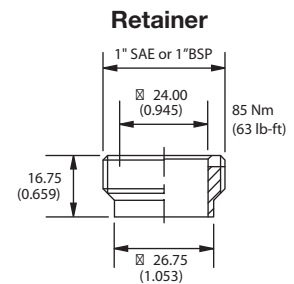

Kit	Part Number
Threaded Retainer (1"SAE)	RT10002
Threaded Retainer (1"BSP)	RT10001
Nitrile Seal	SK30014N-1
Fluorocarbon Seal	SK30014V-1

CV	Check Valves
SH	Shuttle Valves
LM	Load/Motor Controls
FC	Flow Controls
PC	Pressure Controls
LE	Logic Elements
DC	Directional Controls
SV	Solenoid Valves
PV	Proportional Valves
CE	Coils & Electronics
BC	Bodies & Cavities
TD	Technical Data

General Description

Ball Type Check Valve.
 For additional information see Technical Tips on pages CV2-CV3.

Features

- Low leakage - less than 3 drops/min.
- Ball type construction for cost effective design
- Single and dual pilot pistons available to create pilot to open check
- Range of cracking pressures available - up to 25 Bar (362 PSI)
- Good contamination tolerance
- All external parts zinc plated

Performance Curve

Pressure Drop vs. Flow (Through cartridge only)

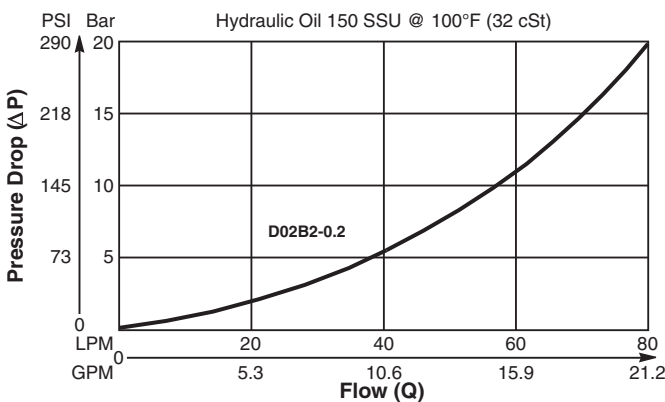

Specifications

Rated Flow	80 LPM (21 GPM)
Nominal Flow @ 7 Bar (100 PSI)	45 LPM (12GPM)
Maximum Inlet Pressure	420 Bar (6000 PSI)
Leakage at 150 SSU (32 cSt)	Less than 3 drops/min.
Cartridge Material	Steel operating parts hardened steel ball.
Operating Temp. Range/Seals	-34°C to +121°C (Nitrile Buna-N) (-30°F to +250°F) -26°C to +204°C (Fluorocarbon) (-15°F to +400°F)
Fluid Compatibility/Viscosity	Mineral-based or synthetic with lubricating properties at viscosities of 45 to 2000 SSU (6 to 420 cSt)
Filtration	ISO-4406 18/16/13, SAE Class 4
Approx. Weight	0.05 kg (0.11 lbs.)
Cavity	C08-2 (See BC Section for more details)

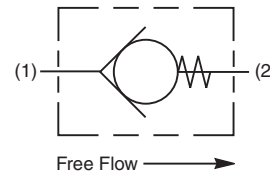
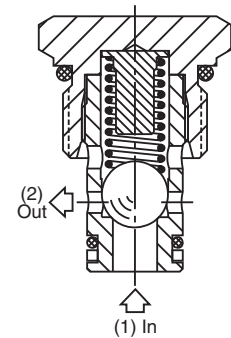

Dimensions

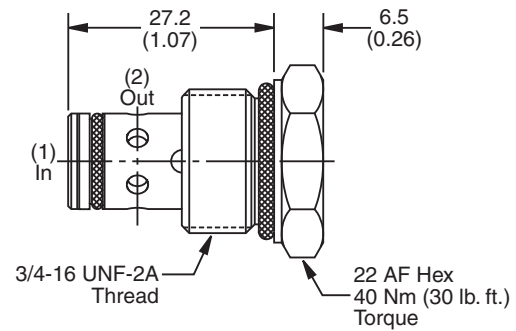

Ordering Information

D02B2 — **N**

Ball Type Check Valve Cracking Pressure Seals

Highlighted represents preferred options that offer the shortest lead times. Other options may be available, but at extended lead times.

Code	Cracking Pressure
0.2	0.2 Bar (3 PSI) Std.
1.0	1.0 Bar (15 PSI)
2.1	2.1 Bar (30 PSI)
3.4	3.4 Bar (50 PSI)
6.0	6.0 Bar (87 PSI)

Code	Seals
N	Nitrile

Kit	Part Number
Nitrile Seal	SK30515N-1
Fluorocarbon Seal	SK30515V-1

Order Bodies Separately
 See section BC

B08 — **2** — **6T**

08 size 2-Way Cavity Port Size

Code	Porting / Body Material
6T	SAE-6 / Steel (5000 PSI)

CV	Check Valves
SH	Shuttle Valves
LM	Load/Motor Controls
FC	Flow Controls
PC	Pressure Controls
LE	Logic Elements
DC	Directional Controls
SV	Solenoid Valves
PV	Proportional Valves
CE	Coils & Electronics
BC	Bodies & Cavities
TD	Technical Data

General Description

Cartridge Style Check Valve.
 For additional information see Technical Tips on pages CV2-CV3.

Features

- Spherical poppet for low leakage
- "D"-Ring eliminates back-up rings
- Dual sense paths for reduced ΔP
- All external parts zinc plated

Performance Curve

Pressure Drop vs. Flow (Through cartridge only)

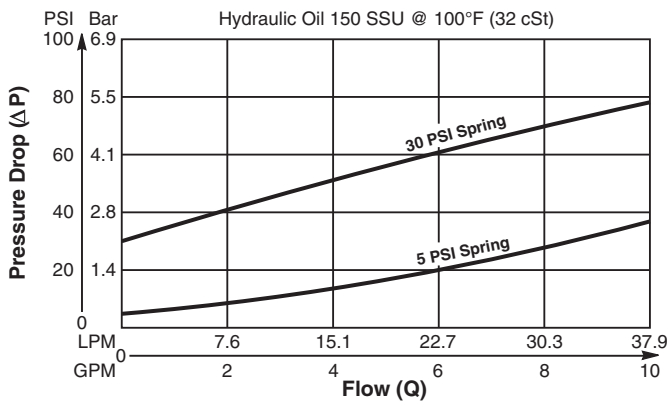

Specifications

Rated Flow	38 LPM (10 GPM)
Maximum Inlet Pressure	350 Bar (5000 PSI)
Leakage at 150 SSU (32 cSt)	2 drops/min. (0.13 cc/min) at 350 Bar (5000 PSI)
Cartridge Material	All parts steel. All operating parts hardened steel.
Operating Temp. Range/Seals	-37°C to +93°C ("D"-Ring) (-35°F to +200°F) -34°C to +121°C (Nitrile) (-30°F to +250°F) -26°C to +204°C (Fluorocarbon) (-15°F to +400°F)
Fluid Compatibility/Viscosity	Mineral-based or synthetic with lubricating properties at viscosities of 45 to 2000 SSU (6 to 420 cSt)
Filtration	ISO-4406 18/16/13, SAE Class 4
Approx. Weight	0.10 kg (0.2 lbs.)
Cavity	C08-2 (See BC Section for more details)

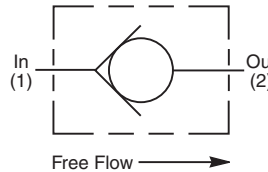
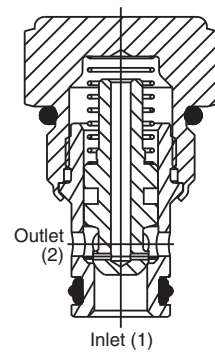

Dimensions Millimeters (Inches)

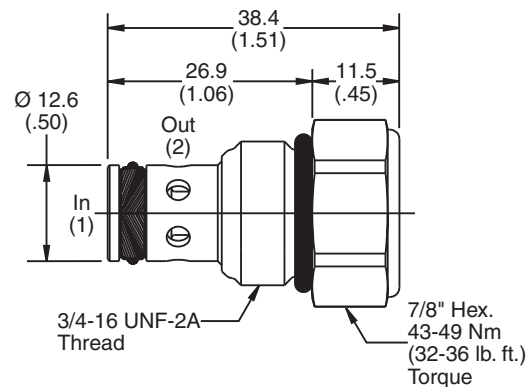

Ordering Information

CVH081P

08 Size Check Valve **Cracking Pressure**

Highlighted represents preferred options that offer the shortest lead times. Other options may be available, but at extended lead times.

Code	Cracking Pressure
Omit	0.3 Bar (5 PSI)
30	2.1 Bar (30 PSI)
65	4.5 Bar (65 PSI)
100	6.9 Bar (100 PSI)

Kit	Part Number
D-Ring Seal	SK08-2
Nitrile Seal	SK08-2
Fluorocarbon Seal	SK08-2V

Order Bodies Separately
 See section BC

B08 - **2** - **6T**

08 size 2-Way Cavity Port Size

Code	Seals
Omit	"D"-Ring

Code	Porting / Body Material
6T	SAE-6 / Steel (5000 PSI)

CV	Check Valves
SH	Shuttle Valves
LM	Load/Motor Controls
FC	Flow Controls
PC	Pressure Controls
LE	Logic Elements
DC	Directional Controls
SV	Solenoid Valves
PV	Proportional Valves
CE	Coils & Electronics
BC	Bodies & Cavities
TD	Technical Data

General Description

Cartridge Style Check Valve.
 For additional information see Technical Tips on pages CV2-CV3.

Features

- Spherical poppet for low leakage
- “D”-Ring eliminates back-up rings
- Dual sense paths for reduced ΔP
- All external parts zinc plated

Performance Curve

Pressure Drop vs. Flow (Through cartridge only)

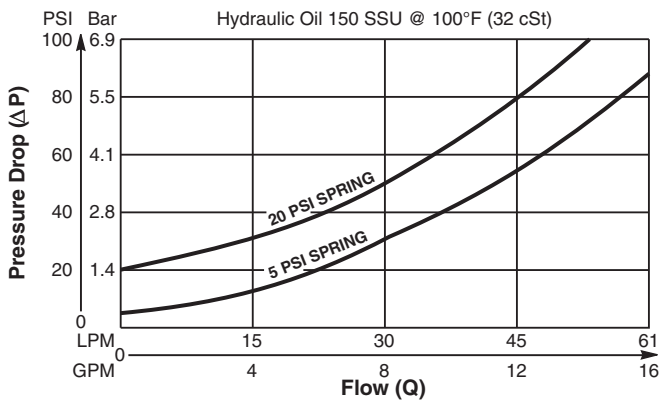

Specifications

Rated Flow	60 LPM (16 GPM)
Maximum Inlet Pressure	350 Bar (5000 PSI)
Leakage at 150 SSU (32 cSt)	2 drops/min. (0.13 cc/min) at 350 Bar (5000 PSI)
Cartridge Material	All parts steel. All operating parts hardened steel.
Operating Temp. Range/Seals	-37°C to +93°C ("D"-Ring) (-35°F to +200°F) -34°C to +121°C (Nitrile) (-30°F to +250°F) -26°C to +204°C (Fluorocarbon) (-15°F to +400°F)
Fluid Compatibility/Viscosity	Mineral-based or synthetic with lubricating properties at viscosities of 45 to 2000 SSU (6 to 420 cSt)
Filtration	ISO-4406 18/16/13, SAE Class 4
Approx. Weight	0.9 kg (2.0 lbs.)
Cavity	C10-2 (See BC Section for more details)

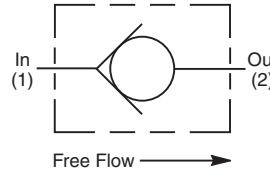
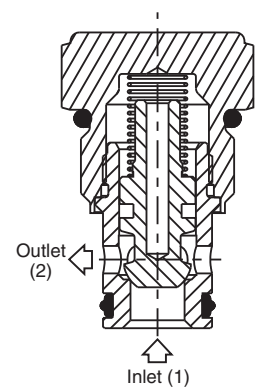

Dimensions Millimeters (Inches)

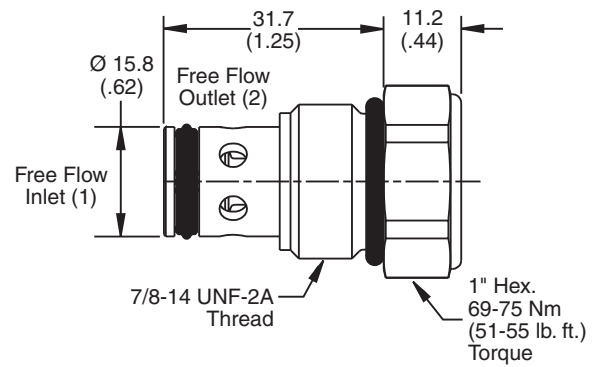

Ordering Information



Highlighted represents preferred options that offer the shortest lead times. Other options may be available, but at extended lead times.

Code	Cracking Pressure
Omit	0.3 Bar (5 PSI)
20	1.4 Bar (20 PSI)
50	3.5 Bar (50 PSI)
100	6.9 Bar (100 PSI)

Kit	Part Number
D-Ring Seal	SK10-2
Nitrile Seal	SK10-2
Fluorocarbon Seal	SK10-2V

Order Bodies Separately
 See section BC

Code	Seals
Omit	"D"-Ring



Code	Porting / Body Material
8T	SAE-8 / Steel (5000 PSI)

CV
 Check Valves

SH
 Shuttle Valves

LM
 Load/Motor Controls

FC
 Flow Controls

PC
 Pressure Controls

LE
 Logic Elements

DC
 Directional Controls

SV
 Solenoid Valves

PV
 Proportional Valves

CE
 Coils & Electronics

BC
 Bodies & Cavities

TD
 Technical Data

General Description

Ball Type Check Valve.
 For additional information see Technical Tips on pages CV2-CV3.

Features

- Low leakage - less than 3 drops/min.
- Ball type construction for cost effective design
- Single and dual pilot pistons available to create pilot to open check
- Range of cracking pressures available
- Good contamination tolerance
- All external parts zinc plated

Performance Curve

Pressure Drop vs. Flow (Through cartridge only)

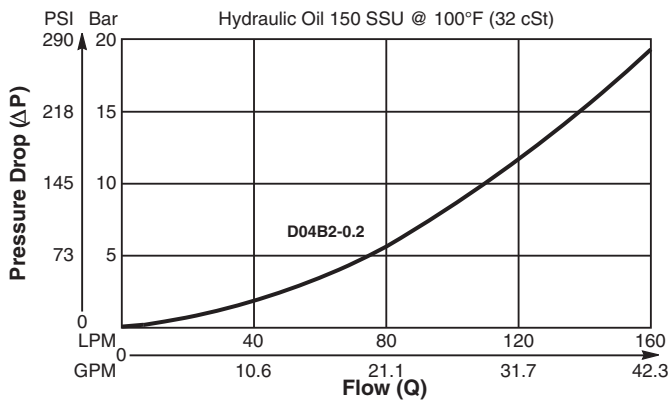

Specifications

Rated Flow	160 LPM (42 GPM)
Nominal Flow @ 7 Bar (100 PSI)	90 LPM (24 GPM)
Maximum Inlet Pressure	420 Bar (6000 PSI)
Leakage at 150 SSU (32 cSt)	3 drops/min.
Cartridge Material	Steel operating parts, hardened steel ball.
Operating Temp. Range/Seals	-34°C to +121°C (Nitrile, Buna-N) (-30°F to +250°F) -26°C to +204°C (Fluorocarbon) (-15°F to +400°F)
Fluid Compatibility/Viscosity	Mineral-based or synthetic with lubricating properties at viscosities of 45 to 2000 SSU (6 to 420 cSt)
Filtration	ISO-4406 18/16/13, SAE Class 4
Approx. Weight	0.08 kg (0.18 lbs.)
Cavity	C10-2 (See BC Section for more details)

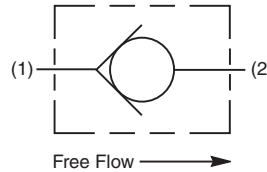
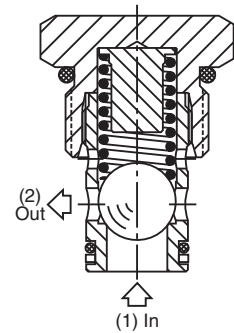

Dimensions Millimeters (Inches)

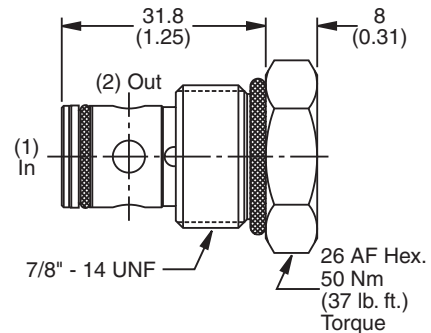

Ordering Information

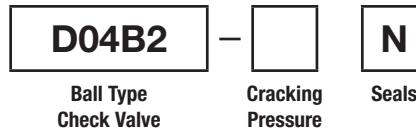

Highlighted represents preferred options that offer the shortest lead times. Other options may be available, but at extended lead times.

Code	Cracking Pressure
0.2	0.2 Bar (3 PSI) Std.
2.1	2.1 Bar (30 PSI)

Kit	Part Number
Nitrile Seal	SK30516N-1
Fluorocarbon Seal	SK30516V-1

Code	Seals
N	Nitrile

Order Bodies Separately
 See section BC



Code	Porting / Body Material
8T	SAE-8 / Steel (5000 PSI)

CV
Check Valves
SH
Shuttle Valves
LM
Load/Motor Controls
FC
Flow Controls
PC
Pressure Controls
LE
Logic Elements
DC
Directional Controls
SV
Solenoid Valves
PV
Proportional Valves
CE
Coils & Electronics
BC
Bodies & Cavities
TD
Technical Data

General Description

Cartridge Style Check Valve.
 For additional information see Technical Tips on pages CV2-CV3.

Features

- Hardened, precision ground parts for durability
- Fully guided poppet for smooth operation
- All external parts zinc plated

Performance Curve

Pressure Drop vs. Flow (Through cartridge only)

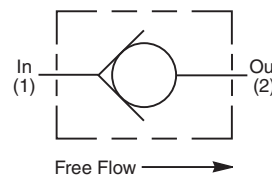
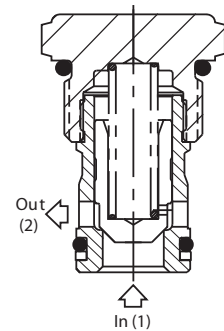
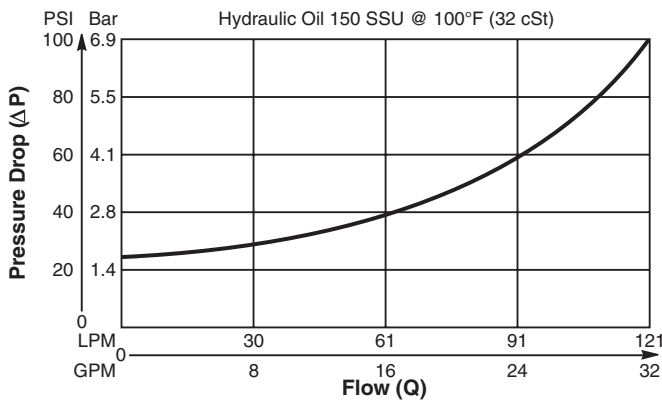

Dimensions Millimeters (Inches)

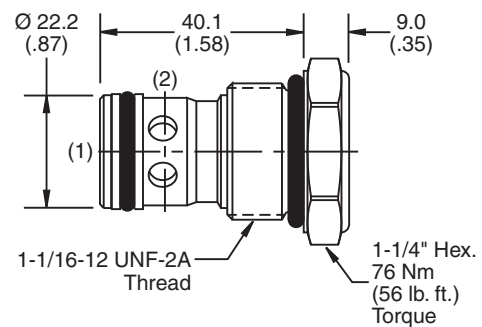

Specifications

Rated Flow	121 LPM (32 GPM)
Maximum Inlet Pressure	350 Bar (5000 PSI)
Leakage at 150 SSU (32 cSt)	5 drops/min. (0.33 cc/min) at 350 Bar (5000 PSI)
Cartridge Material	All parts steel. All operating parts hardened steel.
Operating Temp. Range/Seals	-34°C to +121°C (Nitrile) (-30°F to +250°F) -26°C to +204°C (Fluorocarbon) (-15°F to +400°F)
Fluid Compatibility/Viscosity	Mineral-based or synthetic with lubricating properties at viscosities of 45 to 2000 SSU (6 to 420 cSt)
Filtration	ISO-4406 18/16/13, SAE Class 4
Approx. Weight	0.14 kg (0.30 lbs.)
Cavity	C12-2 (See BC Section for more details)

Ordering Information

CVH121P

12 Size
 Check Valve

Highlighted represents preferred options that offer the shortest lead times. Other options may be available, but at extended lead times.

Code	Cracking Pressure
Omit	1.7 Bar (25 PSI)

Code	Seals
Omit	Nitrile

Kit	Part Number
Nitrile Seal	SK12-2
Fluorocarbon Seal	SK12-2V

Order Bodies Separately
 See section BC

B12	—	2	—	12T
12 size		2-Way Cavity		Port Size

Code	Porting / Body Material
12T	SAE-12 / Steel (5000 PSI)

CV	Check Valves
SH	Shuttle Valves
LM	Load/Motor Controls
FC	Flow Controls
PC	Pressure Controls
LE	Logic Elements
DC	Directional Controls
SV	Solenoid Valves
PV	Proportional Valves
CE	Coils & Electronics
BC	Bodies & Cavities
TD	Technical Data

General Description

Poppet Type Check Valve.
 For additional information see Technical Tips on pages CV2-CV3.

Features

- Extra low pressure drop capability for systems up to 250 Bar
- Poppet type construction for minimal leakage - less than 3 drops/min.
- Hardened poppet for maximum durability
- Good contamination tolerance
- All external parts zinc plated

Performance Curve

Pressure Drop vs. Flow (Through cartridge only)

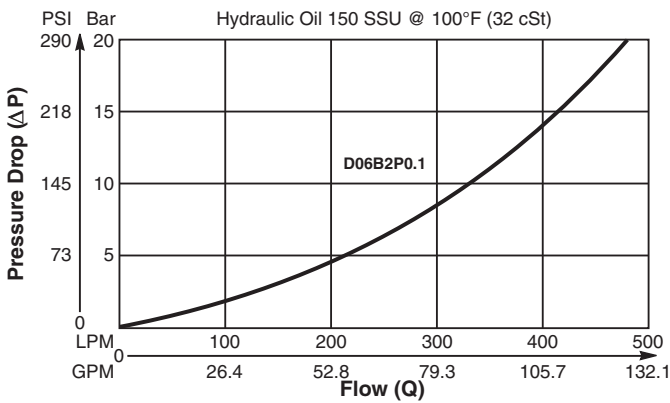

Specifications

Rated Flow	500 LPM (132 GPM)
Nominal Flow @ 7 Bar (100 PSI)	280 LPM (74 GPM)
Maximum Inlet Pressure	420 Bar (6000 PSI)
Leakage at 150 SSU (32 cSt)	Less than 3 drops/min.
Cartridge Material	Steel operating parts, hardened steel poppet.
Operating Temp. Range/Seals	-34°C to +121°C (Nitrile, Buna-N) (-30°F to +250°F) -26°C to +204°C (Fluorocarbon) (-15°F to +400°F)
Fluid Compatibility/Viscosity	Mineral-based or synthetic with lubricating properties at viscosities of 45 to 2000 SSU (6 to 420 cSt)
Filtration	ISO-4406 18/16/13, SAE Class 4
Approx. Weight	0.27 kg (0.60 lbs.)
Cavity	C16-2 (See BC Section for more details)

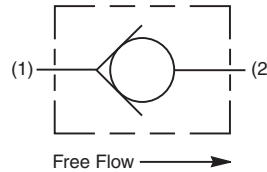
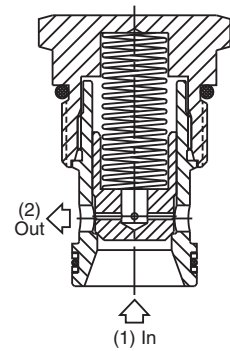
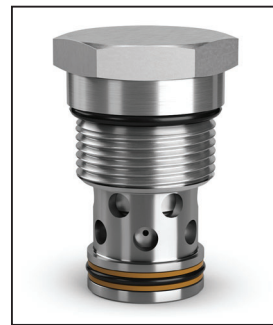

Dimensions Millimeters (Inches)

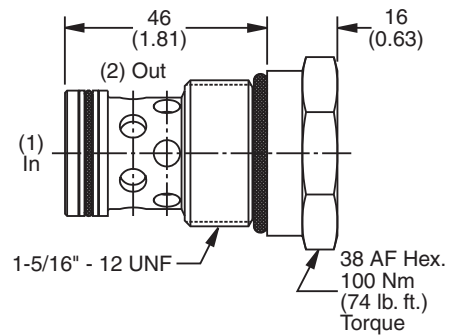

Ordering Information

D06B2P	0.1	N
16 Size Check Valve	Cracking Pressure	Seals

Highlighted represents preferred options that offer the shortest lead times. Other options may be available, but at extended lead times.

Code	Cracking Pressure
0.1	0.1 Bar (1.5 PSI) Std.

Code	Seals
N	Nitrile

Kit	Part Number
Nitrile Seal	SK30507N-1
Fluorocarbon Seal	SK30507V-1

Order Bodies Separately
 See section BC

B16	2	16T
16 size	2-Way Cavity	Port Size

Code	Porting / Body Material
16T	SAE-16 / Steel (5000 PSI)

CV	Check Valves
SH	Shuttle Valves
LM	Load/Motor Controls
FC	Flow Controls
PC	Pressure Controls
LE	Logic Elements
DC	Directional Controls
SV	Solenoid Valves
PV	Proportional Valves
CE	Coils & Electronics
BC	Bodies & Cavities
TD	Technical Data

General Description

Cartridge Style Check Valve.
 For additional information see Technical Tips on pages CV2-CV3.

Features

- Hardened, precision ground parts for durability
- Fully guided poppet for smooth operation
- All external parts zinc plated

Performance Curve

Pressure Drop vs. Flow (Through cartridge only)

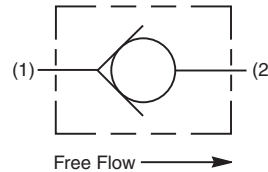
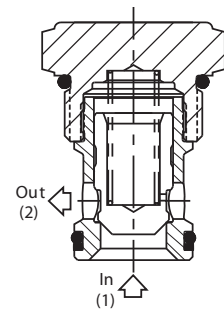
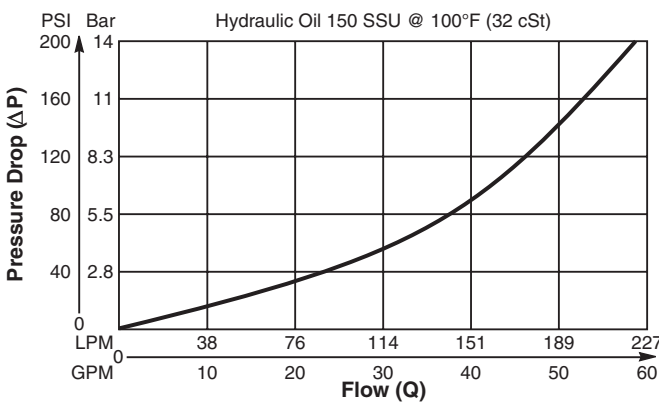

Dimensions Millimeters (Inches)

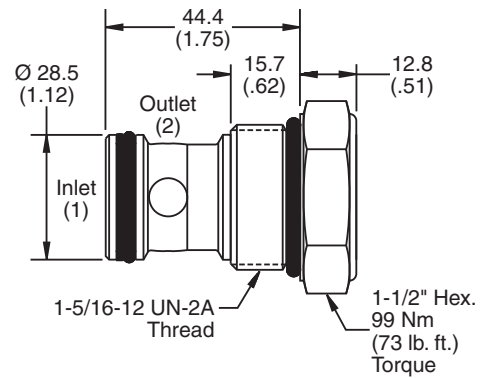

Specifications

Rated Flow	225 LPM (60 GPM)
Maximum Inlet Pressure	350 Bar (5000 PSI)
Leakage at 150 SSU (32 cSt)	5 drops/min. (0.33 cc/min) at 350 Bar (5000 PSI)
Cartridge Material	All parts steel. All operating parts hardened steel.
Operating Temp. Range/Seals	-34°C to +121°C (Nitrile) (-30°F to +250°F) -26°C to +204°C (Fluorocarbon) (-15°F to +400°F)
Fluid Compatibility/Viscosity	Mineral-based or synthetic with lubricating properties at viscosities of 45 to 2000 SSU (6 to 420 cSt)
Filtration	ISO-4406 18/16/13, SAE Class 4
Approx. Weight	0.27 kg (0.60 lbs.)
Cavity	C16-2 (See BC Section for more details)

Ordering Information

CVH161P	<input type="checkbox"/>
16 Size Check Valve	Cracking Pressure

Highlighted represents preferred options that offer the shortest lead times. Other options may be available, but at extended lead times.

Code	Cracking Pressure
Omit	0.3 Bar (5 PSI)
20	1.4 Bar (20 PSI)

Kit	Part Number
Nitrile Seal	SK16-2
Fluorocarbon Seal	SK16-2V

Code	Seals
Omit	Nitrile

Order Bodies Separately See section BC

B16 — **2** — **16T**

16 size 2-Way Cavity Port Size

Code	Porting / Body Material
16T	SAE-16 / Steel (5000 PSI)

CV	Check Valves
SH	Shuttle Valves
LM	Load/Motor Controls
FC	Flow Controls
PC	Pressure Controls
LE	Logic Elements
DC	Directional Controls
SV	Solenoid Valves
PV	Proportional Valves
CE	Coils & Electronics
BC	Bodies & Cavities
TD	Technical Data

General Description

Cartridge Style Check Valve.
 For additional information see Technical Tips on pages CV2-CV3.

Features

- Hardened, precision ground parts for durability
- Fully guided poppet for smooth operation
- All external parts zinc plated

Performance Curve

Pressure Drop vs. Flow (Through cartridge only)

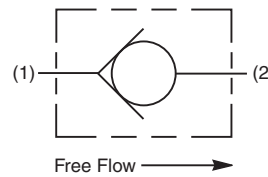
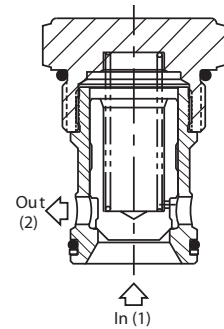
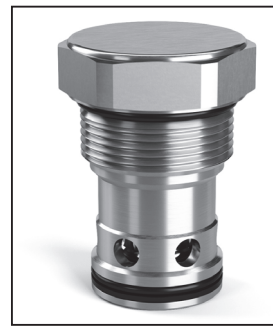
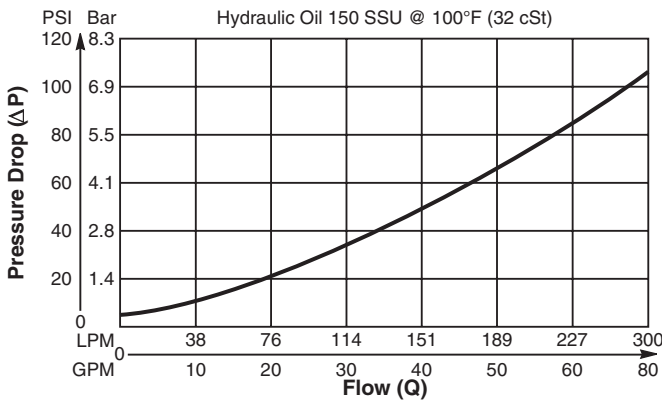

Dimensions Millimeters (Inches)

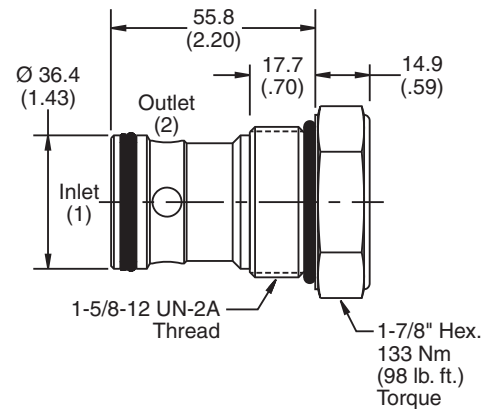

Specifications

Rated Flow	303 LPM (80 GPM)
Maximum Inlet Pressure	350 Bar (5000 PSI)
Leakage at 150 SSU (32 cSt)	5 drops/min. (0.33 cc/min) at 350 Bar (5000 PSI)
Cartridge Material	All parts steel. All operating parts hardened steel.
Operating Temp. Range/Seals	-34°C to +121°C (Nitrile) (-30°F to +250°F) -26°C to +204°C (Fluorocarbon) (-15°F to +400°F)
Fluid Compatibility/Viscosity	Mineral-based or synthetic with lubricating properties at viscosities of 45 to 2000 SSU (6 to 420 cSt)
Filtration	ISO-4406 18/16/13, SAE Class 4
Approx. Weight	0.27 kg (0.60 lbs.)
Cavity	C20-2 (See BC Section for more details)

Ordering Information

CVH201P

20 Size
 Check Valve

Highlighted represents preferred options that offer the shortest lead times. Other options may be available, but at extended lead times.

Code	Cracking Pressure
Omit	0.3 Bar (5 PSI)

Code	Seals
Omit	Nitrile

Kit	Part Number
Nitrile Seal	SK20-2
Fluorocarbon Seal	SK20-2V

Order Bodies Separately
 See section BC

B20	—	2	—	20T
20 size		2-Way Cavity		Port Size

Code	Porting / Body Material
20T	SAE-20 / Steel (5000 PSI)

General Description

Cartridge Style Pilot Operated Check Valve. For additional information see Technical Tips on pages CV2-CV3.

Features

- Hardened, precision ground parts for durability
- Internal pilot position simplifies manifold design
- All external parts zinc plated

Performance Curve

Pressure Drop vs. Flow (Through cartridge only)

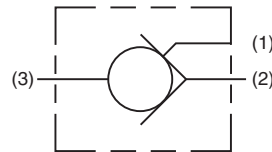
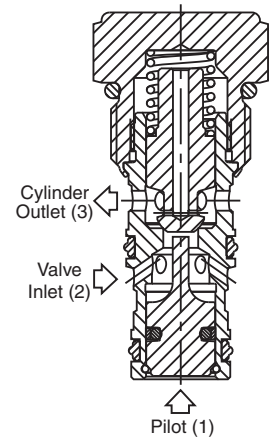
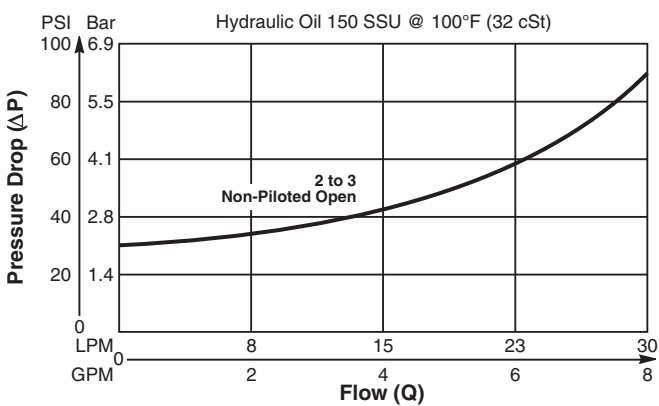

Dimensions Millimeters (Inches)

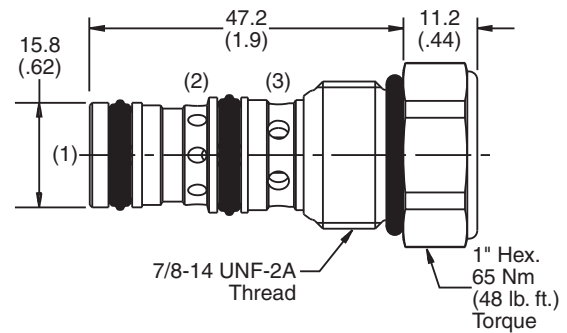

Specifications

Rated Flow	30 LPM (8 GPM)
Maximum Inlet Pressure	350 Bar (5000 PSI)
Leakage at 150 SSU (32 cSt)	2 drops/min. (0.13 cc/min) at 350 Bar (5000 PSI)
Pilot Ratio	4:1
Cartridge Material	All parts steel. All operating parts hardened steel.
Operating Temp. Range/Seals	-37°C to +93°C ("D"-Ring) (-35°F to +200°F) -34°C to +121°C (Nitrile) (-30°F to +250°F) -26°C to +204°C (Fluorocarbon) (-15°F to +400°F)
Fluid Compatibility/Viscosity	Mineral-based or synthetic with lubricating properties at viscosities of 45 to 2000 SSU (6 to 420 cSt)
Filtration	ISO-4406 18/16/13, SAE Class 4
Approx. Weight	0.9 kg (2.0 lbs.)
Cavity	C10-3 (See BC Section for more details)

Ordering Information

CPH104P

10 Size Check Valve

Highlighted represents preferred options that offer the shortest lead times. Other options may be available, but at extended lead times.

Code	Cracking Pressure
Omit	1.4 Bar (20 PSI)

Code	Seals
Omit	"D"-Ring

Kit	Part Number
D-Ring Seal	SK10-3
Nitrile Seal	SK10-3
Fluorocarbon Seal	SK10-3V

Order Bodies Separately See section BC

B10	—	3	—	8T
10 size		3-Way Cavity		Port Size

Code	Porting / Body Material
8T	SAE-8 / Steel (5000 PSI)



CV
Check Valves

SH
Shuttle Valves

LM
Load/Motor Controls

FC
Flow Controls

PC
Pressure Controls

LE
Logic Elements

DC
Directional Controls

SV
Solenoid Valves

PV
Proportional Valves

CE
Coils & Electronics

BC
Bodies & Cavities

TD
Technical Data

General Description

Cartridge Style Pilot Operated Check Valve.
 For additional information see Technical Tips on pages CV2-CV3.

Features

- Hardened, precision ground parts for durability
- Internal pilot position simplifies manifold design
- All external parts zinc plated

Performance Curve

Pressure Drop vs. Flow (Through cartridge only)

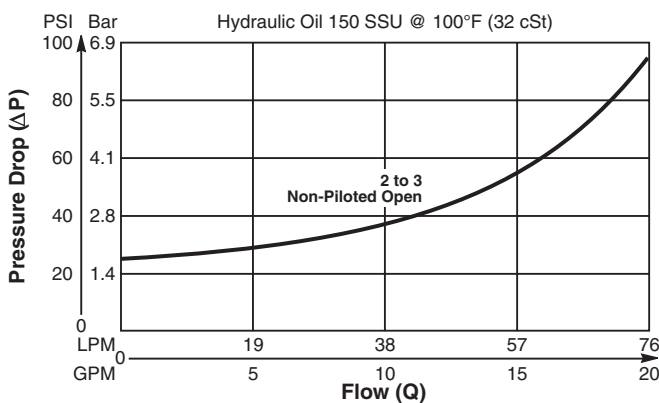

Specifications

Rated Flow	75 LPM (20 GPM)
Maximum Inlet Pressure	350 Bar (5000 PSI)
Leakage at 150 SSU (32 cSt)	5 drops/min. (0.33 cc/min) at 350 Bar (5000 PSI)
Pilot Ratio	3:1
Cartridge Material	All parts steel. All operating parts hardened steel.
Operating Temp. Range/Seals	-34°C to +121°C (Nitrile) (-30°F to +250°F) -26°C to +204°C (Fluorocarbon) (-15°F to +400°F)
Fluid Compatibility/Viscosity	Mineral-based or synthetic with lubricating properties at viscosities of 45 to 2000 SSU (6 to 420 cSt)
Filtration	ISO-4406 18/16/13, SAE Class 4
Approx. Weight	0.2 kg (0.44 lbs.)
Cavity	C12-3 (See BC Section for more details)

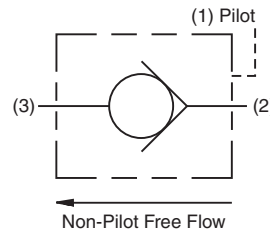
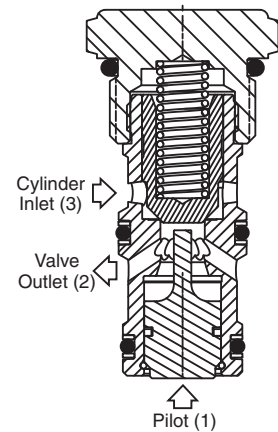

Dimensions Millimeters (Inches)

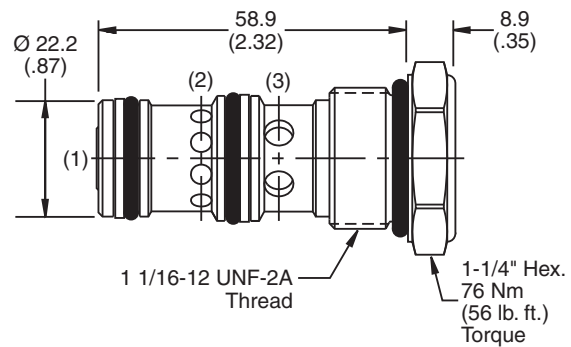

Ordering Information

CPH124P

12 Size
 P.O. Check Valve

Highlighted represents preferred options that offer the shortest lead times. Other options may be available, but at extended lead times.

Code	Cracking Pressure
Omit	1.7 Bar (25 PSI)

Code	Seals
Omit	Nitrile*

Kit	Part Number
Nitrile Seal	SK12-3
Fluorocarbon Seal	SK12-3V

* 2.5 size b/u rings

Order Bodies Separately
 See section BC



Code	Porting / Body Material
12T	SAE-12 / Steel (5000 PSI)

CV
 Check Valves

SH
 Shuttle Valves

LM
 Load/Motor Controls

FC
 Flow Controls

PC
 Pressure Controls

LE
 Logic Elements

DC
 Directional Controls

SV
 Solenoid Valves

PV
 Proportional Valves

CE
 Coils & Electronics

BC
 Bodies & Cavities

TD
 Technical Data

General Description

Pilot Piston Style Dual Pilot Operated Check Valve.
 For additional information see Technical Tips on pages CV2-CV3.

Features

- Spherical poppet for low leakage
- “D” -Ring eliminates back-up rings
- Optional sealed pilot piston

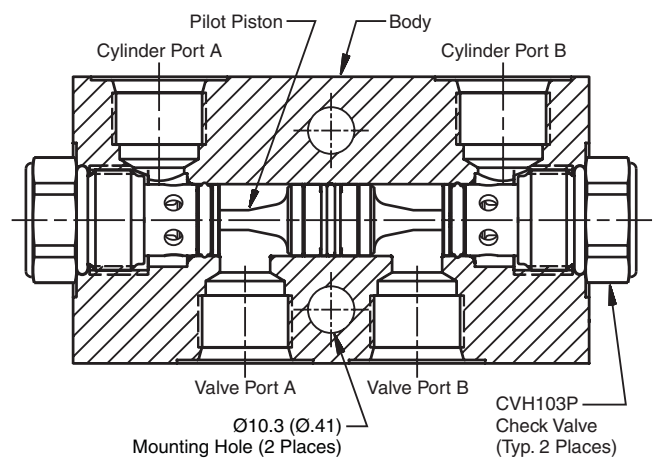

Specifications

Maximum Flow	60 LPM (16 GPM)
Maximum Inlet Pressure	350 Bar (5000 PSI) - CDPH103
Leakage Across Check 150 SSU (32 cSt)	2 drops/min. (0.13 cc/min.)
Leakage Across Pilot Piston (No Seals)	312 cc/min. 0.3 LPM (.08 GPM)
Pilot Ratio	4:1
Pilot Piston Part Numbers	No Seal - 717917 Nitrile Seal - 717917N Fluorocarbon Seal - 717917V
Cartridge Material	All parts steel. All operating parts hardened steel.
Body Material	Steel - CDPH103
Operating Temp. Range (Ambient)	-45°C to +132°C (“D”-Ring) (-50°F to +270°F) -34°C to +121°C (Nitrile) (-30°F to +250°F) -26°C to +204°C (Fluorocarbon) (-15°F to +400°F)
Fluid Compatibility/Viscosity	Mineral-based or synthetic with lubricating properties at viscosities of 45 to 2000 SSU (6 to 420 cSt)
Filtration	ISO-4406 18/16/13, SAE Class 4
Approx. Weight	1.59 kg (3.5 lbs.)

Performance Curve

Pressure Drop vs. Flow (Through cartridge only)

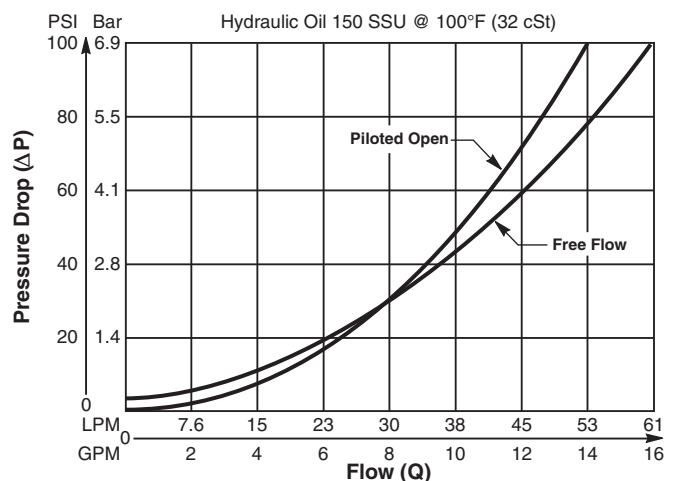

CV
Check Valves

SH
Shuttle Valves

LM
Load/Motor Controls

FC
Flow Controls

PC
Pressure Controls

LE
Logic Elements

DC
Directional Controls

SV
Solenoid Valves

PV
Proportional Valves

CE
Coils & Electronics

BC
Bodies & Cavities

TD
Technical Data

Dimensions Millimeters (Inches)

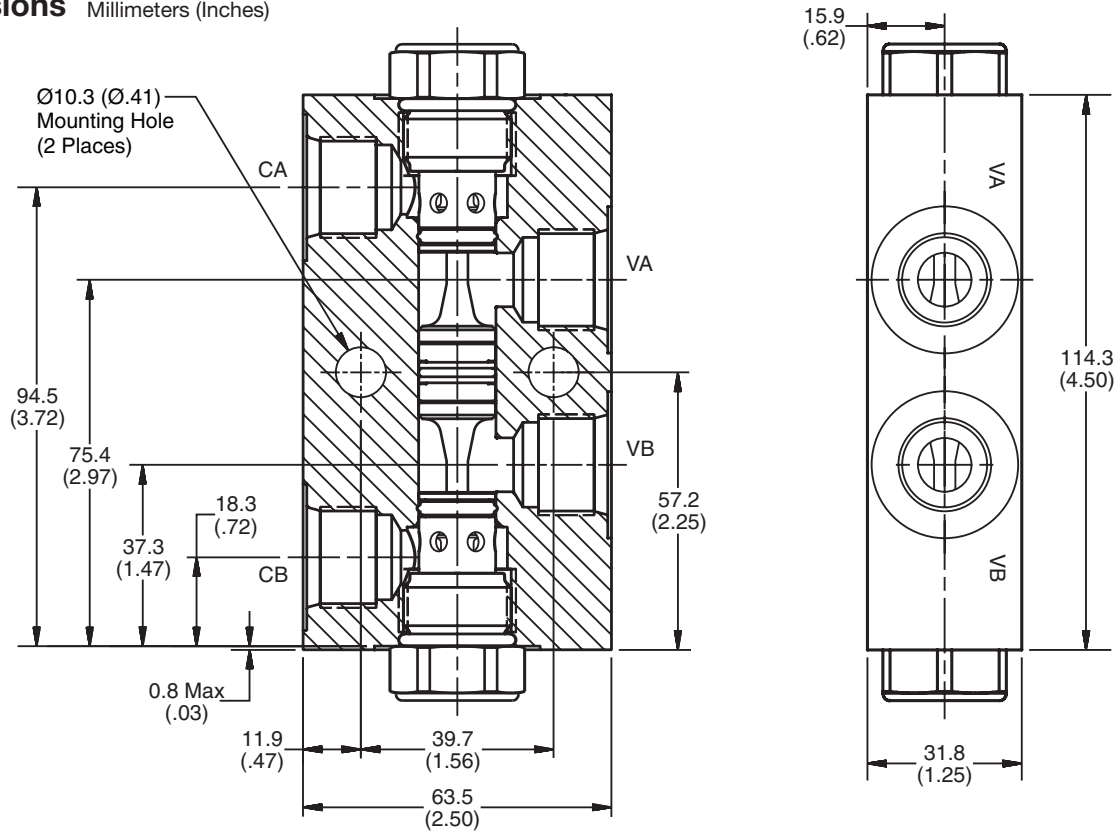

Ordering Information

CDP	H103			8T
10 Size Dual Pilot Piston P.O. Check Valve	Model Desc.	Piston Type	Cracking Pressure	Port Size

Highlighted represents preferred options that offer the shortest lead times. Other options may be available, but at extended lead times.

Code	Model Description
H103	5000 PSI Series

Code	Cracking Pressure
*Omit	0.3 Bar (5 PSI)
20	1.4 Bar (20 PSI)

**Not available with "A" option.*

Code	Seals
Omit	"D"-Ring

Code	Port Size / Body Material
8T	SAE-8 Steel (5000 PSI)

Code	Piston Type
P	Pilot Piston without seal
A	Pilot Piston with seal Note: Requires 1.4 Bar (20 PSI) crack minimum.

Kit	Part Number
Nitrile Seal	SK10-2
Fluorocarbon Seal	SK10-2V

CV	Check Valves
SH	Shuttle Valves
LM	Load/Motor Controls
FC	Flow Controls
PC	Pressure Controls
LE	Logic Elements
DC	Directional Controls
SV	Solenoid Valves
PV	Proportional Valves
CE	Coils & Electronics
BC	Bodies & Cavities
TD	Technical Data

General Description

Cartridge Style Dual Pilot Operated Check Valve. For additional information see Technical Tips on pages CV2-CV3.

Features

- Hardened, precision ground parts for durability
- Cost effective-replaces two cartridges
- Internal pilot position
- Common cavity
- All external parts zinc plated

Performance Curve

Pressure Drop vs. Flow (Through cartridge only)

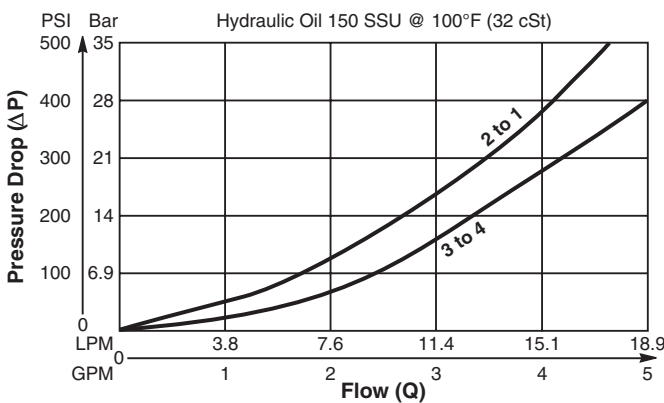

Specifications

Rated Flow	19 LPM (5 GPM)
Maximum Inlet Pressure	207 Bar (3000 PSI)
Leakage at 150 SSU (32 cSt)	5 drops/min. (0.33 cc/min) at 350 Bar (5000 PSI)
Pilot Ratio	3:1
Cartridge Material	All parts steel. All operating parts hardened steel.
Operating Temp. Range/Seals	-34°C to +121°C (Nitrile) (-30°F to +250°F) -26°C to +204°C (Fluorocarbon) (-15°F to +400°F)
Fluid Compatibility/Viscosity	Mineral-based or synthetic with lubricating properties at viscosities of 45 to 2000 SSU (6 to 420 cSt)
Filtration	ISO-4406 18/16/13, SAE Class 4
Approx. Weight	0.05 kg (0.11 lbs.)
Cavity	C08-4 (See BC Section for more details)

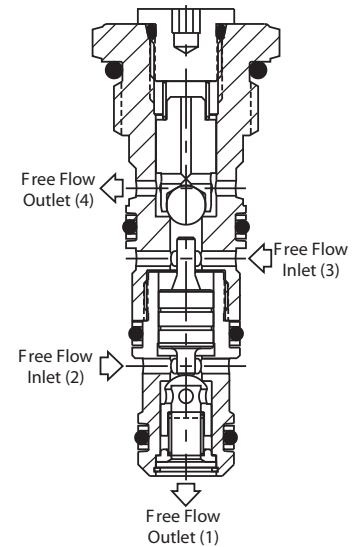
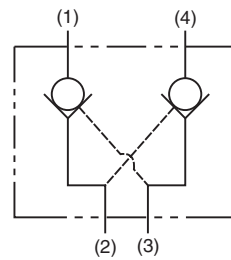

Dimensions Millimeters (Inches)

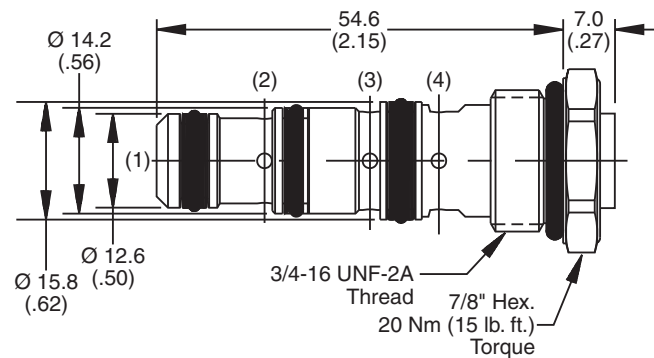

Ordering Information

CPD084P

08 Size
Dual P.O. Check Valve

Highlighted represents preferred options that offer the shortest lead times. Other options may be available, but at extended lead times.

Code	Seals
Omit	Nitrile

Kit	Part Number
Nitrile Seal	SK08-4
Fluorocarbon Seal	SK08-4V

Order Bodies Separately
 See section BC

B08 — **4** — **6T**

08 size 4-Way Cavity Port Size

Code	Porting / Body Material
6T	SAE-6 / Steel (5000 PSI)

CV
 Check Valves

SH
 Shuttle Valves

LM
 Load/Motor Controls

FC
 Flow Controls

PC
 Pressure Controls

LE
 Logic Elements

DC
 Directional Controls

SV
 Solenoid Valves

PV
 Proportional Valves

CE
 Coils & Electronics

BC
 Bodies & Cavities

TD
 Technical Data

Shuttle Valves

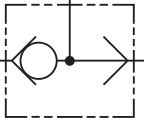
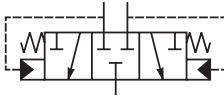
SERIES	CAVITY	DESCRIPTION	FLOW LPM/GPM	PRESSURE BAR/PSI	PAGE NO.	
Technical Tips.....					SH2	
	KSWA3	SW-3	Ball Insert Type	9.5/2.5	420/6000	SH3
	CSH041	C04-3	Cartridge Shuttle	3.8/1.0	345/5000	SH4
	CSH101B	C10-3	Cartridge Shuttle	38/10	207/3000	SH5
	K04C3	C10-4	Spool Type, Spring Centered, All Ports Closed	100/26	420/6000	SH6

CV
Check Valves

SH
Shuttle Valves

LM
Load/Motor Controls

FC
Flow Controls

PC
Pressure Controls

LE
Logic Elements

DC
Directional Controls

SV
Solenoid Valves

PV
Proportional Valves

CE
Coils & Electronics

BC
Bodies & Cavities

TD
Technical Data

INTRODUCTION:

Shuttle valves accept flow from two different sources and divert the highest pressure to a single outlet port. Shuttle valves are commonly used in Load Sensing circuits as well as Brake circuits. Parker offers a selection of ball and spool type Shuttle valves. There are both cartridge and insert type configurations available.

Ball Type - Cartridge Style

The valve consists of a steel ball that can seal against one of two adjacent seats, providing a path from the highest pressure signal to another function. When one inlet port is pressurized, the ball or poppet is forced against the opposite seat, blocking that inlet and providing a flow path to the outlet port.

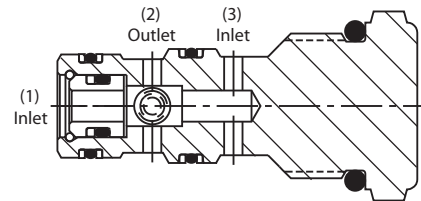
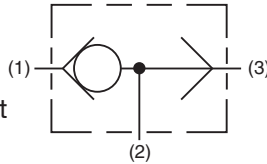

3 Way 2 Position Spool type shuttles are designed to direct flow in such a way as to allow higher pressure signals to open the lower pressure port and connect it to the common outlet port. These spring centered valves will shift when pressure at either end of the spool exceed the spring setting. These are typically used in transmission hot oil shuttle circuits.

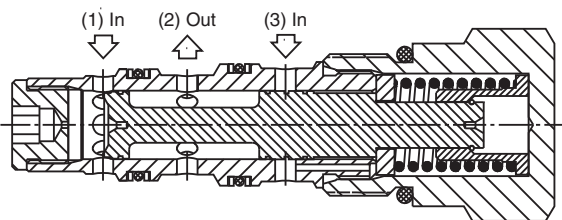
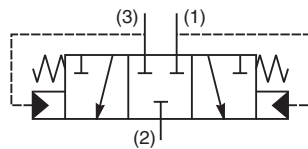

CV
Check Valves
SH
Shuttle Valves
LM
Load/Motor Controls
FC
Flow Controls
PC
Pressure Controls
LE
Logic Elements
DC
Directional Controls
SV
Solenoid Valves
PV
Proportional Valves
CE
Coils & Electronics
BC
Bodies & Cavities
TD
Technical Data

General Description

Ball Type, Two Position, Three Way Shuttle Valve.
 For additional information see Technical Tips on page SH2.

Features

- Compact, cost efficient design
- Ball type construction for maximum durability
- Minimal leakage - less than 10 drops/min.
- Contamination tolerant
- Hardened working parts for maximum durability
- All external parts zinc plated

Performance Curve

Pressure Drop vs. Flow (Through cartridge only)

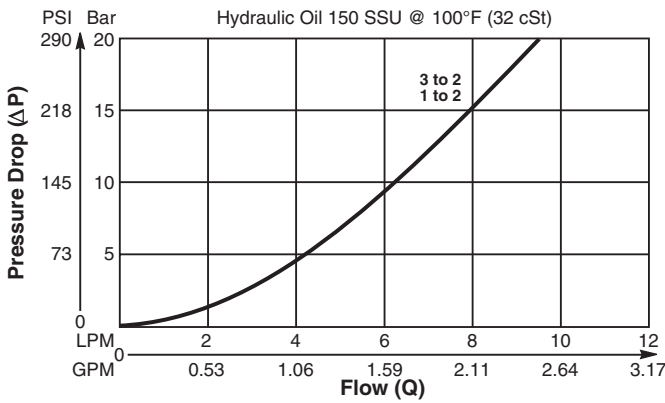

Specifications

Rated Flow	9.5 LPM (2.5 GPM)
Nominal Flow @ 7 Bar (100 PSI)	5 LPM (1.32 GPM)
Maximum Inlet Pressure	420 Bar (6000 PSI)
Cartridge Material	All parts steel. All operating parts, hardened steel.
Operating Temp. Range/Seals	-34°C to +121°C (Nitrile, Buna-N) (-30°F to +250°F) -26°C to +204°C (Fluorocarbon) (-15°F to +400°F)
Fluid Compatibility/Viscosity	Mineral-based or synthetic with lubricating properties at viscosities of 45 to 2000 SSU (6 to 420 cSt)
Filtration	ISO-4406 18/16/13, SAE Class 4
Approx. Weight	0.1 kg (0.02 lbs.)
Cavity	CAVSW-3 (See BC Section for more details)

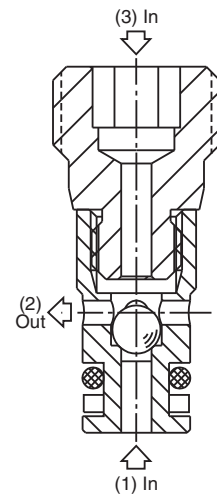
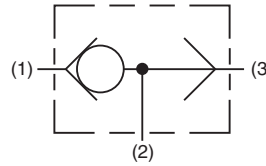

Dimensions Millimeters (Inches)

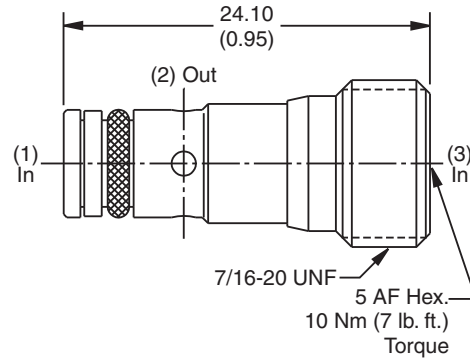

Application

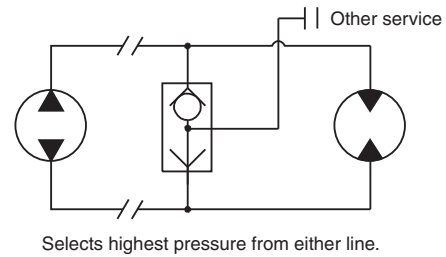

Ordering Information

KSWA3	N
Shuttle Valve	Seals

Highlighted represents preferred options that offer the shortest lead times. Other options may be available, but at extended lead times.

Code	Seals
N	Nitrile

Kit	Part Number
Nitrile Seal	SK30523N-1
Fluorocarbon Seal	SK30523V-1

CV	Check Valves
SH	Shuttle Valves
LM	Load/Motor Controls
FC	Flow Controls
PC	Pressure Controls
LE	Logic Elements
DC	Directional Controls
SV	Solenoid Valves
PV	Proportional Valves
CE	Coils & Electronics
BC	Bodies & Cavities
TD	Technical Data

General Description

Cartridge Style Shuttle Valve.
 For additional information see Technical Tips on page SH2.

Features

- Hardened working parts for maximum durability
- Rapid response to load direction changes
- All external parts zinc plated

Performance Curve

Pressure Drop vs. Flow (Through cartridge only)

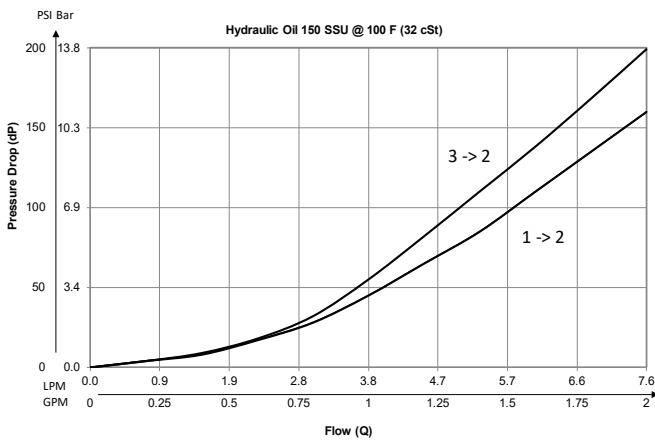

Specifications

Rated Flow	3.8 LPM (1 GPM)
Maximum Pressure Inlet	345 Bar (5000 PSI)
Leakage at 150 SSU (32cSt)	5 drops/min. (0.33 cc/min.)
Cartridge Material	All parts steel. All operating parts, hardened steel.
Operating Temp. Range/Seals	-34°C to +121°C (Nitrile, Buna-N) (-30°F to +250°F) -26°C to +204°C (Fluorocarbon) (-15°F to +400°F)
Fluid Compatibility/Viscosity	Mineral-based or synthetic with lubricating properties at viscosities of 45 to 2000 SSU (6 to 420 cSt)
Filtration	ISO-4406 18/16/13, SAE Class 4
Approx. Weight	0.2 kg (0.04 lbs.)
Cavity	C04-3 (See BC Section for more details)

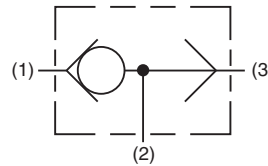
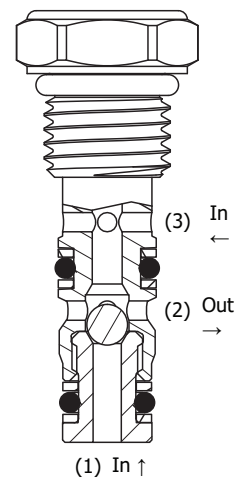

Dimensions Millimeters (Inches)

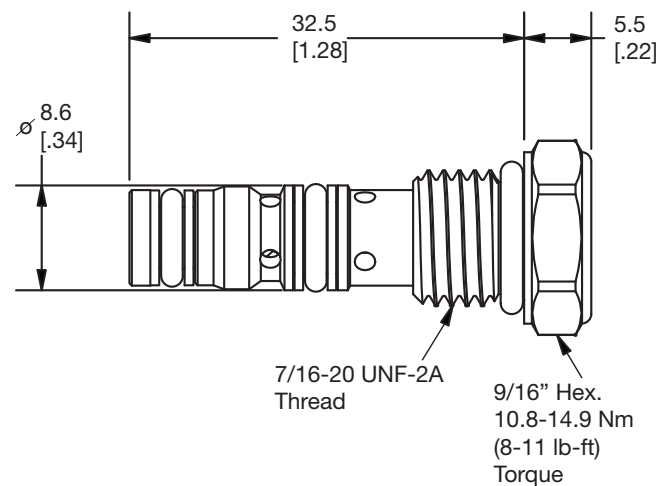

Ordering Information

CSH041

04 Size Shuttle Valve

Highlighted represents preferred options that offer the shortest lead times. Other options may be available, but at extended lead times.

Code	Seals
Omit	Nitrile

Order Bodies Separately
 See section BC

B04	-	3	-	4T
04 size		3-Way Cavity		Port Size

Kit	Part Number
Nitrile Seal	SK04-3
Fluorocarbon Seal	SK04-3V

Code	Porting / Body Material
4T	SAE-8 / Steel (5000 PSI)

CV	Check Valves
SH	Shuttle Valves
LM	Load/Motor Controls
FC	Flow Controls
PC	Pressure Controls
LE	Logic Elements
DC	Directional Controls
SV	Solenoid Valves
PV	Proportional Valves
CE	Coils & Electronics
BC	Bodies & Cavities
TD	Technical Data

General Description

Cartridge Style Shuttle Valve.
 For additional information see Technical Tips on page SH2.

Features

- Hardened precision ground parts for durability
- 5000 PSI rated
- All external parts zinc plated

Performance Curve

Pressure Drop vs. Flow (Through cartridge only)

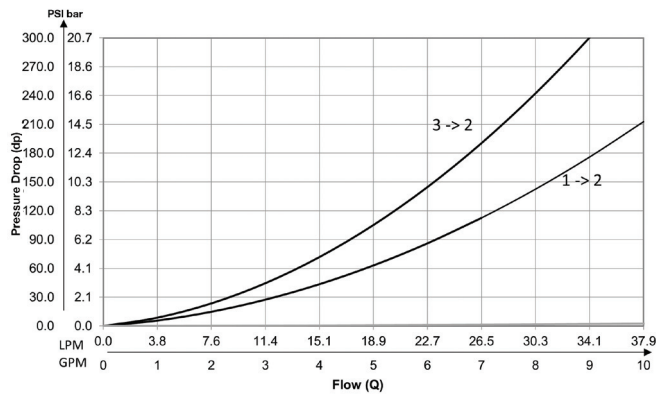

Specifications

Rated Flow	38 LPM (10 GPM)
Maximum Inlet Pressure	350 Bar (5000 PSI)
Leakage at 150 SSU (32cSt)	10 drops/min. (0.67 cc/min.) at 350 Bar (5000 PSI)
Cartridge Material	All parts steel. All operating parts, hardened steel.
Operating Temp. Range/Seals	-45°C to +93.3°C ("D"-Ring) (-50°F to +200°F) -34°C to +121°C (Nitrile) (-30°F to +250°F) -26°C to +204°C (Fluorocarbon) (-15°F to +400°F)
Fluid Compatibility/Viscosity	Mineral-based or synthetic with lubricating properties at viscosities of 45 to 2000 SSU (6 to 420 cSt)
Filtration	ISO-4406 18/16/13, SAE Class 4
Approx. Weight	0.38 kg (0.85 lbs.)
Cavity	C10-3 (See BC Section for more details)

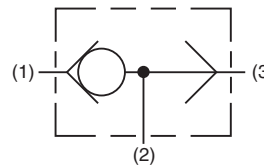
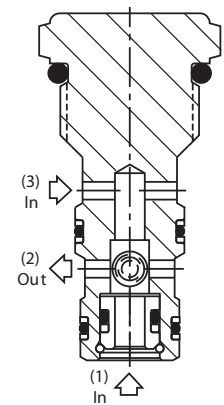
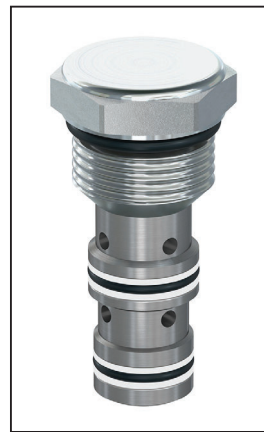

Dimensions Millimeters (Inches)

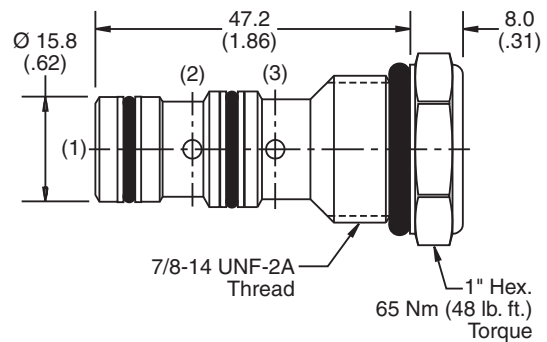

Ordering Information

CSH101B

10 Size Shuttle Valve

Highlighted represents preferred options that offer the shortest lead times. Other options may be available, but at extended lead times.

Code	Seals
Omit	'D' Ring

Order Bodies Separately
 See section BC

B10	3	8T
10 size	3-Way Cavity	Port Size

Kit	Part Number
D-Ring Seal	SK10-3
Nitrile Seal	SK10-3
Fluorocarbon Seal	SK10-3V

Code	Porting / Body Material
8T	SAE-8 / Steel (5000 PSI)

CV

Check Valves

SH

Shuttle Valves

LM

Load/Motor Controls

FC

Flow Controls

PC

Pressure Controls

LE

Logic Elements

DC

Directional Controls

SV

Solenoid Valves

PV

Proportional Valves

CE

Coils & Electronics

BC

Bodies & Cavities

TD

Technical Data

General Description

Two Position, Three Way, Spring Centered Shuttle Valve. For additional information see Technical Tips on page SH2.

Features

- High flow capacity
- Various switching pressures available
- Use as purge valve in transmission systems
- Hardened working parts for maximum durability
- All external parts zinc plated

Performance Curve

Pressure Drop vs. Flow (Through cartridge only)

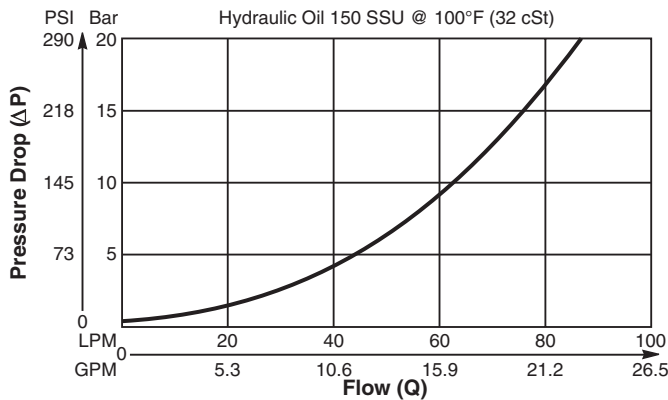

Application

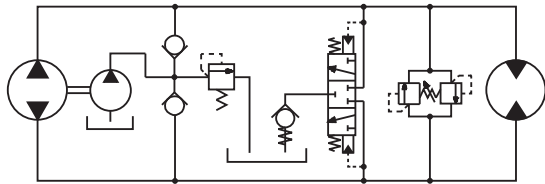

Purge valve in transmission circuit

Specifications

Rated Flow	100 LPM (26 GPM)
Nominal Flow @ 7 Bar (100 PSI)	55 LPM (15 GPM)
Maximum Inlet Pressure	420 Bar (6000 PSI)
Cartridge Material	All parts steel. All operating parts, hardened steel.
Operating Temp. Range/Seals	-34°C to +121°C (Nitrile, Buna-N) (-30°F to +250°F) -26°C to +204°C (Fluorocarbon) (-15°F to +400°F)
Fluid Compatibility/Viscosity	Mineral-based or synthetic with lubricating properties at viscosities of 45 to 2000 SSU (6 to 420 cSt)
Filtration	ISO-4406 18/16/13, SAE Class 4
Approx. Weight	0.17 kg (0.37 lbs.)
Cavity	C10-4 (See BC Section for more details)

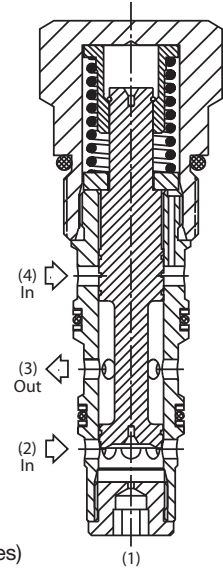
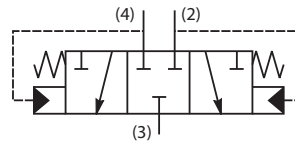

Dimensions Millimeters (Inches)

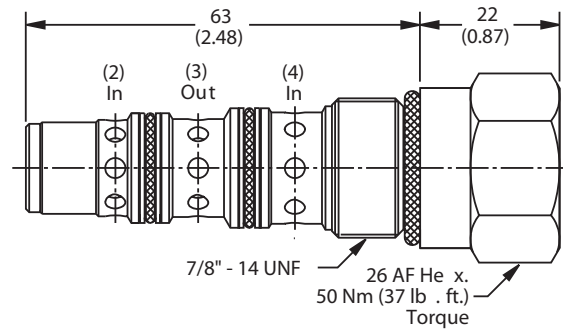

Ordering Information

K04C3	10.0	N
Shuttle Valve	Switching Pressure	Seals

Highlighted represents preferred options that offer the shortest lead times. Other options may be available, but at extended lead times.

Code	Switching Pressure
10.0	10.0 Bar (145 PSI)

Note: Port 1 on the Line Body must be plugged

Code	Seals
N	Nitrile

Order Bodies Separately
 See section BC

Kit	Part Number
Nitrile Seal	SK30504N-1
Fluorocarbon Seal	SK30504V-1

B10	4	8T
10 size	4-Way Cavity	Port Size

Code	Porting / Body Material
8T	SAE-8 / Steel (5000 PSI)

CV	Check Valves
SH	Shuttle Valves
LM	Load/Motor Controls
FC	Flow Controls
PC	Pressure Controls
LE	Logic Elements
DC	Directional Controls
SV	Solenoid Valves
PV	Proportional Valves
CE	Coils & Electronics
BC	Bodies & Cavities
TD	Technical Data

SERIES	CAVITY	DESCRIPTION	FLOW LPM/GPM	PRESSURE BAR/PSI	PAGE NO.
Technical Tips.....					LM2-LM5
STANDARD PILOT ASSISTED					
E2*1 (NEW)	CAVT11A	load Control Cartridge Valve	60/16	350/5000	LM6-LM7
E2*1R (NEW)	CAVT11A	load Control Cartridge Valve	60/16	350/5000	LM8-LM9
E2*1S (NEW)	CAVT11A	load Control Cartridge Valve	60/16	350/5000	LM10-LM11
CB101	C10-3	load Control Cartridge Valve	45/12	380/5500	LM12-LM13
MHC-010-S***	CDD-1010	Load Control Cartridge Valve	37/10	350/5000	LM14-LM15
E2*020	53-1	Load Control Cartridge Valve	20/5.3	420/6000	LM16-LM17
E2*040	68-1	Load Control Cartridge Valve	60/16	350/5000	LM18-LM19
E2*060	3C	Load Control Cartridge Valve	120/32	350/5000	LM20-LM21
E2*125	3M	Load Control Cartridge Valve	200/53	350/5000	LM22-LM23
E2*300	3K Flange	Load Control Cartridge Valve	350/92	350/5000	LM24-LM25
INDEPENDENT OF BACK-PRESSURE, VENTED TO ATMOSPHERE					
E6B020	53-1	Load Control Cartridge Valve, 4.5:1 Ratio	20/5.3	350/5000	LM26-LM27
E6K020	53-1	Load Control Cartridge Valve, 15:1 Ratio	20/5.3	420/6000	LM28-LM29
E6B040	68-1	Load Control Cartridge Valve, 3:1 Ratio	60/16	350/5000	LM30-LM31
E6B060*409	3C	Load Control Cartridge Valve, 3:1 Ratio	180/48	350/5000	LM32-LM33

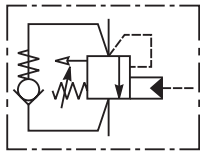
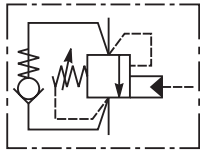

CV
Check Valves

SH
Shuttle Valves

LM
Load/Motor Controls

FC
Flow Controls

PC
Pressure Controls

LE
Logic Elements

DC
Directional Controls

SV
Solenoid Valves

PV
Proportional Valves

CE
Coils & Electronics

BC
Bodies & Cavities

TD
Technical Data

Introduction

Counterbalance valves are one of the most misunderstood products in the hydraulic industry. Many people tend to complicate the task of selecting a counterbalance valve and as such avoid opportunities. The goal of this Technical Tips Section is to hopefully eliminate some of this confusion and help you chose the correct valve for your application. It is only a guide! It is not meant to be your only method of input, nor is it meant to replace good hydraulic common sense and reasoning.

Application

DO I NEED A COUNTERBALANCE VALVE?

A counterbalance is generally used for one or more of the following purposes:

Control an Overrunning Load – It restricts the flow from an actuator, thus forcing the load to be pushed through the restriction and providing control of the potential runaway load. This also helps in the prevention of cavitation.

Control in Critical Metering Applications – The outward restriction also helps to gain control of systems with varying loads and speeds.

Holding a Load – Much like a pilot operated check valve, a load is held in one direction until the appropriate pilot pressure is available unseat the check and pass fluid.

Help Protect Against Hose Failures – Since the fluid must be pushed through a restriction, hose failures result in a controlled movement of the actuator and not a runaway load.

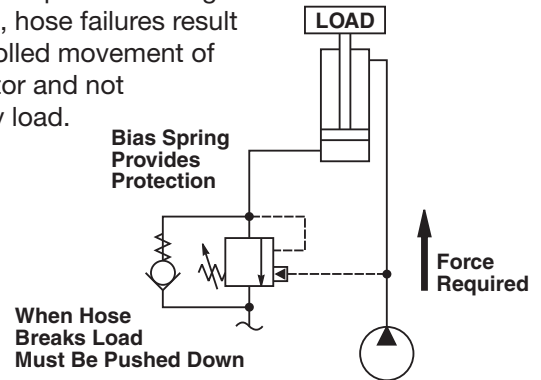

NOTE: Counterbalance Valves are only needed if the application calls for varying loads or varying speeds. If the load and speed are fixed, flow control valves and pilot operated check valves may be substituted at generally a lower cost.

Operation

An understanding of the general operation of a counterbalance valve is required before proceeding further into valve selection.

The counterbalance valve is a pressure control device and functions as follows: Pressure is developed at the Work Port of the holding valve when the actuator is pressurized. This pressure acts on the differential area, and the force generated is counteracted by the bias spring. When there is sufficient pressure present to overcome the spring setting, the poppet begins to shift, allowing fluid to pass through the valve port to tank via the control valve.

To assist in the shifting of the poppet, an external pressure source (generally the opposite side of the actuator) is connected to the pilot port of the counterbalance valve. This pressure is applied to the pilot area and assists the differential area in opening the valve. The pilot assist reduces load pressure required to open the valve, and allows for a reduction in the horsepower required to move the load. If the load attempts to “run away” (move faster than the pump can supply flow), the pilot signal will diminish and the piston will begin to close restricting flow to tank and thus controlling the load. The counterbalance piston will maintain a position that maintains a positive pilot signal and will control the descent of the load.

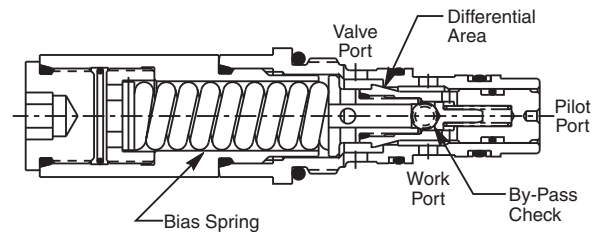

An added feature of the counterbalance valve is its built-in thermal relief characteristic. A temperature rise can cause thermal expansion of the hydraulic fluid trapped between the actuator and the counterbalance valve’s poppet. As the pressure increases and reaches the bias spring setting, the poppet unseats and a few drops of oil are allowed to escape through the valve port of the counterbalance valve. This relieves the thermal expansion of oil, allowing the counterbalance valve to continue holding the load in the same position.

When the flow is reversed to the actuator, then pressure unseats the built-in bypass check portion of the counterbalance valve allowing flow to pass from the valve port to the work port. When no pressure is applied to either port of the counterbalance valve, the load is held in place.

CV
Check Valves
SH
Shuttle Valves
LM
Load/Motor Controls
FC
Flow Controls
PC
Pressure Controls
LE
Logic Elements
DC
Directional Controls
SV
Solenoid Valves
PV
Proportional Valves
CE
Coils & Electronics
BC
Bodies & Cavities
TD
Technical Data

Technical Tips

Valve Series

Parker offers the four series of products outlined below:

MHC – The MHC series is a threaded cartridge style counterbalance valve. This series is ideal for incorporating into an integrated manifold or for installation directly into the port of the actuator. There are various flow rates and pilot ratios available for the MHC Series.

CB101 – The CB101 is also a threaded cartridge style counterbalance valve. It also is ideal for incorporating into an integrated manifold or for installation directly into the port of the actuator. The CB101 has an industry common cavity (C10-3) and is available in three pilot ratios.

E2 Series – The E2 Series valves are threaded cartridge style counterbalance valves. They are available in standard and Vented configurations. In the Vented configurations, the valves maintain their settings regardless of backpressure. There are various flow rates and pilot ratios available.

Load and Motor Control Valves



Selecting Options

Below is a brief description of the options available on the ordering information pages and a brief explanation of when each would be used.

Flow Selection – Generally the counterbalance valve is sized according to the actual flow the valve will see and not the system flow. Note that the ordering information callout is the nominal flow rate and not the maximum. In other words, refer to the pressure drop curves when sizing the valves. For example: A MHC-010 can flow 25 GPM, but is rated as a 10 GPM valve. It is possible to oversize a counterbalance valve! If the counterbalance is oversized, the annulus between the poppet and the seat is too large, thus the poppet opens too far causing instability. Remember you are gaining control by causing a restriction. If you oversize the counterbalance valve, the restriction is reduced and so is the control.

Vented versus Non-Vented – With a standard counterbalance valve, the bias spring is internally vented to tank. This means any pressure on the tank line is sensed in the bias spring chamber and additive to the setting. Thus, the pressure at the work port now must be greater than the bias spring plus the tank

pressure before the counterbalance poppet will shift allowing flow.

A vented style counterbalance valve relieves the bias spring chamber to atmosphere. Thus, the spring chamber is in no way related to the tank chamber of the counterbalance valve. So, if the pressure on the tank line is high, or if the pressure setting is critical, then a vented style counterbalance valve would be required.

Parker's counterbalance valves are externally vented. This means no extra porting or manifold costs are incurred when a vented counterbalance is needed.

MHC-010-S*S* Non-Vented Counterbalance Adjustable

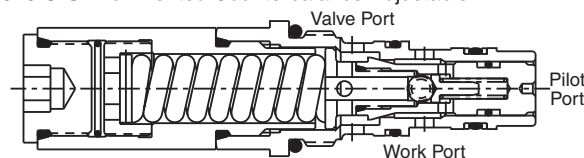

MHC-010-V*S* Vented Counterbalance Adjustable

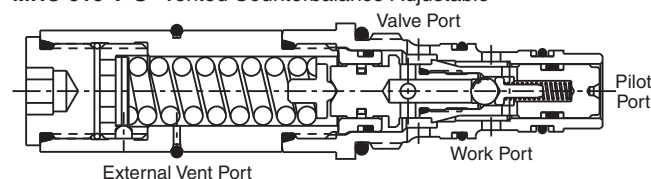

CV

Check Valves

SH

Shuttle Valves

LM

Load/Motor Controls

FC

Flow Controls

PC

Pressure Controls

LE

Logic Elements

DC

Directional Controls

SV

Solenoid Valves

PV

Proportional Valves

CE

Coils & Electronics

BC

Bodies & Cavities

TD

Technical Data

Technical Tips

Selection Options (Continued)

Pilot Ratio – The pilot ratio is the ratio of the pilot area versus the differential area poppet. Thus, the higher the pilot ratio, the less pressure that is needed to assist the load pressure in unseating the poppet. This means there is less restriction to the overrunning load, resulting in less horsepower required and more control of the load. So higher pilot ratio equates to less restriction to the overrunning load, less control and less horsepower required. Lower ratio equates to more restriction to the overrunning load, more control and more

horse-power required. The pilot ratio decision is one of Horsepower versus Control. For reference the most popular ratio is 3:1.

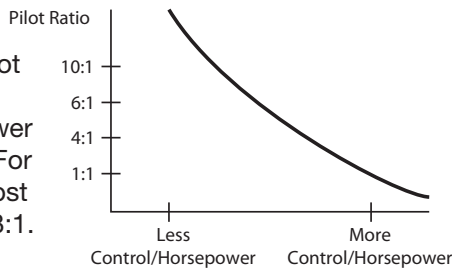

Sample Ratios:	
10:1	Primary function is motor control and hose break protection Loads moving at fast speeds and positioning is not critical
7.5:1, 6:1 and 5:1	Most popular starting ratio
4:1 and 3:1	Positioning is critical such as a pick and place application Greater stability
1:1	Motor control application

ADJUSTMENT TYPE

Parker offers counterbalance valves with adjustable and non-adjustable pressure settings. The non-adjustable or shimmed version is recommended for most applications as it prevents tampering or improper adjustment by uneducated end users.

SELECTING SETTINGS

There are three basic settings to consider before finalizing a counterbalance valve for your application.

Holding Setting – The holding setting is sometimes referred to as the counterbalance setting. It is the maximum load setting you expect the counterbalance to hold. Note that the counterbalance valve should be set for the absolute maximum hold pressure required. Also note that counterbalance valves are restrictive type devices and as such are not ideal for low pressure applications, such as those below 750 psi. The holding setting is the setting you choose when selecting a counterbalance valve.

Load and Motor Control Valves

Thermal Setting – Counterbalance valves have a built-in thermal relief valve that compensates for the expansion of oil, due to temperature, by bleeding off excess pressure. In other words, the thermal setting is the pressure that the counterbalance will unload at if no pressure is present at the pilot port. Obviously, this setting should be above the holding setting. The Parker **MHC** counterbalance valves are automatically set 1000 psi above the holding setting of the valve. **You do not specify this setting, only the holding setting.**

For the **CB101** Series, you do specify the Thermal/Crack setting in the model code. The holding setting (maximum load induced pressure) is 70% of that specified setting. Example: Hold at 3000 psi, crack at 4285 psi. For the **E2** Series, you specify the Thermal/Crack setting in the model code. The crack setting (maximum load induced pressure) should be 1.3 times the hold. Example: Hold at 210 Bar, crack at 273 Bar.

Pilot Area – The pilot pressure required to lower the cylinder when fully loaded and unloaded can also be determined before applying the valve. The pilot pressure can be determined by the below equation:

$$P_p = (T_s - L) / R_p$$

- P_p = Pilot Pressure
- T_s = Thermal Setting
- L = Induced Load
- R_p = Pilot Ratio

Example:

The maximum load is 3000 psi. A 6:1 Pilot Ratio was chosen and the thermal relief setting is the standard 1000 psi over load setting. What is the pilot pressure required to retract the cylinder if it is fully loaded? What pilot pressure is required to retract the cylinder if there is no load?

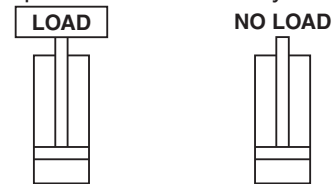

FULLY LOADED:

$$P_p = (4000 \text{ psi} - 3000 \text{ psi}) / 6$$

$$P_p = 1000 \text{ psi} / 6$$

$$P_p = 167 \text{ psi}$$

Thus, any time the pilot line sees at least 167 psi, the cylinder could lower the load.

UNLOADED:

$$P_p = (4000 \text{ psi} - 0 \text{ psi}) / 6$$

$$P_p = 4000 \text{ psi} / 6$$

$$P_p = 667 \text{ psi}$$

Thus, at least 667 psi will be needed to lower the cylinder when it is unloaded.

CV
Check Valves

SH
Shuttle Valves

LM
Load/Motor Controls

FC
Flow Controls

PC
Pressure Controls

LE
Logic Elements

DC
Directional Controls

SV
Solenoid Valves

PV
Proportional Valves

CE
Coils & Electronics

BC
Bodies & Cavities

TD
Technical Data

Technical Tips

Motor Controls

Counterbalance valves are used in motor circuits to stop overrunning loads and prevent cavitation. Since hydraulic motors leak internally, the counterbalance valve by itself cannot be used to hold the load. So, a mechanical brake is used to hold the load on the motor in place, as shown below. Some typical applications include winches, swing drives, conveyor control and traction drives. For applications in closed loop motor circuits, vented spring cavities are required.

Operation

Free flow to the motor is allowed through the internal check valve. In the controlled flow direction, the oil passes across a metering poppet. The position of the metering poppet is determined by an external pilot signal from the other side of the motor. In an open loop motor circuit, this pilot signal will be a 1:1 ratio. The reason an equal ratio pilot signal is utilized is to provide positive control as well as to release mechanical brakes (when used in a braking circuit). In applications where the motor will see overrunning loads in both directions (such as a traction drive circuit), a dual MMB or two single MMB valves must be used.

Brake Applications

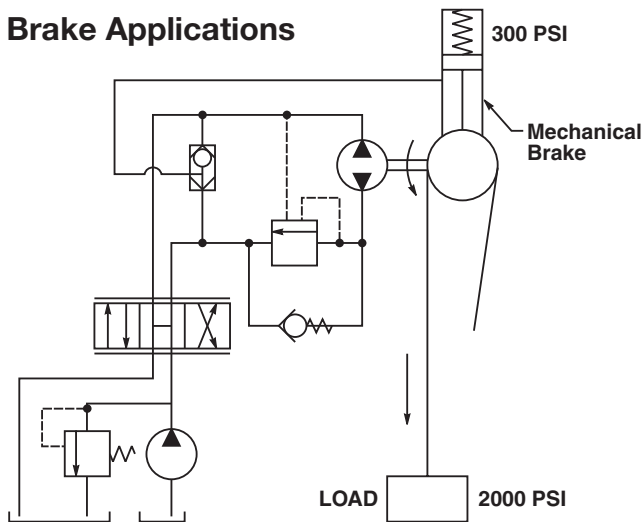

When the directional control valve is shifted, hydraulic pressure (usually 300 psi) releases the mechanical brake and allows the load to be moved. The counterbalance valve needs to provide adequate back pressure to open the brake, then immediately counterbalance the load. Ideally, the brake will be disengaged before the motor begins to rotate. If this sequence is not achieved, the motor will try to rotate against the applied brake reducing the life of the brake. This would be the equivalent of trying to drive with your emergency brake applied. Remember that hydraulic motors are equal area devices. So, in an effort to avoid the

Load and Motor Control Valves

movement of the motor prior to the release of the brake, an equal area ratio counterbalance is used. To demonstrate let's look again at the above example with a 10:1 Ratio Counterbalance valve installed and a maximum thermal setting of 3000 psi.

10:1 Example

NO LOAD

$$P_p = (T_s - L) / R_p$$

$$P_p = (3000 \text{ psi} - 0 \text{ psi}) / 10$$

$$P_p = 3000 \text{ psi} / 10$$

$$P_p = 300 \text{ psi}$$

2000 PSI LOAD

$$P_p = (T_s - L) / R_p$$

$$P_p = (3000 \text{ psi} - 2000 \text{ psi}) / 10$$

$$P_p = 1000 \text{ psi} / 10$$

$$P_p = 100 \text{ psi}$$

Thus, when there is no load on the motor, the counterbalance opens at 300 psi, or just as the brake is being released. When there is a 2000 psi load on the motor, the counterbalance will start to open with a pilot pressure of 100 psi. The brake requires 300 psi, so the motor can start to rotate before the brake is released, causing wear on the brake. To offset this problem, you could increase the maximum thermal setting to 5000 psi, but this is very inefficient.

1:1 (Equal Area) Example

Equal area counterbalance valves are used primarily in brake applications to avoid the wear problem described above. With an Equal Area counterbalance valve, there is no thermal relief valve, and there is no differential area to work on. In other words, the counterbalance valve only opens when the pilot pressure is greater than the valve setting. The applied load has nothing to do with the pilot pressure required. Thus you will want to choose a pressure setting for the equal area counterbalance valve that is just slightly above the brake release pressure (usually 350 psi).

In our example, the valve would be set at 350 psi. This would allow the brake to release before the counterbalance allows the load to move. Since the equal counterbalance valve always opens at 350 psi pilot pressure and is not dependent on the load, it is the best valve for brake applications.

Large Pressure Spike Application – Keep in mind that equal area counterbalance valves do not have a built-in thermal relief valve. As such, if there are large pressure spikes caused by the stopping of heavy loads, then a ratioed counterbalance, such as a 10:1 should be used. In most cases these are non-brake type applications.

CV	Check Valves
SH	Shuttle Valves
LM	Load/Motor Controls
FC	Flow Controls
PC	Pressure Controls
LE	Logic Elements
DC	Directional Controls
SV	Solenoid Valves
PV	Proportional Valves
CE	Coils & Electronics
BC	Bodies & Cavities
TD	Technical Data

General Description

Threaded Cartridge Style Counterbalance Valve. Pilot assisted, designed for motion control applications. For additional information see Technical Tips on pages LM2-LM5.

Features

- Poppet construction for minimal leakage
- Incorporates direct acting relief valve for overload protection
- Includes reverse check valve within body, saving space and minimizing installation cost
- Fully sealed pilot for high efficiency and accurate pilot ratio
- Three pilot ratios available, 1.5 :1, 3:1, and 4.5:1
- Hardened working parts for maximum durability
- All external parts zinc plated

Specifications

Rated Flow	60 LPM (16 GPM)
Pressure	40-350 Bar (580-5000 PSI)
Sensitivity: Pressure/Turn	104 Bar (1508 PSI)
Pilot Ratio	E2E1 - 1.5 : 1 E2K1 - 3 : 1 E2M1 - 4.5 : 1
Leakage at 150 SSU (32 cSt)	5 drops/min. (0.33 cc/min) @ 75% of thermal crack pressure
Cartridge Material	All parts steel. All operating parts hardened steel.
Operating Temp. Range/Seals	-34°C to +121°C (Nitrile) (-30°F to +250°F) -26°C to +204°C (Fluorocarbon) (-15°F to +400°F)
Fluid Compatibility/Viscosity	Mineral-based or synthetic with lubricating properties at viscosities of 45 to 2000 SSU (6 to 420 cSt)
Filtration	ISO-4406 18/16/13, SAE Class 4
Approx. Weight	0.17 kg (0.37 lbs.)
Cavity	CAVT11A (See BC Section for more details)

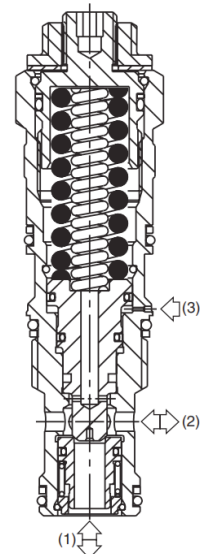
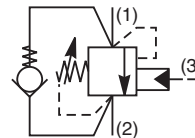
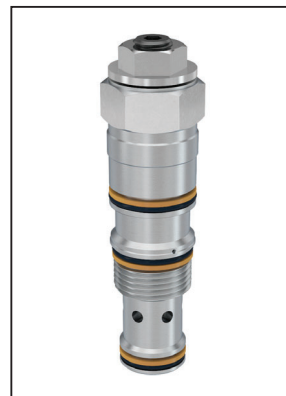

**Performance Curves
 Relief Performance 1 to 2**

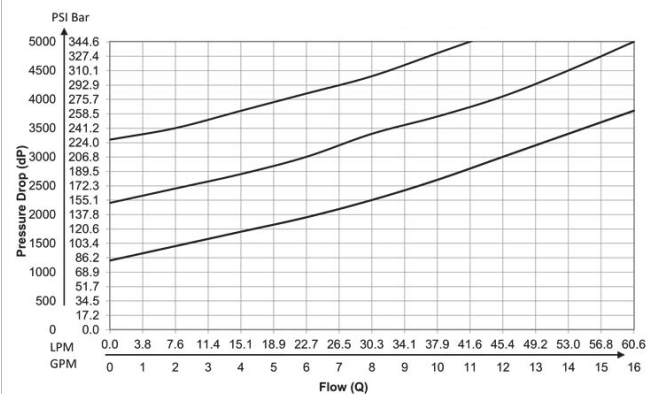

Pressure Drop vs Flow

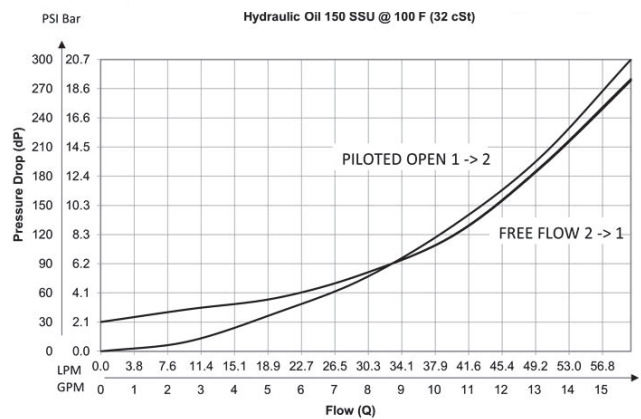

Required Piloted Pressure Calculation

$$P_3 = \left(\frac{P_C - P_1}{P_R} \right) + P_2 * \left(\frac{1}{P_R} + 1 \right)$$

P_C = Crack Pressure Setting
 P_R = Pilot Ratio

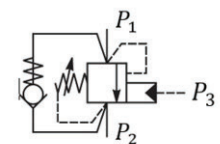

CV
Check Valves

SH
Shuttle Valves

LM
Load/Motor Controls

FC
Flow Controls

PC
Pressure Controls

LE
Logic Elements

DC
Directional Controls

SV
Solenoid Valves

PV
Proportional Valves

CE
Coils & Electronics

BC
Bodies & Cavities

TD
Technical Data

Dimensions Millimeters (Inches)

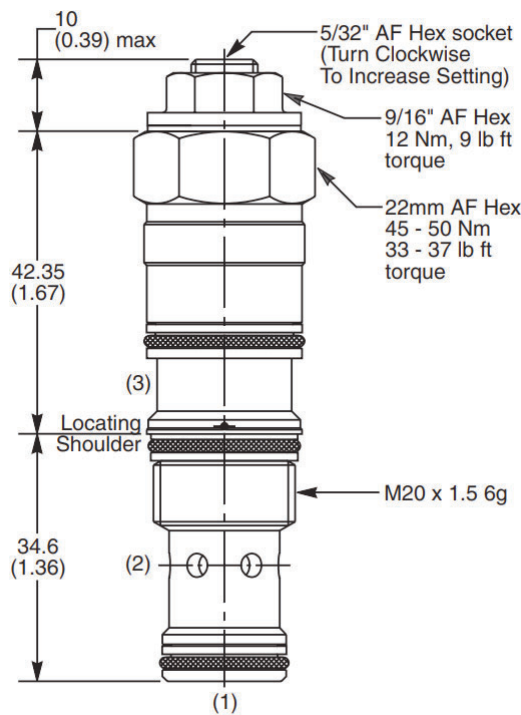

Ordering Information

E2		1	Z	N
Load Control Valve	Pilot Ratio	Adjustment Style	Seals	

Highlighted represents preferred options that offer the shortest lead times. Other options may be available, but at extended lead times.

Code	Pilot Ratio
E	1.5 : 1
K	3 : 1
M	4.5 : 1

Code	Seals
N	Nitrile

Code	Adjustment Style
Z	Screw Adjust (standard)

Order Bodies Separately
 See section BC

LB10	825	S
Line Body	Porting	Body Material

Code	Porting
825	1/2" SAE (main) 1/4" SAE (aux)

Code	Body Material
S	Steel /(5000PSI)

Kit	Part Number
Tamper Resistant Cap	TC1130
Nitrile Seal	SK30008N-1
Fluorocarbon Seal	SK30008V-1

*Standard valve is set to crack at 215 Bar (3120 PSI). Valve to be set to 1.3 times maximum load induced pressure.

CV	Check Valves
SH	Shuttle Valves
LM	Load/Motor Controls
FC	Flow Controls
PC	Pressure Controls
LE	Logic Elements
DC	Directional Controls
SV	Solenoid Valves
PV	Proportional Valves
CE	Coils & Electronics
BC	Bodies & Cavities
TD	Technical Data

General Description

Threaded Cartridge Style Counterbalance Valve, Restrictive Ports 1 to 2. Pilot assisted, designed for motion control applications.

For additional information see Technical Tips on pages LM2-LM5.

Features

- Poppet construction for minimal leakage
- Incorporates direct acting relief valve for overload protection
- Includes reverse check valve within body, saving space and minimizing installation cost
- Fully sealed pilot for high efficiency and accurate pilot ratio
- Two pilot ratios available, 3:1 for cylinders and 4.5:1 for motion control
- Hardened working parts for maximum durability
- All external parts zinc plated

Specifications

Rated Flow	Free flow 60 LPM (16 GPM) Piloted open flow 38 LPM (10 GPM)
Pressure	90-350 Bar (1305-5000 PSI)
Sensitivity: Pressure/Turn	104 Bar (1508 PSI)
Pilot Ratio	E2K1R - 3 : 1 E2M1R - 4.5 : 1
Leakage at 150 SSU (32 cSt)	5 drops/min. (0.33 cc/min) @ 75% of thermal crack pressure
Cartridge Material	All parts steel. All operating parts hardened steel.
Operating Temp. Range/Seals	-34°C to +121°C (Nitrile) (-30°F to +250°F) -26°C to +204°C (Fluorocarbon) (-15°F to +400°F)
Fluid Compatibility/Viscosity	Mineral-based or synthetic with lubricating properties at viscosities of 45 to 2000 SSU (6 to 420 cSt)
Filtration	ISO-4406 18/16/13, SAE Class 4
Approx. Weight	0.17 kg (0.37 lbs.)
Cavity	CAVT11A (See BC Section for more details)

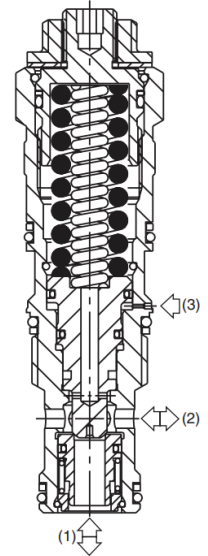
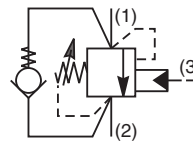
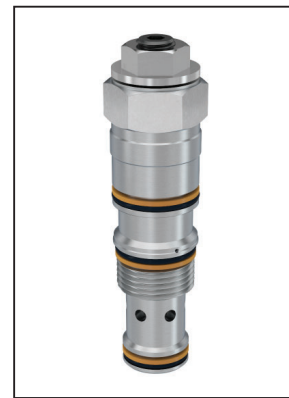

Performance Curves Relief Performance 1 to 2

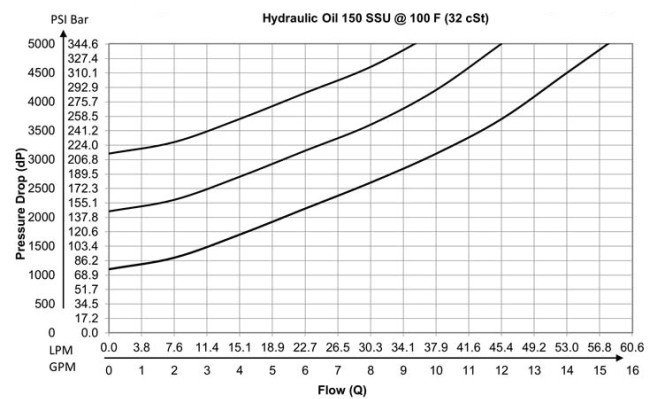

Pressure Drop vs. Flow

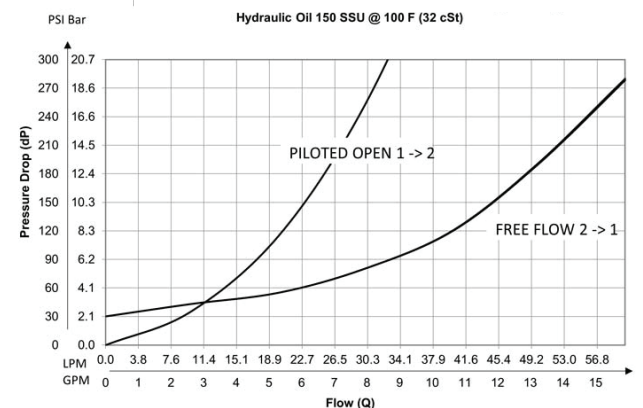

Required Piloted Pressure Calculation

$$P_3 = \left(\frac{P_C - P_1}{P_R} \right) + P_2 * \left(\frac{1}{P_R} + 1 \right)$$

P_C = Crack Pressure Setting
 P_R = Pilot Ratio

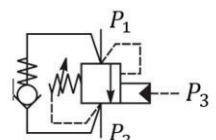



Dimensions Millimeters (Inches)

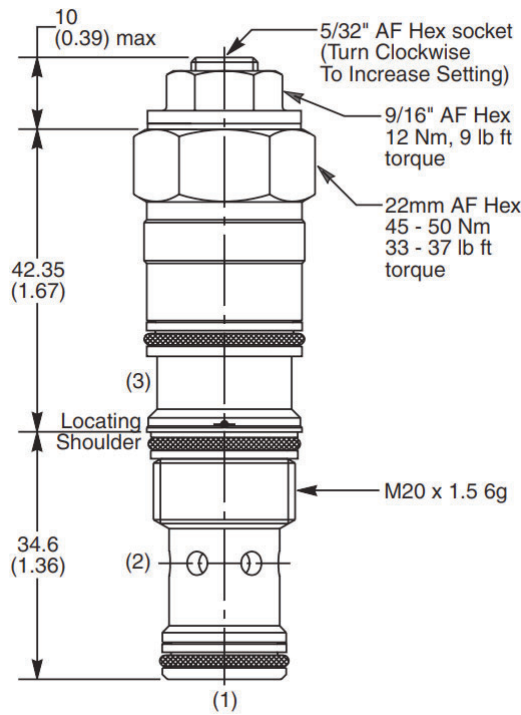

Ordering Information

E2		1R	Z	N
Load Control Valve	Pilot Ratio	Adjustment Style	Seals	

Highlighted represents preferred options that offer the shortest lead times. Other options may be available, but at extended lead times.

Code	Pilot Ratio
K	3 : 1
M	4.5 : 1

Code	Seals
N	Nitrile

Code	Adjustment Style
Z	Screw Adjust (standard)

Order Bodies Separately See section BC

LB10	825	S
Line Body	Porting	Body Material

Code	Porting
825	1/2" SAE (main) 1/4" SAE (aux)

Code	Body Material
S	Steel /(5000PSI)

Kit	Part Number
Tamper Resistant Cap	TC1130
Nitrile Seal	SK30008N-1
Fluorocarbon Seal	SK30008V-1

**Standard valve is set to crack at 215 Bar (3120 PSI). Valve to be set to 1.3 times maximum load induced pressure.*



CV
Check Valves
SH
Shuttle Valves
LM
Load/Motor Controls
FC
Flow Controls
PC
Pressure Controls
LE
Logic Elements
DC
Directional Controls
SV
Solenoid Valves
PV
Proportional Valves
CE
Coils & Electronics
BC
Bodies & Cavities
TD
Technical Data

General Description

Threaded Cartridge Style Counterbalance Valve, Semi-Restrictive Ports 1 to 2. Pilot assisted, designed for motion control applications. For additional information see Technical Tips on pages LM2-LM5.

Features

- Poppet construction for minimal leakage
- Incorporates direct acting relief valve for overload protection
- Includes reverse check valve within body, saving space and minimizing installation cost
- Excellent control and very good stability
- Fully sealed pilot for high efficiency and accurate pilot ratio
- Three pilot ratios available, 1.5:1, 3:1 and 4.5:1
- Hardened working parts for maximum durability
- All external parts zinc plated

Specifications

Rated Flow	Free flow 60 LPM (16 GPM) Piloted open flow 38 LPM (10 GPM)
Pressure	40-350 Bar (580-5000 PSI)
Sensitivity: Pressure/Turn	104 Bar (1508 PSI)
Pilot Ratio	E2E1S - 1.5 : 1 E2K1S - 3 : 1 E2M1S - 4.5 : 1
Leakage at 150 SSU (32 cSt)	5 drops/min. (0.33 cc/min) @ 75% of thermal crack pressure
Cartridge Material	All parts steel. All operating parts hardened steel.
Operating Temp. Range/Seals	-34°C to +121°C (Nitrile) (-30°F to +250°F) -26°C to +204°C (Fluorocarbon) (-15°F to +400°F)
Fluid Compatibility/Viscosity	Mineral-based or synthetic with lubricating properties at viscosities of 45 to 2000 SSU (6 to 420 cSt)
Filtration	ISO-4406 18/16/13, SAE Class 4
Approx. Weight	0.17 kg (0.37 lbs.)
Cavity	CAVT11A (See BC Section for more details)

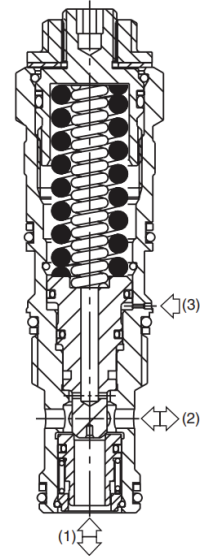
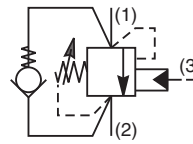
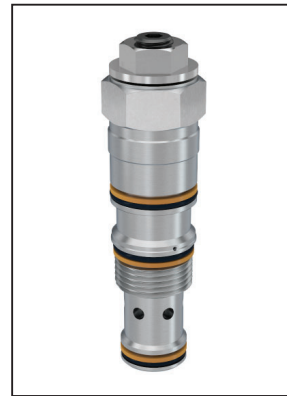

Performance Curves Relief Performance 1 to 2

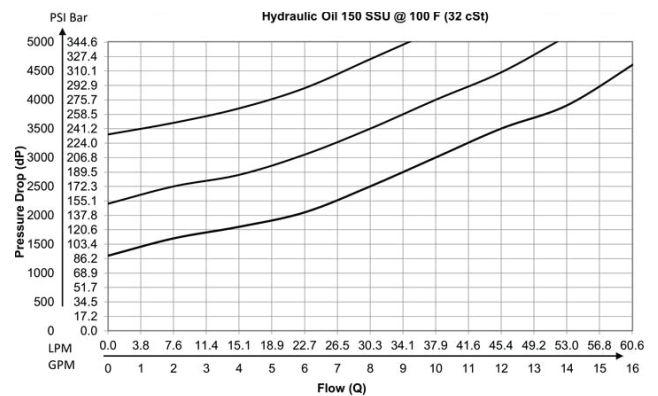

Pressure Drop vs. Flow

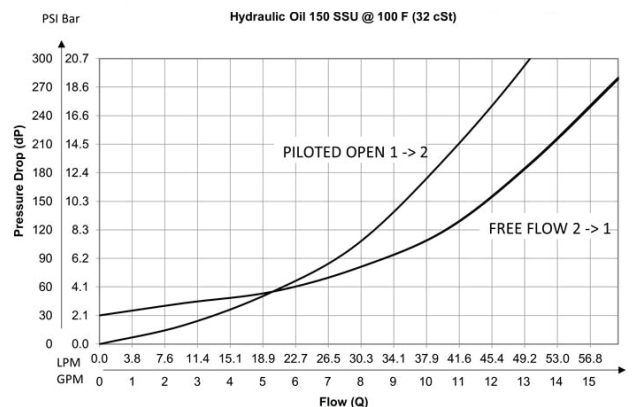

Required Piloted Pressure Calculation

$$P_3 = \left(\frac{P_C - P_1}{P_R} \right) + P_2 * \left(\frac{1}{P_R} + 1 \right)$$

P_C = Crack Pressure Setting
 P_R = Pilot Ratio

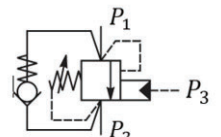

Dimensions Millimeters (Inches)

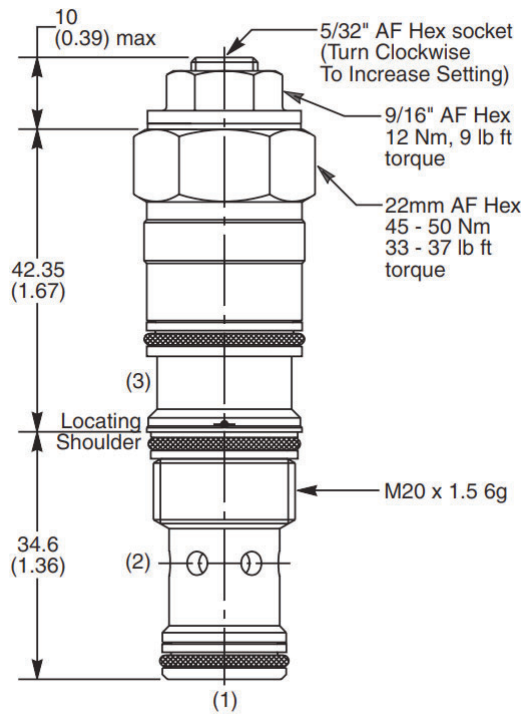

Ordering Information

E2		1S	Z	N
Load Control Valve	Pilot Ratio	Adjustment Style	Seals	

Highlighted represents preferred options that offer the shortest lead times. Other options may be available, but at extended lead times.

Code	Pilot Ratio
E	1.5 : 1
K	3 : 1
M	4.5 : 1

Code	Adjustment Style
Z	Screw Adjust (standard)

Code	Seals
N	Nitrile

Order Bodies Separately See section BC

LB10	825	S
Line Body	Porting	Body Material

Code	Porting
825	1/2" SAE (main) 1/4" SAE (aux)

Code	Body Material
S	Steel /(5000PSI)

Kit	Part Number
Tamper Resistant Cap	TC1130
Nitrile Seal	SK30008N-1
Fluorocarbon Seal	SK30008V-1

**Standard valve is set to crack at 215 Bar (3120 PSI). Valve to be set to 1.3 times maximum load induced pressure.*

CV	Check Valves
SH	Shuttle Valves
LM	Load/Motor Controls
FC	Flow Controls
PC	Pressure Controls
LE	Logic Elements
DC	Directional Controls
SV	Solenoid Valves
PV	Proportional Valves
CE	Coils & Electronics
BC	Bodies & Cavities
TD	Technical Data

General Description

Cartridge Style Counterbalance Valve.
 For additional information see Technical Tips
 on pages LM2-LM5.

Features

- Sealed spool type design for improved stability and accuracy as well as low leakage
- Low leakage poppet-type check valve for reliable load holding
- All external parts zinc plated
- Parker cartridge design for ease of installation and maintenance
- Compact size for reduced space requirements

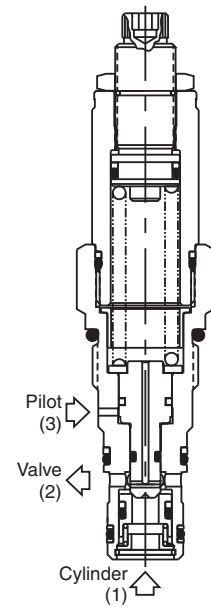
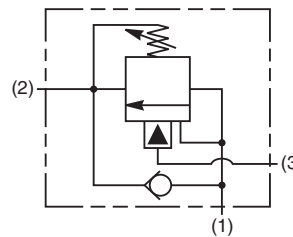
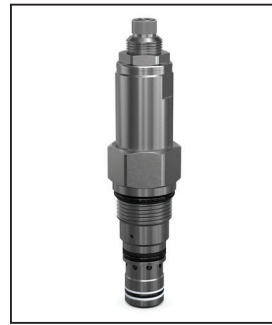

Specifications

Rated Flow	45 LPM (12 GPM)
Maximum Inlet Pressure	380 Bar (5500 PSI) - Steel 210 Bar (3000 PSI) - Aluminium
Maximum Setting Pressure	350 Bar (5000 PSI) - Steel 210 Bar (3000 PSI) - Aluminium
Leakage at 150 SSU (32 cSt)	5 drops/min. (0.33 cc/min) @ 80% of thermal crack pressure
Cartridge Material	All parts steel. All operating parts hardened steel.
Operating Temp. Range/Seals	-34°C to +121°C (Nitrile) (-30°F to +250°F) -26°C to +204°C (Fluorocarbon) (-15°F to +400°F)
Fluid Compatibility/Viscosity	Mineral-based or synthetic with lubricating properties at viscosities of 45 to 2000 SSU (6 to 420 cSt)
Filtration	ISO-4406 18/16/13, SAE Class 4
Approx. Weight	0.23 kg (0.5 lbs.)
Cavity	C10-3 (See BC Section for more details)

Performance Curve
Flow vs. Pressure Drop
 (Through cartridge only)

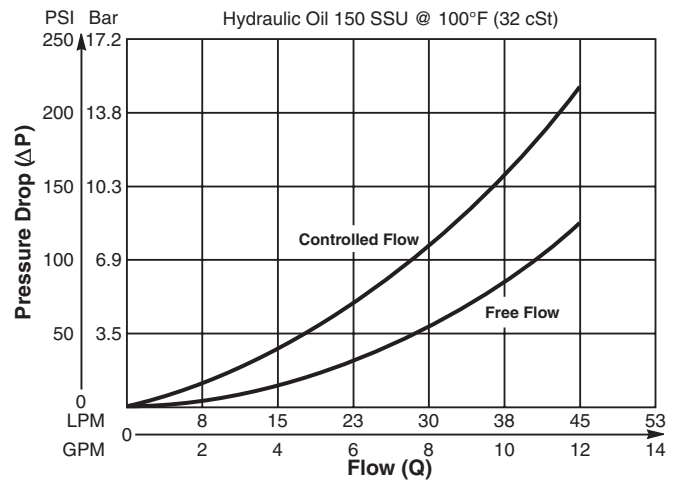

CV
Check Valves

SH
Shuttle Valves

LM
Load/Motor Controls

FC
Flow Controls

PC
Pressure Controls

LE
Logic Elements

DC
Directional Controls

SV
Solenoid Valves

PV
Proportional Valves

CE
Coils & Electronics

BC
Bodies & Cavities

TD
Technical Data

Dimensions Millimeters (Inches)

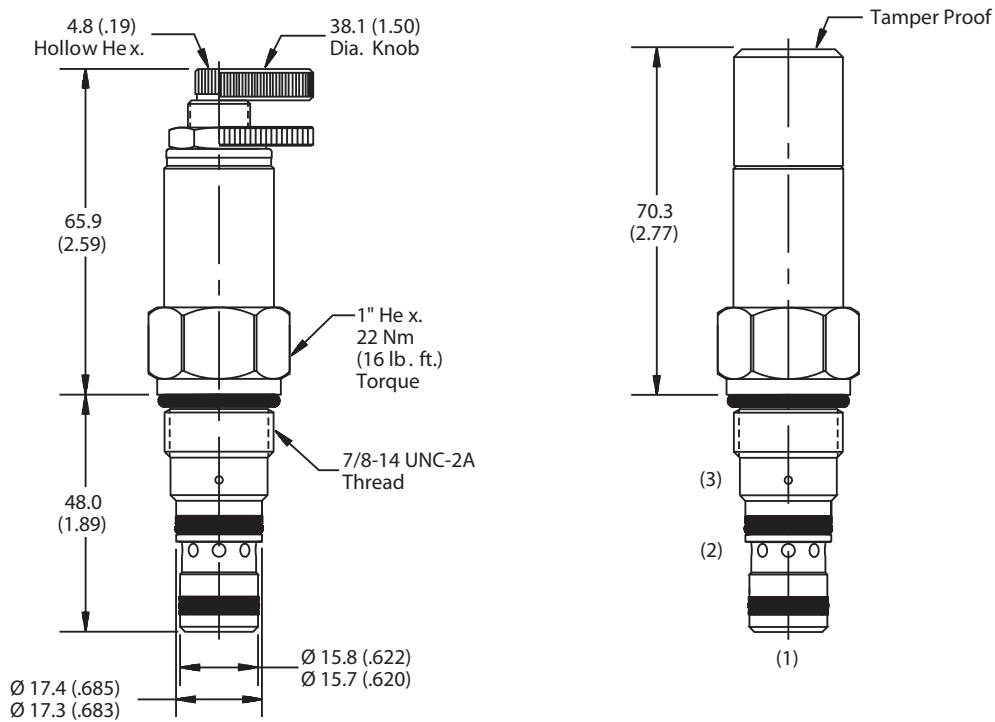

Ordering Information

CB101		S	
Counterbalance Cartridge Valve	Pilot Ratio	Adjustment Style	Pressure Range

Highlighted represents preferred options that offer the shortest lead times. Other options may be available, but at extended lead times.

Code	Pilot Ratio
A	3 : 1
B	4.5 : 1
C	7 : 1

Code	Adjustment Style
S	Screw Adjust

Code	Pressure Range
10	34.5 to 103.4 Bar (500 to 1500 PSI) Standard Setting: 69 Bar (1000 PSI) @ 11.3 LPM (3 GPM)
20	69 to 172.4 Bar (1000 to 2500 PSI) Standard Setting: 138 Bar (2000 PSI) @ 11.3 LPM (3 GPM)
30	166 to 350 Bar (2400 to 5000 PSI) Standard Setting: 210 Bar (3000 PSI) @ 11.3 LPM (3 GPM)

Code	Seals
Omit	Nitrile

Order Bodies Separately
 See section BC

B10	—	3	—	8T
10 size		3-Way Cavity		Port Size

Code	Port Size / Body Material
8T	SAE-8 / Steel (5000 PSI)

Kit	Part Number
Knob	717784-10
Tamper Resistant Cap	717785
Nitrile Seal	SK10-3
Fluorocarbon Seal	SK10-3V

CV	Check Valves
SH	Shuttle Valves
LM	Load/Motor Controls
FC	Flow Controls
PC	Pressure Controls
LE	Logic Elements
DC	Directional Controls
SV	Solenoid Valves
PV	Proportional Valves
CE	Coils & Electronics
BC	Bodies & Cavities
TD	Technical Data

General Description

Threaded Cartridge Style Counterbalance Valve.
 For additional information see Technical Tips
 on pages LM2-LM5.

Features

- Conical Poppet design provides longer metering stroke for stable operation
- Hardened seat provides reliable load holding
- External vent option available for high back pressure applications
- Tamper resistant cap for added safety and security
- Various pilot ratios available for application flexibility
- Unique cavity prevents other valves from being “accidentally” installed

Specifications

Rated Flow	37.5 LPM (10 GPM)
Maximum Inlet Pressure	350 Bar (5000 PSI)
Leakage at 150 SSU (32 cSt)	5 drops/min. (0.33 cc/min) @ 80% of thermal crack pressure
Cartridge Material	All parts steel. All operating parts hardened steel.
Operating Temp. Range/Seals	-34°C to +121°C (Nitrile) (-30°F to +250°F) -26°C to +204°C (Fluorocarbon) (-15°F to +400°F)
Fluid Compatibility/Viscosity	Mineral-based or synthetic with lubricating properties at viscosities of 45 to 2000 SSU (6 to 420 cSt)
Filtration	ISO-4406 18/16/13, SAE Class 4
Approx. Weight	0.38 kg (0.88 lbs.)
Cavity	CDD-1010 (See BC Section for more details)

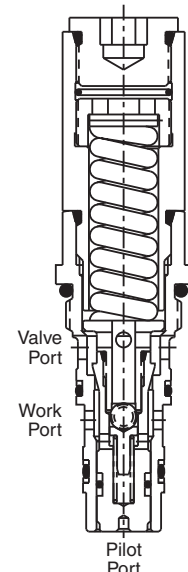
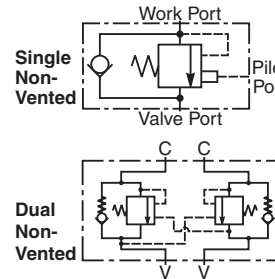

MHC-010-S*S* Non-Vented Counterbalance Adjustable

Construction

MHC-010-V*S* Vented Counterbalance Adjustable

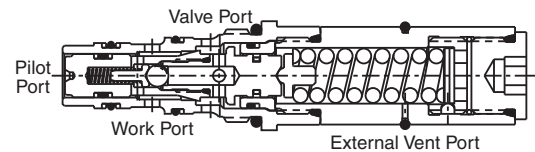

MHC-010-S*N* Non-Vented Counterbalance Non-Adjustable

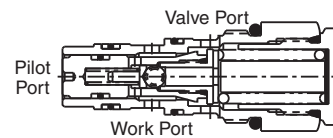

MHC-010-V*N* Vented Counterbalance Non-Adjustable

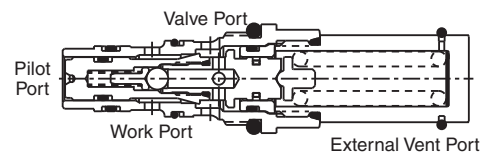

Performance Curve

Flow vs. Pressure Drop (Through cartridge only)

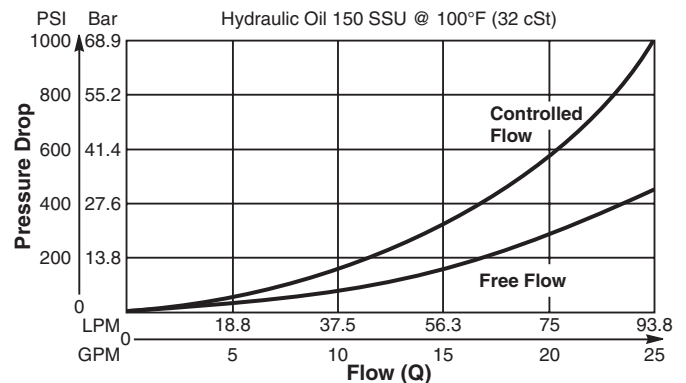

CV
Check Valves

SH
Shuttle Valves

LM
Load/Motor Controls

FC
Flow Controls

PC
Pressure Controls

LE
Logic Elements

DC
Directional Controls

SV
Solenoid Valves

PV
Proportional Valves

CE
Coils & Electronics

BC
Bodies & Cavities

TD
Technical Data

Dimensions Millimeters (Inches)

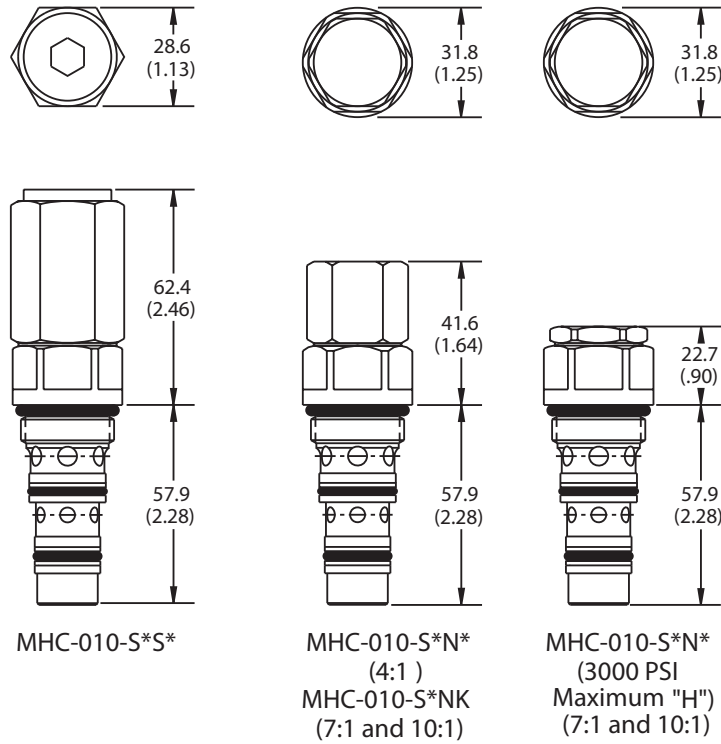

Torque Values
 68-75 Nm (50-55 lb. ft.)
 Typical for all

Ordering Information

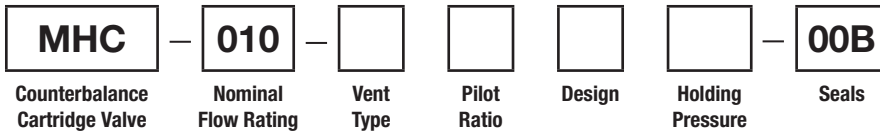

Highlighted represents preferred options that offer the shortest lead times. Other options may be available, but at extended lead times.

Code	Nominal Flow Rating
010	37.5 LPM (10 GPM)
Code	Vent Type
S	Standard (non-vented)
V	Vented
Code	Pilot Ratio
F	7 : 1 (Standard)
J	10 : 1
Code	Design
S	Standard (adjustable)
N	Shimmed (non-adjustable)

Code	Holding Pressure
H	210 Bar (3000 PSI) Standard version
K	350 Bar (5000 PSI) Standard Setting: 7:1 and 10:1 only Shim version only
Code	Seals
00B	Nitrile

Kit	Part Number
Nitrile Seal	711922
Fluorocarbon Seal	711825

Order Bodies Separately
 See section BC

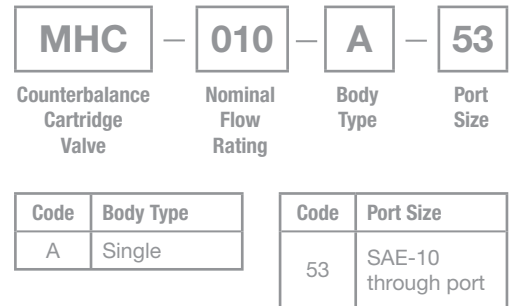

CV
Check Valves

SH
Shuttle Valves

LM
Load/Motor Controls

FC
Flow Controls

PC
Pressure Controls

LE
Logic Elements

DC
Directional Controls

SV
Solenoid Valves

PV
Proportional Valves

CE
Coils & Electronics

BC
Bodies & Cavities

TD
Technical Data

General Description

Threaded Cartridge Style Counterbalance Valve. Pilot assisted, designed for motion control applications. For additional information see Technical Tips on pages LM2-LM5.

Features

- Poppet construction for minimal leakage
- Incorporates direct acting relief valve for overload protection
- Includes reverse check valve within body, saving space and minimizing installation cost
- Can be directly mounted into cylinder eliminating requirement for manifold block
- Fully sealed pilot for high efficiency and accurate pilot ratio
- Two pilot ratios available, 4.5:1 for cylinders and 8:1 for motor control
- All external parts zinc plated

Specifications

Rated Flow	E2A020 14 LPM (3.7 GPM) E2B020 20 LPM (5.3 GPM)
Pressure	50 to 420 Bar (725 to 6000 PSI)
Sensitivity: Pressure / Turn	E2A020 113 Bar (1640 PSI) E2B020 84 Bar (1220 PSI)
Cartridge Material	All parts steel. All operating parts hardened steel.
Operating Temp. Range/Seals	-34°C to +121°C (Nitrile) (-30°F to +250°F) -26°C to +204°C (Fluorocarbon) (-15°F to +400°F)
Fluid Compatibility/Viscosity	Mineral-based or synthetic with lubricating properties at viscosities of 45 to 2000 SSU (6 to 420 cSt)
Filtration	ISO-4406 18/16/13, SAE Class 4
Approx. Weight	0.08 kg (0.17 lbs.)
Cavity	53-1 (See BC Section for more details)

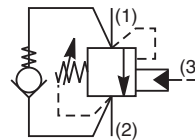
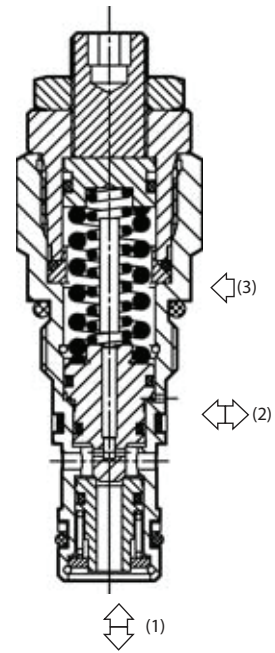

Performance Curves

Relief & Pilot Performance 1 to 2

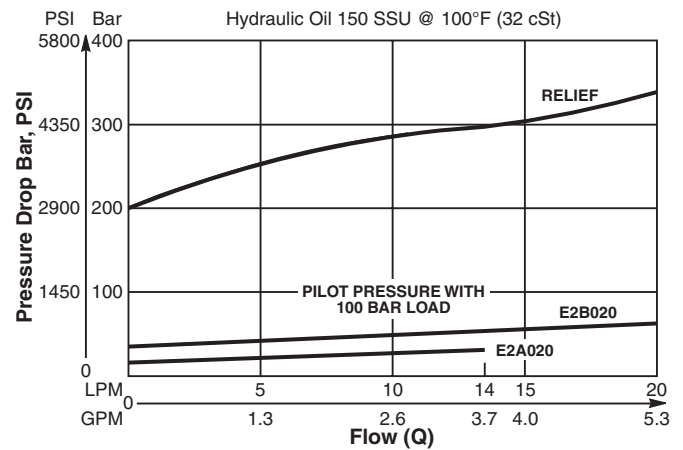

Pressure Drop vs Flow

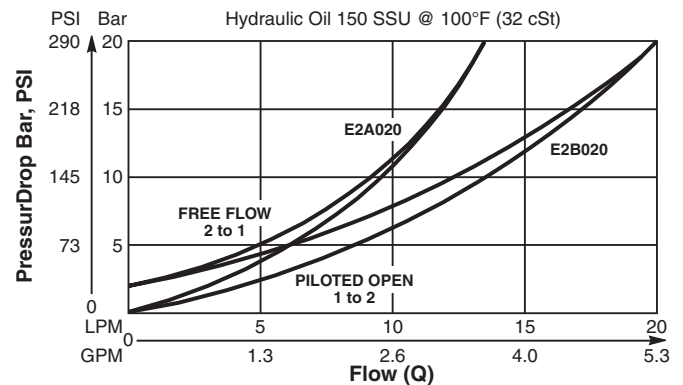

CV
Check Valves

SH
Shuttle Valves

LM
Load/Motor Controls

FC
Flow Controls

PC
Pressure Controls

LE
Logic Elements

DC
Directional Controls

SV
Solenoid Valves

PV
Proportional Valves

CE
Coils & Electronics

BC
Bodies & Cavities

TD
Technical Data

Dimensions Millimeters (Inches)

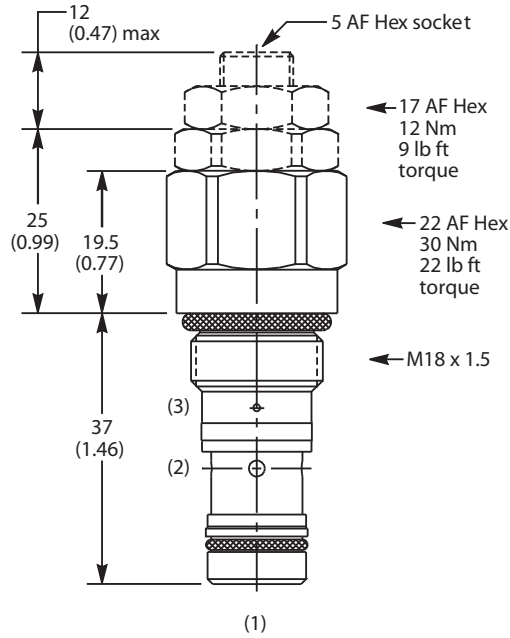

Ordering Information

E2		020	Z	N
Load Control Valve	Pilot Ratio		Adjustment Style	Seals

Highlighted represents preferred options that offer the shortest lead times. Other options may be available, but at extended lead times.

Code	Pilot Ratio
A	8 : 1
B	4.5 : 1

Code	Adjustment Style
Z	Screw Adjust (Standard)

Code	Seals
N	Nitrile

Kit	Part Number
Tamper Resistant Cap	TC1130
Nitrile Seal	SK30087N-1
Fluorocarbon Seal	SK30087V-1

Order Bodies Separately See section BC

LB10	318	S
Line Body	Porting	Body Material

Code	Porting
318	3/8" SAE (main) 1/4" SAE (aux)

Code	Body Material
S	Steel /(5000PSI)

*Standard valve is set to crack at 215 Bar (3120 PSI). Valve to be set to 1.3 times maximum load induced pressure.



CV	Check Valves
SH	Shuttle Valves
LM	Load/Motor Controls
FC	Flow Controls
PC	Pressure Controls
LE	Logic Elements
DC	Directional Controls
SV	Solenoid Valves
PV	Proportional Valves
CE	Coils & Electronics
BC	Bodies & Cavities
TD	Technical Data

General Description

Threaded Cartridge Style Counterbalance Valve.
 Pilot assisted, designed for motion control applications
 For additional information see Technical Tips on pages LM2-LM5.

Features

- Poppet construction for minimal leakage
- Incorporates direct acting relief valve for overload protection
- Includes reverse check valve within body, saving space and minimizing installation cost
- Two pilot ratios available, 3:1 for cylinders and 8:1 for motor control
- Hardened working parts for maximum durability
- All external parts zinc plated

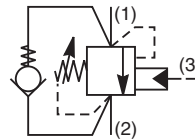
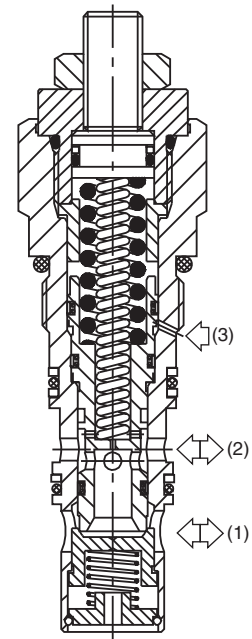

Specifications

Rated Flow	60 LPM (15.9 GPM)
Pressure	50 - 350 Bar (725 - 5000 PSI)
Sensitivity: Pressure / Turn	99 Bar (1435 PSI)
Pilot Ratio	E2A040 - 8 : 1 E2B040 - 3 : 1
Cartridge Material	All parts steel. All operating parts hardened steel.
Operating Temp. Range/Seals	-34°C to +121°C (Nitrile) (-30°F to +250°F) -26°C to +204°C (Fluorocarbon) (-15°F to +400°F)
Fluid Compatibility/Viscosity	Mineral-based or synthetic with lubricating properties at viscosities of 45 to 2000 SSU (6 to 420 cSt)
Filtration	ISO-4406 18/16/13, SAE Class 4
Approx. Weight	0.27 kg (0.6 lbs.)
Cavity	68-1 (See BC Section for more details)

Performance Curves

Relief & Pilot Performance 1 to 2

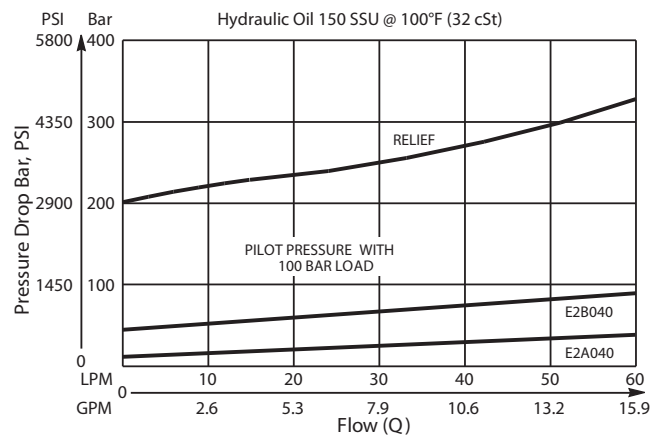

Pressure Drop vs Flow

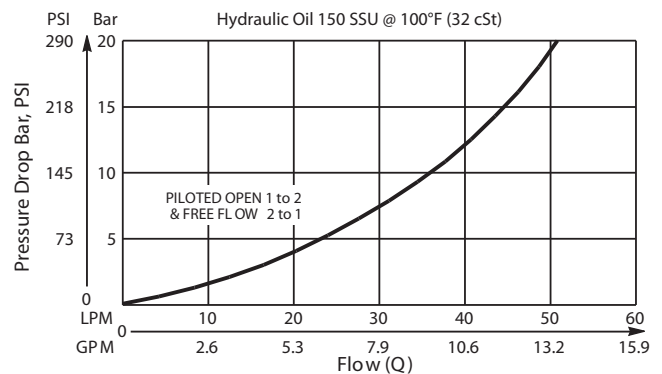

CV
Check Valves

SH
Shuttle Valves

LM
Load/Motor Controls

FC
Flow Controls

PC
Pressure Controls

LE
Logic Elements

DC
Directional Controls

SV
Solenoid Valves

PV
Proportional Valves

CE
Coils & Electronics

BC
Bodies & Cavities

TD
Technical Data

Dimensions Millimeters (Inches)

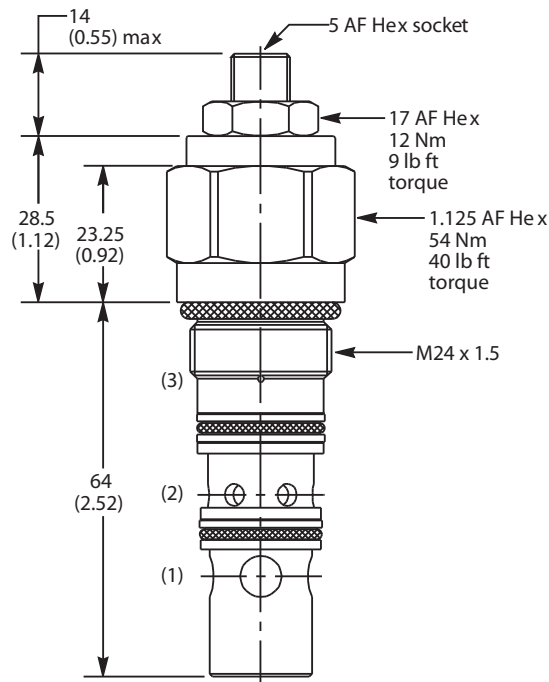

Ordering Information

E2		040	Z	N	MK3
Load Control Valve	Pilot Ratio		Adjustment Style	Seals	

Highlighted represents preferred options that offer the shortest lead times. Other options may be available, but at extended lead times.

Code	Pilot Ratio
A	8 : 1
B	3 : 1

Code	Adjustment Style
Z	Screw Adjust (Standard)

Code	Seals
N	Nitrile

Kit	Part Number
Tamper Resistant Cap	TC1130
Nitrile Seal	SK30059N-1
Fluorocarbon Seal	SK30059V-1

Order Bodies Separately
 See section BC

LB10	253	S
Line Body	Porting	Body Material

Code	Porting
253	1/2" SAE (main) 1/4" SAE (aux)

Code	Body Material
S	Steel /(5000PSI)

*Standard valve is set to crack at 215 Bar (3120 PSI). Valve to be set to 1.3 times maximum load induced pressure.



CV	Check Valves
SH	Shuttle Valves
LM	Load/Motor Controls
FC	Flow Controls
PC	Pressure Controls
LE	Logic Elements
DC	Directional Controls
SV	Solenoid Valves
PV	Proportional Valves
CE	Coils & Electronics
BC	Bodies & Cavities
TD	Technical Data

General Description

Threaded Cartridge Style Counterbalance Valve.
 Pilot assisted, designed for motion control applications
 For additional information see Technical Tips on pages LM2-LM5.

Features

- Poppet construction for minimal leakage
- Incorporates direct acting relief valve for overload protection
- Includes reverse check valve within body, saving space and minimizing installation cost
- Excellent control and very good stability
- Three pilot ratios available, 1.75:1 and 3:1 for cylinders and 8:1 for motor control
- Hardened working parts for maximum durability
- All external parts zinc plated

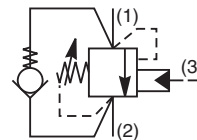
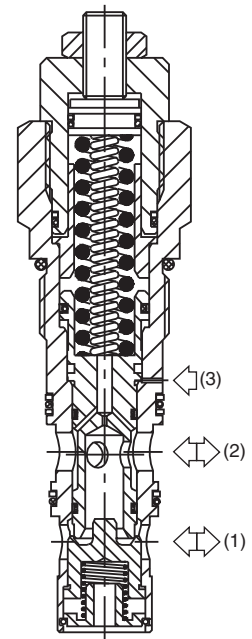

Specifications

Rated Flow	120 LPM (32 GPM)
Pressure	50 - 350 Bar (725 - 5000 PSI)
Sensitivity: Pressure / Turn	44 Bar (640 PSI)
Pilot Ratio	E2A060 - 8 : 1 E2B060 - 3 : 1 E2H060 - 1.75 : 1
Cartridge Material	All parts steel. All operating parts hardened steel.
Operating Temp. Range/Seals	-34°C to +121°C (Nitrile) (-30°F to +250°F) -26°C to +204°C (Fluorocarbon) (-15°F to +400°F)
Fluid Compatibility/ Viscosity	Mineral-based or synthetic with lubricating properties at viscosities of 45 to 2000 SSU (6 to 420 cSt)
Filtration	ISO-4406 18/16/13, SAE Class 4
Approx. Weight	0.54 kg (1.19 lbs.)
Cavity	3C (See BC Section for more details)

Performance Curves

Relief & Pilot Performance 1 to 2

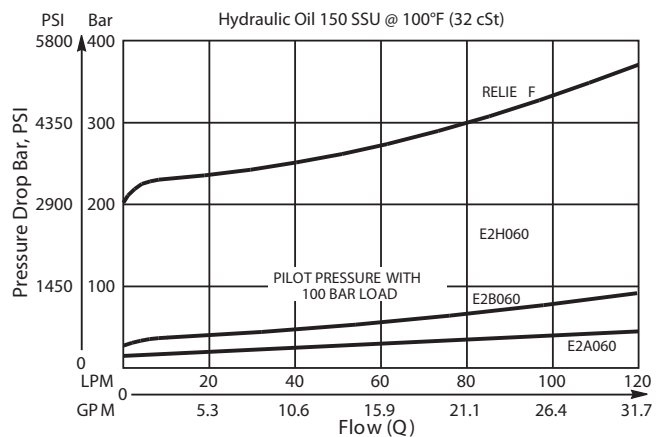

Pressure Drop vs Flow

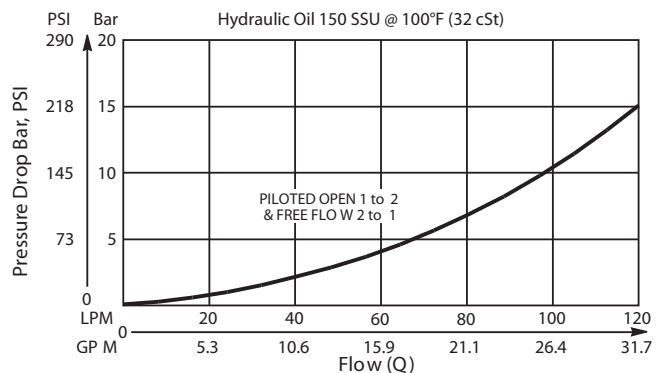

CV
Check Valves

SH
Shuttle Valves

LM
Load/Motor Controls

FC
Flow Controls

PC
Pressure Controls

LE
Logic Elements

DC
Directional Controls

SV
Solenoid Valves

PV
Proportional Valves

CE
Coils & Electronics

BC
Bodies & Cavities

TD
Technical Data

Dimensions Millimeters (Inches)

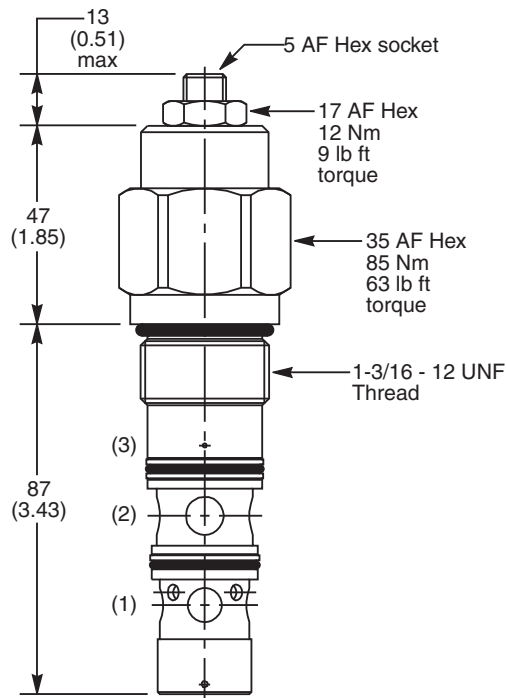

Ordering Information

E2		060	Z	N	MK2
Load Control Valve	Pilot Ratio		Adjustment Style	Seals	

Highlighted represents preferred options that offer the shortest lead times. Other options may be available, but at extended lead times.

Code	Pilot Ratio
A	8 : 1
B	3 : 1
H	1.75 : 1

Code	Adjustment Style
Z	Screw Adjust (Standard)

Code	Seals
N	Nitrile

Kit	Part Number
Tamper Resistant Cap	TC1130
Nitrile Seal	SK30008N-1
Fluorocarbon Seal	SK30008V-1

Order Bodies Separately
 See section BC

LB10	069	S
Line Body	Porting	Body Material

Code	Porting
069	1" SAE (main) 1/4" SAE (aux)

Code	Body Material
S	Steel / (5000PSI)

*Standard valve is set to crack at 215 Bar (3120 PSI). Valve to be set to 1.3 times maximum load induced pressure.



CV	Check Valves
SH	Shuttle Valves
LM	Load/Motor Controls
FC	Flow Controls
PC	Pressure Controls
LE	Logic Elements
DC	Directional Controls
SV	Solenoid Valves
PV	Proportional Valves
CE	Coils & Electronics
BC	Bodies & Cavities
TD	Technical Data

General Description

Threaded Cartridge Style Counterbalance Valve.
 Pilot assisted, designed for motion control applications
 For additional information see Technical Tips on pages LM2-LM5.

Features

- Poppet construction for minimal leakage
- Incorporates direct acting relief valve for overload protection, and reverse check valve, saving space and minimizing installation cost
- Two pilot ratios available, 3:1 for cylinders and 8:1 for motor control
- Hardened working parts for maximum durability
- All external parts zinc plated

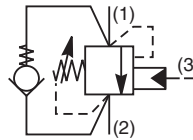
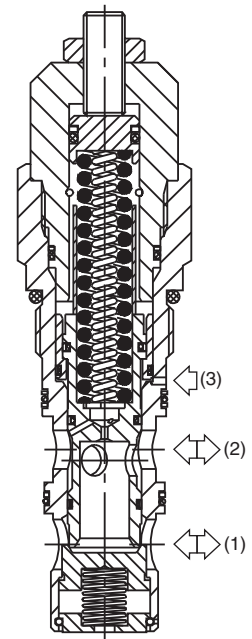

Specifications

Rated Flow	200 LPM (53 GPM)
Pressure	50 - 350 Bar (725 - 5000 PSI)
Sensitivity: Pressure / Turn	34 Bar (493 PSI)
Pilot Ratio	E2A125 - 8 : 1 E2E125 - 3 : 1
Cartridge Material	All parts steel. All operating parts hardened steel.
Operating Temp. Range/Seals	-34°C to +121°C (Nitrile) (-30°F to +250°F) -26°C to +204°C (Fluorocarbon) (-15°F to +400°F)
Fluid Compatibility/ Viscosity	Mineral-based or synthetic with lubricating properties at viscosities of 45 to 2000 SSU (6 to 420 cSt)
Filtration	ISO-4406 18/16/13, SAE Class 4
Approx. Weight	0.75 kg (1.65 lbs.)
Cavity	3M (See BC Section for more details)

Performance Curves

Relief & Pilot Performance 1 to 2

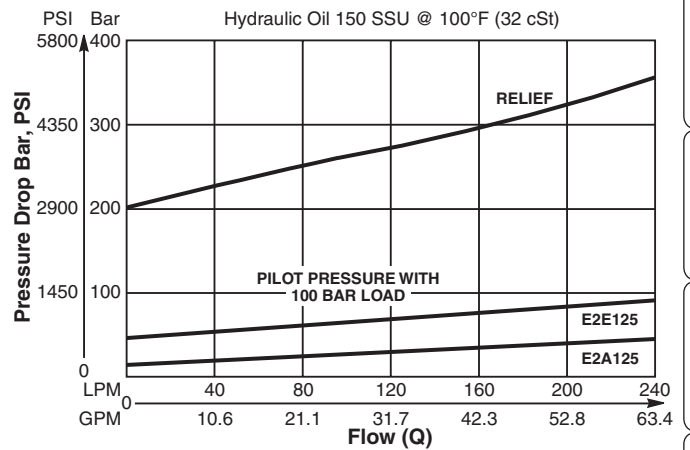

Pressure Drop vs Flow

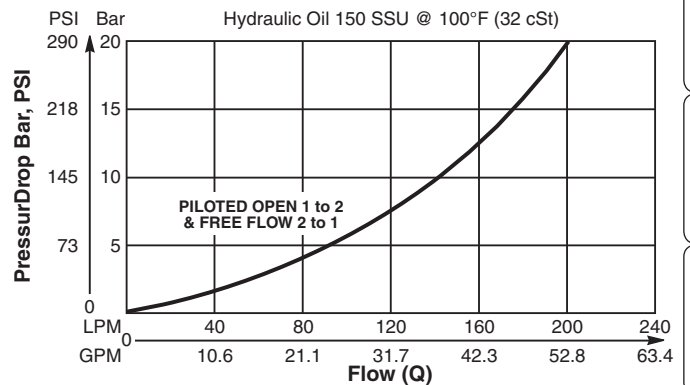

CV
Check Valves

SH
Shuttle Valves

LM
Load/Motor Controls

FC
Flow Controls

PC
Pressure Controls

LE
Logic Elements

DC
Directional Controls

SV
Solenoid Valves

PV
Proportional Valves

CE
Coils & Electronics

BC
Bodies & Cavities

TD
Technical Data

Dimensions Millimeters (Inches)

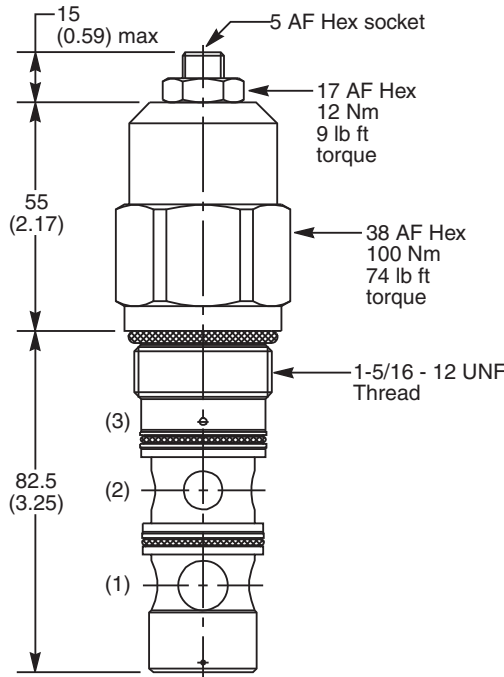

Ordering Information

E2		125	Z	N	MK2
Load Control Valve	Pilot Ratio		Adjustment Style	Seals	

Highlighted represents preferred options that offer the shortest lead times. Other options may be available, but at extended lead times.

Code	Pilot Ratio
A	8 : 1
E	3 : 1

Code	Adjustment Style
Z	Screw Adjust (Standard)

Code	Seals
N	Nitrile

Kit	Part Number
Tamper Resistant Cap	TC1130
Nitrile Seal	SK30035N-1
Fluorocarbon Seal	SK30035V-1

Order Bodies Separately
 See section BC

LB10	078	S
Line Body	Porting	Body Material

Code	Porting
078	1" SAE (main) 1/4" SAE (aux)

Code	Body Material
S	Steel / (5000PSI)

*Standard valve is set to crack at 215 Bar (3120 PSI). Valve to be set to 1.3 times maximum load induced pressure.



CV	Check Valves
SH	Shuttle Valves
LM	Load/Motor Controls
FC	Flow Controls
PC	Pressure Controls
LE	Logic Elements
DC	Directional Controls
SV	Solenoid Valves
PV	Proportional Valves
CE	Coils & Electronics
BC	Bodies & Cavities
TD	Technical Data

General Description

Threaded Cartridge Style Counterbalance Valve.
 Pilot assisted, designed for motion control applications
 For additional information see Technical Tips on pages LM2-LM5.

Features

- Poppet construction for minimal leakage
- Incorporates direct acting relief valve for overload protection, and reverse check valve, saving space and minimizing installation cost
- Two pilot ratios available, 3:1 for cylinders and 8:1 for motor control
- Hardened working parts for maximum durability
- All external parts zinc plated

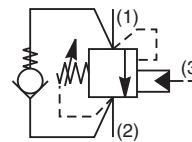
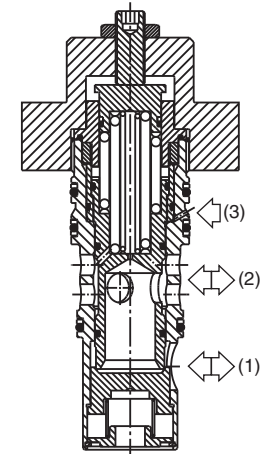
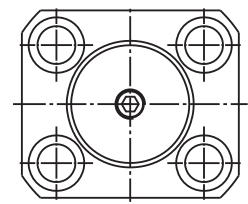

Specifications

Rated Flow	350 LPM (92 GPM)
Pressure	50 to 350 Bar (725 to 5000 PSI)
Sensitivity: Pressure / Turn	45 Bar (653 PSI)
Pilot Ratio	E2A300 - 8 : 1 E2C300 - 3 : 1
Cartridge Material	All parts steel. All operating parts hardened steel.
Operating Temp. Range/Seals	-34°C to +121°C (Nitrile) (-30°F to +250°F) -26°C to +204°C (Fluorocarbon) (-15°F to +400°F)
Fluid Compatibility/ Viscosity	Mineral-based or synthetic with lubricating properties at viscosities of 45 to 2000 SSU (6 to 420 cSt)
Filtration	ISO-4406 18/16/13, SAE Class 4
Approx. Weight	1.44 kg (3.17 lbs.)
Cavity	3K (See BC Section for more details)

Performance Curves

Relief & Pilot Performance 1 to 2

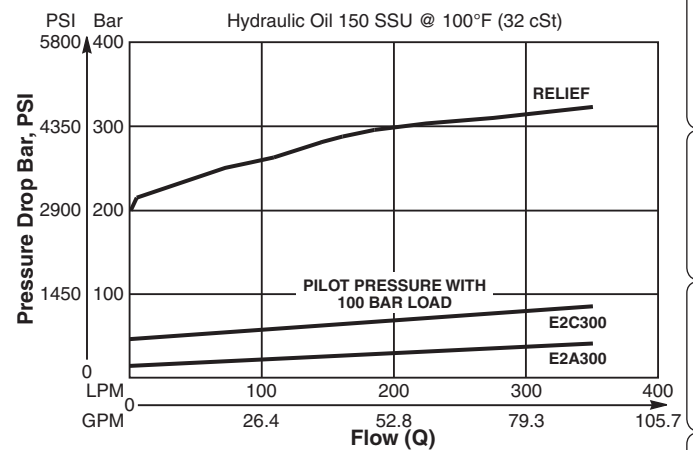

Pressure Drop vs Flow

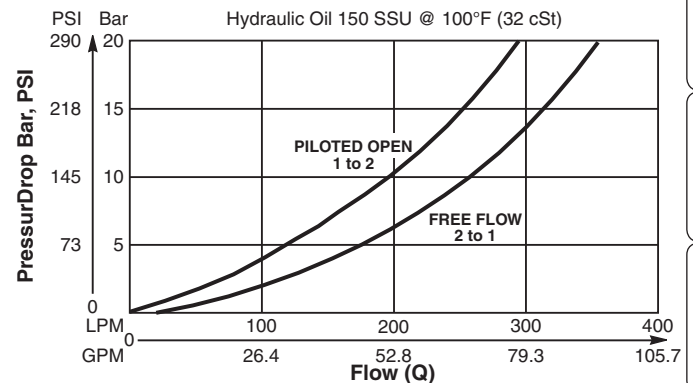

CV
Check Valves

SH
Shuttle Valves

LM
Load/Motor Controls

FC
Flow Controls

PC
Pressure Controls

LE
Logic Elements

DC
Directional Controls

SV
Solenoid Valves

PV
Proportional Valves

CE
Coils & Electronics

BC
Bodies & Cavities

TD
Technical Data

Dimensions Millimeters (Inches)

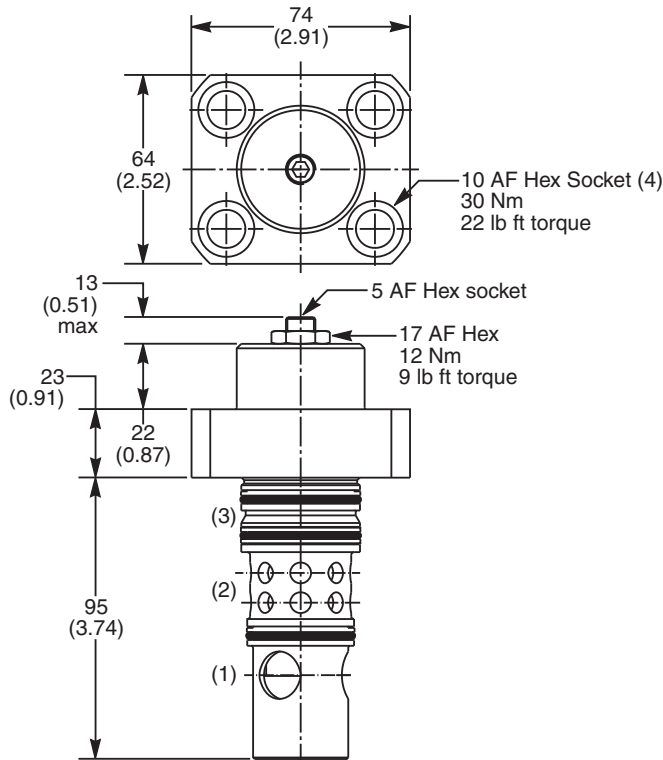

Ordering Information

E2		300	Z	N	MK2
Load Control Valve	Pilot Ratio		Adjustment Style	Seals	

Highlighted represents preferred options that offer the shortest lead times. Other options may be available, but at extended lead times.

Code	Pilot Ratio
A	8 : 1
C	3 : 1

Code	Adjustment Style
Z	Screw Adjust (Standard)

Code	Seals
N	Nitrile

Kit	Part Number
Tamper Resistant Cap	TC1130
Nitrile Seal	SK30022N-1
Fluorocarbon Seal	SK30022V-1

Order Bodies Separately
 See section BC

LB10	089	S
Line Body	Porting	Body Material

Code	Porting
089	1-1/4" BSP (main) 1/4" BSP (aux)

Code	Body Material
S	Steel / (5000PSI)

*Standard valve is set to crack at 215 Bar (3120 PSI). Valve to be set to 1.3 times maximum load induced pressure.



CV
Check Valves
SH
Shuttle Valves
LM
Load/Motor Controls
FC
Flow Controls
PC
Pressure Controls
LE
Logic Elements
DC
Directional Controls
SV
Solenoid Valves
PV
Proportional Valves
CE
Coils & Electronics
BC
Bodies & Cavities
TD
Technical Data

General Description

Threaded Cartridge Style Counterbalance Valve.
 Pilot assisted, designed for motion control applications
 For additional information see Technical Tips on pages LM2-LM5.

Features

- Spring chamber isolated from system backpressure by double seal, eliminating vent port leakage and need for separate drain line
- Poppet construction for minimal leakage
- Incorporates direct acting relief valve for overload protection
- Includes reverse check valve within body
- Small and compact, can be fitted directly into cylinder
- All external parts zinc plated

Specifications

Rated Flow	20 LPM (5.3 GPM)
Pressure	50 to 420 Bar (725 to 6000 PSI)
Sensitivity: Pressure / Turn	84 Bar (1220 PSI)
Pilot Ratio	4.5 : 1
Cartridge Material	All parts steel. All operating parts hardened steel.
Operating Temp. Range/Seals	-34°C to +121°C (Nitrile) (-30°F to +250°F) -26°C to +204°C (Fluorocarbon) (-15°F to +400°F)
Fluid Compatibility/Viscosity	Mineral-based or synthetic with lubricating properties at viscosities of 45 to 2000 SSU (6 to 420 cSt)
Filtration	ISO-4406 18/16/13, SAE Class 4
Approx. Weight	0.08 kg (0.18 lbs.)
Cavity	53-1 (See BC Section for more details)

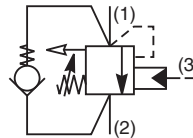
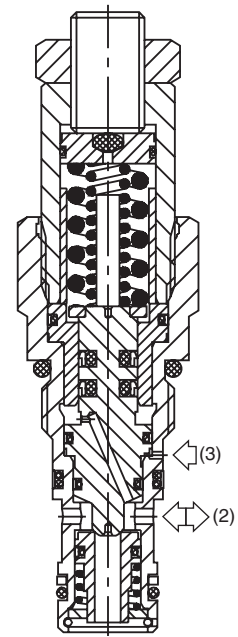

Performance Curves

Relief & Pilot Performance 1 to 2

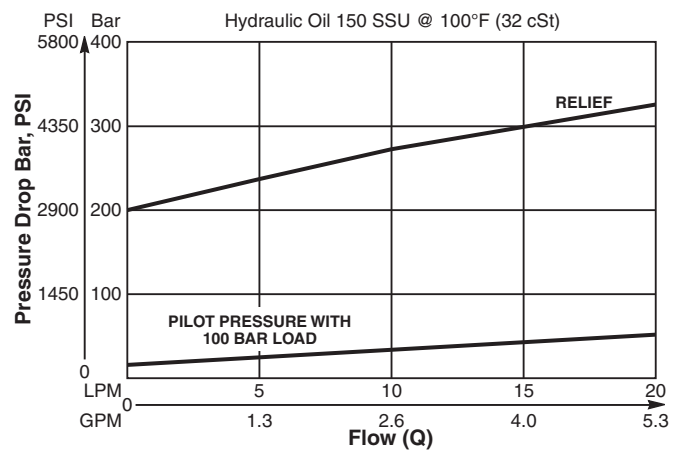

Pressure Drop vs Flow

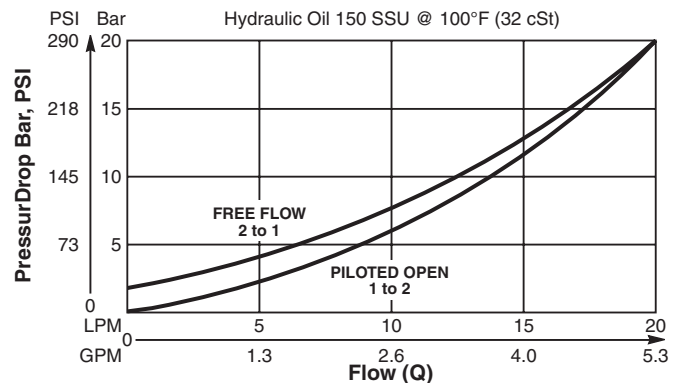

CV
Check Valves

SH
Shuttle Valves

LM
Load/Motor Controls

FC
Flow Controls

PC
Pressure Controls

LE
Logic Elements

DC
Directional Controls

SV
Solenoid Valves

PV
Proportional Valves

CE
Coils & Electronics

BC
Bodies & Cavities

TD
Technical Data

Dimensions Millimeters (Inches)

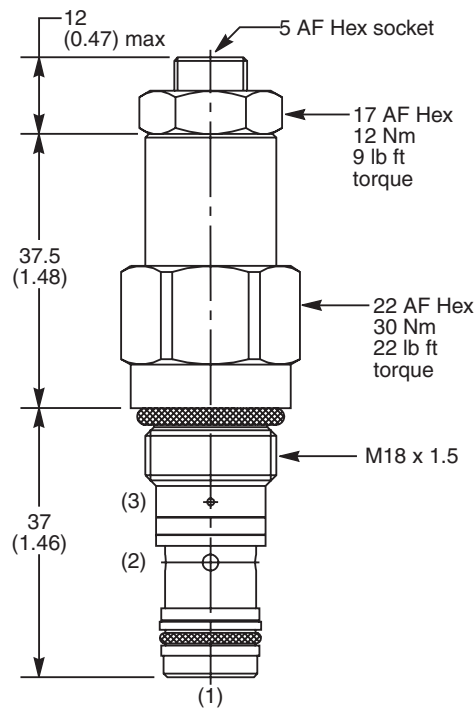

Ordering Information

E6	B	020	Z	N
Load Control Valve	Pilot Ratio		Adjustment Style	Seals

Highlighted represents preferred options that offer the shortest lead times. Other options may be available, but at extended lead times.

Code	Pilot Ratio
B	4.5 : 1

Code	Adjustment Style
Z	Screw Adjust (Standard)

Code	Seals
N	Nitrile

Kit	Part Number
Tamper Resistant Cap	TC1130
Nitrile Seal	SK30087N-1
Fluorocarbon Seal	SK30087V-1

Order Bodies Separately
 See section BC

LB10	318	S
Line Body	Porting	Body Material

Code	Porting
318	3/8" SAE (main) 1/4" SAE (aux)

Code	Body Material
S	Steel / (5000PSI)

*Standard valve is set to crack at 215 Bar (3120 PSI). Valve to be set to 1.3 times maximum load induced pressure.

CV	Check Valves
SH	Shuttle Valves
LM	Load/Motor Controls
FC	Flow Controls
PC	Pressure Controls
LE	Logic Elements
DC	Directional Controls
SV	Solenoid Valves
PV	Proportional Valves
CE	Coils & Electronics
BC	Bodies & Cavities
TD	Technical Data

General Description

Threaded Cartridge Style Counterbalance Valve.
 Pilot assisted, designed for motion control applications
 For additional information see Technical Tips on pages LM2-LM5.

Features

- Spring chamber isolated from system backpressure by double seal, eliminating vent port leakage and need for separate drain line
- Poppet construction for minimal leakage
- Suitable for remote pilot controlled boomlock applications as per ISO8463
- Incorporates direct acting relief valve for overload protection
- Includes reverse check valve within body
- Hardened working parts for maximum durability
- All external parts zinc plated

Specifications

Rated Flow	20 LPM (5.3 GPM)
Pressure	100 - 350 Bar (1450 - 5075 PSI)
Sensitivity: Pressure / Turn	114 Bar (1650 PSI)
Pilot Ratio	15 : 1
Cartridge Material	All parts steel. All operating parts hardened steel.
Operating Temp. Range/Seals	-34°C to +121°C (Nitrile) (-30°F to +250°F) -26°C to +204°C (Fluorocarbon) (-15°F to +400°F)
Fluid Compatibility/Viscosity	Mineral-based or synthetic with lubricating properties at viscosities of 45 to 2000 SSU (6 to 420 cSt)
Filtration	ISO-4406 18/16/13, SAE Class 4
Approx. Weight	0.08 kg (0.18 lbs.)
Cavity	53-1 (See BC Section for more details)

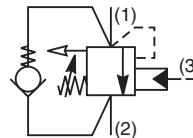
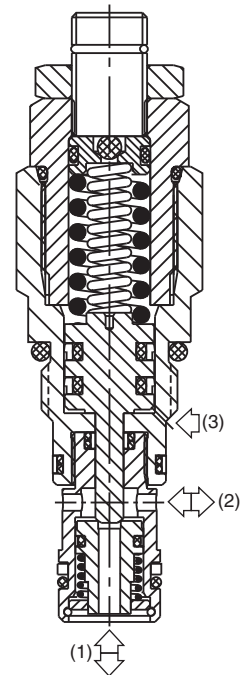

Performance Curves

Relief & Pilot Performance 1 to 2

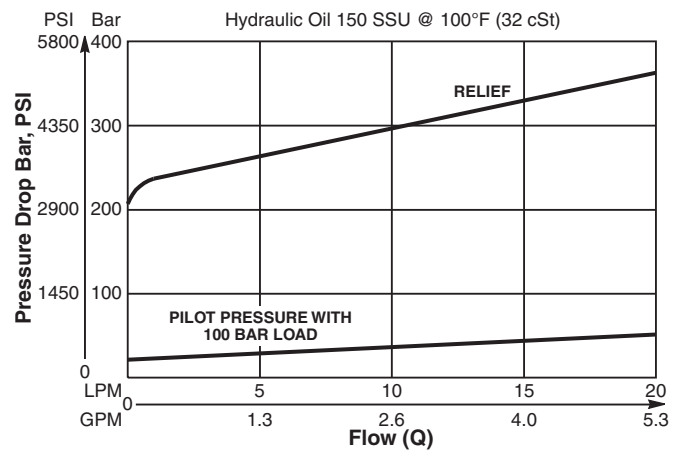

Pressure Drop vs Flow

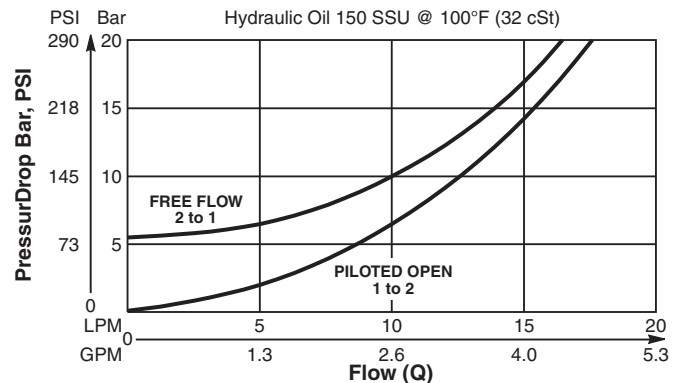

CV
Check Valves

SH
Shuttle Valves

LM
Load/Motor Controls

FC
Flow Controls

PC
Pressure Controls

LE
Logic Elements

DC
Directional Controls

SV
Solenoid Valves

PV
Proportional Valves

CE
Coils & Electronics

BC
Bodies & Cavities

TD
Technical Data

Dimensions Millimeters (Inches)

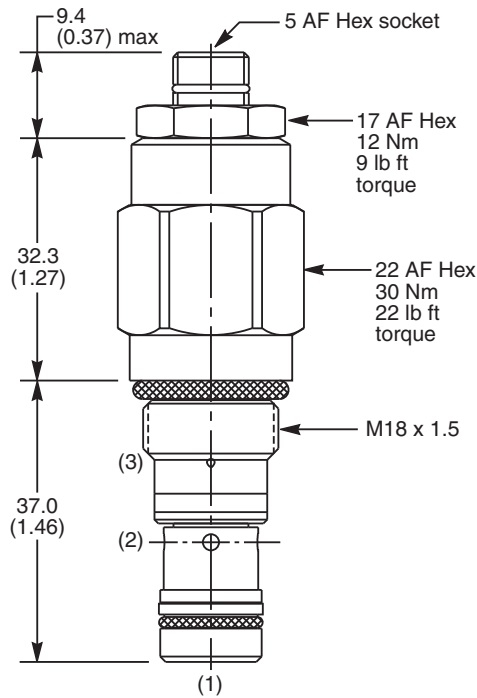

Ordering Information

E6	K	020	Z	N
Load Control Valve	Pilot Ratio		Adjustment Style	Seals

Highlighted represents preferred options that offer the shortest lead times. Other options may be available, but at extended lead times.

Code	Pilot Ratio
K	15:1

Code	Adjustment Style
Z	Screw Adjust (Standard)

Code	Seals
N	Nitrile

Kit	Part Number
Tamper Resistant Cap	TC1130
Nitrile Seal	SK30087N-1
Fluorocarbon Seal	SK30087V-1

Order Bodies Separately
 See section BC

LB10	318	S
Line Body	Porting	Body Material

Code	Porting
318	3/8" SAE (main) 1/4" SAE (aux)

Code	Body Material
S	Steel / (5000PSI)

*Standard valve is set to crack at 215 Bar (3120 PSI). Valve to be set to 1.3 times maximum load induced pressure.

CV
Check Valves
SH
Shuttle Valves
LM
Load/Motor Controls
FC
Flow Controls
PC
Pressure Controls
LE
Logic Elements
DC
Directional Controls
SV
Solenoid Valves
PV
Proportional Valves
CE
Coils & Electronics
BC
Bodies & Cavities
TD
Technical Data

General Description

Threaded Cartridge Style Counterbalance Valve.
 Pilot assisted, designed for motion control applications
 For additional information see Technical Tips on pages LM2-LM5.

Features

- Spring chamber isolated from system backpressure by double seal, eliminating vent port leakage and need for separate drain line
- Poppet construction for minimal leakage
- Incorporates direct acting relief valve for overload protection
- Includes reverse check valve within body, saving space and minimizing installation cost
- Hardened working parts for maximum durability
- All external parts zinc plated

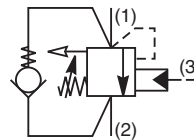
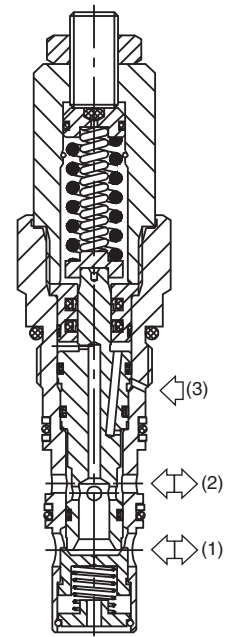
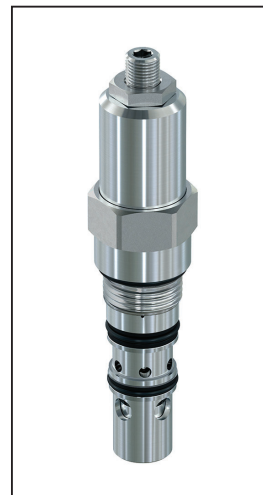

Specifications

Rated Flow	60 LPM (15.9 GPM)
Pressure	50 to 350 Bar (725 to 5075 PSI)
Sensitivity: Pressure / Turn	92 Bar (1335 PSI)
Pilot Ratio	3 : 1
Cartridge Material	All parts steel. All operating parts hardened steel.
Operating Temp. Range/Seals	-34°C to +121°C (Nitrile) (-30°F to +250°F) -26°C to +204°C (Fluorocarbon) (-15°F to +400°F)
Fluid Compatibility/Viscosity	Mineral-based or synthetic with lubricating properties at viscosities of 45 to 2000 SSU (6 to 420 cSt)
Filtration	ISO-4406 18/16/13, SAE Class 4
Approx. Weight	0.33 kg (0.73 lbs.)
Cavity	68-1 (See BC Section for more details)

Performance Curves

Relief & Pilot Performance 1 to 2

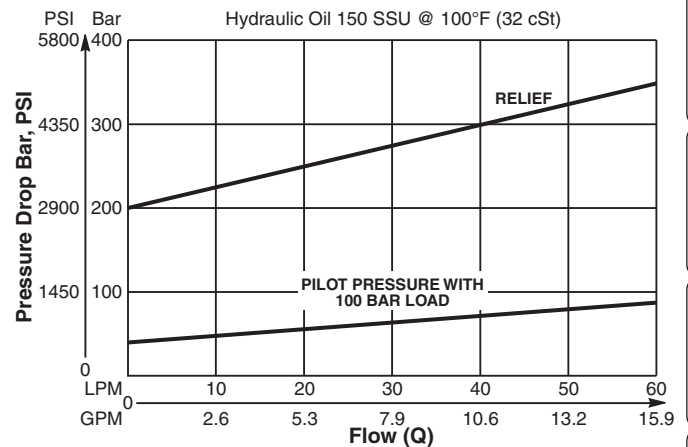

Pressure Drop vs Flow

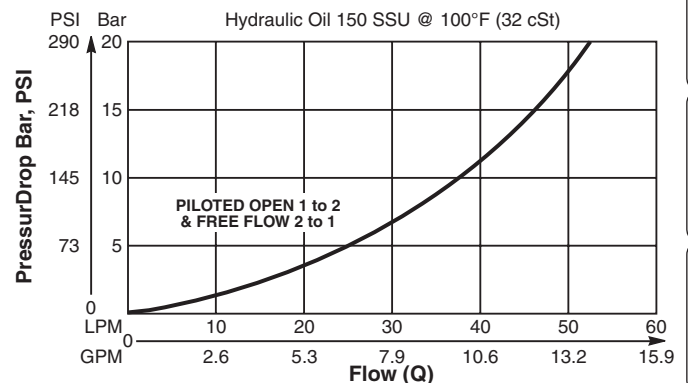

CV
Check Valves

SH
Shuttle Valves

LM
Load/Motor Controls

FC
Flow Controls

PC
Pressure Controls

LE
Logic Elements

DC
Directional Controls

SV
Solenoid Valves

PV
Proportional Valves

CE
Coils & Electronics

BC
Bodies & Cavities

TD
Technical Data

Dimensions Millimeters (Inches)

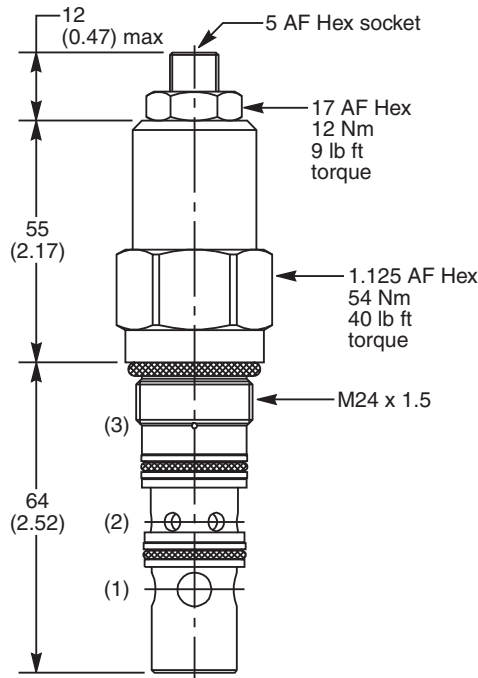

Ordering Information

E6	B	040	Z	N	MK3
Load Control Valve	Pilot Ratio		Adjustment Style	Seals	

Highlighted represents preferred options that offer the shortest lead times. Other options may be available, but at extended lead times.

Code	Pilot Ratio
B	3:1

Code	Adjustment Style
Z	Screw Adjust (Standard)

Code	Seals
N	Nitrile

Kit	Part Number
Tamper Resistant Cap	TC1130
Nitrile Seal	SK30059N-1
Fluorocarbon Seal	SK30059V-1

*Standard valve is set to crack at 215 Bar (3120 PSI). Valve to be set to 1.3 times maximum load induced pressure.

Order Bodies Separately
 See section BC

LB10	253	S
Line Body	Porting	Body Material

Code	Porting
253	1/2" SAE (main) 1/4" SAE (aux)

Code	Body Material
S	Steel



CV	Check Valves
SH	Shuttle Valves
LM	Load/Motor Controls
FC	Flow Controls
PC	Pressure Controls
LE	Logic Elements
DC	Directional Controls
SV	Solenoid Valves
PV	Proportional Valves
CE	Coils & Electronics
BC	Bodies & Cavities
TD	Technical Data

General Description

Threaded Cartridge Style Counterbalance Valve.
 Pilot assisted, designed for motion control applications
 For additional information see Technical Tips on pages LM2-LM5.

Features

- High flow design with extra dampening
- Spring chamber isolated from system backpressure by double seal, eliminating vent port leakage and need for separate drain line
- Poppet construction for minimal leakage
- Incorporates direct acting relief valve for overload protection
- Includes reverse check valve within body, saving space and minimizing installation cost
- Hardened working parts for maximum durability
- All external parts zinc plated

Specifications

Rated Flow	180 LPM (48 GPM)
Pressure	50 to 350 Bar (725 to 5000 PSI)
Sensitivity: Pressure / Turn	50 Bar (725 PSI)
Pilot Ratio	3 : 1
Cartridge Material	All parts steel. All operating parts hardened steel.
Operating Temp. Range/Seals	-34°C to +121°C (Nitrile) (-30°F to +250°F) -26°C to +204°C (Fluorocarbon) (-15°F to +400°F)
Fluid Compatibility/Viscosity	Mineral-based or synthetic with lubricating properties at viscosities of 45 to 2000 SSU (6 to 420 cSt)
Filtration	ISO-4406 18/16/13, SAE Class 4
Approx. Weight	0.53 kg (1.17 lbs.)
Cavity	3C (See BC Section for more details)

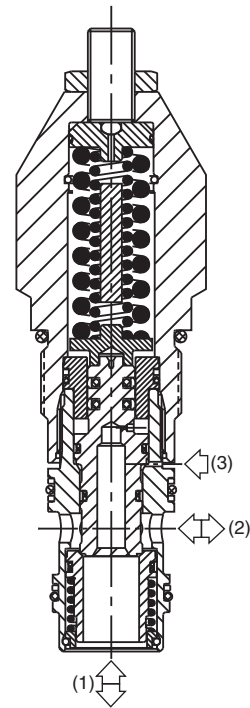
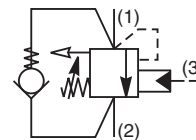
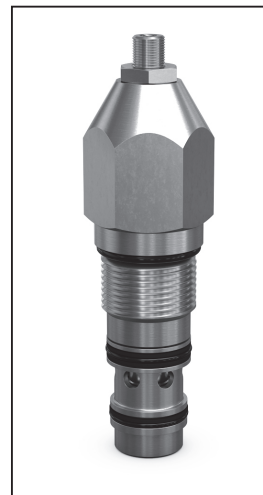

Performance Curves

Relief & Pilot Performance 1 to 2

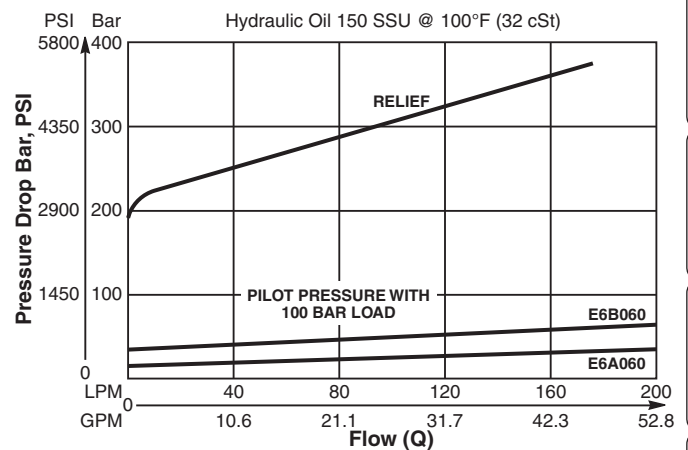

Pressure Drop vs Flow

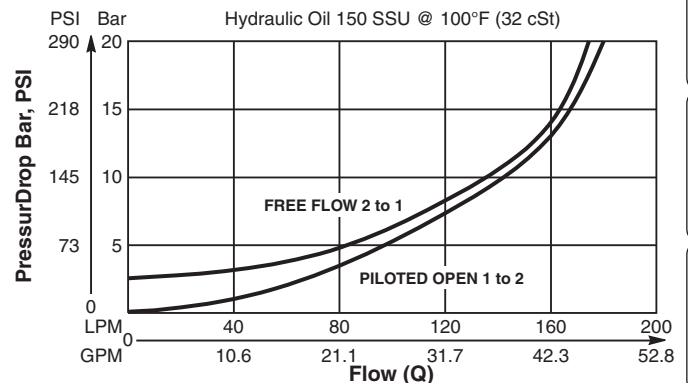

CV
Check Valves

SH
Shuttle Valves

LM
Load/Motor Controls

FC
Flow Controls

PC
Pressure Controls

LE
Logic Elements

DC
Directional Controls

SV
Solenoid Valves

PV
Proportional Valves

CE
Coils & Electronics

BC
Bodies & Cavities

TD
Technical Data

Dimensions Millimeters (Inches)

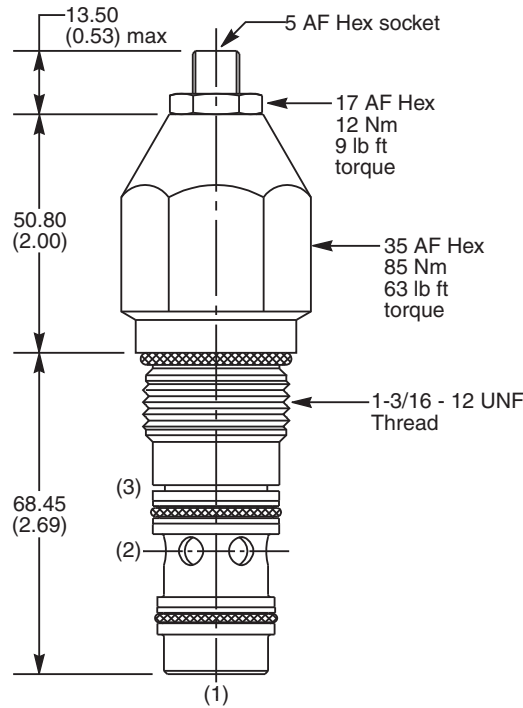

Ordering Information

E6	B	060	Z	N	409
Load Control Valve	Pilot Ratio		Adjustment Style	Seals	Suffix Number

Highlighted represents preferred options that offer the shortest lead times. Other options may be available, but at extended lead times.

Code	Pilot Ratio
B	3:1

Code	Adjustment Style
Z	Screw Adjust (Standard)

Code	Seals
N	Nitrile

Code	Suffix Number
409	High flow design with extra dampening

Order Bodies Separately
 See section BC

LB10	069	S
Line Body	Porting	Body Material

Code	Porting
069	1" SAE (main) 1/4" SAE (aux)



Code	Body Material
S	Steel / (5000PSI)

Kit	Part Number
Tamper Resistant Cap	TC1130
Nitrile Seal	SK30008N-1
Fluorocarbon Seal	SK30008V-1

*Standard valve is set to crack at 215 Bar (3120 PSI). Valve to be set to 1.3 times maximum load induced pressure.

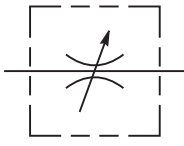
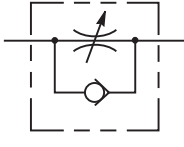
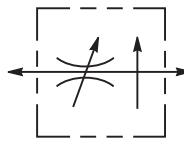
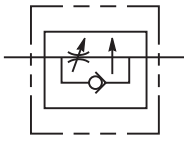
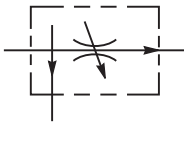

CV	Check Valves
SH	Shuttle Valves
LM	Load/Motor Controls
FC	Flow Controls
PC	Pressure Controls
LE	Logic Elements
DC	Directional Controls
SV	Solenoid Valves
PV	Proportional Valves
CE	Coils & Electronics
BC	Bodies & Cavities
TD	Technical Data

SERIES	CAVITY	DESCRIPTION	FLOW LPM/GPM	PRESSURE BAR/PSI	PAGE NO.
Technical Tips.....					FC2-FC5
NEEDLE VALVES					
	NVH081	C08-2 Needle Valve, Cartridge Type	38/10	380/5500	FC6-FC7
	NVH101	C10-2 Needle Valve, Cartridge Type	60/16	380/5500	FC8-FC9
	FV101	C10-2 Needle Valve with Reverse Check, to 2 Free Flow	45/12	210/3000	FC10-FC11
	FV102	C10-2 Needle Valve with Reverse Check, 1 to 2 Free Flow	23/6	210/3000	FC10-FC11
PRESSURE COMPENSATED FLOW CONTROLS					
	J02E2	C08-2 Restrictive Flow Control, Adjustable	20/5.3	420/6000	FC12-FC13
	J04E2	C10-2 Restrictive Flow Control, Adjustable	40/10	420/6000	FC14-FC15
	FA101	C10-2 Restrictive Flow Control, Reverse Check, Adjustable	21/5.5	210/3000	FC16-FC17
	FC101	C10-2 Restrictive Flow Control, Reverse Check, Tuneable	56/15	210/3000	FC18-FC19
PRESSURE COMPENSATED PRIORITY FLOW CONTROLS					
	J02D3	C08-3 Priority Type, with Bypass	15/4	420/6000	FC20-FC21
	J04D3	C10-3 Priority Type, with Bypass	70/18	420/6000	FC22-FC23
	J1A125	3A Priority Type, with Bypass	150/40	420/6000	FC24-FC25
FLOW DIVIDERS/COMBINERS					
	L04A3	C10-4 Flow Divider/Combiner	60/16	420/6000	FC26-FC27
	L06A3	C16-4 Flow Divider/Combiner	180/47	420/6000	FC28-FC29

CV
Check Valves

SH
Shuttle Valves

LM
Load/Motor Controls

FC
Flow Controls

PC
Pressure Controls

LE
Logic Elements

DC
Directional Controls

SV
Solenoid Valves

PV
Proportional Valves

CE
Coils & Electronics

BC
Bodies & Cavities

TD
Technical Data

INTRODUCTION

This technical tips section is designed to help familiarize you with the Parker line of Flow Control Valves. In this section we present common options available as well as a brief synopsis of the operation and applications of the various product offered in this section. The intent of this section is to help you in selecting the best products for your application.

COMMON OPTIONS

As you will see, Parker offers a variety of Flow Control products. As such, some of the options mentioned below may not be available on all valve models. Consult the model coding and dimensions of each valve for specifics. Here are some of the common options available.

Adjustment Types: Parker offers four primary types of adjustments for most of the flow control products. Samples of these types are shown below. Please note all options may not be available for all valves. Consult the individual catalog pages for more details.

Screw Adjustment - Valve can be adjusted with an allen wrench. Lock nut included to maintain desired setting after adjustment. This is the most common adjustment option available on most Parker products.

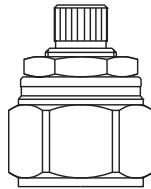

Knob Adjustment - An aluminum knob is added to the standard screw adjustment. A lock knob is provided to help maintain the desired setting after adjustment. Parker offers knob conversion kits for most flow control valves. For kit numbers consult the individual valve pages.

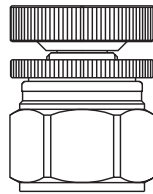

Fixed Style - In most cases, the Fixed Style product is a screw adjustable product with a steel collet threaded over the adjustment. These valves are preset at the factory. Should the valve need to be adjusted, the star washer and aluminum plate can be removed from the top of the assembly exposing the adjustment.

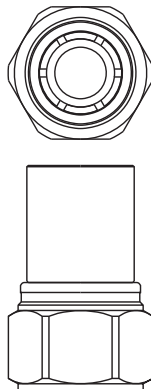

Tamper Resistant - The tamper resistant option is a screw adjustable valve with a steel cap installed to conceal the adjustment. The cap is designed so the internal edges clamp into the groove of the valve adapter. Once the cap is installed, it cannot be removed without damaging the cap and the valve. When a valve is ordered with the tamper resistant option, it will be preset at the factory, and the cap will be included in a separate plastic bag to allow for fine tuning at the customer site. Parker offers tamper resistant cap conversion kits for most flow control valves. For kit numbers consult the individual valve pages.

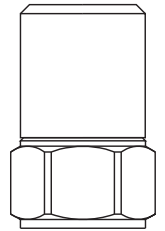

Seals: Valves feature either a 4301 Polyurethane “D”-Ring. The “D”-Ring eliminates the need for backup rings. The majority of the products are also available in Nitrile or Fluorocarbon seals. Contact factory for availability. You should match the seal compatibility to the temperature and fluid being used in your application.

Fine Meter Options: Fine meter needles are offered on some needle valve series. When this option is specified, the standard needle is replaced by a slotted needle. The slotted needle restricts substantially more flow giving you finer control in the small flow ranges. Obviously, the maximum flow capacity of the needle valve is decreased with the fine meter option.

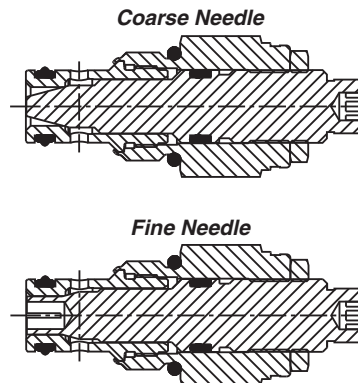

PRODUCT TYPES / APPLICATIONS

Needle Valve

Needle valves provide uncompensated adjustable flow control of a desired function. They are ideal for applications where general control of hydraulic flow is needed, like in a bleed off circuit.

When used with a compensator spool, a pressure compensated system can be obtained.

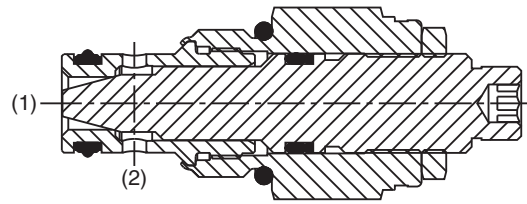
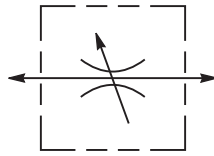

OPERATION - The valve acts as a fixed orifice in a hydraulic circuit. The effective size of the orifice increases as the tapered needle is opened. Shutoff is provided when fully closed. While a needle valve will meter flow regardless of the flow path, flow from port 2 to 1 is preferred. When you flow in the reverse direction (1 to 2), pressure forces work on the nose of the needle in an effort to drive it off of its seat. As such, all leakage conditions found in the catalog are based on flow from side to nose (port 2 to port 1). In addition, the adjustment will be harder to turn due to the added force.

Needle with a Reverse Check

Needle valves with reverse check functions are sometimes also referred to as flow control valves. As the name implies, these valves provide uncompensated adjustable speed control in one direction and allow free flow in the opposite direction. When used with a compensator spool, a pressure compensated system can be obtained.

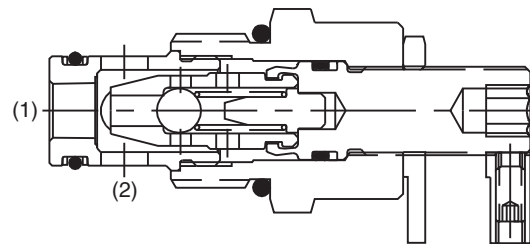
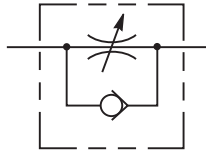

OPERATION - With flow entering the side of the cartridge (port 2), the needle acts as a fixed orifice. The effective size of this orifice is increased as the needle is opened controlling the output flow to port 1. With flow entering the nose (port 1), the check ball inside the needle is unseated allowing free flow to port 2.

P.C. Flow Regulator

Pressure compensated flow regulators maintain a regulated flow regardless of changes in load or inlet pressure. They are commonly used to accurately control an actuator function. They can be used in meter-in or meter-out applications.

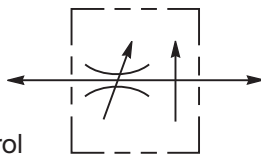

OPERATION - The valve consists of a control orifice within a normally open, spring biased compensator spool. Flow through the control orifice produces a pressure drop across the compensator spool. When inlet flow exceeds the flow setting of the valve, the force produced by the pressure differential across the spool exceeds the spring force and shifts the compensator spool to throttle or restrict flow; thus maintaining consistent flow through the valve. In the reverse direction, flow is metered, but not pressure compensated.

CV
Check Valves

SH
Shuttle Valves

LM
Load/Motor Controls

FC
Flow Controls

PC
Pressure Controls

LE
Logic Elements

DC
Directional Controls

SV
Solenoid Valves

PV
Proportional Valves

CE
Coils & Electronics

BC
Bodies & Cavities

TD
Technical Data

P.C. Flow Control

Pressure compensated flow controls are pressure compensated regulators with a reverse flow check valve. They provide constant regulated flow in the one direction regardless of changes in load pressure. Flow in the reverse direction is non-regulated, free flow. They can be used in meter-in or meter-out applications.

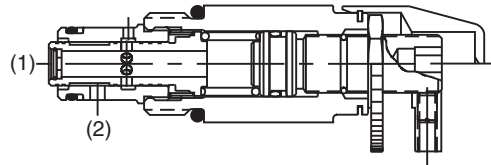
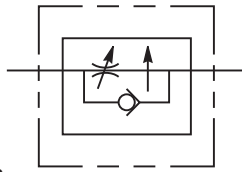

Adjustable Flow Controls

Most adjustable pressure compensated flow controls have a limited adjustment range. You will see in our catalog that we use the term “tuneable” for the FR101 and FC101 valves.

This means they are only adjustable within a pre-set range. The FA101, J02E2, J04E2 and J04C2 are fully adjustable. Keep this adjustment capability in mind when you select a flow control.

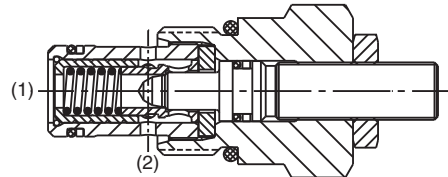
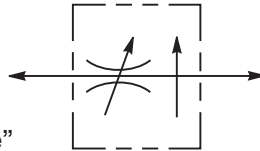

OPERATION - When flow enters the nose (port 1) of the cartridge, it passes through a control orifice. This control orifice creates a pressure differential across the regulating spool. As the inlet flow increases, the pressure differential across the regulating spool increases, allowing the regulating spool to overcome its spring force and begin to shift. As it shifts, it throttles to maintain a constant flow. When used in conjunction with a fixed displacement pump, a relief valve between pump and valve is needed. Full flow is allowed in the reverse direction (port 2 to 1).

Priority Style P.C. Flow Regulator

Priority style pressure compensator regulators maintain constant priority flow to one leg of the circuit regardless of changes in load or inlet pressure. Once this priority flow requirement is satisfied, the excess flow is diverted and can be used in another leg of the circuit. These valves are usually used in meter-in applications.

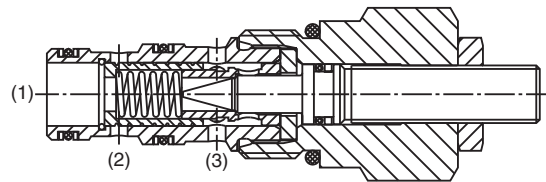
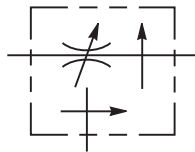

OPERATION - The valve consists of a control orifice within a spring biased compensator spool. The priority port is normally open while the bypass port is normally closed. As flow enters the inlet of the cartridge and passes through the control orifice, a pressure differential is created across the compensator spool. When the inlet flow exceeds the setting of the valve, the force produced by this pressure differential exceeds the spring force and shifts the compensator spool; opening up the bypass port, and bypassing the excess flow. If load pressure at the bypass port is greater than the load pressure at the priority port, the compensator spool will further shift restricting the priority flow to that of the valve setting. **Caution:** If the priority line is blocked so that no flow can pass through the control orifice, the compensator spool will shift, blocking the bypass port and allowing inlet pressure to go to full system relief pressure. These valves do not provide a pressure relieving function, so it is common to place an external relief valve downstream of port 3 to prevent a no flow condition.

CV	Check Valves
SH	Shuttle Valves
LM	Load/Motor Controls
FC	Flow Controls
PC	Pressure Controls
LE	Logic Elements
DC	Directional Controls
SV	Solenoid Valves
PV	Proportional Valves
CE	Coils & Electronics
BC	Bodies & Cavities
TD	Technical Data

Flow Divider / Combiner

Flow divider / combiner valves are used to proportion the flow from a single source into two actuators. In the reverse mode, the valve takes the flow from the two sources and combines it into one flow.

When attempting to synchronize two cylinders

with a flow/divider combiner valve, please consider that the flow accuracy is +10%.

A crossover relief can be used to help re-synchronize the cylinders by bottoming them out after several cycles.

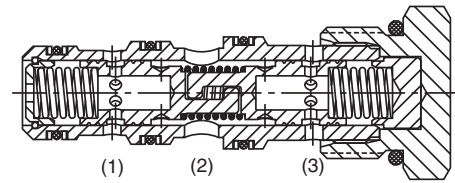
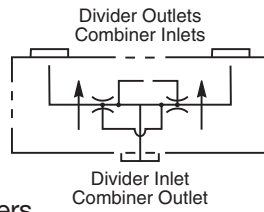

OPERATION - When flow enters the divider inlet port, it will pass through orifices in each of the interconnected spools. The flow passing through the orifices creates a pressure drop which pulls the two spools away from each other. The flow then passes to the two divider outlet ports. The division of flow (i.e. 50-50, 60-40, 66-33, etc.) is determined by the orifice sizes in the two spools. When flow is being combined, it enters the valve through two combiner inlets. The pressure drop across the orifices pulls the two spools together. The combined flow then passes through the combiner outlet.

CV	Check Valves
SH	Shuttle Valves
LM	Load/Motor Controls
FC	Flow Controls
PC	Pressure Controls
LE	Logic Elements
DC	Directional Controls
SV	Solenoid Valves
PV	Proportional Valves
CE	Coils & Electronics
BC	Bodies & Cavities
TD	Technical Data

General Description

Cartridge Style Needle Valve.
 For additional information see Technical Tips on pages FC2-FC5.

Features

- Hardened, precision ground parts for durability
- Compact size for reduced space requirements
- Fine adjustment needle option available for precise adjustment
- Polyurethane “D”-Ring eliminates backup rings and prevents hydrolysis
- Valve meters flow in either direction, but (2 to 1) is the preferred direction for lowest leakage at shut off
- All external parts zinc plated

Specifications

Rated Flow	37.9 LPM (10 GPM)
Maximum Inlet Pressure	380 Bar (5500 PSI)
Cartridge Material	All parts steel. All operating parts hardened steel.
Operating Temp. Range/Seals	-37°C to +93°C (“D”-Ring) (-35°F to +200°F) -34°C to +121°C (Nitrile) (-30°F to +250°F) -26°C to +204°C (Fluorocarbon) (-15°F to +400°F)
Fluid Compatibility/ Viscosity	Mineral-based or synthetic with lubricating properties at viscosities of 45 to 2000 SSU (6 to 420 cSt)
Filtration	ISO-4406 18/16/13, SAE Class 4
Approx. Weight	0.10 kg (0.20 lbs.)
Cavity	C08-2 (See BC Section for more details)

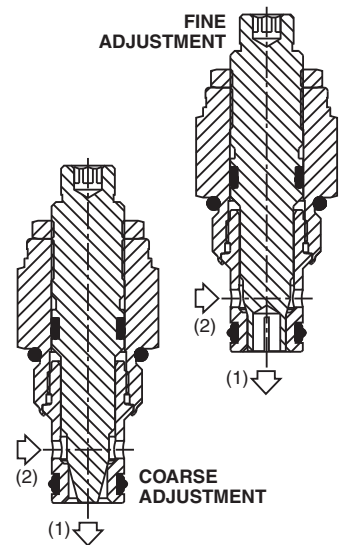
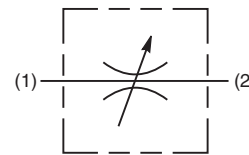

Performance Curves

Flow vs. Inlet Pressure (Through cartridge only)

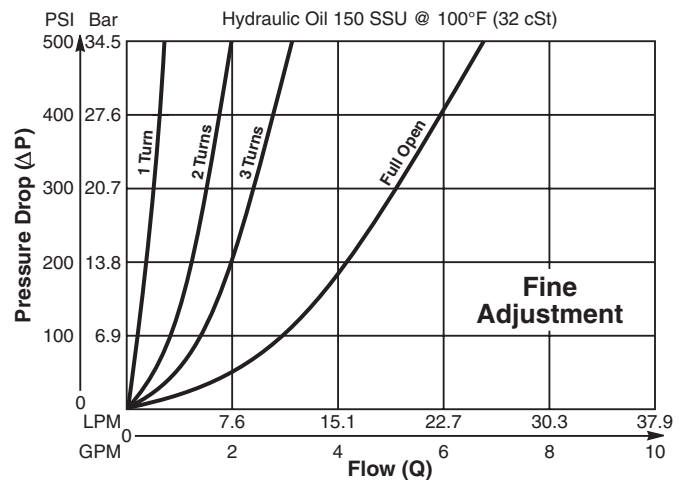
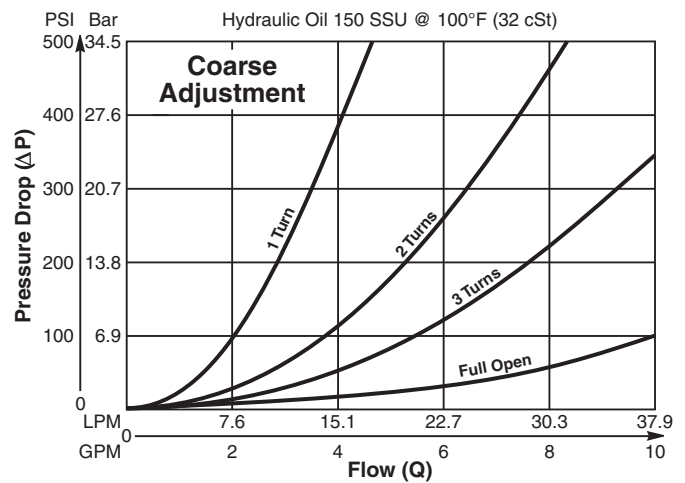

CV
Check Valves
SH
Shuttle Valves
LM
Load/Motor Controls
FC
Flow Controls
PC
Pressure Controls
LE
Logic Elements
DC
Directional Controls
SV
Solenoid Valves
PV
Proportional Valves
CE
Coils & Electronics
BC
Bodies & Cavities
TD
Technical Data

Dimensions Millimeters (Inches)

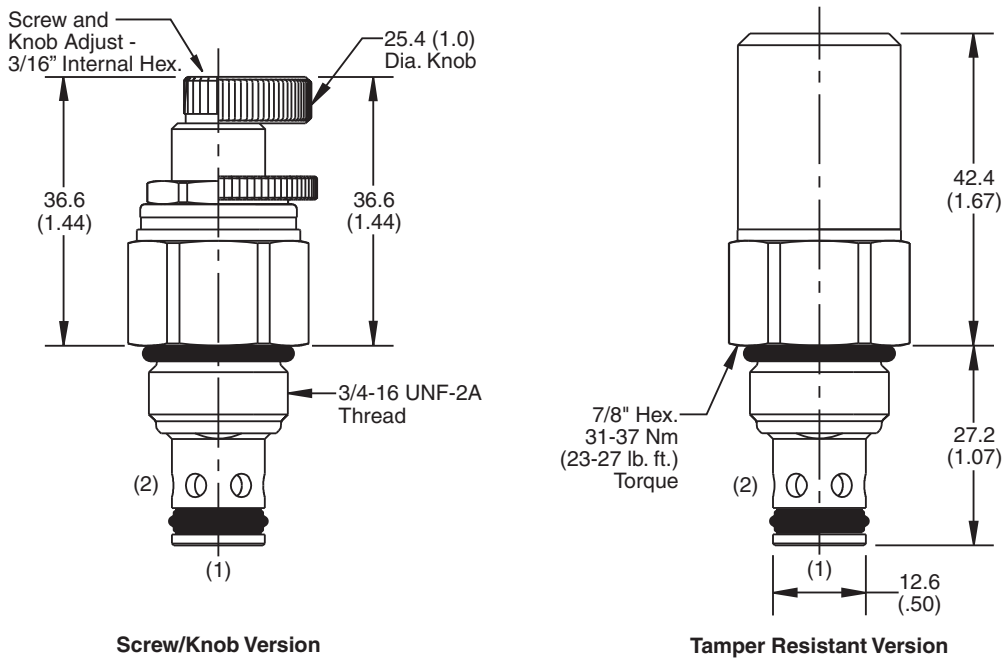

Ordering Information

NVH081 **S**
 08 Size Needle Valve Flow Needle Adjustment Style

Highlighted represents preferred options that offer the shortest lead times. Other options may be available, but at extended lead times.

Code	Flow Needle
Omit	Coarse
F	Fine

Code	Adjustment Style
S	Screw Adjust

Code	Seals
Omit	"D"-Ring

Kit	Part Number
Knob	717784-10
Tamper Resistant Cap	717943
D-Ring Seal	SK08-2
Nitrile Seal	SK08-2
Fluorocarbon Seal	SK08-2V

Order Bodies Separately
 See section BC

B08 - **2** - **6T**
 08 size 2-Way Cavity Port Size

Code	Porting / Body Material
6T	SAE-6 / Steel (5000 PSI)

CV
Check Valves

SH
Shuttle Valves

LM
Load/Motor Controls

FC
Flow Controls

PC
Pressure Controls

LE
Logic Elements

DC
Directional Controls

SV
Solenoid Valves

PV
Proportional Valves

CE
Coils & Electronics

BC
Bodies & Cavities

TD
Technical Data

General Description

Cartridge Style Needle Valve.
 For additional information see Technical Tips on pages FC2-FC5.

Features

- Hardened, precision ground parts for durability
- Compact size for reduced space requirements
- Fine adjustment needle option available for precise adjustment
- Polyurethane “D”-Ring eliminates backup rings and prevents hydrolysis
- Valve meters flow in either direction, but (2 to 1) is the preferred direction for lowest leakage at shut off
- All external parts zinc plated

Specifications

Rated Flow	60 LPM (16 GPM)
Maximum Inlet Pressure	380 Bar (5500 PSI)
Cartridge Material	All parts steel. All operating parts hardened steel.
Operating Temp. Range/Seals	-37°C to +93°C (“D”-Ring) (-35°F to +200°F) -34°C to +121°C (Nitrile) (-30°F to +250°F) -26°C to +204°C (Fluorocarbon) (-15°F to +400°F)
Fluid Compatibility/ Viscosity	Mineral-based or synthetic with lubricating properties at viscosities of 45 to 2000 SSU (6 to 420 cSt)
Filtration	ISO-4406 18/16/13, SAE Class 4
Approx. Weight	0.18 kg (0.40 lbs.)
Cavity	C10-2 (See BC Section for more details)

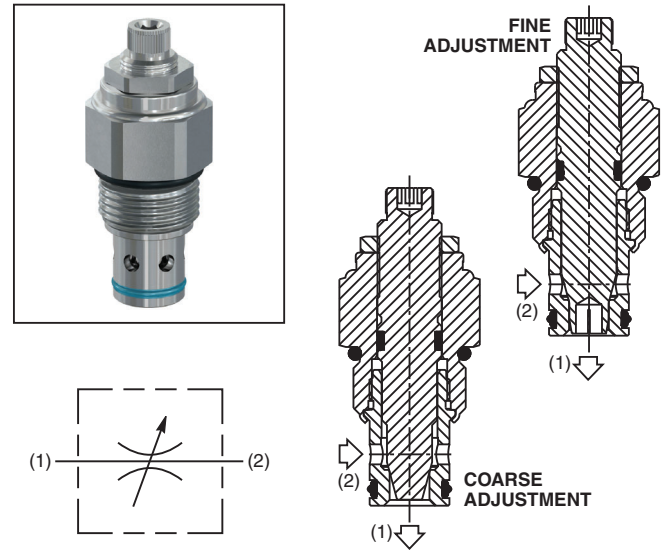

Performance Curves

Flow vs. Inlet Pressure (Through cartridge only)

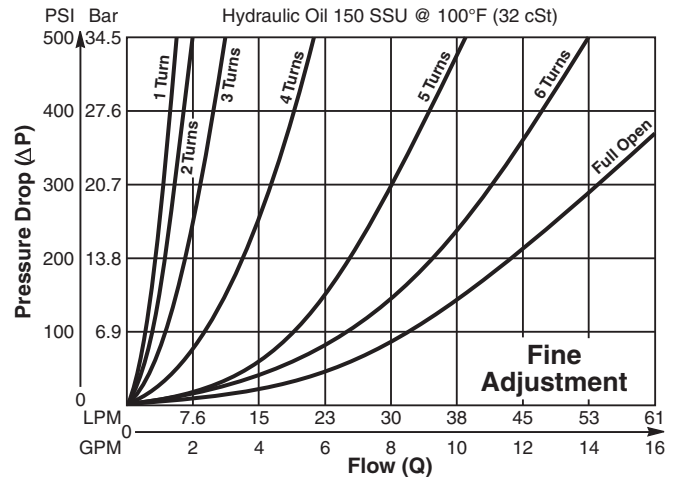
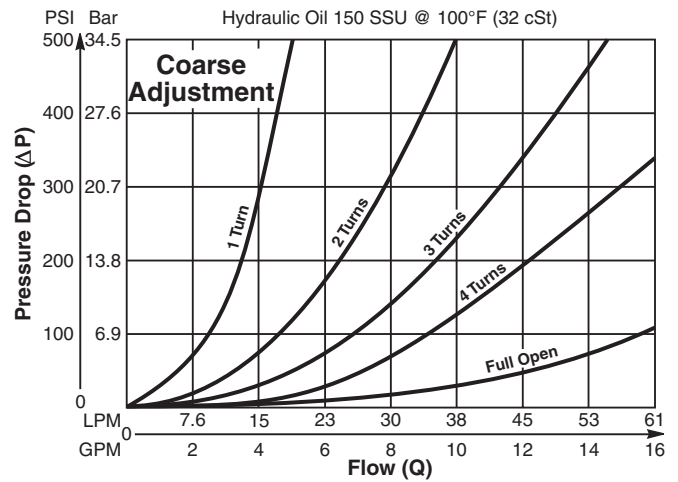

CV
Check Valves
SH
Shuttle Valves
LM
Load/Motor Controls
FC
Flow Controls
PC
Pressure Controls
LE
Logic Elements
DC
Directional Controls
SV
Solenoid Valves
PV
Proportional Valves
CE
Coils & Electronics
BC
Bodies & Cavities
TD
Technical Data

Dimensions Millimeters (Inches)

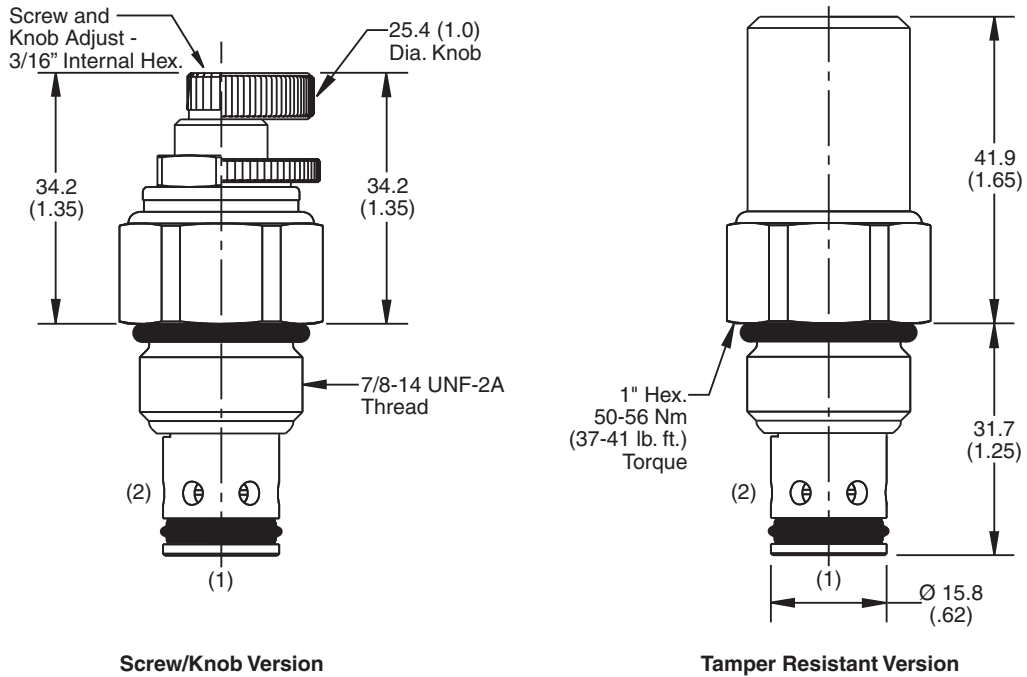

Screw/Knob Version

Tamper Resistant Version

Ordering Information

NVH101 **S**
 10 Size Needle Valve Flow Needle Adjustment Style

Highlighted represents preferred options that offer the shortest lead times. Other options may be available, but at extended lead times.

Code	Flow Needle
Omit	Coarse
F	Fine

Code	Adjustment Style
S	Screw Adjust

Code	Seals
Omit	"D"-Ring

Kit	Part Number
Knob	717784-10
Tamper Resistant Cap	717943
D-Ring Seal	SK10-2
Nitrile Seal	SK10-2
Fluorocarbon Seal	SK10-2V

*Order Bodies Separately
 See section BC*

B10 - **2** - **8T**
 10 size 2-Way Cavity Port Size

Code	Porting / Body Material
8T	SAE-8 / Steel (5000 PSI)

CV
Check Valves

SH
Shuttle Valves

LM
Load/Motor Controls

FC
Flow Controls

PC
Pressure Controls

LE
Logic Elements

DC
Directional Controls

SV
Solenoid Valves

PV
Proportional Valves

CE
Coils & Electronics

BC
Bodies & Cavities

TD
Technical Data

General Description

Needle Valve with a Reverse Check. Also known as a Flow Control Valve.
 For additional information see Technical Tips on pages FC2-FC5.

Features

- Hardened, precision ground parts for durability
- Compact size for reduced space requirements
- Fine thread needle option available for precise adjustment
- All external parts zinc plated

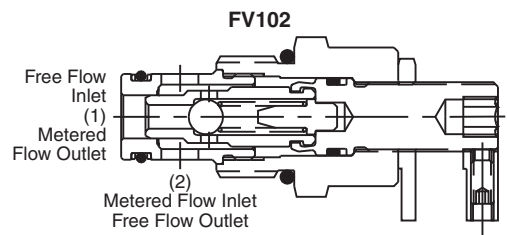
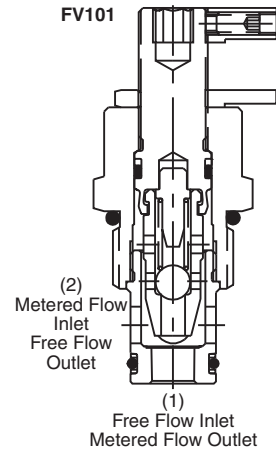
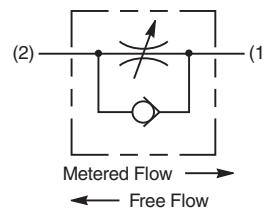
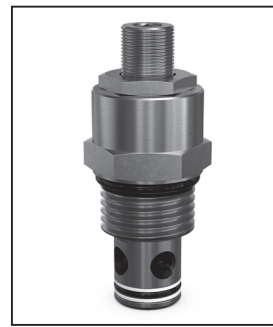

Specifications

Rated Flow	FV101 45 LPM (12 GPM) FV102 23 LPM (6 GPM)
Maximum Inlet Pressure	210 Bar (3000 PSI)
Cartridge Material	All parts steel. All operating parts hardened steel.
Operating Temp. Range/Seals	-34°C to +121°C (Nitrile) (-30°F to +250°F) -26°C to +204°C (Fluorocarbon) (-15°F to +400°F)
Fluid Compatibility/Viscosity	Mineral-based or synthetic with lubricating properties at viscosities of 45 to 2000 SSU (6 to 420 cSt)
Filtration	ISO-4406 18/16/13, SAE Class 4
Approx. Weight	0.23 kg (0.50 lbs.)
Cavity	C10-2 (See BC Section for more details)

Dimensions Millimeters (Inches)

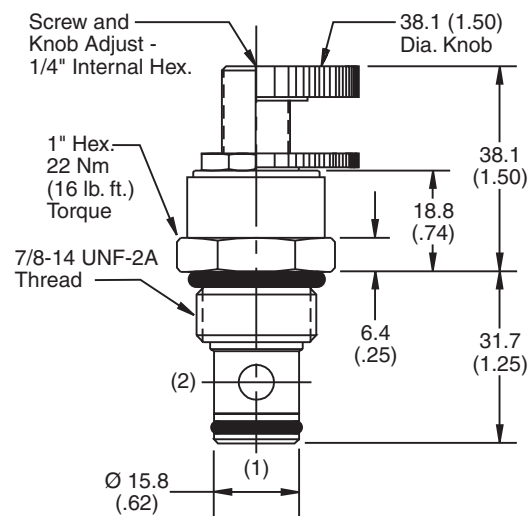

CV
Check Valves
SH
Shuttle Valves
LM
Load/Motor Controls
FC
Flow Controls
PC
Pressure Controls
LE
Logic Elements
DC
Directional Controls
SV
Solenoid Valves
PV
Proportional Valves
CE
Coils & Electronics
BC
Bodies & Cavities
TD
Technical Data

Performance Curves

Metered Flow vs. Pressure Drop (Through cartridge only)

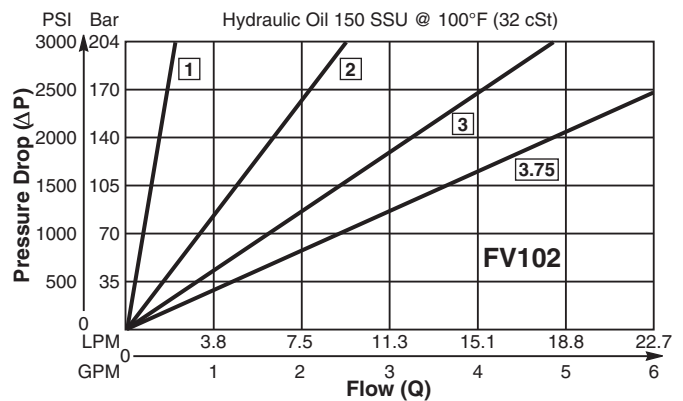
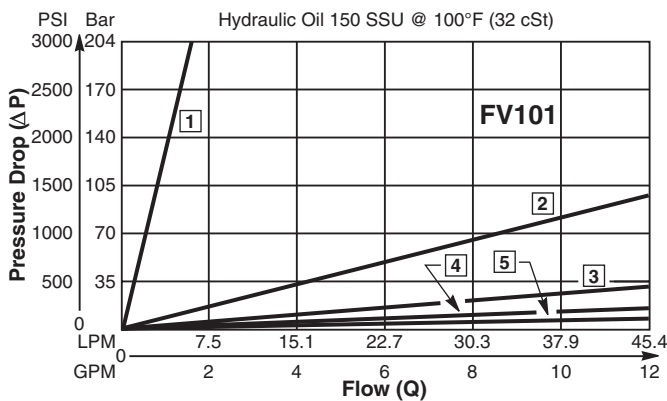

☐ = No. of Turns CCW From Fully Closed.

The number on each curve indicates the number of complete turns of the knob or screw adjustment from fully closed. When the metered flow is 22.5 LPM (6 GPM) and the adjustment is two complete turns from closed, the pressure drop will be 13.8 Bar (200 PSI). When the metered flow is 22.5 LPM (6 GPM) and the adjustment is five complete turns from closed, the pressure drop will be 3.5 Bar (50 PSI).

☐ = No. of Turns CCW From Fully Closed.

The number on each curve indicates the number of complete turns of the knob or screw adjustment from fully closed (non-metered flow). When the metered flow is 7.5 LPM (2 GPM) and the adjustment is two complete turns from closed, the pressure drop will be 156.9 Bar (2275 PSI). When the metered flow is 7.5 LPM (2 GPM) and the adjustment is 3.75 turns from closed, the pressure drop will be 56.6 Bar (820 PSI).

Ordering Information

FV10 **S**
 10 Size Style Adjustment
 Flow Control Valve Style Style

Highlighted represents preferred options that offer the shortest lead times. Other options may be available, but at extended lead times.

Code	Style
1	Coarse Flow
2	Fine Flow

Code	Adjustment Style
S	Screw Adjust

Code	Seals
Omit	Nitrile

Kit	Part Number
Knob	840208K
Nitrile Seal	SK10-2
Fluorocarbon Seal	SK10-2V

Order Bodies Separately
 See section BC

B10 — **2** — **8T**
 10 size 2-Way Cavity Port Size

Code	Porting / Body Material
8T	SAE-8 / Steel (5000 PSI)

CV
Check Valves

SH
Shuttle Valves

LM
Load/Motor Controls

FC
Flow Controls

PC
Pressure Controls

LE
Logic Elements

DC
Directional Controls

SV
Solenoid Valves

PV
Proportional Valves

CE
Coils & Electronics

BC
Bodies & Cavities

TD
Technical Data

General Description

Restrictive Style, Pressure Compensated Flow Control Valve.

For additional information see Technical Tips on pages FC2-FC5.

Features

- Minimal flow change with pressure variation
- Reverse flow function
- Full adjustment from 1-20 LPM (0.3-5.3 GPM)
- Hardened working parts for maximum durability
- All external parts zinc plated

Specifications

Rated Flow	20 LPM (5.3 GPM)
Maximum Inlet Pressure	420 Bar (6000 PSI)
Cartridge Material	All parts steel. All operating parts hardened steel.
Operating Temp. Range/Seals	-34°C to +121°C (Nitrile) (-30°F to +250°F) -26°C to +204°C (Fluorocarbon) (-15°F to +400°F)
Fluid Compatibility/Viscosity	Mineral-based or synthetic with lubricating properties at viscosities of 45 to 2000 SSU (6 to 420 cSt)
Filtration	ISO-4406 18/16/13, SAE Class 4
Approx. Weight	0.13 kg (0.29 lbs.)
Cavity	C08-2 (See BC Section for more details)

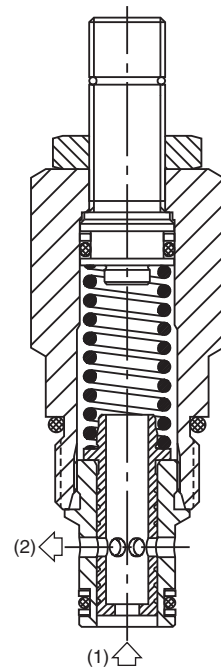
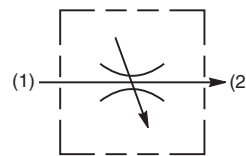

Performance Curves

Flow vs. Inlet Pressure (Through cartridge only)

Flow Regulating Performance

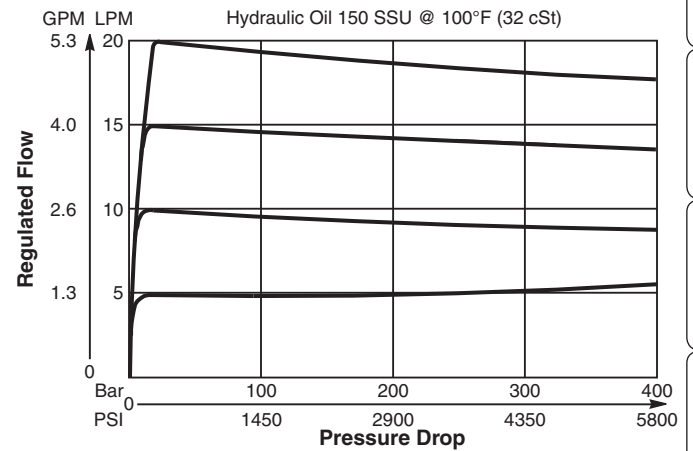

Reverse Flow Pressure Drop vs. Flow

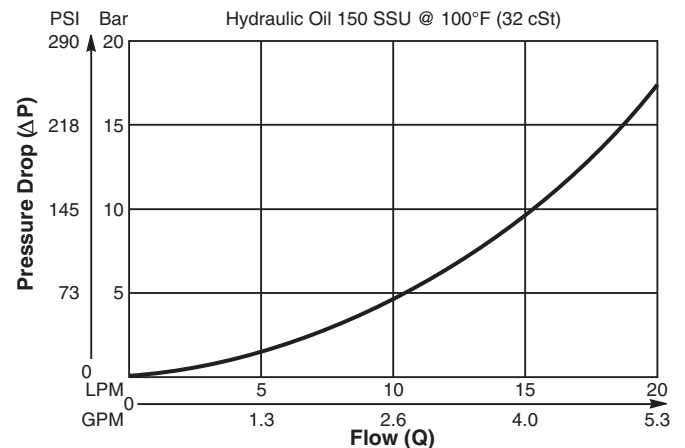

CV
Check Valves
SH
Shuttle Valves
LM
Load/Motor Controls
FC
Flow Controls
PC
Pressure Controls
LE
Logic Elements
DC
Directional Controls
SV
Solenoid Valves
PV
Proportional Valves
CE
Coils & Electronics
BC
Bodies & Cavities
TD
Technical Data

Dimensions Millimeters (Inches)

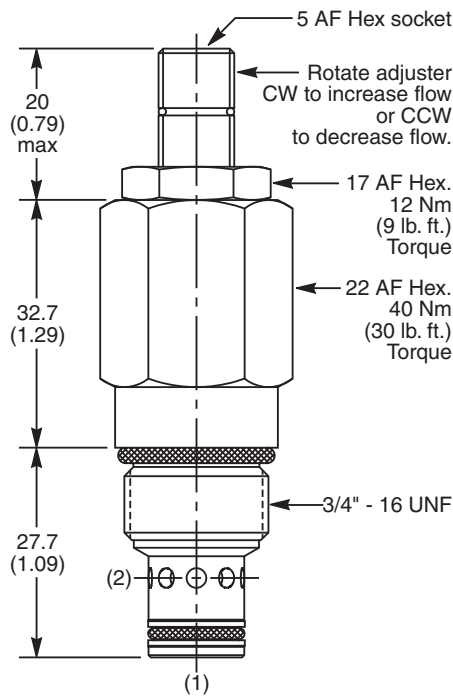

Ordering Information

J02E2	Z	N
08 Size Pressure Compensated Flow Control Valve	Adjustment Style	Seals

Highlighted represents preferred options that offer the shortest lead times. Other options may be available, but at extended lead times.

Code	Adjustment Style
Z	Screw Adjust

Code	Seals
N	Nitrile

Standard valve has a flow setting of 10 LPM.

*Order Bodies Separately
 See section BC*

B08	—	2	—	6T
08 size		2-Way Cavity		Port Size

Code	Porting / Body Material
6T	SAE-6 / Steel (5000 PSI)

Kit	Part Number
Knob	ASV014975
Tamper Resistant Cap	TC1130
Nitrile Seal	SK30501N-1
Fluorocarbon Seal	SK30501V-1

CV	Check Valves
SH	Shuttle Valves
LM	Load/Motor Controls
FC	Flow Controls
PC	Pressure Controls
LE	Logic Elements
DC	Directional Controls
SV	Solenoid Valves
PV	Proportional Valves
CE	Coils & Electronics
BC	Bodies & Cavities
TD	Technical Data

General Description

Restrictive Style, Pressure Compensated Flow Control Valve.

For additional information see Technical Tips on pages FC2-FC5.

Features

- Minimal flow change with pressure variation
- Reverse flow function
- Full adjustment from 1-40 LPM (0.3-10.6 GPM)
- Hardened working parts for maximum durability
- All external parts zinc plated

Specifications

Rated Flow	40 LPM (10.6 GPM)
Maximum Inlet Pressure	420 Bar (6000 PSI)
Cartridge Material	All parts steel. All operating parts hardened steel.
Operating Temp. Range/Seals	-34°C to +121°C (Nitrile) (-30°F to +250°F) -26°C to +204°C (Fluorocarbon) (-15°F to +400°F)
Fluid Compatibility/Viscosity	Mineral-based or synthetic with lubricating properties at viscosities of 45 to 2000 SSU (6 to 420 cSt)
Filtration	ISO-4406 18/16/13, SAE Class 4
Approx. Weight	0.20 kg (0.44 lbs.)
Cavity	C10-2 (See BC Section for more details)

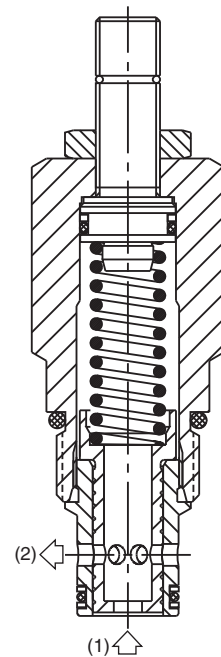
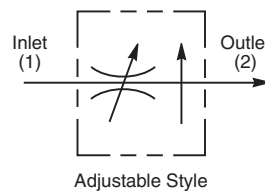

Performance Curves

Flow vs. Inlet Pressure (Through cartridge only)

Flow Regulating Performance

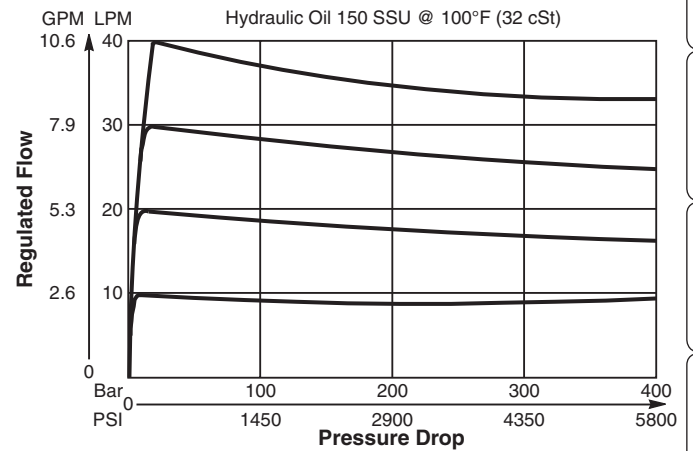

Reverse Flow Pressure Drop vs. Flow

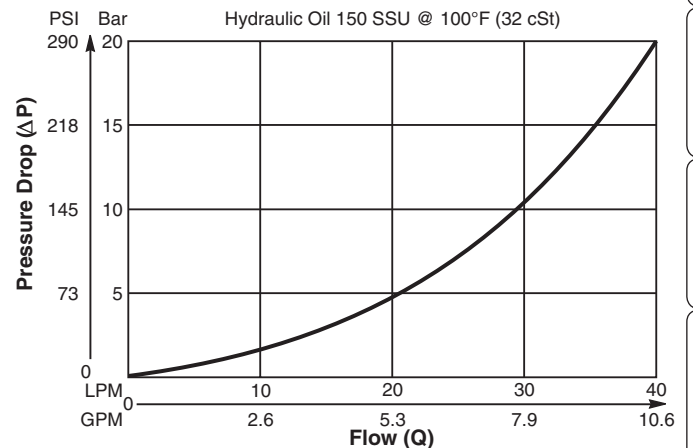

CV
Check Valves
SH
Shuttle Valves
LM
Load/Motor Controls
FC
Flow Controls
PC
Pressure Controls
LE
Logic Elements
DC
Directional Controls
SV
Solenoid Valves
PV
Proportional Valves
CE
Coils & Electronics
BC
Bodies & Cavities
TD
Technical Data

Dimensions Millimeters (Inches)

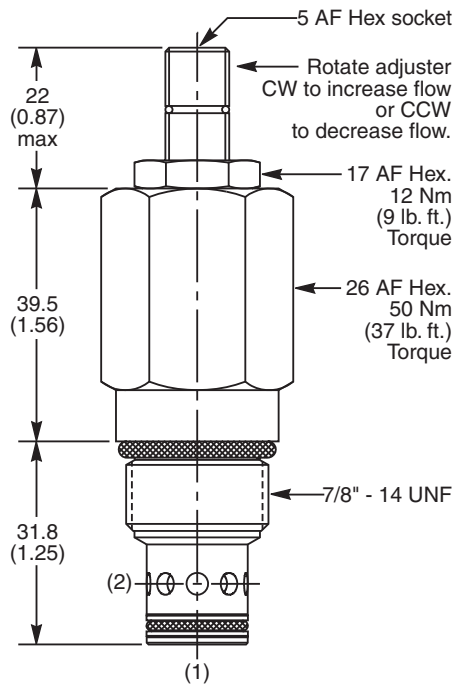

Ordering Information

J04E2	Z	N
10 Size Pressure Compensated Flow Control Valve	Adjustment Style	Seals

Highlighted represents preferred options that offer the shortest lead times. Other options may be available, but at extended lead times.

Code	Adjustment Style
Z	Screw Adjust

Code	Seals
N	Nitrile

Standard valve has a flow setting of 20 LPM.

*Order Bodies Separately
 See section BC*

B10	—	2	—	8T
10 size		2-Way Cavity		Port Size

Code	Porting / Body Material
8T	SAE-8 / Steel (5000 PSI)

Kit	Part Number
Knob	ASV014975
Tamper Resistant Cap	TC1130
Nitrile Seal	SK30503N-1
Fluorocarbon Seal	SK30503V-1

CV
Check Valves
SH
Shuttle Valves
LM
Load/Motor Controls
FC
Flow Controls
PC
Pressure Controls
LE
Logic Elements
DC
Directional Controls
SV
Solenoid Valves
PV
Proportional Valves
CE
Coils & Electronics
BC
Bodies & Cavities
TD
Technical Data

General Description

Fully Adjustable, Pressure Compensated Flow Control Valve. For additional information see Technical Tips on pages FC2-FC5.

Features

- Fully adjustable from 0.75 LPM (0.2 GPM) to 20.6 LPM (5.5 GPM)
- Hardened, precision ground parts for durability
- All external parts are zinc plated
- Compact size for reduced space requirements

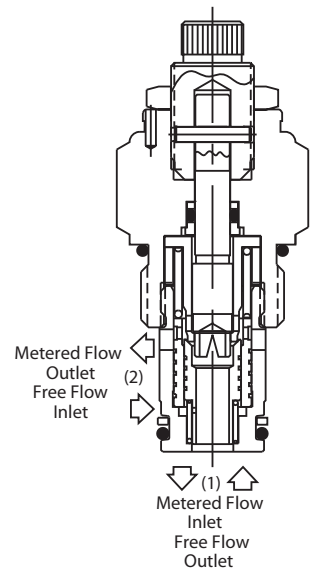
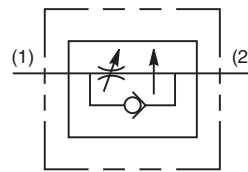

Specifications

Rated Flow	20.6 LPM (5.5 GPM)
Maximum Inlet Pressure	210 Bar (3000 PSI)
Cartridge Material	All parts steel. All operating parts hardened steel.
Operating Temp. Range/Seals	-34°C to +121°C (Nitrile) (-30°F to +250°F) -26°C to +204°C (Fluorocarbon) (-15°F to +400°F)
Fluid Compatibility/Viscosity	Mineral-based or synthetic with lubricating properties at viscosities of 45 to 2000 SSU (6 to 420 cSt)
Filtration	ISO-4406 18/16/13, SAE Class 4
Approx. Weight	0.23 kg (0.50 lbs.)
Cavity	C10-2 (See BC Section for more details)

Performance Curves

Regulated Flow vs. Pressure Drop
 (Through cartridge only)

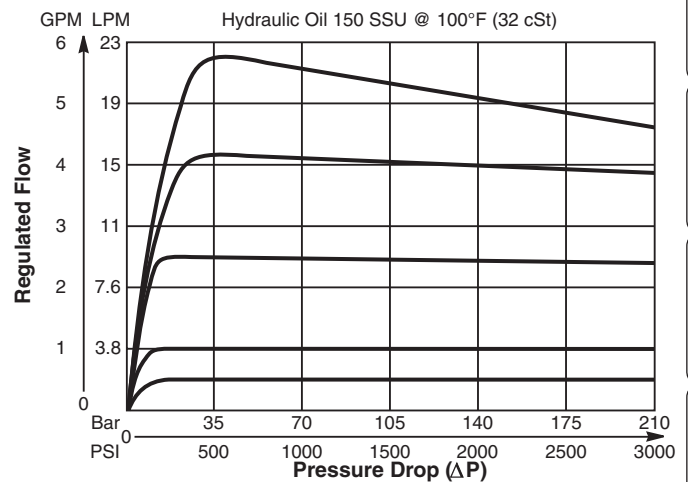

- CV
- Check Valves
- SH
- Shuttle Valves
- LM
- Load/Motor Controls
- FC
- Flow Controls
- PC
- Pressure Controls
- LE
- Logic Elements
- DC
- Directional Controls
- SV
- Solenoid Valves
- PV
- Proportional Valves
- CE
- Coils & Electronics
- BC
- Bodies & Cavities
- TD
- Technical Data

Dimensions Millimeters (Inches)

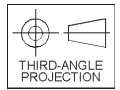
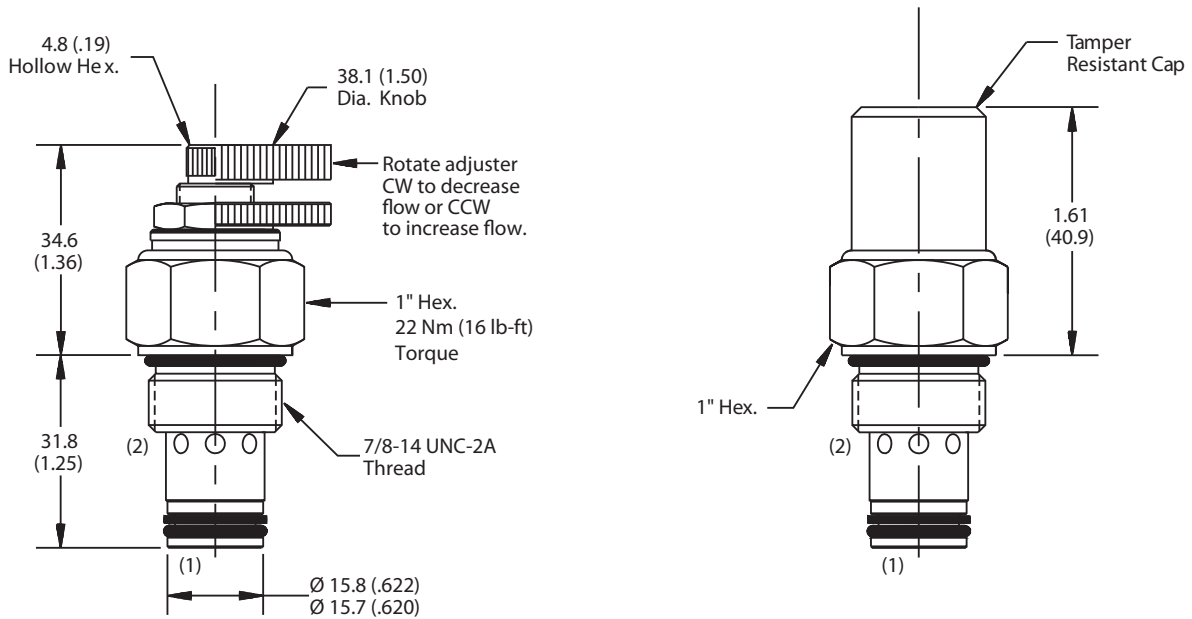

Ordering Information

FA101	S
10 Size Pressure Compensated Flow Control Valve	Adjustment Style

Highlighted represents preferred options that offer the shortest lead times. Other options may be available, but at extended lead times.

Code	Adjustment Style
S	Screw Adjust

Code	Seals
Omit	Nitrile

*Order Bodies Separately
 See section BC*

B10	—	2	—	8T
10 size		2-Way Cavity		Port Size

Code	Porting / Body Material
8T	SAE-8 / Steel (5000 PSI)

Kit	Part Number
Knob	717784-10
Tamper Resistant Cap	717785
Nitrile Seal	SK10-2
Fluorocarbon Seal	SK10-2V



CV
Check Valves
SH
Shuttle Valves
LM
Load/Motor Controls
FC
Flow Controls
PC
Pressure Controls
LE
Logic Elements
DC
Directional Controls
SV
Solenoid Valves
PV
Proportional Valves
CE
Coils & Electronics
BC
Bodies & Cavities
TD
Technical Data

General Description

Pressure Compensated Flow Control.
 For additional information see Technical Tips on pages FC2-FC5.

Features

- Hardened, precision ground parts for durability
- Compact size for reduced space requirements
- Free flow in reverse condition
- All external parts zinc plated

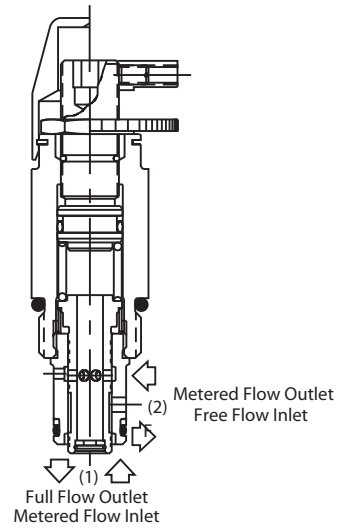
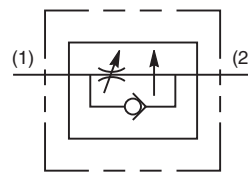

Specifications

Rated Flow	56 LPM (15 GPM)
Maximum Inlet Pressure	210 Bar (3000 PSI)
Cartridge Material	All parts steel. All operating parts hardened steel.
Operating Temp. Range/Seals	-34°C to +121°C (Nitrile) (-30°F to +250°F) -26°C to +204°C (Fluorocarbon) (-15°F to +400°F)
Fluid Compatibility/Viscosity	Mineral-based or synthetic with lubricating properties at viscosities of 45 to 2000 SSU (6 to 420 cSt)
Filtration	ISO-4406 18/16/13, SAE Class 4
Approx. Weight	0.23 kg (0.50 lbs.)
Cavity	C10-2 (See BC Section for more details)

Performance Curves

Regulated Flow vs. Pressure Drop
 (Through cartridge only)

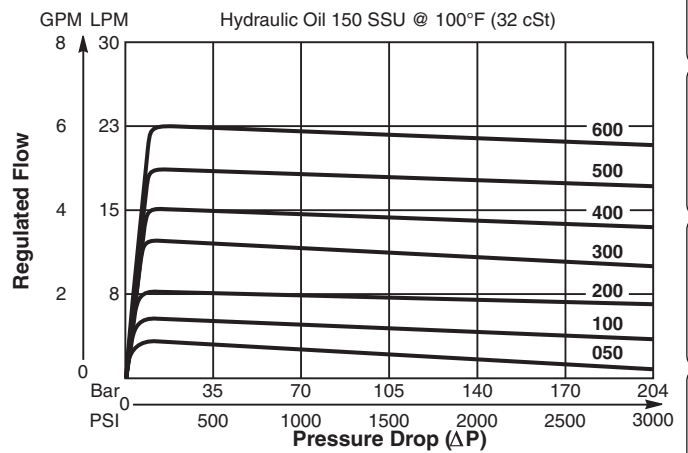

Pressure Drop vs. Flow (Through cartridge only)

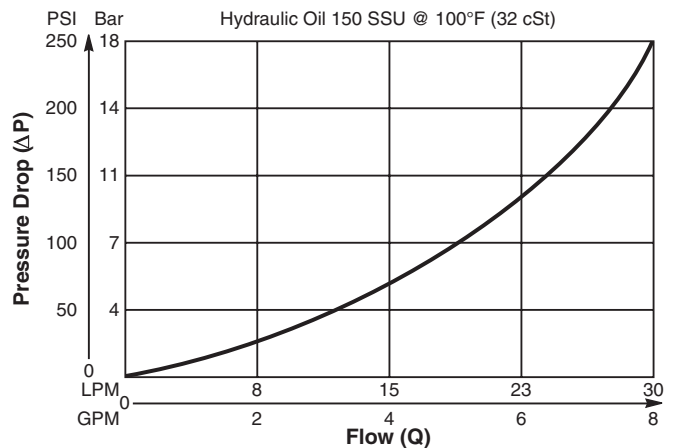

- CV Check Valves
- SH Shuttle Valves
- LM Load/Motor Controls
- FC Flow Controls**
- PC Pressure Controls
- LE Logic Elements
- DC Directional Controls
- SV Solenoid Valves
- PV Proportional Valves
- CE Coils & Electronics
- BC Bodies & Cavities
- TD Technical Data

Dimensions Millimeters (Inches)

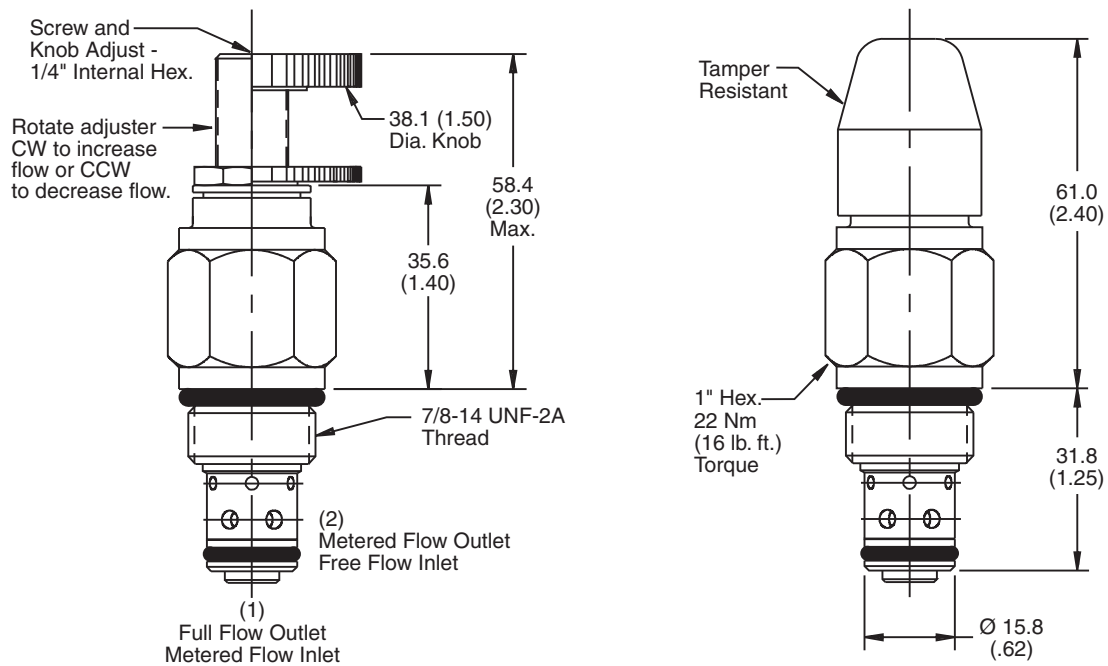

Ordering Information

FC101	S	
10 Size Pressure Compensated Flow Control	Adjustment Style	Flow Range

Highlighted represents preferred options that offer the shortest lead times. Other options may be available, but at extended lead times.

Code	Adjustment Style
S	Screw Adjust

Code	Flow Range and Standard Setting
300	7.5-16.9 LPM (2.0-4.5 GPM) (11.3 LPM (3 GPM) @ 69 Bar (1000 PSI) ΔP)
600	15-30 LPM (4.0-8.0 GPM) (22.5 LPM (6 GPM) @ 69 Bar (1000 PSI) ΔP)

Code	Seals
Omit	Nitrile

*Order Bodies Separately
 See section BC*

B10	—	2	—	8T
10 size		2-Way Cavity		Port Size

Code	Porting / Body Material
8T	SAE-8 / Steel (5000 PSI)

Kit	Part Number
Knob	840208K
Tamper Resistant Cap	717783
Nitrile Seal	SK10-2
Fluorocarbon Seal	SK10-2V

General Description

Priority Type, Pressure Compensated Flow Regulator Valve.

For additional information see Technical Tips on pages FC2-FC5.

Features

- Good adjustment from 1-15 LPM (0.3-4 GPM)
- Used for systems requiring priority flow such as steering systems
- Reverse flow function 3 to 1
- Hardened working parts for maximum durability
- All external parts zinc plated

Specifications

Rated Flow	15 LPM (4 GPM)
Maximum Inlet Pressure	420 Bar (6000 PSI)
Cartridge Material	All parts steel. All operating parts hardened steel.
Operating Temp. Range/Seals	-34°C to +121°C (Nitrile) (-30°F to +250°F) -26°C to +204°C (Fluorocarbon) (-15°F to +400°F)
Fluid Compatibility/Viscosity	Mineral-based or synthetic with lubricating properties at viscosities of 45 to 2000 SSU (6 to 420 cSt)
Filtration	ISO-4406 18/16/13, SAE Class 4
Approx. Weight	0.08 kg (0.18 lbs.)
Cavity	C08-3 (See BC Section for more details)

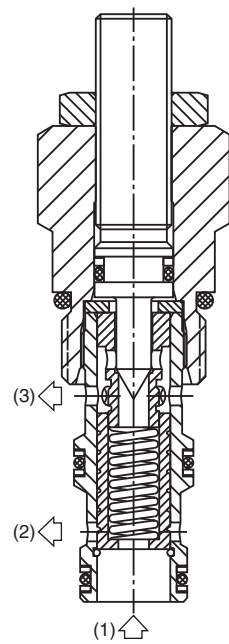
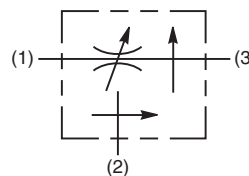
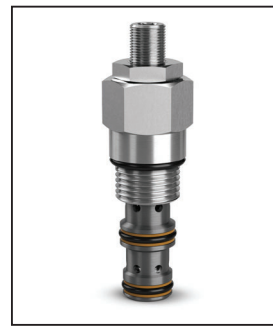

Performance Curves

Flow vs. Inlet Pressure (Through cartridge only)

Flow Regulating Performance

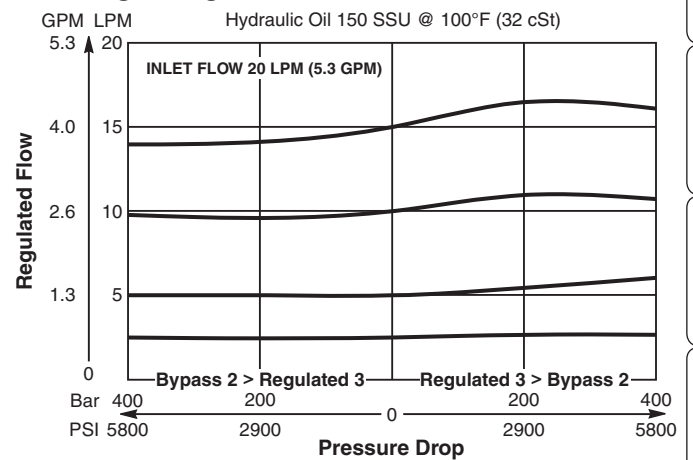

Application

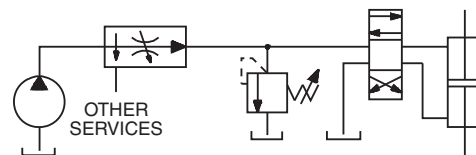

Priority flow on steering circuit

CV
Check Valves

SH
Shuttle Valves

LM
Load/Motor Controls

FC
Flow Controls

PC
Pressure Controls

LE
Logic Elements

DC
Directional Controls

SV
Solenoid Valves

PV
Proportional Valves

CE
Coils & Electronics

BC
Bodies & Cavities

TD
Technical Data

Dimensions Millimeters (Inches)

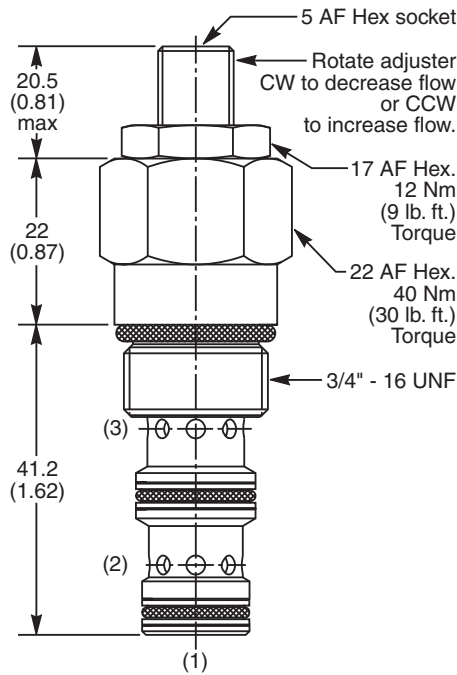

Ordering Information

J02D3	Z	N
Pressure Compensated Priority Flow Control Valve	Adjustment Style	Seals

Highlighted represents preferred options that offer the shortest lead times. Other options may be available, but at extended lead times.

Code	Adjustment Style
Z	Screw Adjust

Code	Seals
N	Nitrile

Standard valve has a flow setting of 7 LPM.

*Order Bodies Separately
 See section BC*

B08	—	3	—	6T
08 size		3-Way Cavity		Port Size

Code	Porting / Body Material
6T	SAE-6 / Steel (5000 PSI)

Kit	Part Number
Knob	ASV014975
Tamper Resistant Cap	TC1130
Nitrile Seal	SK30501N-1
Fluorocarbon Seal	SK30501V-1

CV	Check Valves
SH	Shuttle Valves
LM	Load/Motor Controls
FC	Flow Controls
PC	Pressure Controls
LE	Logic Elements
DC	Directional Controls
SV	Solenoid Valves
PV	Proportional Valves
CE	Coils & Electronics
BC	Bodies & Cavities
TD	Technical Data

General Description

Priority Type, Pressure Compensated Flow Regulator Valve.

For additional information see Technical Tips on pages FC2-FC5.

Features

- High flow capacity
- Good adjustment from 2-45 LPM (0.5-12 GPM)
- Used for systems requiring priority flow such as steering systems
- Reverse flow function 3 to 1
- Hardened working parts for maximum durability
- All external parts zinc plated

Specifications

Rated Flow	70 LPM (18 GPM)
Maximum Regulated Flow	45 LPM (12 GPM)
Maximum Inlet Pressure	420 Bar (6000 PSI)
Cartridge Material	All parts steel. All operating parts hardened steel.
Operating Temp. Range/Seals	-34°C to +121°C (Nitrile) (-30°F to +250°F) -26°C to +204°C (Fluorocarbon) (-15°F to +400°F)
Fluid Compatibility/Viscosity	Mineral-based or synthetic with lubricating properties at viscosities of 45 to 2000 SSU (6 to 420 cSt)
Filtration	ISO-4406 18/16/13, SAE Class 4
Approx. Weight	0.18 kg (0.40 lbs.)
Cavity	C10-3 (See BC Section for more details)

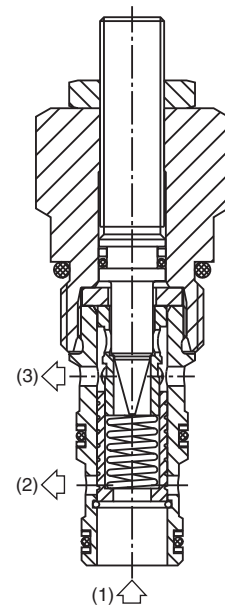
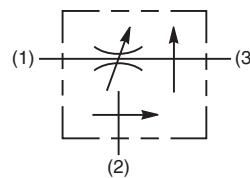

Performance Curves

Flow vs. Inlet Pressure (Through cartridge only)

Flow Regulating Performance

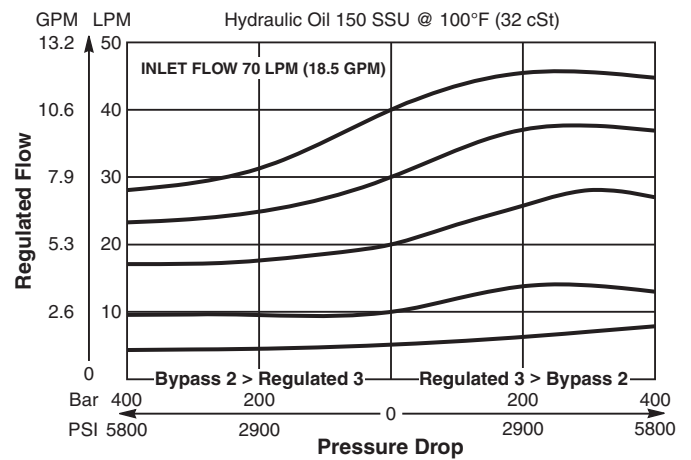

Application

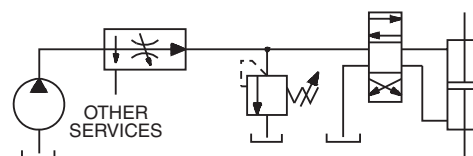

Priority flow on steering circuit

CV
Check Valves
SH
Shuttle Valves
LM
Load/Motor Controls
FC
Flow Controls
PC
Pressure Controls
LE
Logic Elements
DC
Directional Controls
SV
Solenoid Valves
PV
Proportional Valves
CE
Coils & Electronics
BC
Bodies & Cavities
TD
Technical Data

Dimensions Millimeters (Inches)

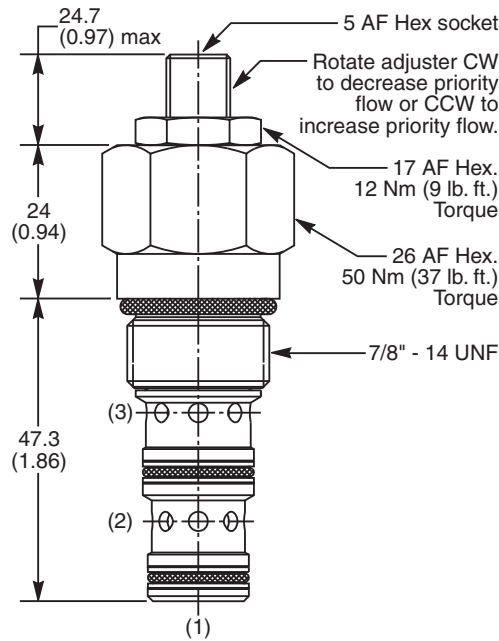

Ordering Information

J04D3	Z	N
Pressure Compensated Priority Flow Control Valve	Adjustment Style	Seals

Highlighted represents preferred options that offer the shortest lead times. Other options may be available, but at extended lead times.

Code	Adjustment Style
Z	Screw Adjust

Code	Seals
N	Nitrile

Standard valve has a flow setting of 20 LPM.

*Order Bodies Separately
 See section BC*

B10	—	3	—	8T
10 size		3-Way Cavity		Port Size

Code	Porting / Body Material
8T	SAE-8 / Steel (5000 PSI)

Kit	Part Number
Knob	ASV014975
Tamper Resistant Cap	TC1130
Nitrile Seal	SK30505N-1
Fluorocarbon Seal	SK30505V-1



CV	Check Valves
SH	Shuttle Valves
LM	Load/Motor Controls
FC	Flow Controls
PC	Pressure Controls
LE	Logic Elements
DC	Directional Controls
SV	Solenoid Valves
PV	Proportional Valves
CE	Coils & Electronics
BC	Bodies & Cavities
TD	Technical Data

General Description

Priority Style, Pressure Compensated Flow Regulator Valve With Bypass.
 For additional information see Technical Tips on pages FC2-FC5.

Features

- Free reverse flow function
- High flow capacity
- Used for systems requiring priority flow such as steering systems
- Hardened working parts for maximum durability
- All external parts zinc plated

Specifications

Rated Flow	150 LPM (40 GPM)
Maximum Regulated Flow	90 LPM (24 GPM)
Maximum Inlet Pressure	350 Bar (5000 PSI)
Cartridge Material	All parts steel. All operating parts hardened steel.
Operating Temp. Range/Seals	-34°C to +121°C (Nitrile) (-30°F to +250°F) -26°C to +204°C (Fluorocarbon) (-15°F to +400°F)
Fluid Compatibility/Viscosity	Mineral-based or synthetic with lubricating properties at viscosities of 45 to 2000 SSU (6 to 420 cSt)
Filtration	ISO-4406 18/16/13, SAE Class 4
Approx. Weight	0.45 kg (1.0 lbs.)
Cavity	3A (See BC Section for more details)

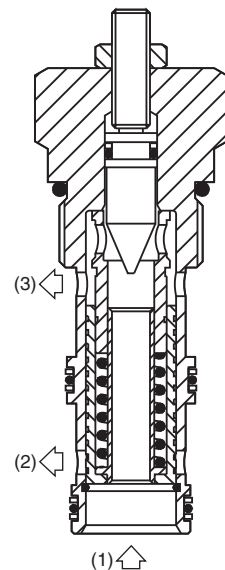
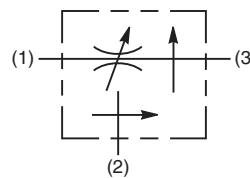
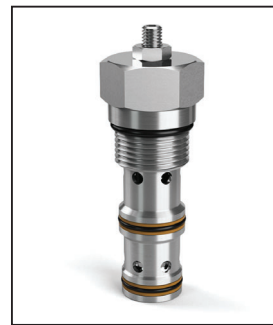

Performance Curves

Flow vs. Inlet Pressure (Through cartridge only)

Flow Regulating Performance

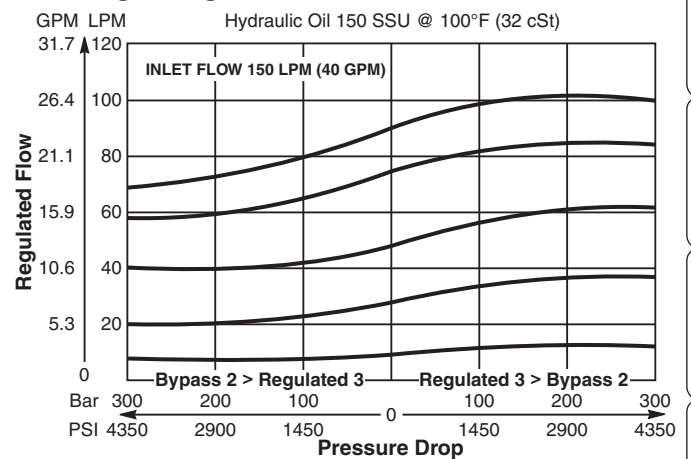

Application

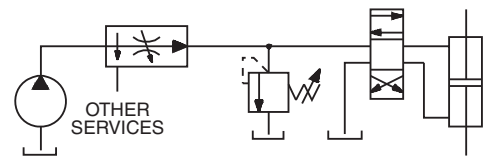

Priority flow on steering circuit

CV
Check Valves

SH
Shuttle Valves

LM
Load/Motor Controls

FC
Flow Controls

PC
Pressure Controls

LE
Logic Elements

DC
Directional Controls

SV
Solenoid Valves

PV
Proportional Valves

CE
Coils & Electronics

BC
Bodies & Cavities

TD
Technical Data

Dimensions Millimeters (Inches)

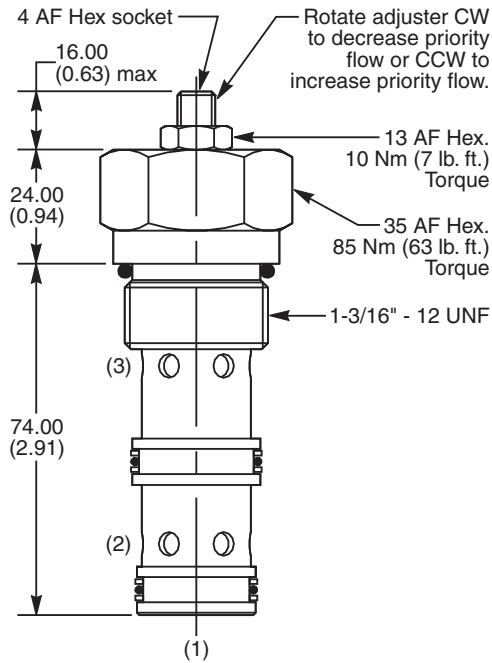

Ordering Information

J1A125	Z	N
Pressure Compensated Priority Flow Control Valve	Adjustment Style	Seals

Highlighted represents preferred options that offer the shortest lead times. Other options may be available, but at extended lead times.

Code	Adjustment Style
Z	Screw Adjust

Code	Seals
N	Nitrile

Standard valve has a flow setting of 25 LPM and an Inlet flow setting of 45 LPM.

*Order Bodies Separately
 See section BC*

LB10	066	S
Line Body	Porting	Body Material

Code	Porting
066	SAE16 /Steel (5000 PSI)

Kit	Part Number
Nitrile Seal	SK30011N-1
Fluorocarbon Seal	SK30011V-1



CV	Check Valves
SH	Shuttle Valves
LM	Load/Motor Controls
FC	Flow Controls
PC	Pressure Controls
LE	Logic Elements
DC	Directional Controls
SV	Solenoid Valves
PV	Proportional Valves
CE	Coils & Electronics
BC	Bodies & Cavities
TD	Technical Data

General Description

Spool Type, Flow Divider/Combiner Valve.
 For additional information see Technical Tips on pages FC2-FC5.

Features

- Interlocking spools for equal control dividing or combining
- Range of flow settings available for optimising control
- Pressure compensated control in both directions
- 50/50 ratio standard, other ratios available on request
- Commonly used for differential lock in transmission applications
- Hardened working parts for maximum durability
- All external parts zinc plated

Specifications

Rated Flow	60 LPM (16 GPM)
Maximum Inlet Pressure	420 LPM (6000 PSI)
Flow Rating and Ratio	See Ordering Information
Accuracy Per Leg	±10%
Cartridge Material	All parts steel. All operating parts hardened steel.
Operating Temp. Range/Seals	-34°C to +121°C (Nitrile) (-30°F to +250°F) -26°C to +204°C (Fluorocarbon) (-15°F to +400°F)
Fluid Compatibility/Viscosity	Mineral-based or synthetic with lubricating properties at viscosities of 45 to 2000 SSU (6 to 420 cSt)
Filtration	ISO-4406 18/16/13, SAE Class 4
Approx. Weight	0.12 kg (0.26 lbs.)
Cavity	C10-4 (See BC Section for more details)

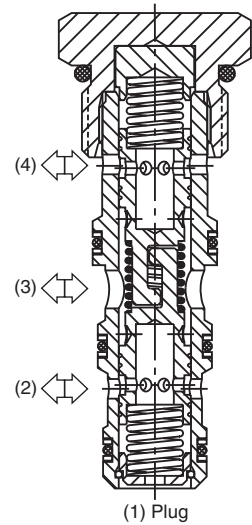
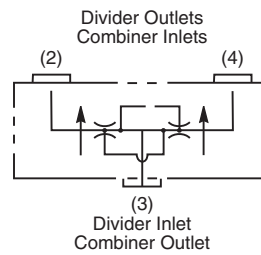

Performance Curves

Flow vs. Inlet Pressure (Through cartridge only)

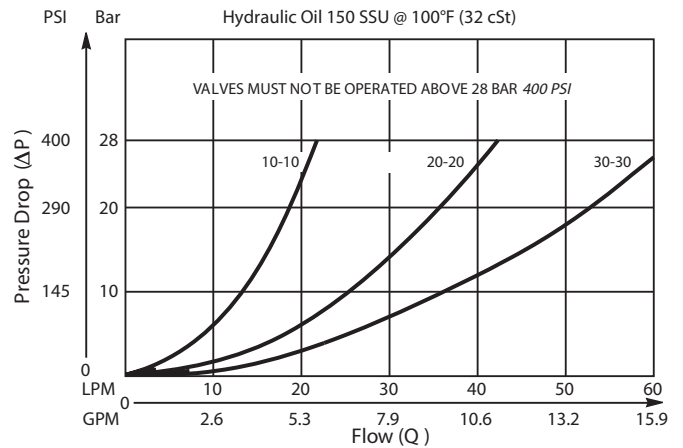

- CV
- Check Valves
- SH
- Shuttle Valves
- LM
- Load/Motor Controls
- FC
- Flow Controls
- PC
- Pressure Controls
- LE
- Logic Elements
- DC
- Directional Controls
- SV
- Solenoid Valves
- PV
- Proportional Valves
- CE
- Coils & Electronics
- BC
- Bodies & Cavities
- TD
- Technical Data

Dimensions Millimeters (Inches)

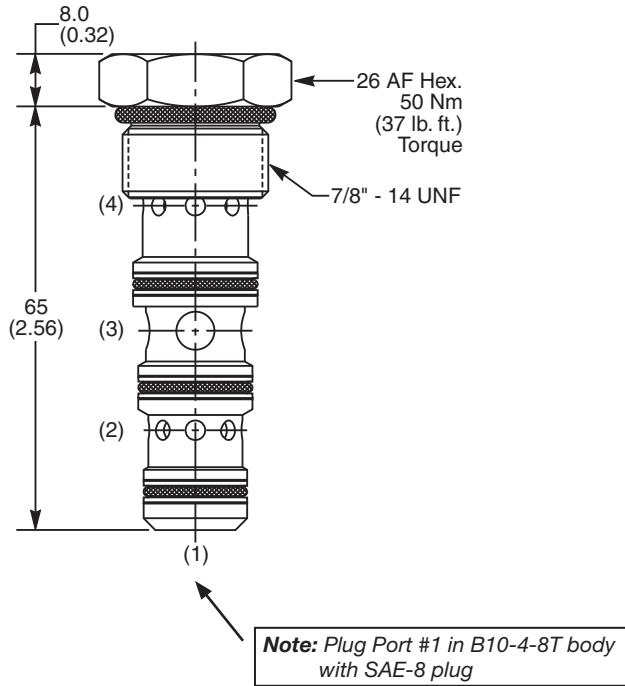

Note: Plug Port #1 in B10-4-8T body with SAE-8 plug

Ordering Information

L04A3 — **N**

Size 10 Flow Divider Combiner Valve Flow Rating and Ratio Seals

Highlighted represents preferred options that offer the shortest lead times. Other options may be available, but at extended lead times.

Code	Total Flow Rating - Port 3 (Flow Ratio)
10-10	8-20 LPM (2.1-5.3 GPM) (50/50 Ratio)
20-20	12-40 LPM (3.2-10.6 GPM) (50/50 Ratio)
30-30	14-60 LPM (3.7-15.9 GPM) (50/50 Ratio)

Code	Seals
N	Nitrile

Order Bodies Separately
 See section BC

B10 — **4** — **8T**

10 size 4-Way Cavity Port Size

Code	Porting / Body Material
8T	SAE-8 / Steel (5000 PSI)

Kit	Part Number
Nitrile Seal	SK30506N-1
Fluorocarbon Seal	SK30506V-1

CV
Check Valves

SH
Shuttle Valves

LM
Load/Motor Controls

FC
Flow Controls

PC
Pressure Controls

LE
Logic Elements

DC
Directional Controls

SV
Solenoid Valves

PV
Proportional Valves

CE
Coils & Electronics

BC
Bodies & Cavities

TD
Technical Data

General Description

Spool Type, Flow Divider/Combiner Valve.
 For additional information see Technical Tips on pages FC2-FC5.

Features

- Interlocking spools for equal control dividing or combining
- Range of flow settings available for optimising control
- Pressure compensated control in both directions
- 50/50 ratio standard, other ratios available on request
- Commonly used for differential lock in transmission applications
- Hardened working parts for maximum durability
- All external parts zinc plated

Specifications

Rated Flow	180 LPM (47 GPM)
Maximum Inlet Pressure	420 LPM (6000 PSI)
Flow Rating and Ratio	See Ordering Information
Accuracy Per Leg	±10%
Cartridge Material	All parts steel. All operating parts hardened steel.
Operating Temp. Range/Seals	-34°C to +121°C (Nitrile) (-30°F to +250°F) -26°C to +204°C (Fluorocarbon) (-15°F to +400°F)
Fluid Compatibility/Viscosity	Mineral-based or synthetic with lubricating properties at viscosities of 45 to 2000 SSU (6 to 420 cSt)
Filtration	ISO-4406 18/16/13, SAE Class 4
Approx. Weight	0.40 kg (0.86 lbs.)
Cavity	C16-4 (See BC Section for more details)

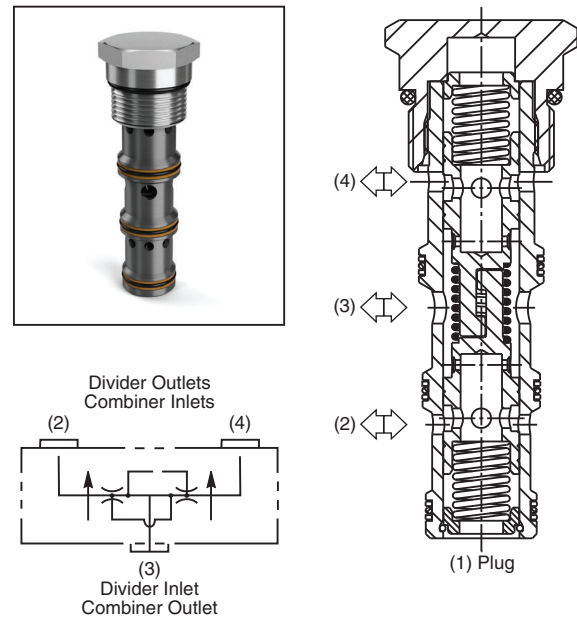

Performance Curve

Pressure Drop vs. Flow (Through cartridge only)

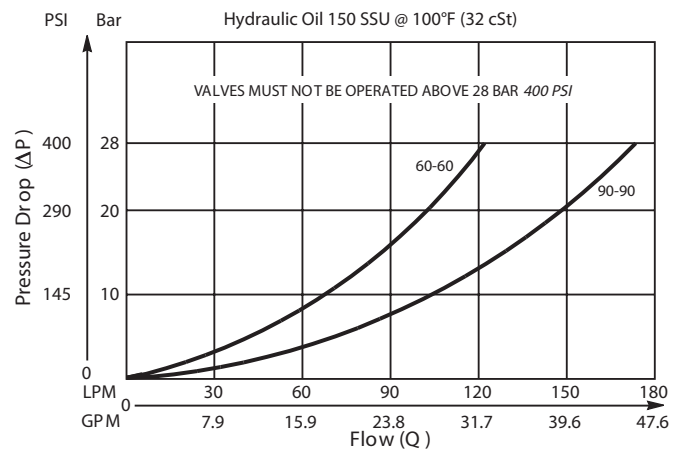

CV	Check Valves
SH	Shuttle Valves
LM	Load/Motor Controls
FC	Flow Controls
PC	Pressure Controls
LE	Logic Elements
DC	Directional Controls
SV	Solenoid Valves
PV	Proportional Valves
CE	Coils & Electronics
BC	Bodies & Cavities
TD	Technical Data

Dimensions Millimeters (Inches)

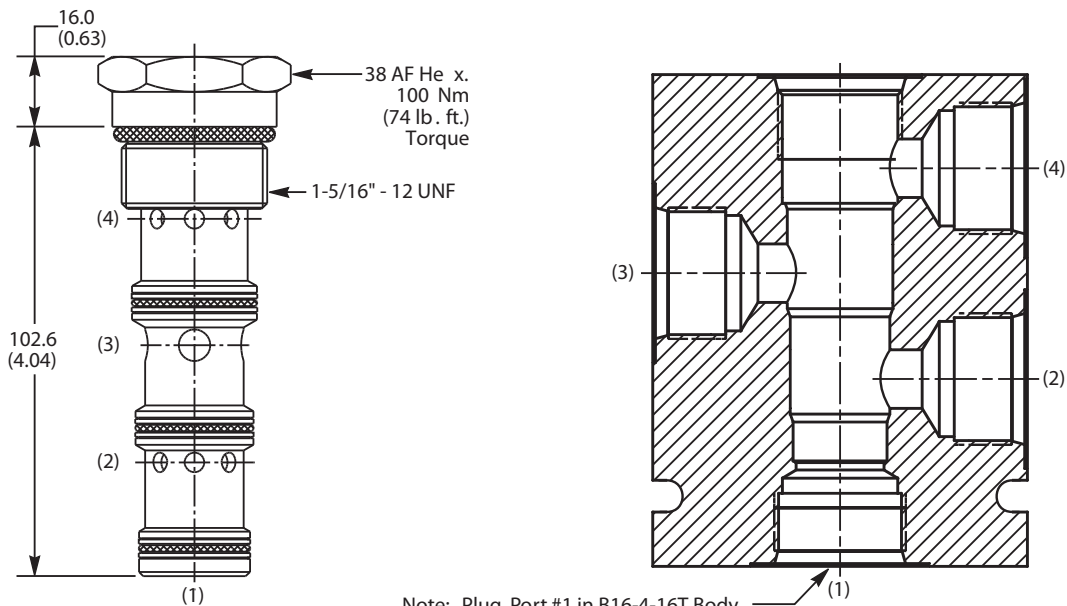

Note: Plug Port #1 in B16-4-16T Body with SAE-16 plug.

Ordering Information

L06A3 — — **N**

16 Size Flow Divider/Combiner Valve Flow Rating and Ratio Seals

Highlighted represents preferred options that offer the shortest lead times. Other options may be available, but at extended lead times.

Code	Total Flow Rating - Port 3 (Flow Ratio)
60-60	35-120 LPM (9.2-31.7 GPM) (50/50 Ratio)
90-90	65-180 LPM (17.2-47.8 GPM) (50/50 Ratio)

Code	Seals
N	Nitrile

Order Bodies Separately
 See section BC

B16 — **4** — **16T**

16 size 4-Way Cavity Port Size

Code	Porting / Body Material
16T	SAE-16 / Steel (5000 PSI)

Kit	Part Number
Nitrile Seal	SK30510N-1
Fluorocarbon Seal	SK30510V-1

- CV Check Valves
- SH Shuttle Valves
- LM Load/Motor Controls
- FC Flow Controls**
- PC Pressure Controls
- LE Logic Elements
- DC Directional Controls
- SV Solenoid Valves
- PV Proportional Valves
- CE Coils & Electronics
- BC Bodies & Cavities
- TD Technical Data

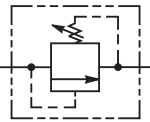
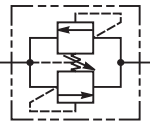
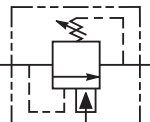
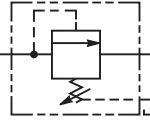
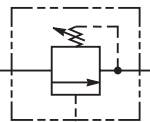
	SERIES	CAVITY	DESCRIPTION	FLOW LPM/GPM	PRESSURE BAR/PSI	PAGE NO.
	Technical Tips					PC3-PC7
RELIEF VALVES	DIRECT ACTING					
	RDH081	C08-2	Direct Acting Relief, Ball Type	1.9/5	380/5500	PC8-PC9
	RDH082	C08-2	Direct Acting Relief, Poppet Type	.30/8	380/5500	PC10-PC11
	RDH101	C10-2	Direct Acting Relief, Ball Type	1.9/5	380/5500	PC12-PC13
	RD102	C10-2	Direct Acting Relief, Poppet Type	.38/10	250/3600	PC14-PC15
	A04B2	C10-2	Direct Acting Relief, Poppet Type	100/26	420/6000	PC16-PC17
	DIFFERENTIAL AREA					
	RDH083	C08-2	Direct Acting Differential Area Relief	.45/12	350/5000	PC18-PC19
	RDH103	C10-2	Direct Acting Differential Area Relief	.75/20	350/5000	PC20-PC21
	RD163	C16-2	Direct Acting Differential Area Relief	151/40	210/3000	PC22-PC23
	PILOT OPERATED					
	RAH081	C08-2	Pilot Operated Spool Type	.75.8/20	350/5000	PC24-PC25
	RAH101	C10-2	Pilot Operated Spool Type	113/30	350/5000	PC26-PC27
	RAH121	C12-2	Pilot Operated Spool Type	190/50	350/5000	PC28-PC29
	RAH161	C16-2	Pilot Operated Spool Type	303/80	380/5500	PC30-PC31
	RAH201	C20-2	Pilot Operated Spool Type	379/100	350/5000	PC32-PC33
	CROSS-OVER					
	A04J2	C10-2	Direct Acting Cross-over Relief	120/32	350/5000	PC34-PC35
	UNLOADING					
	RU104	C10-4	Direct Acting Unloading	1/0.25	250/3600	PC36-PC37
SEQUENCE VALVES	PILOT OPERATED					
	SVH081	C08-3	Pilot Operated, Int. Pilot, Ext. Drain	.45/12	350/5000	PC38-PC39
	SVH101	C10-3	Pilot Operated, Int. Pilot, Ext. Drain	.56.3/15	350/5000	PC40-PC41
	SVH161	C16-3	Pilot Operated, Int. Pilot, Ext. Drain	151.6/40	350/5000	PC42-PC43
	SVH102	C10-3	Pilot Operated, Ext. Pilot, Int. Drain	.56.3/15	350/5000	PC44-PC45
	SVH162	C16-3	Pilot Operated, Ext. Pilot, Int. Drain	151.6/40	350/5000	PC46-PC47

CV
Check Valves

SH
Shuttle Valves

LM
Load/Motor Controls

FC
Flow Controls

PC
Pressure Controls

LE
Logic Elements

DC
Directional Controls

SV
Solenoid Valves

PV
Proportional Valves

CE
Coils & Electronics

BC
Bodies & Cavities

TD
Technical Data

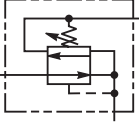
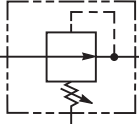
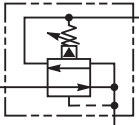
	SERIES	CAVITY	DESCRIPTION	FLOW LPM/GPM	PRESSURE BAR/PSI	PAGE NO.
REDUCING VALVES	DIRECT ACTING					
	PR103	C10-3	Direct Acting Reducing/Relieving	56/15	210/3000	PC48-PC49
	PILOT OPERATED					
	PRH082	C08-3	Pilot Operated Reducing	30/8	350/5000	PC50-PC51
	PRH102	C10-3	Pilot Operated Reducing	56.3/15	350/5000	PC52-PC53
	PRH081	C08-3	Pilot Operated Reducing/Relieving	30/8	350/5000	PC54-PC55
	PRH101	C10-3	Pilot Operated Reducing/Relieving	56.3/15	350/5000	PC56-PC57
	PRH161	C16-3	Pilot Operated Reducing/Relieving	150/40	350/5000	PC58-PC59

CV
Check Valves

SH
Shuttle Valves

LM
Load/Motor Controls

FC
Flow Controls

PC
Pressure Controls

LE
Logic Elements

DC
Directional Controls

SV
Solenoid Valves

PV
Proportional Valves

CE
Coils & Electronics

BC
Bodies & Cavities

TD
Technical Data

INTRODUCTION

This technical tips section is designed to help familiarize you with the Parker line of Pressure Controls. In this section we highlight new products to this catalog as well as some design features of our pressure control line. In addition we present common options available to help you in selecting products for your application. Finally we give a brief synopsis of the operation and applications of the various product offered in this section.

NEW PRODUCTS

There are several new additions and product improvements to our Pressure Controls product line.

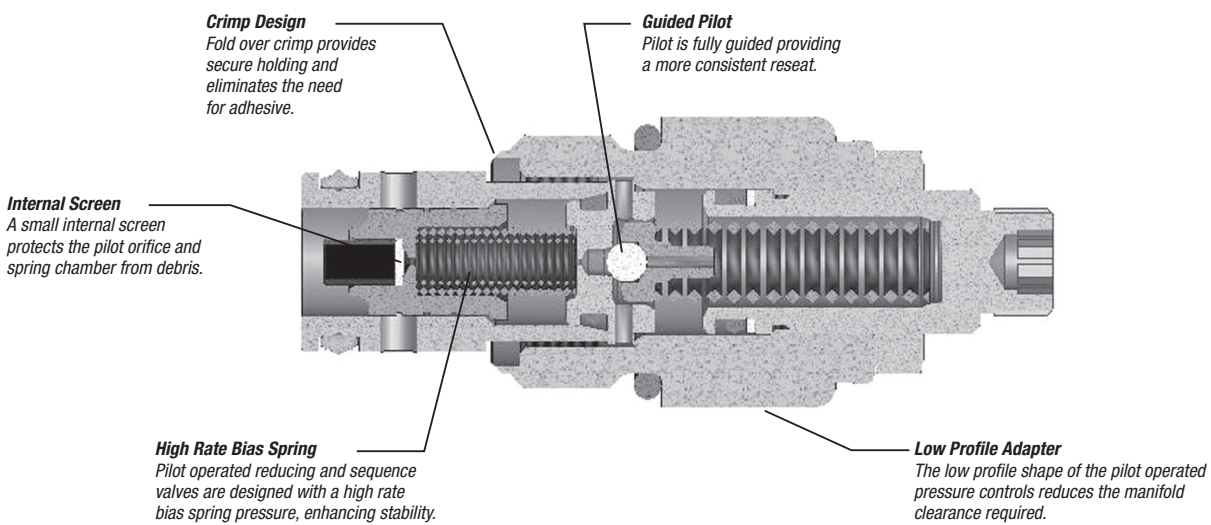
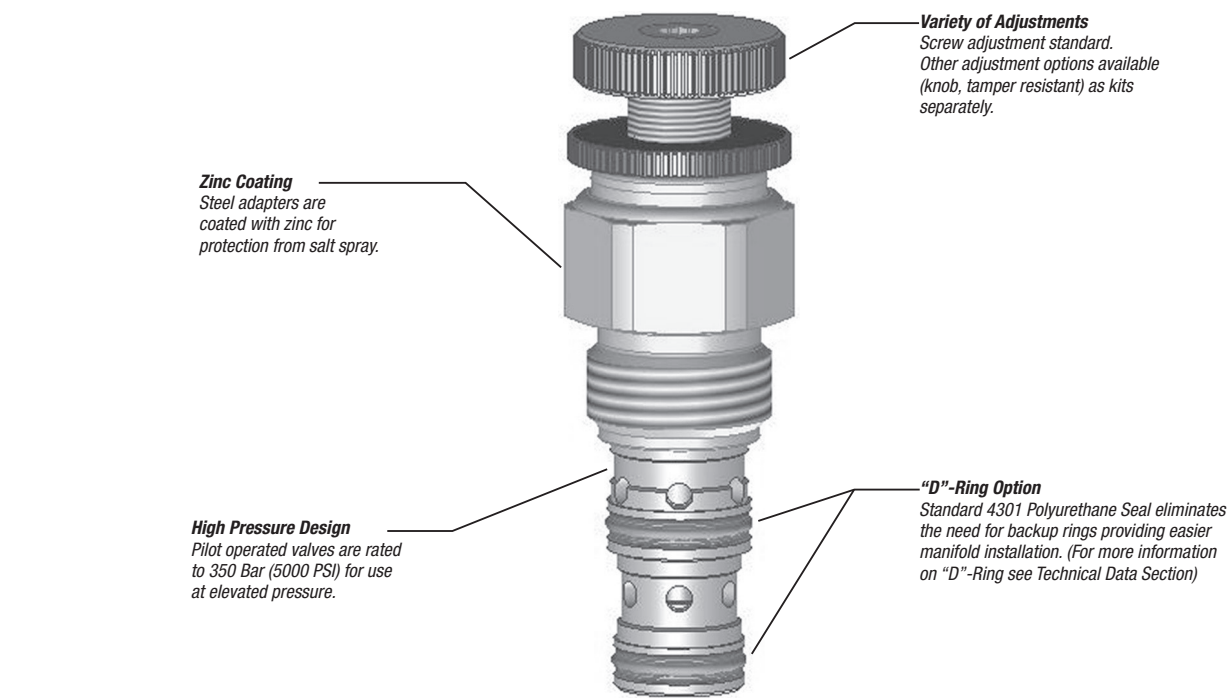

CV
Check Valves

SH
Shuttle Valves

LM
Load/Motor Controls

FC
Flow Controls

PC
Pressure Controls

LE
Logic Elements

DC
Directional Controls

SV
Solenoid Valves

PV
Proportional Valves

CE
Coils & Electronics

BC
Bodies & Cavities

TD
Technical Data

COMMON OPTIONS

As you will see, Parker offers a variety of Pressure Control products. As such, some of the options mentioned below may not be available on all valves. Consult the model coding and dimensions for each valve for specifics. Here are some of the common options available.

Adjustment Types: Parker offers three primary types of adjustments for most of the pressure control products. Samples of these types are shown below. Please note all options may not be available for all valves. Consult the individual catalog pages for more details.

Screw Adjustment - Valve can be adjusted with an allen wrench. Lock nut included to maintain desired setting after adjustment. This is the most common adjustment option available on most Parker products.

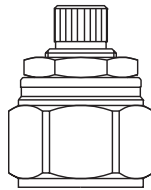

Knob Adjustment - An aluminum knob is added to the standard screw adjustment. A lock knob is provided to help maintain the desired setting after adjustment. Parker offers knob conversion kits for most pressure control valves. For kit numbers consult individual valve pages.

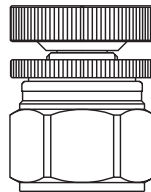

Tamper Resistant - The tamper resistant option is a screw adjustable valve with a steel cap installed to conceal the adjustment. The cap is designed so that the internal edges clamp into the groove of the valve adapter. Once the cap is installed, it cannot be removed without damaging the cap and the valve. When a valve is ordered with the tamper resistant option, it will be preset at the factory, and the cap will be included in a separate plastic bag to allow for fine tuning at the customer site. Parker offers tamper resistant cap conversion kits for most pressure control valves. For kit numbers consult individual valve pages.

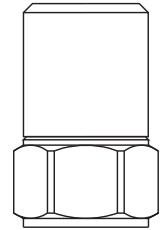

Seals: Valves feature either a 4301 Polyurethane “D”-Ring. The “D”-Ring eliminates the need for backup rings. The majority of the products are also available in Nitrile or Fluorocarbon seals. Contact factory for availability. You should match the seal compatibility to the temperature and fluid being used in your application.

Pressure Range: Parker offers a range of spring settings for the Pressure Control product line. You want to choose the setting that best meets the operating range. The model callout is equivalent to the maximum setting (in psi) of the spring divided by 100 (i.e. 50 = 5000 psi).

CV
Check Valves

SH
Shuttle Valves

LM
Load/Motor Controls

FC
Flow Controls

PC
Pressure Controls

LE
Logic Elements

DC
Directional Controls

SV
Solenoid Valves

PV
Proportional Valves

CE
Coils & Electronics

BC
Bodies & Cavities

TD
Technical Data

PRODUCT TYPES / APPLICATIONS

Direct Acting Relief Valves

Direct acting relief valves are designed for fast response in intermittent duty applications. They are often used as an economical solution to clip pressure spikes. The poppet design allows for low leakage.

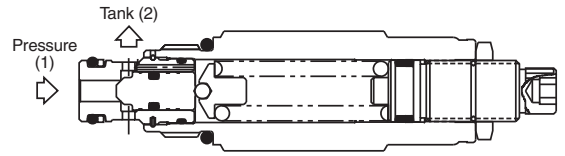
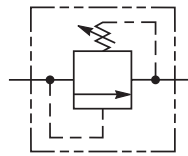

OPERATION - The valve poppet is held against the seat by the spring force. Inlet pressure on the nose (port 1) of the poppet acts against the spring force to unseat the poppet at the valve setting and allow flow to pass to tank. Since the pressure is working directly on the spring, this valve is very fast responding. It is not the best choice for system pressure regulation as it is slightly noisier than pilot operated relief valves and has higher pressure rise.
Note: Any backpressure on port 2 would be additive to the spring setting.

Differential Area Relief Valves

Differential area relief valves also are also best suited for intermittent applications where fast response is critical. These valves are often used as cross-over relief valves to chop pressure spikes. Due to their design, they generally can handle a larger flow rate and have a lower pressure rise than the standard directing acting relief. The poppet design allows for low leakage.

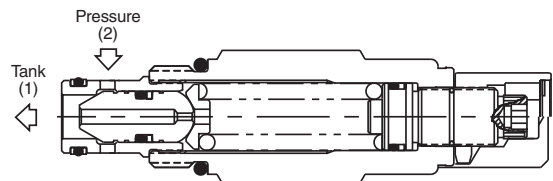
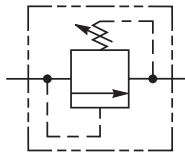

OPERATION - Pressure on the inlet (port 2) of the valve acts on the differential area of the poppet (difference between the O.D. of the poppet and the seat diameter) to produce a force which is opposed by the spring force. When pressure reaches the valve setting, the poppet is pushed off its seat, permitting flow to tank.
Note: Any backpressure on port 1 would be additive to the spring setting.

Pilot Operated Relief

Pilot operated relief valves are designed for continuous duty applications. Due to their stability and low pressure rise, the pilot operated relief is the best option for setting the pressure of a hydraulic system.

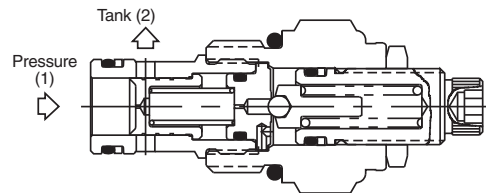
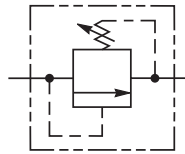

OPERATION - When inlet pressure at the nose (port 1) exceeds the valve setting, the pilot ball unseats. The pilot flow creates a pressure imbalance across the main spool causing the spool to move and allowing flow from inlet (port 1) to tank (port 2.) *Note:* Any backpressure on port 2 would be additive to the spring setting.

CV

Check Valves

SH

Shuttle Valves

LM

Load/Motor Controls

FC

Flow Controls

PC

Pressure Controls

LE

Logic Elements

DC

Directional Controls

SV

Solenoid Valves

PV

Proportional Valves

CE

Coils & Electronics

BC

Bodies & Cavities

TD

Technical Data

Dual Crossover Relief Valves

Dual crossover relief valves provide pressure surge protection for double acting hydraulic actuators. For best results, you always want to install the valve as close to the actuator as possible. The dual crossover feature can be achieved in two different methods. One way is to manifold two Differential Area Relief Valves into a single body.

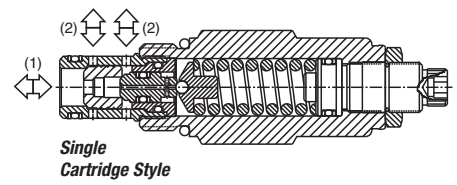
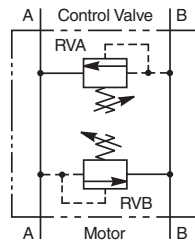

The advantage gained is higher flows can be pushed through this arrangement. The second method is to combine this dual function into a single cartridge. The single cartridge arrangement reduces cost considerably of the total package. In addition, a standard common cavity line body can be used instead of a special two body arrangement. The operation for the single cartridge style is shown below.

OPERATION - Pressure at port 1 acts on the spool to produce a force which is opposed by the spring setting. When pressure reaches the valve setting, the spool and poppet move relieving flow from port 1 to port 2. When port 2 is pressurized, the pressure acts on the differential area poppet to produce a force which is opposed by the spring force. When the pressure reaches the valve setting, the poppet is pushed off of its seat, relieving flow from port 2 to port 1. *Note:* Due to the construction and flow paths through the valve, the relief pressure settings may vary by approximately 300 psi from one direction to the other.

Differential Area Unloading Relief Valve

Unloading valves are differential area relief valves that can also be fully dumped or unloaded via a remote signal. They are best suited for low flow accumulator unloading circuits. They provide a fixed percentage between load and unload pressures. This pilot valve would generally be used in conjunction with a logic element.

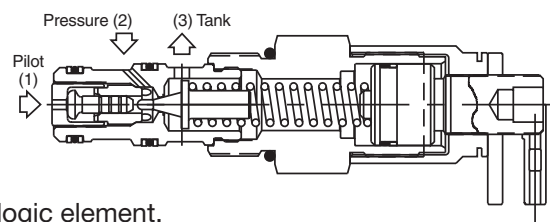
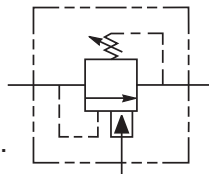

OPERATION - The fixed differential is provided by the pilot piston which has greater area than the dart seat. With its greater area, the piston is able to hold the dart off its seat, permitting flow from pressure to tank, until pressure on the pilot piston falls below the fixed percentage of the valve settings.

Pilot Operated Reducing Valve

Pilot operated pressure reducing valves can be used to reduce the pressure in a leg of the circuit lower than system pressure. Thus, they can be used to provide protection to downstream components from higher pressures.

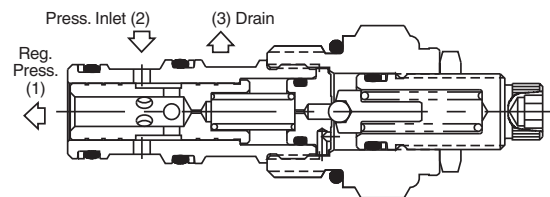
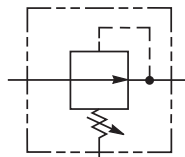

OPERATION - The pilot section controls the valve setting when reducing. As pressure at the regulated port exceeds the valve setting, the pilot ball is unseated. The pilot flow creates a pressure imbalance across the main spool causing the spool to throttle in order to maintain constant downstream pressure. The normally open design will allow flow to pass from inlet to reduced port with the only restriction being the pressure drop.

CV
Check Valves

SH
Shuttle Valves

LM
Load/Motor Controls

FC
Flow Controls

PC
Pressure Controls

LE
Logic Elements

DC
Directional Controls

SV
Solenoid Valves

PV
Proportional Valves

CE
Coils & Electronics

BC
Bodies & Cavities

TD
Technical Data

Pressure Reducing / Relieving Valves

Pressure reducing / relieving valves can be used to reduce the pressure in a leg of the circuit lower than system pressure. The valve also acts as a relief valve, relieving any shocks or surges that occur between the regulated port and the actuator. When the valve is in the relieving mode, the inlet port is blocked. Parker offers pressure reducing/relieving valves in both pilot operated and directing acting styles. The direct acting version is generally used in static applications where response is critical, or leakage is a concern.

Pilot Operated

OPERATION - The pilot section controls the valve setting when reducing. As pressure at the regulated port exceeds the valve setting, the pilot ball is un-seated. The pilot flow creates a pressure imbalance across the main spool causing the spool to throttle in order to maintain constant downstream pressure. A shock or surge at the regulated port shifts the spool, relieving flow to tank.

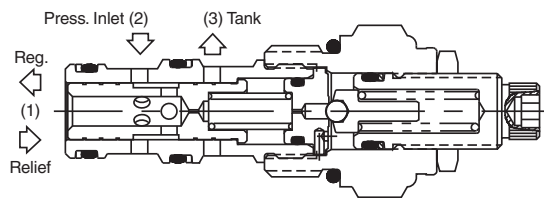
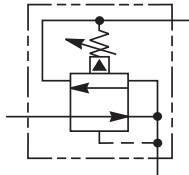

Direct Acting

OPERATION - As pressure at the regulated port exceeds the valve setting, the valve throttles or closes in order to maintain constant downstream pressure. A shock or surge at the regulated port further shifts the spool, relieving flow to tank. This valve is not intended for rapidly changing flows which could lead to instability.

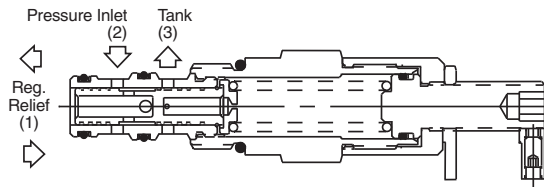

Pilot Operated Sequence Valves

Sequence valves are used to control the sequence of operation of two or more hydraulic actuators. The sequence valve pressure is set higher than the first actuator operation pressure. Once the first actuator has completed its cycle, the sequence valve opens allowing the second actuator to move. Parker's line of pilot operated sequence valves include a series of internally piloted, externally drained valves and a series of externally piloted, internally vented valves. Parker also offers a line of direct acting sequence valves which are ideal for piloting logic elements in steady state applications.

P.O. Sequence (Internally Piloted, Externally Drained)

OPERATION - For this valve, the pilot pressure is sensed from the inlet of the valve (port 1). When the pilot pressure exceeds the valve setting, the pilot section opens creating a pressure imbalance across the main spool. This causes the spool to move allowing the flow to pass from the nose of the cartridge (port 1) to the actuator port (port 2). By externally draining the pilot flow directly to tank (port 3), the valve is insensitive to back pressure at the sequence port.

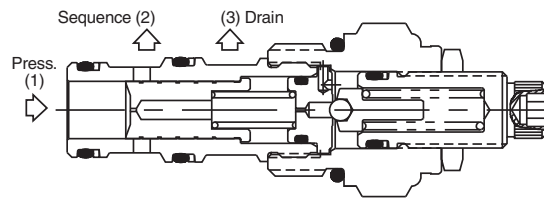

P.O. Sequence (Externally Piloted, Internally Vented)

OPERATION - For this valve, the pilot pressure is obtained from an external source and not from the pressure port. When the external pilot pressure (port 1) exceeds the valve setting, the pilot section opens creating a pressure imbalance across the main spool. This causes the spool to move allowing the flow to pass from the side of the cartridge (port 2) to the actuator port (port 3). Any pressure at port 3 is additive to the pressure setting. It is most common for port 3 to be connected to tank.

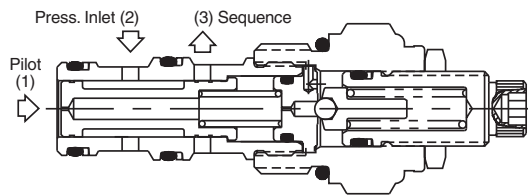

CV	Check Valves
SH	Shuttle Valves
LM	Load/Motor Controls
FC	Flow Controls
PC	Pressure Controls
LE	Logic Elements
DC	Directional Controls
SV	Solenoid Valves
PV	Proportional Valves
CE	Coils & Electronics
BC	Bodies & Cavities
TD	Technical Data

General Description

Direct Acting Relief Valve. This valve is designed for pilot flow circuits. For additional information see Technical Tips on pages PC3-PC7.

Features

- Hardened, precision ground parts for durability
- Low profile adapter for minimal space requirements
- Fully guided pilot for more consistent reseal
- Steel adapters are zinc plated
- Polyurethane “D”-Ring eliminates backup rings and prevents hydrolysis

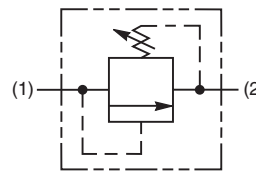
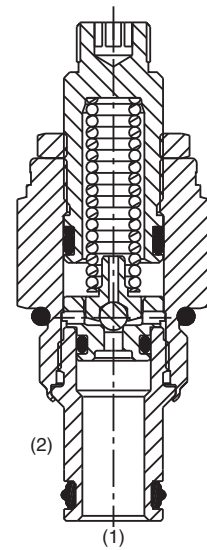

Specifications

Rated Flow	1.9 LPM (0.5 GPM)
Maximum Inlet Pressure	380 Bar (5500 PSI)
Maximum Pressure Setting	350 Bar (5000 PSI)
Sensitivity: Pressure/Turn	10 19.6 Bar (285 PSI) 30 58.9 Bar (859 PSI) 50 131.7 Bar (1910 PSI)
Reseat Pressure	90% of crack pressure
Leakage at 150 SSU (32 cSt)	5 drops/min. (.33 cc/min.) @75% of crack pressure
Cartridge Material	All parts steel. All operating parts hardened steel.
Operating Temp. Range/Seals	-37°C to +93°C (“D”-Ring) (-35°F to +200°F) -34°C to +121°C (Nitrile) (-30°F to +250°F) -26°C to +204°C (Fluorocarbon) (-15°F to +400°F)
Fluid Compatibility/Viscosity	Mineral-based or synthetic with lubricating properties at viscosities of 45 to 2000 SSU (6 to 420 cSt)
Filtration	ISO-4406 18/16/13, SAE Class 4
Approx. Weight	0.09 kg (0.20 lbs.)
Cavity	C08-2 (See BC Section for more details)

Performance Curve

Flow vs. Inlet Pressure
(Pressure rise through cartridge only)

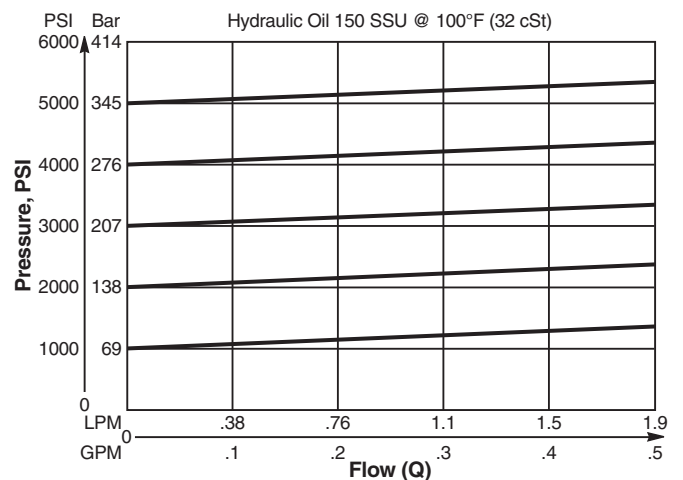

CV
Check Valves

SH
Shuttle Valves

LM
Load/Motor Controls

FC
Flow Controls

PC
Pressure Controls

LE
Logic Elements

DC
Directional Controls

SV
Solenoid Valves

PV
Proportional Valves

CE
Coils & Electronics

BC
Bodies & Cavities

TD
Technical Data

Dimensions Millimeters (Inches)

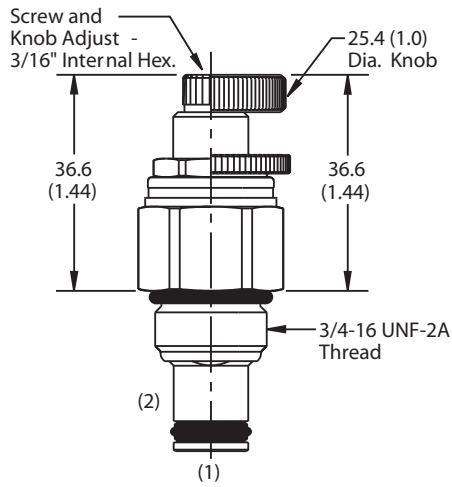

Screw/Knob Version

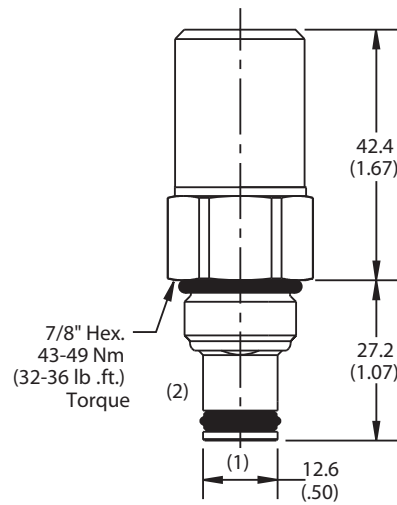

Tamper Resistant Version

Ordering Information

RDH081	S	<input type="checkbox"/>
08 Size Direct Acting Relief Valve	Adjustment Style	Pressure Range

Highlighted represents preferred options that offer the shortest lead times. Other options may be available, but at extended lead times.

Code	Adjustment Style
S	Screw Adjust

Code	Seals
Omit	D-Ring

Order Bodies Separately
 See section BC

B08	—	2	—	6T
08 size		2-Way Cavity		Port Size

Code	Porting / Body Material
6T	SAE-6 / Steel (5000 PSI)

Code	Pressure Range
10	6.9 - 69 Bar (100 - 1000 PSI) Standard Setting: 34.5 Bar (500 PSI) @ crack pressure, approximately 100 cc/min (6.1 in ³ /min)
30	13.8 - 207 Bar (200 - 3000 PSI) Standard Setting: 103.5 Bar (1500 PSI) @ crack pressure, approximately 100 cc/min (6.1 in ³ /min)
50	13.8 - 345 Bar (200 - 5000 PSI) Standard Setting: 172.4 Bar (2500 PSI) @ crack pressure, approximately 100 cc/min (6.1 in ³ /min)

Kit	Part Number
Knob	717784-10
Tamper Resistant Cap	717943
D-Ring Seal	SK08-2
Nitrile Seal	SK08-2
Fluorocarbon Seal	SK08-2V

CV
Check Valves
SH
Shuttle Valves
LM
Load/Motor Controls
FC
Flow Controls
PC
Pressure Controls
LE
Logic Elements
DC
Directional Controls
SV
Solenoid Valves
PV
Proportional Valves
CE
Coils & Electronics
BC
Bodies & Cavities
TD
Technical Data

General Description

Direct Acting Poppet-Type Relief Valve.
 For additional information see Technical Tips on pages PC3-PC7.

Features

- Hardened, precision ground parts for durability
- Fast response
- Spherical poppets for low leakage
- Internal mechanical stop limits poppet travel eliminating spring solidification
- All external parts zinc plated
- Polyurethane “D”-Ring eliminates backup rings and prevents hydrolysis

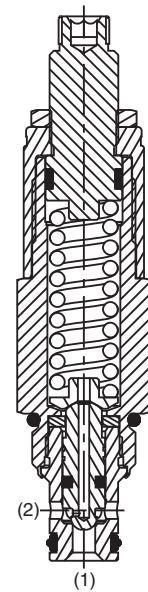
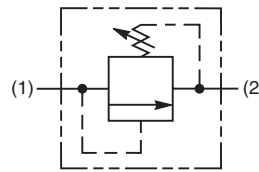

Specifications

Rated Flow	30 LPM (8 GPM)
Maximum Inlet Pressure	380 Bar (5500 PSI)
Maximum Pressure Setting	350 Bar (5000 PSI)
Sensitivity: Pressure/Turn	15 19.3 Bar (280 PSI) 30 35 Bar (508 PSI) 50 54 Bar (787 PSI)
Reseat Pressure	85% of crack pressure
Leakage at 150 SSU (32 cSt)	5 drops/min. (.33 cc/min.) @75% of crack pressure
Cartridge Material	All parts steel. All operating parts hardened steel.
Operating Temp. Range/Seals	-37°C to +93°C (“D”-Ring) (-35°F to +200°F) -34°C to +121°C (Nitrile) (-30°F to +250°F) -26°C to +204°C (Fluorocarbon) (-15°F to +400°F)
Fluid Compatibility/Viscosity	Mineral-based or synthetic with lubricating properties at viscosities of 45 to 2000 SSU (6 to 420 cSt)
Filtration	ISO-4406 18/16/13, SAE Class 4
Approx. Weight	0.18 kg (0.40 lbs.)
Cavity	C08-2 (See BC Section for more details)

Performance Curve

Flow vs. Inlet Pressure
 (Pressure rise through cartridge only)

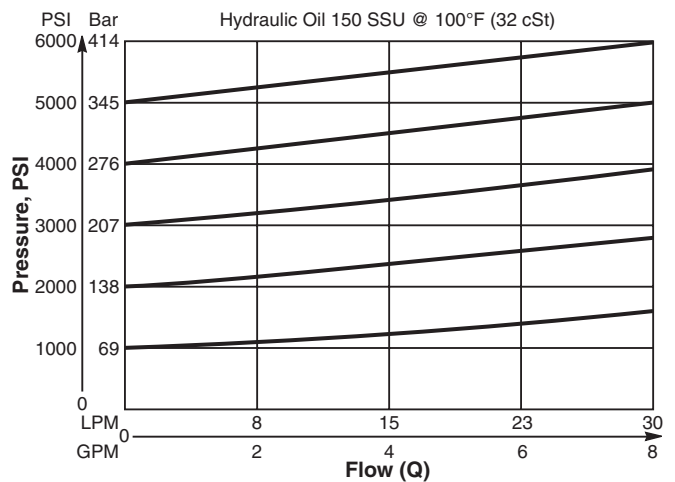

CV
Check Valves

SH
Shuttle Valves

LM
Load/Motor Controls

FC
Flow Controls

PC
Pressure Controls

LE
Logic Elements

DC
Directional Controls

SV
Solenoid Valves

PV
Proportional Valves

CE
Coils & Electronics

BC
Bodies & Cavities

TD
Technical Data

Dimensions Millimeters (Inches)

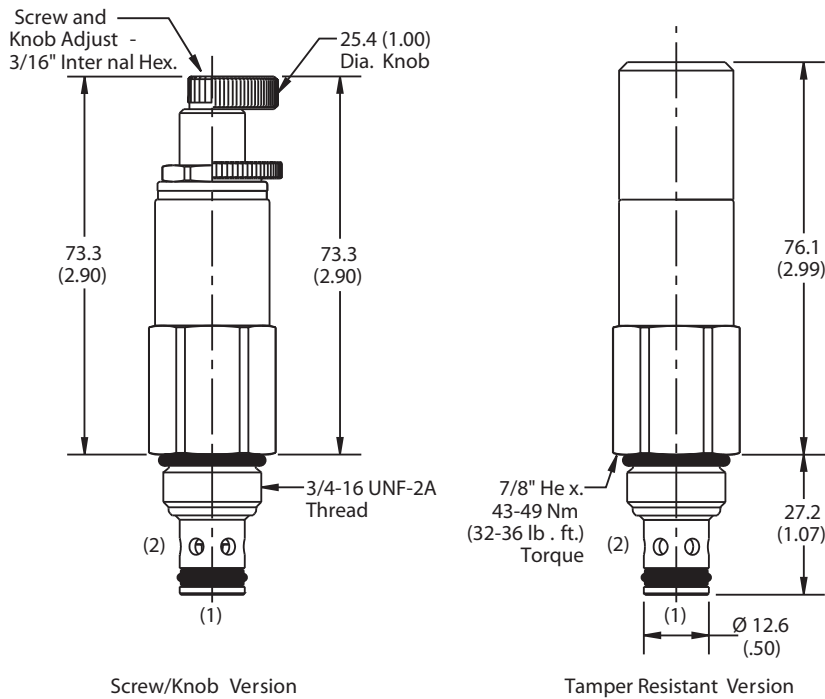

Ordering Information

RDH082	S	<input type="checkbox"/>
08 Size Direct Acting Relief Valve	Adjustment Style	Pressure Range

Highlighted represents preferred options that offer the shortest lead times. Other options may be available, but at extended lead times.

Code	Adjustment Style
S	Screw Adjust

Code	Seals
Omit	D-Ring

*Order Bodies Separately
 See section BC*

B08	—	2	—	6T
08 size		2-Way Cavity		Port Size

Code	Porting / Body Material
6T	SAE-6 / Steel (5000 PSI)

Code	Pressure Range
15	6.9 - 103 Bar (100 - 1500 PSI) Standard Setting: 51.7 Bar (750 PSI) @ crack pressure approximately .95 LPM (.25 GPM)
30	17.2 - 207 Bar (250 - 3000 PSI) Standard Setting: 103 Bar (1500 PSI) @ crack pressure approximately .95 LPM (.25 GPM)
50	34.5 - 345 Bar (500 - 5000 PSI) Standard Setting: 172.4 Bar (2500 PSI) @ crack pressure approximately .95 LPM (.25 GPM)

Kit	Part Number
Knob	717784-10
Tamper Resistant Cap	717943
D-Ring Seal	SK08-2
Nitrile Seal	SK08-2
Fluorocarbon Seal	SK08-2V

CV
Check Valves
SH
Shuttle Valves
LM
Load/Motor Controls
FC
Flow Controls
PC
Pressure Controls
LE
Logic Elements
DC
Directional Controls
SV
Solenoid Valves
PV
Proportional Valves
CE
Coils & Electronics
BC
Bodies & Cavities
TD
Technical Data

General Description

Direct Acting Relief Valve. This valve is designed for pilot flow circuits. For additional information see Technical Tips on pages PC3-PC7.

Features

- Hardened, precision ground parts for durability
- Low profile adapter for minimal space requirements
- Fully guided poppet for more consistent reseal
- Steel adapters are zinc plated
- Polyurethane “D”-Ring eliminates backup rings and prevents hydrolysis

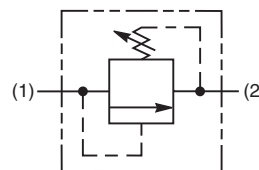
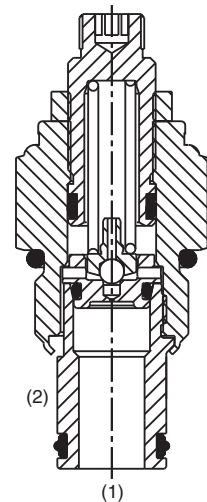

Specifications

Rated Flow	1.9 LPM (0.5 GPM)
Maximum Inlet Pressure	380 Bar (5500 PSI)
Maximum Pressure Setting	350 Bar (5000 PSI)
Sensitivity: Pressure/Turn	10 19.6 Bar (285 PSI) 30 58.9 Bar (859 PSI) 50 131.7 Bar (1910 PSI)
Reseat Pressure	90% of crack pressure
Leakage at 150 SSU (32 cSt)	5 drops/min. (.33 cc/min.) @75% of crack pressure
Cartridge Material	All parts steel. All operating parts hardened steel.
Operating Temp. Range/Seals	-37°C to +93°C (“D”-Ring) (-35°F to +200°F) -34°C to +121°C (Nitrile) (-30°F to +250°F) -26°C to +204°C (Fluorocarbon) (-15°F to +400°F)
Fluid Compatibility/Viscosity	Mineral-based or synthetic with lubricating properties at viscosities of 45 to 2000 SSU (6 to 420 cSt)
Filtration	ISO-4406 18/16/13, SAE Class 4
Approx. Weight	0.18 kg (0.40 lbs.)
Cavity	C10-2 (See BC Section for more details)

Performance Curve

Flow vs. Inlet Pressure
 (Pressure rise through cartridge only)

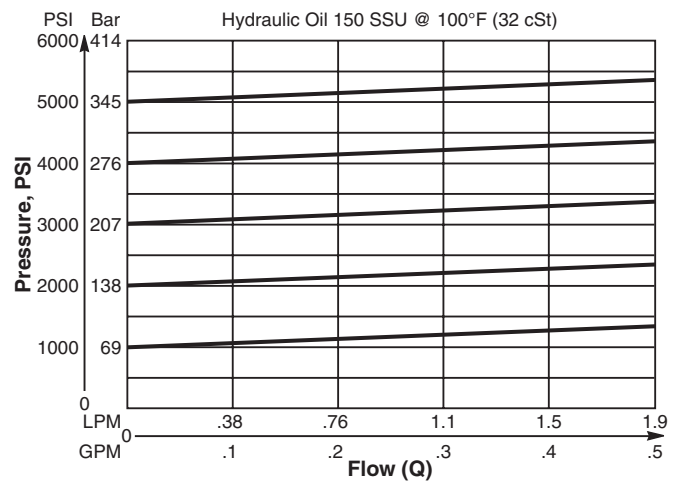

CV
Check Valves

SH
Shuttle Valves

LM
Load/Motor Controls

FC
Flow Controls

PC
Pressure Controls

LE
Logic Elements

DC
Directional Controls

SV
Solenoid Valves

PV
Proportional Valves

CE
Coils & Electronics

BC
Bodies & Cavities

TD
Technical Data

Dimensions Millimeters (Inches)

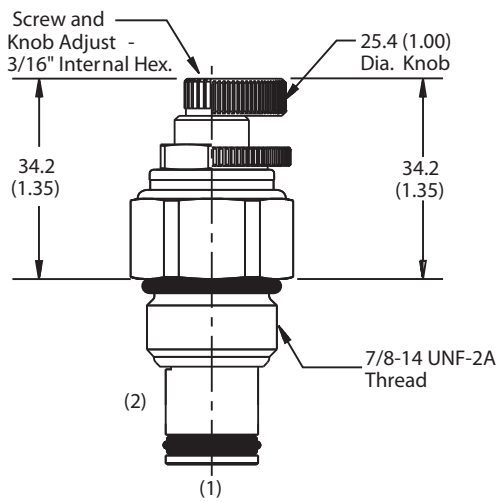

Screw/Knob Version

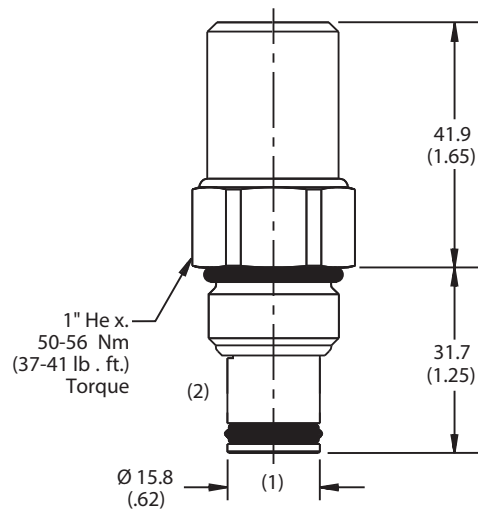

Tamper Resistant Version

Ordering Information

RDH101	S	□
10 Size Direct Acting Relief Valve	Adjustment Style	Pressure Range

Highlighted represents preferred options that offer the shortest lead times. Other options may be available, but at extended lead times.

Code	Adjustment Style
S	Screw Adjust

Code	Seals
Omit	D-Ring

Order Bodies Separately
 See section BC

B10	—	2	—	8T
10 size		2-Way Cavity		Port Size

Code	Porting / Body Material
8T	SAE-8 / Steel (5000 PSI)

Code	Pressure Range
10	6.9 - 69 Bar (100 - 1000 PSI) Standard Setting: 34.5 Bar (500 PSI) @ crack pressure, approximately 100 cc/min (6.1 in ³ /min)
30	13.8 - 207 Bar (200 - 3000 PSI) Standard Setting: 103.5 Bar (1500 PSI) @ crack pressure, approximately 100 cc/min (6.1 in ³ /min)
50	13.8 - 345 Bar (200 - 5000 PSI) Standard Setting: 172.4 Bar (2500 PSI) @ crack pressure, approximately 100 cc/min (6.1 in ³ /min)

Kit	Part Number
Knob	717784-10
Tamper Resistant Cap	718083
D-Ring Seal	SK10-2
Nitrile Seal	SK10-2
Fluorocarbon Seal	SK10-2V

CV	Check Valves
SH	Shuttle Valves
LM	Load/Motor Controls
FC	Flow Controls
PC	Pressure Controls
LE	Logic Elements
DC	Directional Controls
SV	Solenoid Valves
PV	Proportional Valves
CE	Coils & Electronics
BC	Bodies & Cavities
TD	Technical Data

General Description

Direct Acting Poppet-Type Relief Valve.
 For additional information see Technical Tips on pages PC3-PC7.

Features

- Hardened, precision ground parts for durability
- Internal mechanical stop limits poppet travel eliminating spring solidification
- Spherical poppets for low leakage
- “D”-Ring eliminates backup rings
- All external parts zinc plated
- Fast response

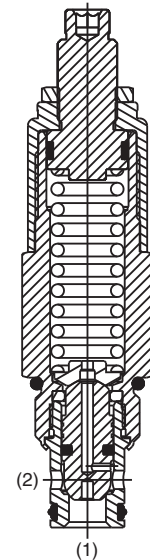
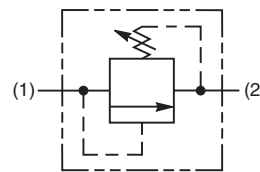

Specifications

Rated Flow	38 LPM (10 GPM)
Maximum Inlet Pressure	250 Bar (3600 PSI)
Maximum Pressure Setting	210 Bar (3000 PSI)
Sensitivity: Pressure/Turn	09 7.2 Bar (104 PSI) 18 16 Bar (234 PSI) 30 103.4 Bar (1500 PSI)
Maximum Tank Pressure	210 Bar (3000 PSI)
Reseat Pressure	85% of crack pressure
Leakage at 150 SSU (32 cSt)	5 drops/min. (.33 cc/min.) @75% of crack pressure
Cartridge Material	All parts steel. All operating parts hardened steel.
Operating Temp. Range/Seals	-37°C to +93°C (“D”-Ring) (-35°F to +200°F) -34°C to +121°C (Nitrile) (-30°F to +250°F) -26°C to +204°C (Fluorocarbon) (-15°F to +400°F)
Fluid Compatibility/Viscosity	Mineral-based or synthetic with lubricating properties at viscosities of 45 to 2000 SSU (6 to 420 cSt)
Filtration	ISO-4406 18/16/13, SAE Class 4
Approx. Weight	0.23 kg (0.5 lbs.)
Cavity	C10-2 (See BC Section for more details)

Performance Curve

Flow vs. Inlet Pressure
 (Pressure rise through cartridge only)

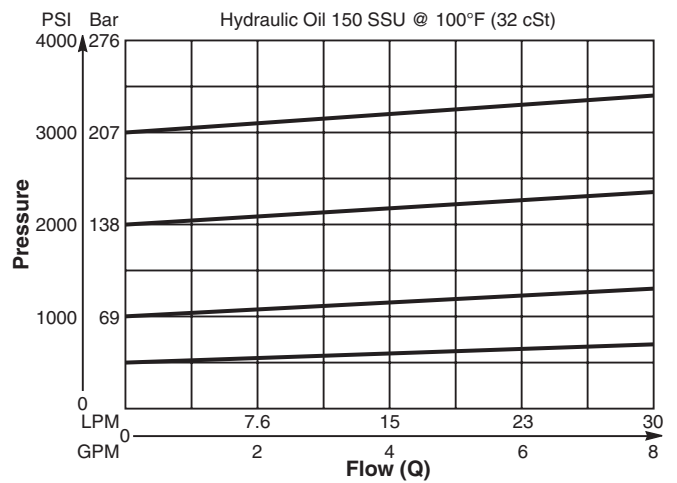

CV
Check Valves

SH
Shuttle Valves

LM
Load/Motor Controls

FC
Flow Controls

PC
Pressure Controls

LE
Logic Elements

DC
Directional Controls

SV
Solenoid Valves

PV
Proportional Valves

CE
Coils & Electronics

BC
Bodies & Cavities

TD
Technical Data

Dimensions Millimeters (Inches)

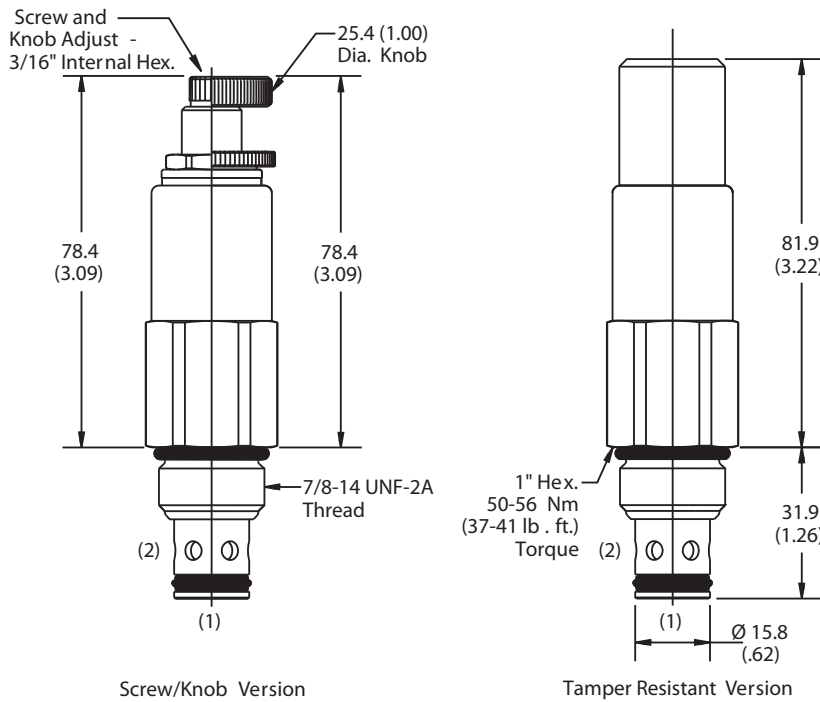

Ordering Information

RD102	S	□
10 Size Direct Acting Relief Valve	Adjustment Style	Pressure Range

Highlighted represents preferred options that offer the shortest lead times. Other options may be available, but at extended lead times.

Code	Adjustment Style
S	Screw Adjust

Code	Seals
Omit	D-Ring

Code	Pressure Range
09	7 - 62 Bar (100 - 900 PSI) Standard Setting: 31.0 Bar (450 PSI) @ .95 LPM (.25 GPM)
18	13.8 - 124 Bar (200 - 1800 PSI) Standard Setting: 62.1 Bar (900 PSI) @ .95 LPM (.25 GPM)
30	41.4 - 207 Bar (600 - 3000 PSI) Standard Setting: 103.4 Bar (1500 PSI) @ .95 LPM (.25 GPM)

Kit	Part Number
Knob	717784-10
Tamper Resistant Cap	717943
D-Ring Seal	SK10-2
Nitrile Seal	SK10-2
Fluorocarbon Seal	SK10-2V

Order Bodies Separately
 See section BC

B10	—	2	—	8T
10 size		2-Way Cavity		Port Size

Code	Porting / Body Material
8T	SAE-8 / Steel (5000 PSI)

CV
Check Valves
SH
Shuttle Valves
LM
Load/Motor Controls
FC
Flow Controls
PC
Pressure Controls
LE
Logic Elements
DC
Directional Controls
SV
Solenoid Valves
PV
Proportional Valves
CE
Coils & Electronics
BC
Bodies & Cavities
TD
Technical Data

General Description

Direct Acting Poppet-Type Relief Valve.
 For additional information see Technical Tips on pages PC3-PC7.

Features

- Fast response with good stability
- Virtually leak free
- Hardened working parts for maximum durability
- All external parts zinc plated

Specifications

Rated Flow	100 LPM (26 GPM)
Maximum Inlet Pressure	H- 5-210 Bar (72-3000 PSI) P- 5-420 Bar (72-6000 PSI)
Maximum Pressure Setting	420 Bar (6000 PSI)
Sensitivity: Pressure/Turn	H- 21 Bar (305 PSI) P- 43.4 Bar (630 PSI)
Maximum Tank Pressure	420 Bar (6000 PSI)
Leakage at 150 SSU (32 cSt)	5 drops/min. @100 Bar (1450 PSI)
Cartridge Material	All parts steel. All operating parts hardened steel.
Operating Temp. Range/Seals	-34°C to +121°C (Nitrile) (-30°F to +250°F) -26°C to +204°C (Fluorocarbon) (-15°F to +400°F)
Fluid Compatibility/Viscosity	Mineral-based or synthetic with lubricating properties at viscosities of 45 to 2000 SSU (6 to 420 cSt)
Filtration	ISO-4406 18/16/13, SAE Class 4
Approx. Weight	0.28 kg (0.62 lbs.)
Cavity	C10-2 (See BC Section for more details)

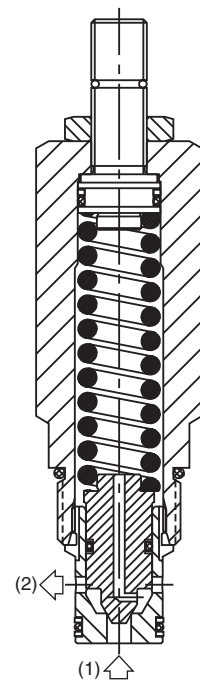
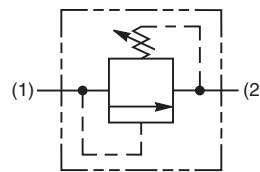

Performance Curves

(Pressure rise through cartridge only)

Flow vs. Inlet Pressure

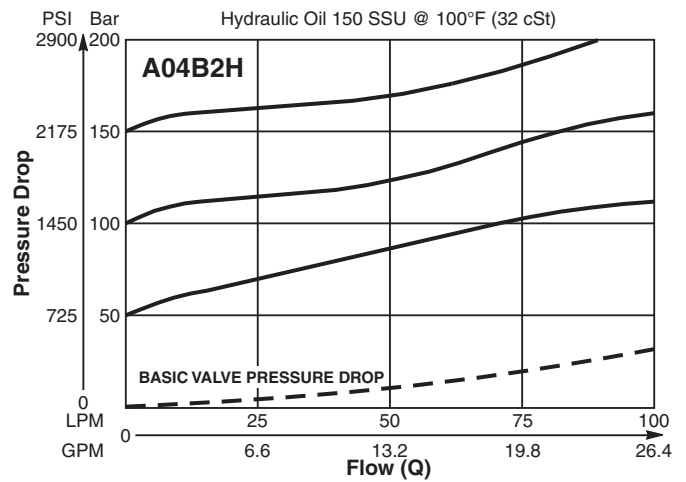

Flow vs. Inlet Pressure

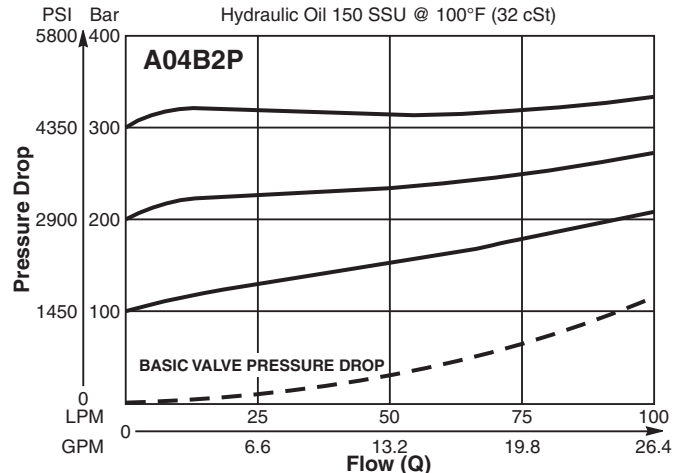

CV
Check Valves

SH
Shuttle Valves

LM
Load/Motor Controls

FC
Flow Controls

PC
Pressure Controls

LE
Logic Elements

DC
Directional Controls

SV
Solenoid Valves

PV
Proportional Valves

CE
Coils & Electronics

BC
Bodies & Cavities

TD
Technical Data

Dimensions Millimeters (Inches)

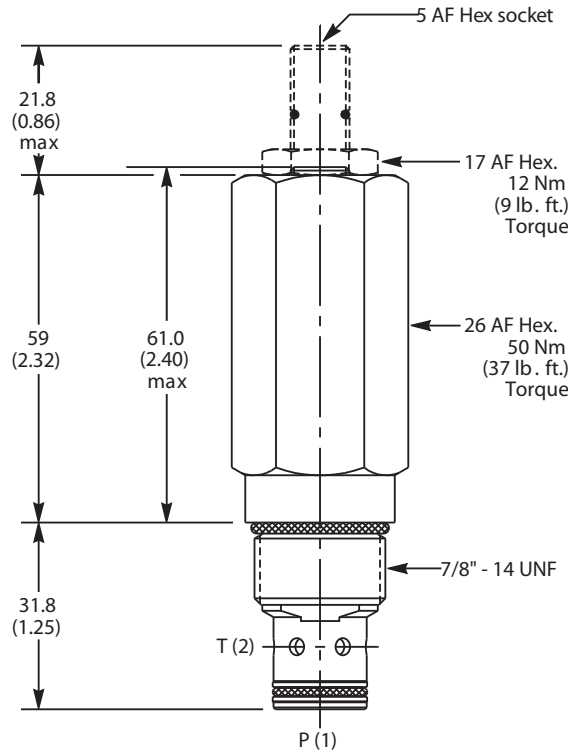

Ordering Information

A04B2		Z	N
10 Size Direct Acting Relief Valve	Pressure Adjustment Range	Adjustment Style	Seals

Highlighted represents preferred options that offer the shortest lead times. Other options may be available, but at extended lead times.

Code	Pressure Range
H	5 - 210 Bar (72 - 3000 PSI)
P	5 - 420 Bar (72 - 6000 PSI)

Code	Adjustment Style
Z	Screw Adjust

Code	Seals
N	Nitrile

Standard Pressure Setting
A04B2H Standard Setting: 100 Bar (1450 PSI) @ 15 LPM (4.0 GPM)
A04B2P Standard Setting: 200 Bar (2900 PSI) @ 15 LPM (4.0 GPM)

Order Bodies Separately
 See section BC

B10	—	2	—	8T
10 size		2-Way Cavity		Port Size

Code	Porting / Body Material
8T	SAE-8 / Steel (5000 PSI)

Kit	Part Number
Knob	ASV014975
Tamper Resistant Cap	TC1130
Nitrile Seal	SK30503N-1
Fluorocarbon Seal	SK30503V-1

CV	Check Valves
SH	Shuttle Valves
LM	Load/Motor Controls
FC	Flow Controls
PC	Pressure Controls
LE	Logic Elements
DC	Directional Controls
SV	Solenoid Valves
PV	Proportional Valves
CE	Coils & Electronics
BC	Bodies & Cavities
TD	Technical Data

General Description

Differential Area Relief Valve.
 For additional information see Technical Tips on pages PC3-PC7.

Features

- Hardened, precision ground parts for durability
- Spherical poppets for low leakage
- High flow capacity
- Internal mechanical stop limits poppet travel eliminating spring solidification
- All external parts zinc plated

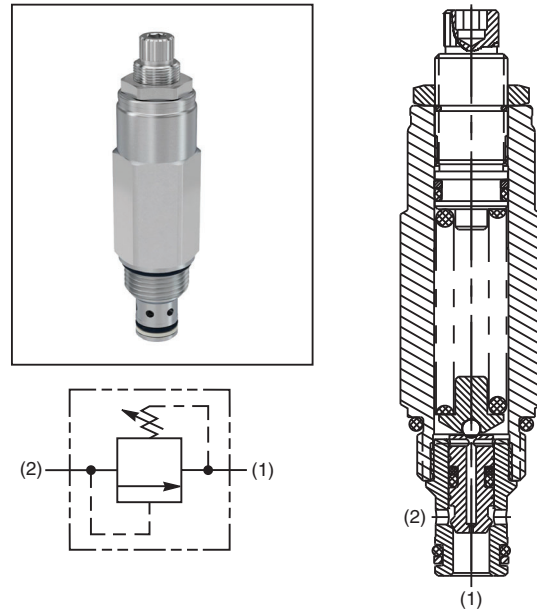

Specifications

Rated Flow	45 LPM (12 GPM)
Maximum Inlet Pressure	380 Bar (5500 PSI)
Maximum Pressure Setting	350 Bar (5000 PSI)
Sensitivity: Pressure/Turn	15 15 Bar (218 PSI) 30 27 Bar (396 PSI) 50 42 Bar (614 PSI)
Maximum Tank Pressure	350 Bar (5000 PSI)
Reseat Pressure	75% of crack pressure
Leakage at 150 SSU (32 cSt)	10 drops/min. (.67 cc/min.) @75% of crack pressure
Cartridge Material	All parts steel. All operating parts hardened steel.
Operating Temp. Range/Seals	-34°C to +121°C (Nitrile) (-30°F to +250°F) -26°C to +204°C (Fluorocarbon) (-15°F to +400°F)
Fluid Compatibility/Viscosity	Mineral-based or synthetic with lubricating properties at viscosities of 45 to 2000 SSU (6 to 420 cSt)
Filtration	ISO-4406 18/16/13, SAE Class 4
Approx. Weight	0.19 kg (0.43 lbs.)
Cavity	C08-2 (See BC Section for more details)

Performance Curve

Flow vs. Inlet Pressure
 (Pressure rise through cartridge only)

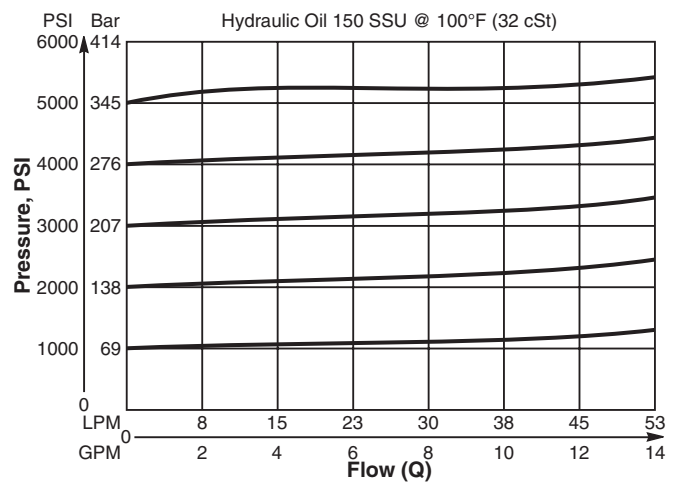

CV
Check Valves

SH
Shuttle Valves

LM
Load/Motor Controls

FC
Flow Controls

PC
Pressure Controls

LE
Logic Elements

DC
Directional Controls

SV
Solenoid Valves

PV
Proportional Valves

CE
Coils & Electronics

BC
Bodies & Cavities

TD
Technical Data

Dimensions Millimeters (Inches)

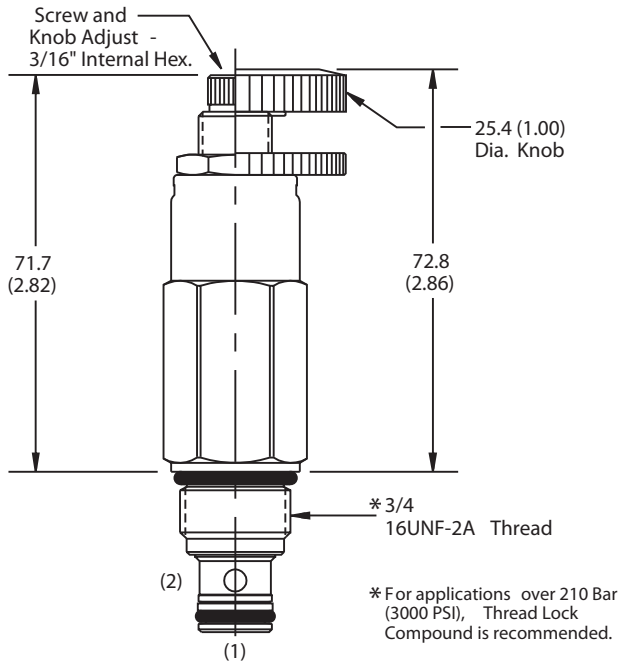

Screw/Knob Version

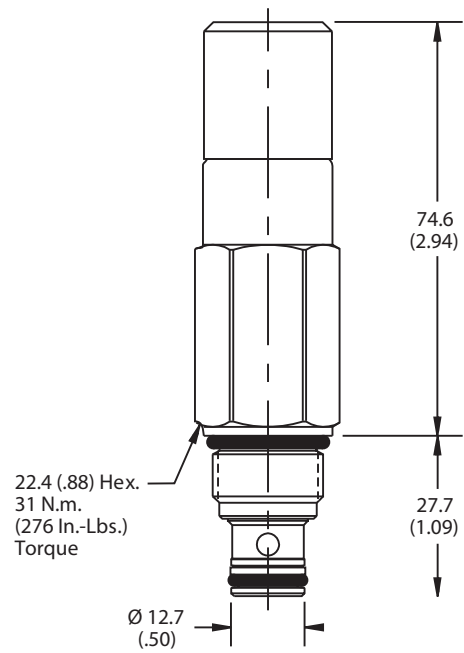

Tamper Resistant Version

* 3/4 16UNF-2A Thread
 * For applications over 210 Bar (3000 PSI), Thread Lock Compound is recommended.

Ordering Information

RDH083	S	□
08 Size Differential Area Relief Valve	Adjustment Style	Pressure Range

Highlighted represents preferred options that offer the shortest lead times. Other options may be available, but at extended lead times.

Code	Adjustment Style
S	Screw Adjust

Code	Seals
Omit	Nitrile

Order Bodies Separately
 See section BC

B08	-	2	-	6T
08 size		2-Way Cavity		Port Size

Code	Porting / Body Material
6T	SAE-6 / Steel (5000 PSI)

Code	Pressure Range
15	6.9 - 103 Bar (100 - 1500 PSI) Standard Setting: 51.7 Bar (750 PSI) @ crack pressure approximately .95 LPM (.25 GPM)
30	69 - 207 Bar (1000 - 3000 PSI) Standard Setting: 103 Bar (1500 PSI) @ crack pressure approximately .95 LPM (.25 GPM)
50	138 - 345 Bar (2000 - 5000 PSI) Standard Setting: 172.4 Bar (2500 PSI) @ crack pressure approximately .95 LPM (.25 GPM)

Kit	Part Number
Knob	717784-10
Tamper Resistant Cap	718083
Nitrile Seal	SK08-2
Fluorocarbon Seal	SK08-2V



CV	Check Valves
SH	Shuttle Valves
LM	Load/Motor Controls
FC	Flow Controls
PC	Pressure Controls
LE	Logic Elements
DC	Directional Controls
SV	Solenoid Valves
PV	Proportional Valves
CE	Coils & Electronics
BC	Bodies & Cavities
TD	Technical Data

General Description

Differential Area Relief Valve.
 For additional information see Technical Tips on pages PC3-PC7.

Features

- Hardened, precision ground parts for durability
- Internal mechanical stop limits poppet travel eliminating spring solidification
- Spherical poppets for low leakage
- “D”-Ring eliminates backup rings
- All external parts zinc plated
- High flow capacity

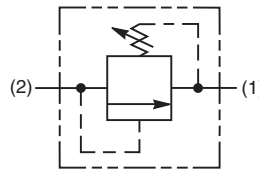
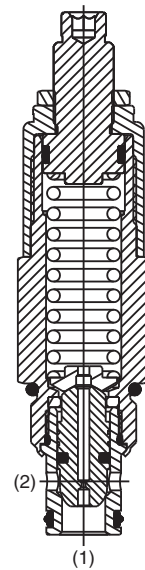

Specifications

Rated Flow	75 LPM (20 GPM)
Maximum Inlet Pressure	380 Bar (5500 PSI)
Maximum Pressure Setting	350 Bar (5000 PSI)
Sensitivity: Pressure/Turn	10 9.8 Bar (143 PSI) 30 25.8 Bar (375 PSI) 50 40.6 Bar (589 PSI)
Reseat Pressure	85% of crack pressure
Leakage at 150 SSU (32 cSt)	5 drops/min. (.33 cc/min.) @75% of crack pressure
Cartridge Material	All parts steel. All operating parts hardened steel.
Operating Temp. Range/Seals	-37°C to +93°C (“D”-Ring) (-35°F to +200°F) -34°C to +121°C (Nitrile) (-30°F to +250°F) -26°C to +204°C (Fluorocarbon) (-15°F to +400°F)
Fluid Compatibility/Viscosity	Mineral-based or synthetic with lubricating properties at viscosities of 45 to 2000 SSU (6 to 420 cSt)
Filtration	ISO-4406 18/16/13, SAE Class 4
Approx. Weight	0.23 kg (0.50 lbs.)
Cavity	C10-2 (See BC Section for more details)

Performance Curve

Flow vs. Inlet Pressure
 (Pressure rise through cartridge only)

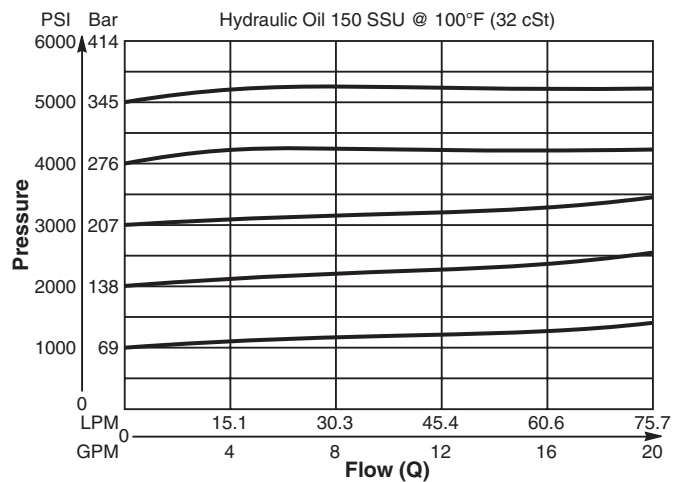

CV
Check Valves

SH
Shuttle Valves

LM
Load/Motor Controls

FC
Flow Controls

PC
Pressure Controls

LE
Logic Elements

DC
Directional Controls

SV
Solenoid Valves

PV
Proportional Valves

CE
Coils & Electronics

BC
Bodies & Cavities

TD
Technical Data

Dimensions Millimeters (Inches)

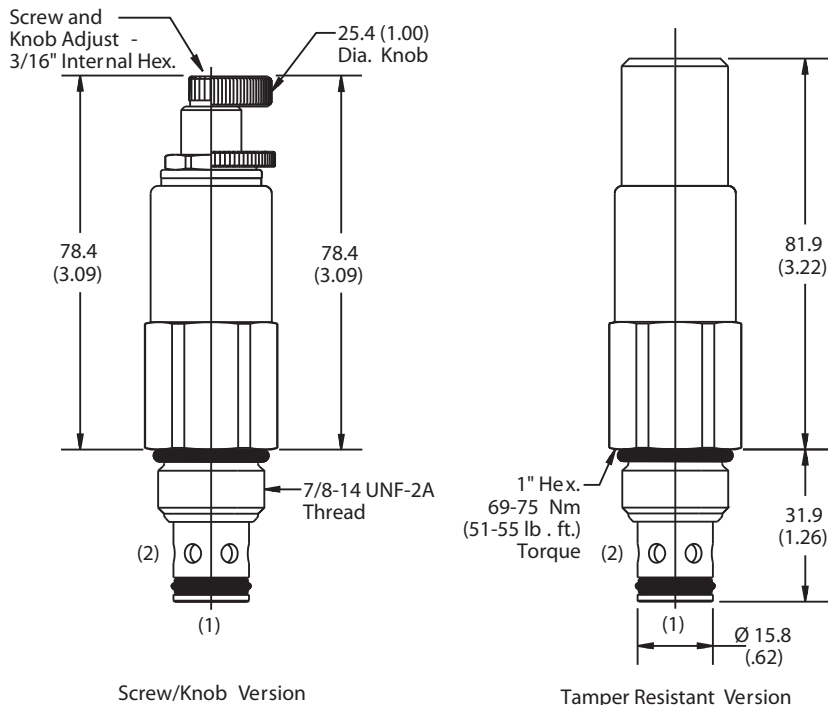

Ordering Information

RDH103	S	□
10 Size Differential Area Relief Valve	Adjustment Style	Pressure Range

Highlighted represents preferred options that offer the shortest lead times. Other options may be available, but at extended lead times.

Code	Adjustment Style
S	Screw Adjust

Code	Seals
Omit	D-Ring

Order Bodies Separately
 See section BC

B10	-	2	-	8T
10 size		2-Way Cavity		Port Size

Code	Porting / Body Material
8T	SAE-8 / Steel (5000 PSI)

Code	Pressure Range
10	6.9 - 69 Bar (100 - 1000 PSI) Standard Setting: 34.5 Bar (500 PSI) @ .95 LPM (.25 GPM)
30	34.5 - 207 Bar (500 - 3000 PSI) Standard Setting: 103.5 Bar (1500 PSI) @ .95 LPM (.25 GPM)
50	34.5 - 345 Bar (500 - 5000 PSI) Standard Setting: 172.4 Bar (2500 PSI) @ .95 LPM (.25 GPM)

Kit	Part Number
Knob	717784-10
Tamper Resistant Cap	717943
D-Ring Seal	SK10-2
Nitrile Seal	SK10-2
Fluorocarbon Seal	SK10-2V



CV
Check Valves
SH
Shuttle Valves
LM
Load/Motor Controls
FC
Flow Controls
PC
Pressure Controls
LE
Logic Elements
DC
Directional Controls
SV
Solenoid Valves
PV
Proportional Valves
CE
Coils & Electronics
BC
Bodies & Cavities
TD
Technical Data

General Description

Differential Area Relief Valve.
 For additional information see Technical Tips on pages PC3-PC7.

Features

- Hardened, precision ground parts for durability
- Compact size for reduced space requirements
- Low leakage design
- Fast response
- All external parts zinc plated

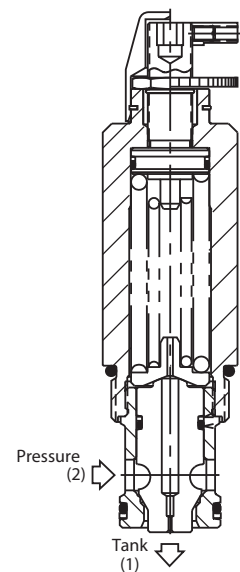
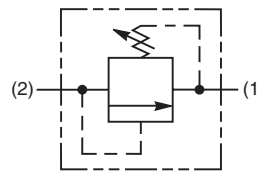

Specifications

Rated Flow	151 LPM (40 GPM)
Maximum Inlet Pressure	240 Bar (3500 PSI)
Maximum Pressure Setting	210 Bar (3000 PSI)
Sensitivity: Pressure/Turn	10 7 Bar (104 PSI) 30 14 Bar (204 PSI)
Maximum Tank Pressure	210 Bar (3000 PSI)
Reseat Pressure	80% of crack pressure
Leakage at 150 SSU (32 cSt)	10 drops/min. (.66 cc/min.) @75% of crack pressure
Cartridge Material	All parts steel. All operating parts hardened steel.
Operating Temp. Range/Seals	-34°C to +121°C (Nitrile) (-30°F to +250°F) -26°C to +204°C (Fluorocarbon) (-15°F to +400°F)
Fluid Compatibility/Viscosity	Mineral-based or synthetic with lubricating properties at viscosities of 45 to 2000 SSU (6 to 420 cSt)
Filtration	ISO-4406 18/16/13, SAE Class 4
Approx. Weight	0.23 kg (0.50 lbs.)
Cavity	C16-2 (See BC Section for more details)

Performance Curve

Flow vs. Inlet Pressure
 (Pressure rise through cartridge only)

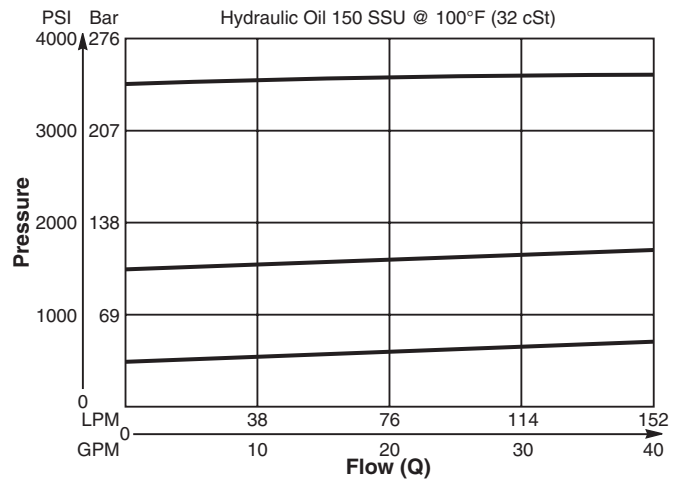

CV
Check Valves

SH
Shuttle Valves

LM
Load/Motor Controls

FC
Flow Controls

PC
Pressure Controls

LE
Logic Elements

DC
Directional Controls

SV
Solenoid Valves

PV
Proportional Valves

CE
Coils & Electronics

BC
Bodies & Cavities

TD
Technical Data

Dimensions

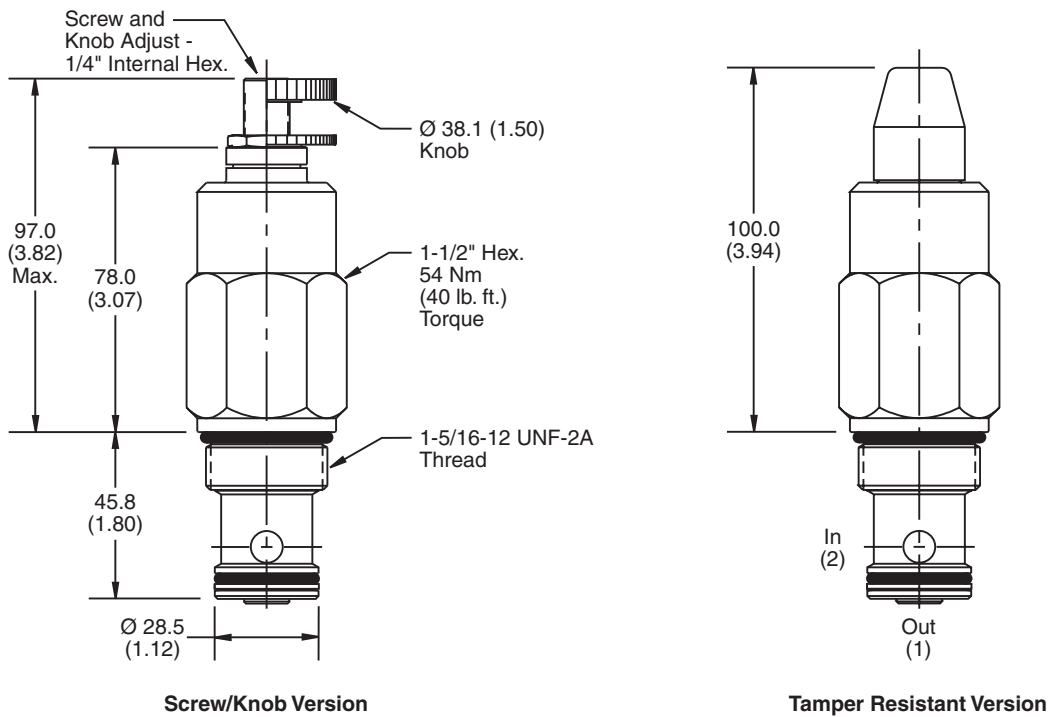

Ordering Information

RD163	S	□
16 Size Differential Area Relief Valve	Adjustment Style	Pressure Range

Highlighted represents preferred options that offer the shortest lead times. Other options may be available, but at extended lead times.

Code	Adjustment Style
S	Screw Adjust

Code	Seals
Omit	Nitrile

*Order Bodies Separately
 See section BC*

B16	—	2	—	16T
16 size		2-Way Cavity		Port Size

Code	Porting / Body Material
16T	SAE-16 / Steel (5000 PSI)

Code	Pressure Range
10	13.8 - 69 Bar (200 - 1000 PSI) Standard Setting: 34.5 Bar (500 PSI) @ 11.3 LPM (3 GPM)
30	41.4 - 207 Bar (600 - 3000 PSI) Standard Setting: 103.5 Bar (1500 PSI) @ 11.3 LPM (3 GPM)

Kit	Part Number
Knob	840208K
Tamper Resistant Cap	717783
Nitrile Seal	SK16-2
Fluorocarbon Seal	SK16-2V

CV
Check Valves
SH
Shuttle Valves
LM
Load/Motor Controls
FC
Flow Controls
PC
Pressure Controls
LE
Logic Elements
DC
Directional Controls
SV
Solenoid Valves
PV
Proportional Valves
CE
Coils & Electronics
BC
Bodies & Cavities
TD
Technical Data

General Description

Pilot Operated Spool-Type Relief Valve.
 For additional information see Technical Tips on pages PC3-PC7.

Features

- Hardened, precision ground parts for durability
- Low profile adapter for minimal space requirements
- Fully guided pilot for more consistent reseal
- Steel adapters are zinc plated
- Polyurethane “D”-Ring eliminates backup rings and prevents hydrolysis
- Internal screening protects pilot spring from debris

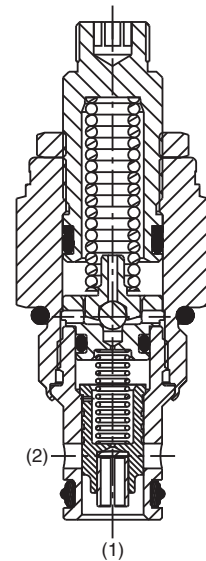
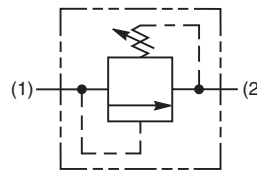

Specifications

Rated Flow	75.8 LPM (20 GPM)
Maximum Inlet Pressure	350 Bar (5000 PSI)
Maximum Pressure Setting	350 Bar (5000 PSI)
Sensitivity: Pressure/Turn	10 19.6 Bar (285 PSI) 30 58.9 Bar (859 PSI) 50 131.7 Bar (1910 PSI)
Maximum Tank Pressure	350 Bar (5000 PSI)
Reseat Pressure	90% of crack pressure
Leakage at 150 SSU (32 cSt)	5 cc per 6.8 Bar (100PSI) setting
Cartridge Material	All parts steel. All operating parts hardened steel.
Operating Temp. Range/Seals	-37°C to +93°C (“D”-Ring) (-35°F to +200°F) -34°C to +121°C (Nitrile) (-30°F to +250°F) -26°C to +204°C (Fluorocarbon) (-15°F to +400°F)
Fluid Compatibility/Viscosity	Mineral-based or synthetic with lubricating properties at viscosities of 45 to 2000 SSU (6 to 420 cSt)
Filtration	ISO-4406 18/16/13, SAE Class 4
Approx. Weight	0.09 kg (0.20 lbs.)
Cavity	C08-2 (See BC Section for more details)

Performance Curves

Flow vs. Inlet Pressure

(Pressure rise through cartridge only)

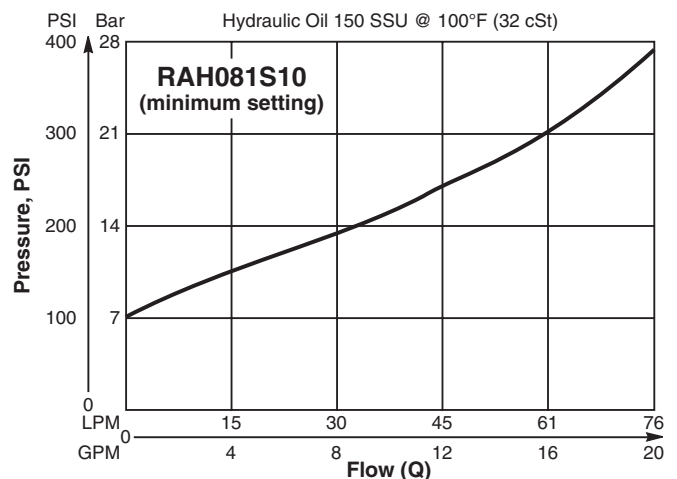
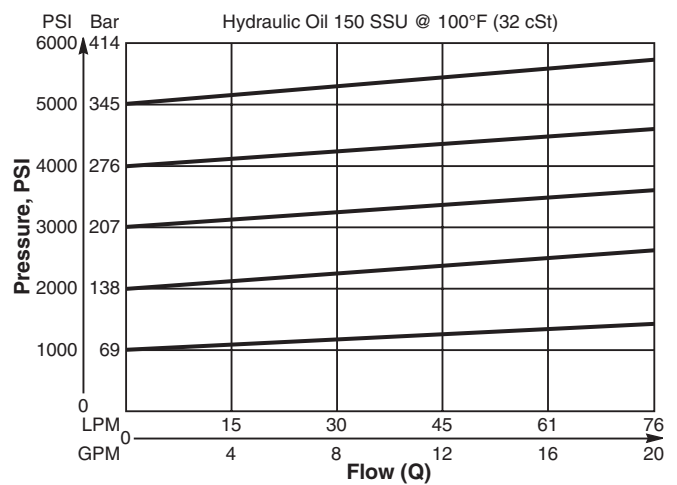

- CV
- Check Valves
- SH
- Shuttle Valves
- LM
- Load/Motor Controls
- FC
- Flow Controls
- PC
- Pressure Controls
- LE
- Logic Elements
- DC
- Directional Controls
- SV
- Solenoid Valves
- PV
- Proportional Valves
- CE
- Coils & Electronics
- BC
- Bodies & Cavities
- TD
- Technical Data

Dimensions Millimeters (Inches)

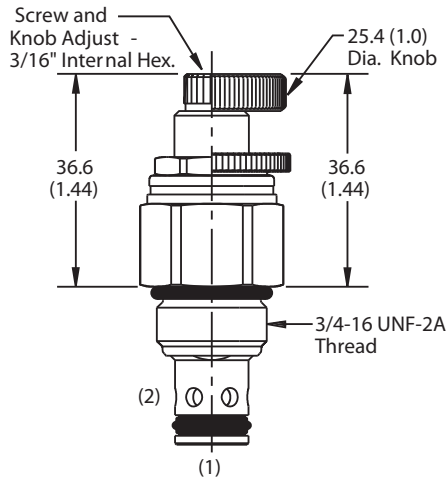

Screw/Knob Version

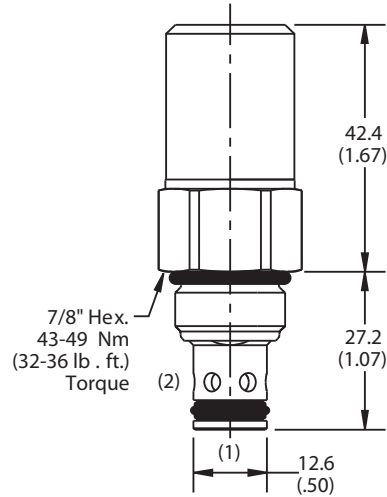

Tamper Resistant Version

Ordering Information

RAH081	S	<input type="checkbox"/>
08 Size Pilot Operated Relief Valve	Adjustment Style	Pressure Range

Highlighted represents preferred options that offer the shortest lead times. Other options may be available, but at extended lead times.

Code	Adjustment Style
S	Screw Adjust

Code	Seals
Omit	D-Ring

Order Bodies Separately
 See section BC

B08	—	2	—	6T
08 size		2-Way Cavity		Port Size

Code	Porting / Body Material
6T	SAE-6 / Steel (5000 PSI)

Code	Pressure Range
10	6.9 - 69 Bar (100 - 1000 PSI) Standard Setting: 34.5 Bar (500 PSI) @ crack pressure, approximately .95 LPM (.25 GPM)
30	13.8 - 207 Bar (200 - 3000 PSI) Standard Setting: 103.5 Bar (1500 PSI) @ crack pressure, approximately .95 LPM (.25 GPM)
50	13.8 - 345 Bar (200 - 5000 PSI) Standard Setting: 172.4 Bar (2500 PSI) @ crack pressure, approximately .95 LPM (.25 GPM)

Kit	Part Number
Knob	717784-10
Tamper Resistant Cap	717943
D-Ring Seal	SK08-2
Nitrile Seal	SK08-2
Fluorocarbon Seal	SK08-2V

CV	Check Valves
SH	Shuttle Valves
LM	Load/Motor Controls
FC	Flow Controls
PC	Pressure Controls
LE	Logic Elements
DC	Directional Controls
SV	Solenoid Valves
PV	Proportional Valves
CE	Coils & Electronics
BC	Bodies & Cavities
TD	Technical Data

General Description

Pilot Operated Spool-Type Relief Valve.
 For addition information see Technical Tips on pages PC3-PC7.

Features

- Hardened, precision ground parts for durability
- Low profile adapter for minimal space requirements
- Fully guided poppet for more consistent reseal
- Steel adapters are zinc plated
- Polyurethane “D”-Ring eliminates backup rings and prevents hydrolysis
- Internal screening protects pilot spring from debris

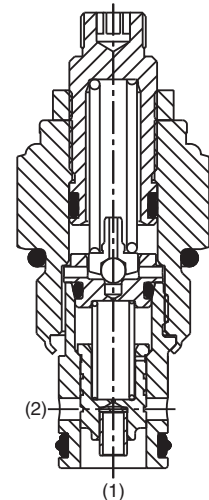
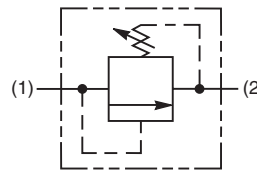

Specifications

Rated Flow	113 LPM (30 GPM)
Maximum Inlet Pressure	350 Bar (5000 PSI)
Maximum Pressure Setting	350 Bar (5000 PSI)
Sensitivity: Pressure/Turn	10 19.6 Bar (285 PSI) 30 58.9 Bar (859 PSI) 50 131.7 Bar (1910 PSI)
Maximum Tank Pressure	350 Bar (5000 PSI)
Reseat Pressure	90% of crack pressure
Leakage at 150 SSU (32 cSt)	5 cc per 6.8 Bar (100 PSI) setting
Cartridge Material	All parts steel. All operating parts hardened steel.
Operating Temp. Range/Seals	-37°C to +93°C (“D”-Ring) (-35°F to +200°F) -34°C to +121°C (Nitrile) (-30°F to +250°F) -26°C to +204°C (Fluorocarbon) (-15°F to +400°F)
Fluid Compatibility/Viscosity	Mineral-based or synthetic with lubricating properties at viscosities of 45 to 2000 SSU (6 to 420 cSt)
Filtration	ISO-4406 18/16/13, SAE Class 4
Approx. Weight	0.23 kg (0.50 lbs.)
Cavity	C10-2 (See BC Section for more details)

Performance Curves

Flow vs. Inlet Pressure

(Pressure rise through cartridge only)

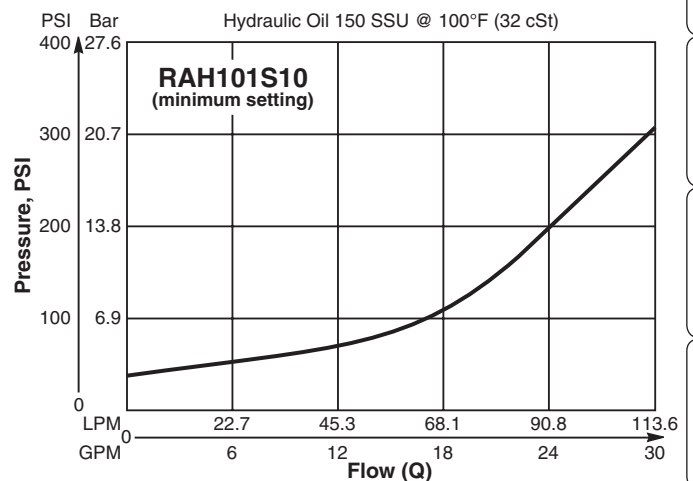
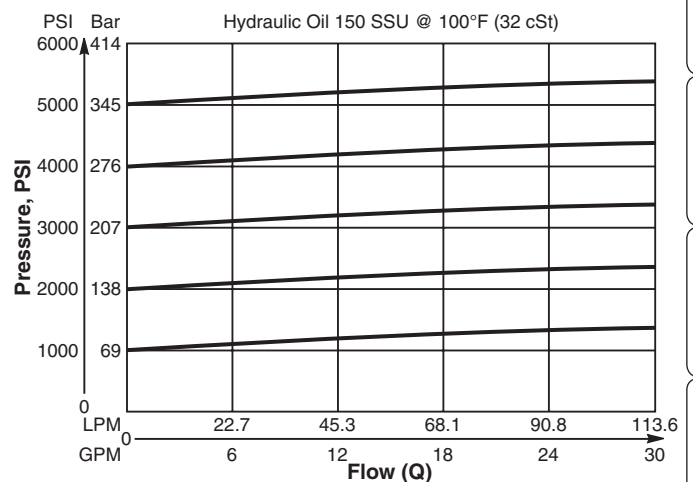

CV
Check Valves

SH
Shuttle Valves

LM
Load/Motor Controls

FC
Flow Controls

PC
Pressure Controls

LE
Logic Elements

DC
Directional Controls

SV
Solenoid Valves

PV
Proportional Valves

CE
Coils & Electronics

BC
Bodies & Cavities

TD
Technical Data

Dimensions Millimeters (Inches)

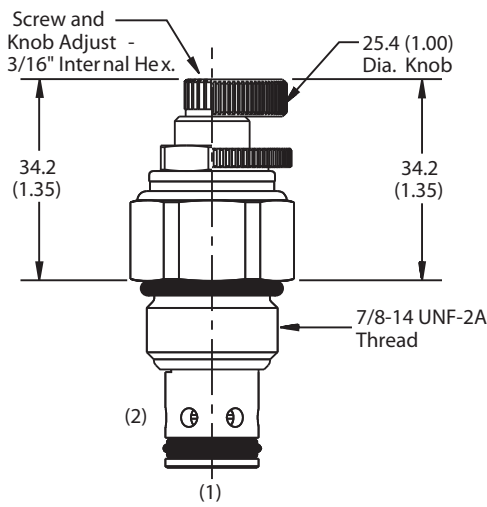

Screw/Knob Version

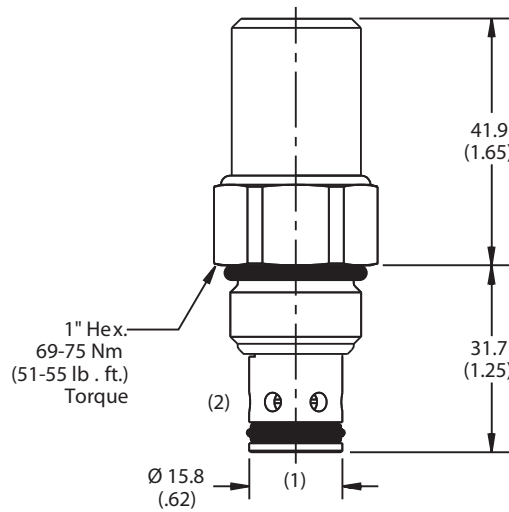

Tamper Resistant Version

Ordering Information

RAH101	S	
10 Size Pilot Operated Relief Valve	Adjustment Style	Pressure Range

Highlighted represents preferred options that offer the shortest lead times. Other options may be available, but at extended lead times.

Code	Adjustment Style
S	Screw Adjust

Code	Seals
Omit	D-Ring

Order Bodies Separately
 See section BC

B10	—	2	—	8T
10 size		2-Way Cavity		Port Size

Code	Porting / Body Material
8T	SAE-8 / Steel (5000 PSI)

Code	Pressure Range
10	6.9 - 69 Bar (100 - 1000 PSI) Standard Setting: 34.5 Bar (500 PSI) @ crack pressure, approximately .95 LPM (.25 GPM)
30	13.8 - 207 Bar (200 - 3000 PSI) Standard Setting: 103.5 Bar (1500 PSI) @ crack pressure, approximately .95 LPM (.25 GPM)
50	13.8 - 345 Bar (200 - 5000 PSI) Standard Setting: 172.4 Bar (2500 PSI) @ crack pressure, approximately .95 LPM (.25 GPM)

Kit	Part Number
Knob	717784-10
Tamper Resistant Cap	717083
D-Ring Seal	SK10-2
Nitrile Seal	SK10-2
Fluorocarbon Seal	SK10-2V

CV
Check Valves
SH
Shuttle Valves
LM
Load/Motor Controls
FC
Flow Controls
PC
Pressure Controls
LE
Logic Elements
DC
Directional Controls
SV
Solenoid Valves
PV
Proportional Valves
CE
Coils & Electronics
BC
Bodies & Cavities
TD
Technical Data

General Description

Pilot Operated Spool-Type Relief Valve.
 For additional information see Technical Tips on pages PC3-PC7.

Features

- Low override curve
- Ball-type pilot for added stability
- High accuracy - pilot operated design
- Hardened, precision ground parts for durability
- Compact size for reduced space requirements
- All external parts zinc plated

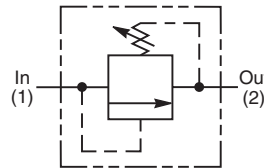
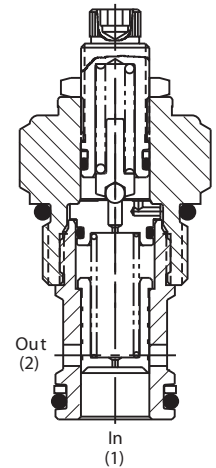

Specifications

Rated Flow	189.5 LPM (50 GPM)
Maximum Inlet Pressure	380 Bar (5500 PSI)
Maximum Pressure Setting	350 Bar (5000 PSI)
Sensitivity: Pressure/Turn	10 23 Bar (334 PSI) 30 59.7 Bar (867 PSI) 50 118 Bar (1711 PSI)
Reseat Pressure	80% of crack pressure
Leakage at 150 SSU (32 cSt)	82 cc/min. (5 cu. in./min.) @75% of crack pressure
Cartridge Material	All parts steel. All operating parts hardened steel.
Operating Temp. Range/Seals	-34°C to +121°C (Nitrile) (-30°F to +250°F) -26°C to +204°C (Fluorocarbon) (-15°F to +400°F)
Fluid Compatibility/Viscosity	Mineral-based or synthetic with lubricating properties at viscosities of 45 to 2000 SSU (6 to 420 cSt)
Filtration	ISO-4406 18/16/13, SAE Class 4
Approx. Weight	0.22 kg (0.48 lbs.)
Cavity	C12-2 (See BC Section for more details)

Performance Curve

Flow vs. Inlet Pressure
 (Pressure rise through cartridge only)

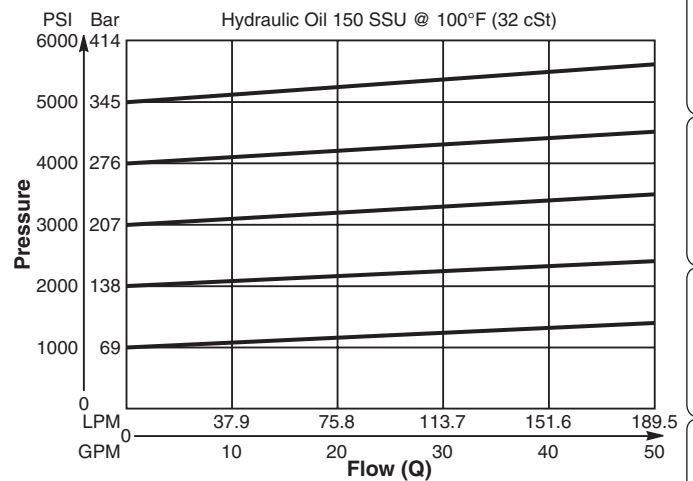

CV
Check Valves
SH
Shuttle Valves
LM
Load/Motor Controls
FC
Flow Controls
PC
Pressure Controls
LE
Logic Elements
DC
Directional Controls
SV
Solenoid Valves
PV
Proportional Valves
CE
Coils & Electronics
BC
Bodies & Cavities
TD
Technical Data

Dimensions Millimeters (Inches)

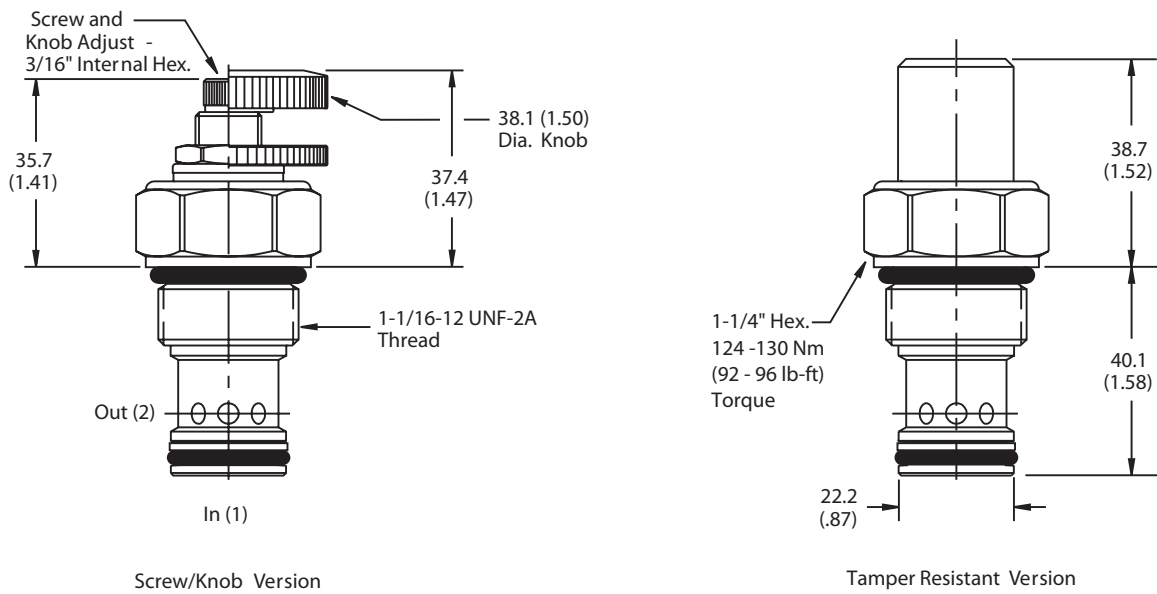

Ordering Information

RAH121	S	<input type="checkbox"/>
12 Size Pilot Operated Relief Valve	Adjustment Style	Pressure Range

Highlighted represents preferred options that offer the shortest lead times. Other options may be available, but at extended lead times.

Code	Adjustment Style
S	Screw Adjust

Code	Seals
Omit	Nitrile

Order Bodies Separately
 See section BC

B12	—	2	—	12T
12 size		2-Way Cavity		Port Size

Code	Porting / Body Material
12T	SAE-12 / Steel (5000 PSI)

Code	Pressure Range
10	6.9 - 69 Bar (100 - 1000 PSI) Standard Setting: 34.5 Bar (500 PSI) @ 11.3 LPM (3 GPM)
30	20.7 - 207 Bar (300 - 3000 PSI) Standard Setting: 103.5 Bar (1500 PSI) @ 11.3 LPM (3 GPM)
50	34.5 - 345 Bar (500 - 5000 PSI) Standard Setting: 172.4 Bar (2500 PSI) @ 11.3 LPM (3 GPM)

Kit	Part Number
Knob	717784-15
Tamper Resistant Cap	717785
Nitrile Seal	SK12-2
Fluorocarbon Seal	SK12-2V

CV	Check Valves
SH	Shuttle Valves
LM	Load/Motor Controls
FC	Flow Controls
PC	Pressure Controls
LE	Logic Elements
DC	Directional Controls
SV	Solenoid Valves
PV	Proportional Valves
CE	Coils & Electronics
BC	Bodies & Cavities
TD	Technical Data

General Description

Pilot Operated Spool-Type Relief Valve. For additional information see Technical Tips on pages PC3-PC7.

Features

- Hardened, precision ground parts for durability
- Low profile adapter for minimal space requirements
- Fully guided poppet for more consistent reseal
- Internal screening protects pilot seat from debris
- Steel adapters are zinc plated

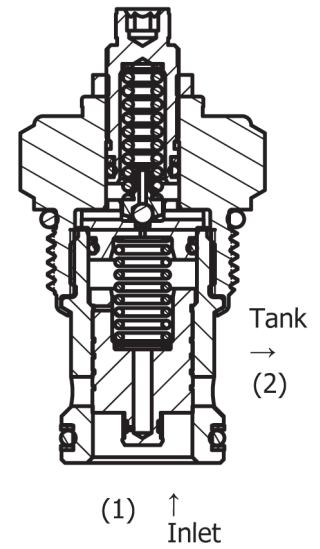
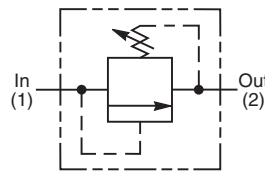
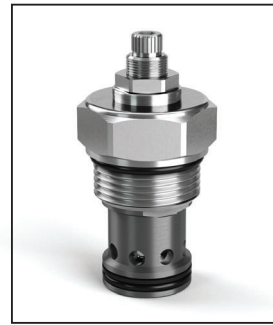

Specifications

Rated Flow	302.8 LPM (80 GPM)
Maximum Inlet Pressure	380 Bar (5500 PSI)
Maximum Pressure Setting	350 Bar (5000 PSI)
Sensitivity: Pressure/Turn	10 19.6 Bar (285 PSI) 20 39.3 Bar (570 PSI) 30 58.9 Bar (859 PSI) 50 131.7 Bar (1910 PSI)
Maximum Tank Pressure	350 Bar (5000 PSI)
Reseat Pressure	90% of crack pressure
Leakage at 150 SSU (32 cSt)	5 cc per 6.8 Bar (100 PSI) setting
Cartridge Material	All parts steel. All operating parts hardened steel.
Operating Temp. Range/Seals	-34°C to +121°C (Nitrile) (-30°F to +250°F) -26°C to +204°C (Fluorocarbon) (-15°F to +400°F)
Fluid Compatibility/Viscosity	Mineral-based or synthetic with lubricating properties at viscosities of 45 to 2000 SSU (6 to 420 cSt)
Filtration	ISO-4406 18/16/13, SAE Class 4
Approx. Weight	0.34 kg (0.75 lbs.)
Cavity	C16-2 (See BC Section for more details)

Performance Curve

Flow vs. Inlet Pressure
 (Pressure rise through cartridge only)

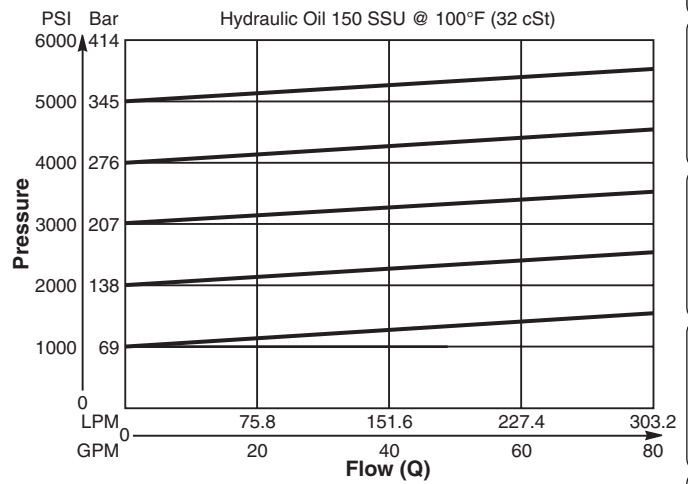

Performance Curve

Regulated Pressure vs. Flow
 (Pressure rise through cartridge only)

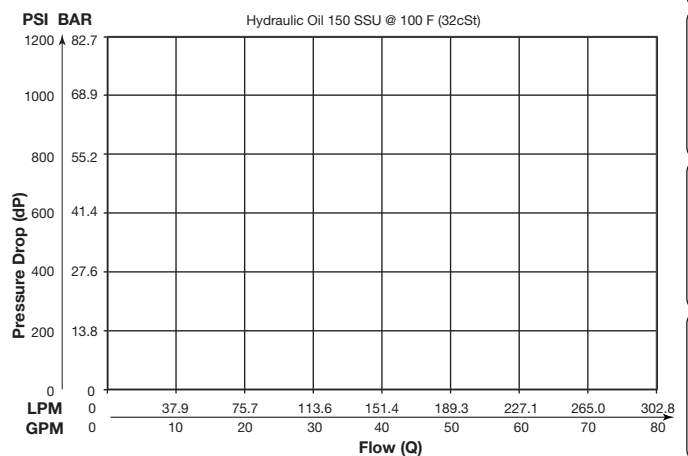

- CV
- Check Valves
- SH
- Shuttle Valves
- LM
- Load/Motor Controls
- FC
- Flow Controls
- PC
- Pressure Controls
- LE
- Logic Elements
- DC
- Directional Controls
- SV
- Solenoid Valves
- PV
- Proportional Valves
- CE
- Coils & Electronics
- BC
- Bodies & Cavities
- TD
- Technical Data

Dimensions Millimeters (Inches)

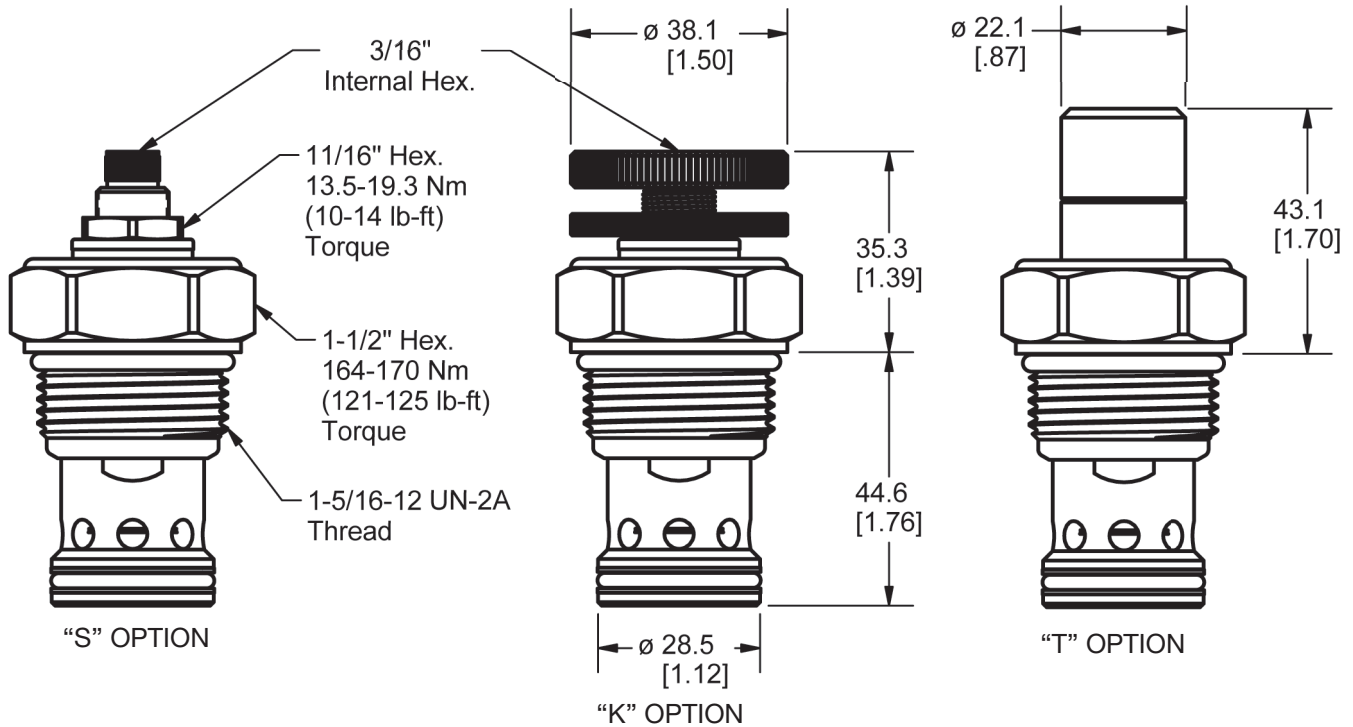

Ordering Information

RAH161	S	
16 Size Pilot Operated Relief Valve	Adjustment Style	Pressure Range

Highlighted represents preferred options that offer the shortest lead times. Other options may be available, but at extended lead times.

Code	Adjustment Style
S	Screw Adjust

Code	Seals
Omit	Nitrile

Order Bodies Separately
 See section BC

B16	—	2	—	16T
16 size		2-Way Cavity		Port Size

Code	Porting / Body Material
16T	SAE-16 / Steel (5000 PSI)

Code	Pressure Range
10	6.9 - 69 Bar (100 - 1000 PSI) Standard Setting: 34.5 Bar (500 PSI) @ .95 LPM (25 GPM)
30	20.7 - 207 Bar (300 - 3000 PSI) Standard Setting: 103.5 Bar (1500 PSI) @ .95 LPM (25 GPM)
50	34.5 - 345 Bar (500 - 5000 PSI) Standard Setting: 172.4 Bar (2500 PSI) @ .95 LPM (25 GPM)

Kit	Part Number
Knob	717784-15
Tamper Resistant Cap	717785
Nitrile Seal	SK16-2
Fluorocarbon Seal	SK16-2V

CV	Check Valves
SH	Shuttle Valves
LM	Load/Motor Controls
FC	Flow Controls
PC	Pressure Controls
LE	Logic Elements
DC	Directional Controls
SV	Solenoid Valves
PV	Proportional Valves
CE	Coils & Electronics
BC	Bodies & Cavities
TD	Technical Data

General Description

Pilot Operated Spool-Type Relief Valve.
 For additional information see Technical Tips on pages PC3-PC7.

Features

- Low override curve
- Ball-type pilot for added stability
- High accuracy - pilot operated design
- Hardened, precision ground parts for durability
- Compact size for reduced space requirements
- All external parts zinc plated

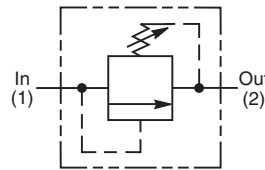
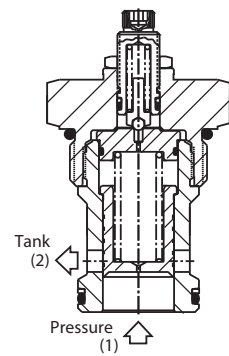

Specifications

Rated Flow	379 LPM (100 GPM)
Maximum Inlet Pressure	380 Bar (5500 PSI)
Maximum Pressure Setting	350 Bar (5000 PSI)
Sensitivity: Pressure/Turn	10 23 Bar (334 PSI) 30 59.7 Bar (867 PSI) 50 118 Bar (1711 PSI)
Maximum Tank Pressure	350 Bar (5000 PSI)
Reseat Pressure	80% of crack pressure
Leakage at 150 SSU (32 cSt)	5 cc per 6.8 Bar (100 PSI) setting
Cartridge Material	All parts steel. All operating parts hardened steel.
Operating Temp. Range/Seals	-34°C to +121°C (Nitrile) (-30°F to +250°F) -26°C to +204°C (Fluorocarbon) (-15°F to +400°F)
Fluid Compatibility/Viscosity	Mineral-based or synthetic with lubricating properties at viscosities of 45 to 2000 SSU (6 to 420 cSt)
Filtration	ISO-4406 18/16/13, SAE Class 4
Approx. Weight	0.9 kg (2.0 lbs.)
Cavity	C20-2 (See BC Section for more details)

Performance Curve

Flow vs. Inlet Pressure
 (Pressure rise through cartridge only)

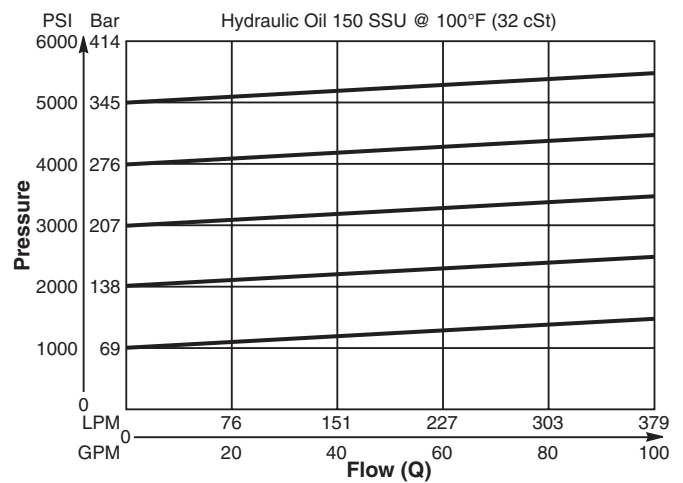

CV
Check Valves

SH
Shuttle Valves

LM
Load/Motor Controls

FC
Flow Controls

PC
Pressure Controls

LE
Logic Elements

DC
Directional Controls

SV
Solenoid Valves

PV
Proportional Valves

CE
Coils & Electronics

BC
Bodies & Cavities

TD
Technical Data

Dimensions Millimeters (Inches)

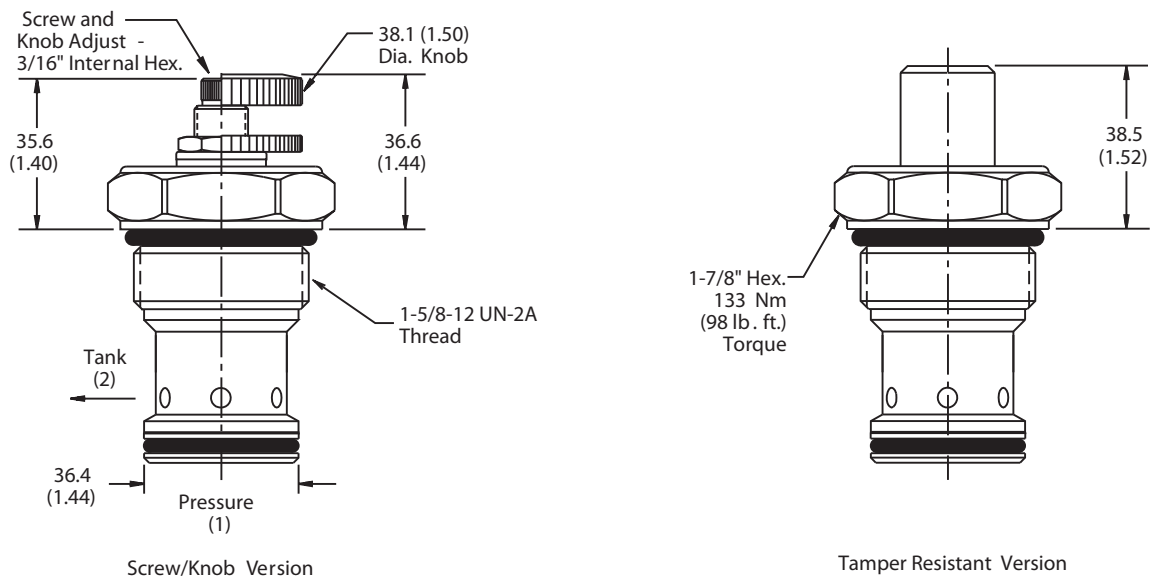

Ordering Information

RAH201	S	<input type="checkbox"/>
20 Size Pilot Operated Relief Valve	Adjustment Style	Pressure Range

Highlighted represents preferred options that offer the shortest lead times. Other options may be available, but at extended lead times.

Code	Adjustment Style
S	Screw Adjust

Code	Seals
Omit	Nitrile

Order Bodies Separately
 See section BC

B20	—	2	—	20T
20 size		2-Way Cavity		Port Size

Code	Porting / Body Material
20T	SAE-20 / Steel (5000 PSI)

Code	Pressure Range
10	6.9 - 69 Bar (100 - 1000 PSI) Standard Setting: 34.5 Bar (500 PSI) @ 37.5 LPM (10 GPM)
30	20.7 - 207 Bar (300 - 3000 PSI) Standard Setting: 103.5 Bar (1500 PSI) @ 37.5 LPM (10 GPM)
50	34.5 - 345 Bar (500 - 5000 PSI) Standard Setting: 172.4 Bar (2500 PSI) @ 37.5 LPM (10 GPM)

Kit	Part Number
Knob	717784-15
Tamper Resistant Cap	717785
Nitrile Seal	SK20-2
Fluorocarbon Seal	SK20-2V

CV
Check Valves
SH
Shuttle Valves
LM
Load/Motor Controls
FC
Flow Controls
PC
Pressure Controls
LE
Logic Elements
DC
Directional Controls
SV
Solenoid Valves
PV
Proportional Valves
CE
Coils & Electronics
BC
Bodies & Cavities
TD
Technical Data

General Description

Direct Acting, Dual Poppet-Type, Cross-over Relief Valve.

For additional information see Technical Tips on pages PC3-PC7.

Features

- Compact space saving design
- Cost effective - only requires one cavity
- Poppet-type construction for lower leakage
- Full 350 Bar, 5000 PSI pressure capability
- High flow capability for the size of valve
- Minimal pressure variation with flow change
- Hardened working parts for maximum durability
- All external parts zinc plated

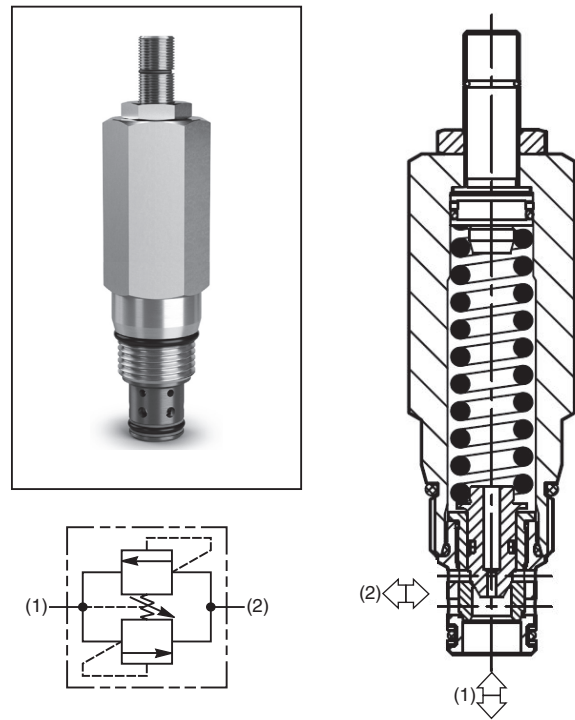

Specifications

Rated Flow	120 LPM (32 GPM)
Maximum Inlet Pressure	M- 10-350 Bar (144-5000 PSI)
Maximum Pressure Setting	350 Bar (5000 PSI)
Sensitivity: Pressure/Turn	M- 34 Bar (493 PSI)
Maximum Tank Pressure	350 Bar (5000 PSI)
Leakage at 150 SSU (32 cSt)	10 drops/min. @100 Bar (1450)
Cartridge Material	All parts steel. All operating parts hardened steel.
Operating Temp. Range/Seals	-34°C to +121°C (Nitrile) (-30°F to +250°F) -26°C to +204°C (Fluorocarbon) (-15°F to +400°F)
Fluid Compatibility/Viscosity	Mineral-based or synthetic with lubricating properties at viscosities of 45 to 2000 SSU (6 to 420 cSt)
Filtration	ISO-4406 18/16/13, SAE Class 4
Approx. Weight	0.29 kg (0.64 lbs.)
Cavity	C10-2 (See BC Section for more details)

Performance Curves

(Pressure rise through cartridge only)

Flow vs. Inlet Pressure 1 to 2 and 2 to 1

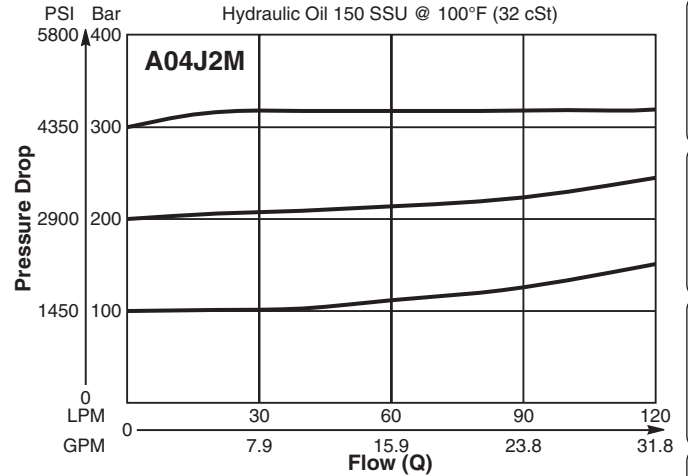

Application

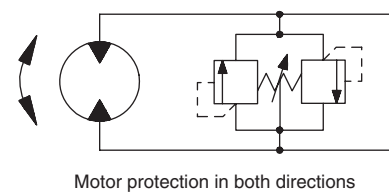

CV
Check Valves
SH
Shuttle Valves
LM
Load/Motor Controls
FC
Flow Controls
PC
Pressure Controls
LE
Logic Elements
DC
Directional Controls
SV
Solenoid Valves
PV
Proportional Valves
CE
Coils & Electronics
BC
Bodies & Cavities
TD
Technical Data

Dimensions Millimeters (Inches)

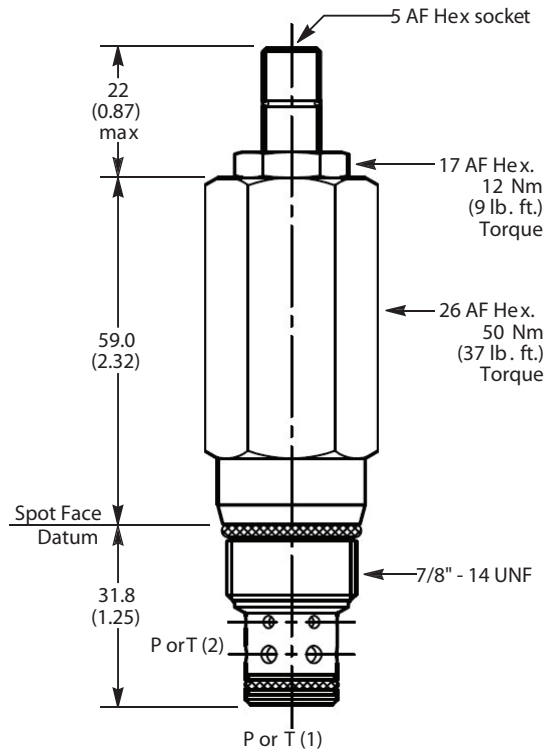

Ordering Information

A04J2	M	Z	N
10 Size Direct Acting Relief Valve	Pressure Adjustment Range	Adjustment Style	Seals

Highlighted represents preferred options that offer the shortest lead times. Other options may be available, but at extended lead times.

Code	Pressure Range
M	10 - 350 Bar (144 - 5000 PSI)

Standard Pressure Setting
A04J2M Standard Setting: 200 Bar (2900 PSI) @ 15 LPM (4.0 GPM)

Order Bodies Separately
 See section BC

B10	—	2	—	8T
10 size		2-Way Cavity		Port Size

Code	Adjustment Style
Z	Screw Adjust

Code	Porting / Body Material
8T	SAE-8 / Steel (5000 PSI)

Code	Seals
N	Nitrile

Kit	Part Number
Knob	ASV014975
Tamper Resistant Cap	TC1130
Nitrile Seal	SK30529N-1
Fluorocarbon Seal	SK30529V-1

CV	Check Valves
SH	Shuttle Valves
LM	Load/Motor Controls
FC	Flow Controls
PC	Pressure Controls
LE	Logic Elements
DC	Directional Controls
SV	Solenoid Valves
PV	Proportional Valves
CE	Coils & Electronics
BC	Bodies & Cavities
TD	Technical Data

General Description

Pressure Unloading Valve Assembly
 This valve is best suited for accumulator unloading circuits or can be used as a remote to pilot valves. They provide a fixed percentage between load and unload pressures.
 For additional information see Technical Tips on pages PC3-PC7.

Features

- Low hysteresis
- Cartridge design
- Hardened, precision ground parts for durability
- All external parts zinc plated
- “D”-Ring eliminates backup rings

Specifications

Rated Flow	1 LPM (.25 GPM)
Maximum Inlet Pressure	250 Bar (3600 PSI)
Maximum Pressure Setting	250 Bar (3600 PSI)
Pressure Sensitivity	12 = 112 PSI/Turn 24 = 214 PSI/Turn 36 = 367 PSI/Turn
Maximum Tank Pressure	210 Bar (3000 PSI)
Leakage at 150 SSU (32 cSt)	Port 1 leakage 48 ml/min. @207 Bar (3000 PSI)
Cartridge Material	All parts steel. All operating parts hardened steel.
Operating Temp. Range/Seals	-37°C to +93°C (“D”-Ring) (-35°F to +200°F) -34°C to +121°C (Nitrile) (-30°F to +250°F) -26°C to +204°C (Fluorocarbon) (-15°F to +400°F)
Fluid Compatibility/Viscosity	Mineral-based or synthetic with lubricating properties at viscosities of 45 to 2000 SSU (6 to 420 cSt)
Filtration	ISO-4406 18/16/13, SAE Class 4
Approx. Weight	0.45 kg (1.0 lbs.)
Cavity	C10-4 (See BC Section for more details)

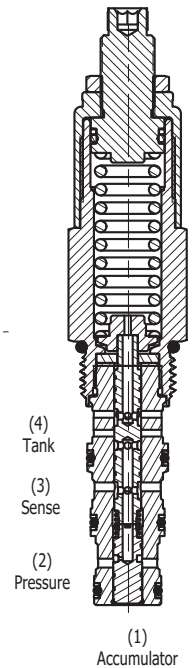
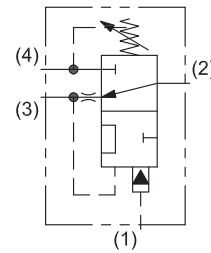
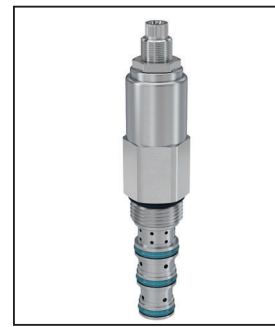

Typical Unloading Application

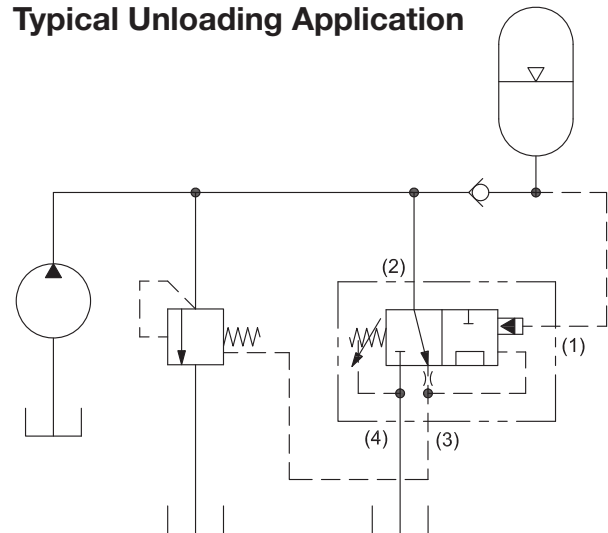

**Performance Curve
 Pump and Accumulator Pressure vs. Time**

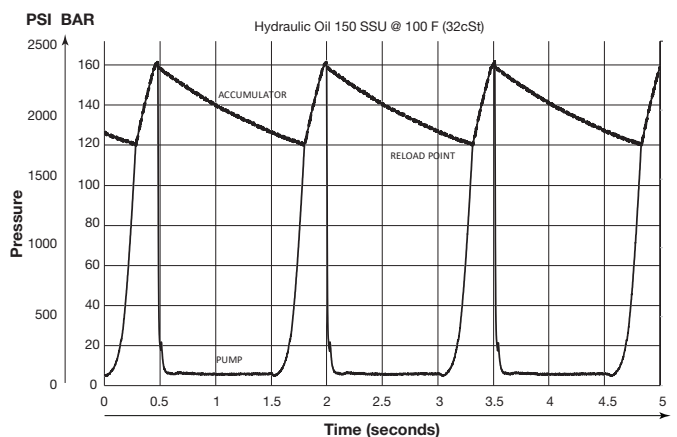

CV
Check Valves

SH
Shuttle Valves

LM
Load/Motor Controls

FC
Flow Controls

PC
Pressure Controls

LE
Logic Elements

DC
Directional Controls

SV
Solenoid Valves

PV
Proportional Valves

CE
Coils & Electronics

BC
Bodies & Cavities

TD
Technical Data

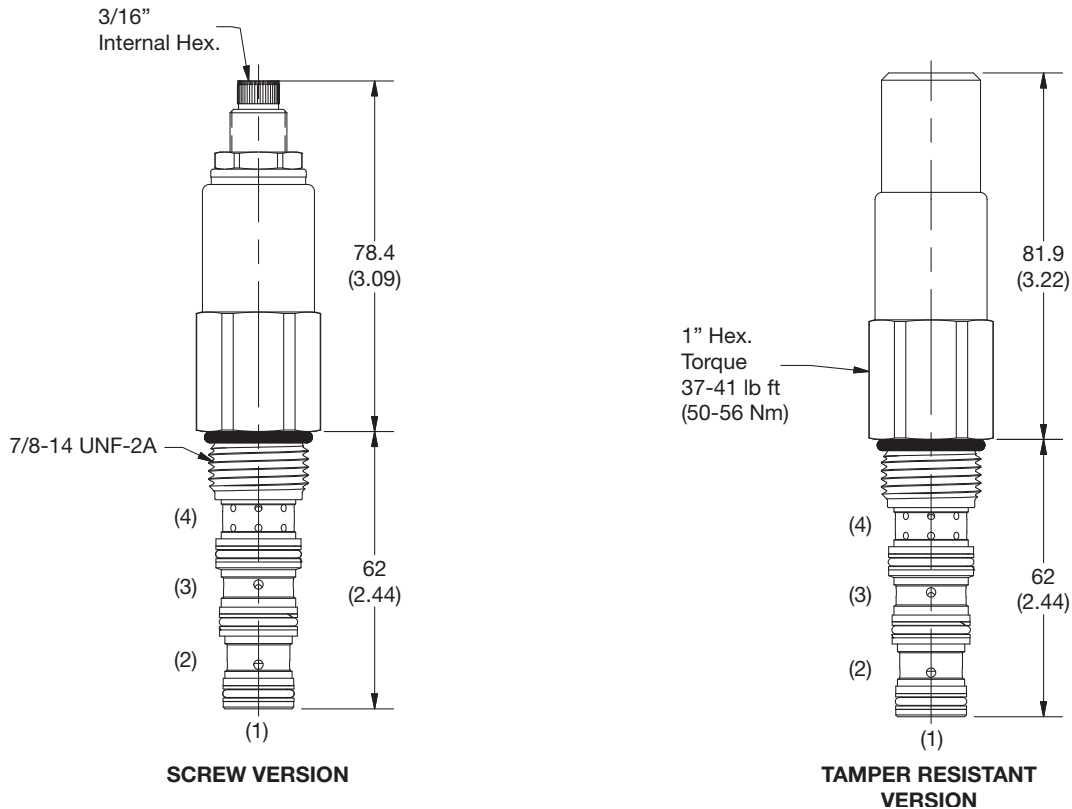

Ordering Information

RU104	S		B
10 Size Pressure Unloading Valve	Adjustment Style	Pressure Range	Reload

Highlighted represents preferred options that offer the shortest lead times. Other options may be available, but at extended lead times.

Code	Adjustment Style
S	Screw Adjust

Code	Reload
B	80% ±5% of Pressure Setting

Code	Pressure Range
12	55.2 - 82.7 Bar (800 - 1200 PSI) Standard Setting: 68.9 Bar (1000 PSI) @ 1.1 LPM (.3 GPM)
24	68.9 - 165.5 Bar (1000 - 2400 PSI) Standard Setting: 117.2 Bar (1700 PSI) @ 1.1 LPM (.3 GPM)
36	120.7 - 248.2 Bar (1750 - 3600 PSI) Standard Setting: 184.4 Bar (2675 PSI) @ 1.1 LPM (.3 GPM)

Code	Seals
Omit	D-Ring

Kit	Part Number
Tamper Resistant Cap	717943
D-Ring Seal	SK08-2
Nitrile Seal	SK08-2
Fluorocarbon Seal	SK08-2V

Order Bodies Separately
 See section BC

B10	—	4	—	8T
10 size		4-Way Cavity		Port Size

Code	Porting / Body Material
8T	SAE-8 / Steel (5000 PSI)

CV	Check Valves
SH	Shuttle Valves
LM	Load/Motor Controls
FC	Flow Controls
PC	Pressure Controls
LE	Logic Elements
DC	Directional Controls
SV	Solenoid Valves
PV	Proportional Valves
CE	Coils & Electronics
BC	Bodies & Cavities
TD	Technical Data

General Description

Pilot Operated Sequence Valve (Internally Piloted, Externally Vented).
 For additional information see Technical Tips on pages PC3-PC7.

Features

- Hardened, precision ground parts for durability
- Low profile adapter for minimal space requirements
- Fully guided pilot for more consistent reseal
- Steel adapters are zinc plated
- Polyurethane “D”-Ring eliminates backup rings and prevents hydrolysis
- Internal screening protects pilot spring from debris

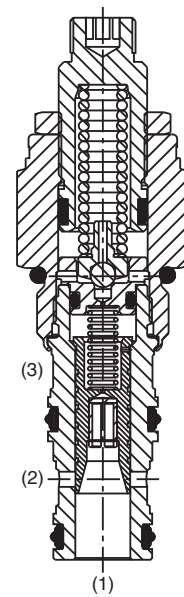
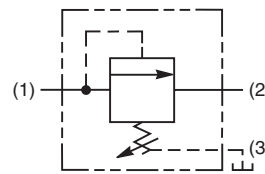

Specifications

Rated Flow	45 LPM (12 GPM)
Maximum Inlet Pressure	380 Bar (5500 PSI)
Maximum Pressure Setting	350 Bar (5000 PSI)
Sensitivity: Pressure/Turn	10 19.6 Bar (285 PSI) 30 58.9 Bar (859 PSI) 50 131.7 Bar (1910 PSI)
Maximum Tank Pressure	350 Bar (5000 PSI)
Maximum Drain Flow	0.56 LPM (0.15 GPM)
Reseat Pressure	90% of crack pressure
Leakage at 150 SSU (32 cSt)	82 cc/min. (5 cu. in./min.) @ 210 Bar (3000 PSI)
Cartridge Material	All parts steel. All operating parts hardened steel.
Operating Temp. Range/Seals	-37°C to +93°C (“D”-Ring) (-35°F to +200°F) -34°C to +121°C (Nitrile) (-30°F to +250°F) -26°C to +204°C (Fluorocarbon) (-15°F to +400°F)
Fluid Compatibility/Viscosity	Mineral-based or synthetic with lubricating properties at viscosities of 45 to 2000 SSU (6 to 420 cSt)
Filtration	ISO-4406 18/16/13, SAE Class 4
Approx. Weight	0.11 kg (0.25 lbs.)
Cavity	C08-3 (See BC Section for more details)

Performance Curves

Flow vs. Inlet Pressure

(Pressure rise through cartridge only)

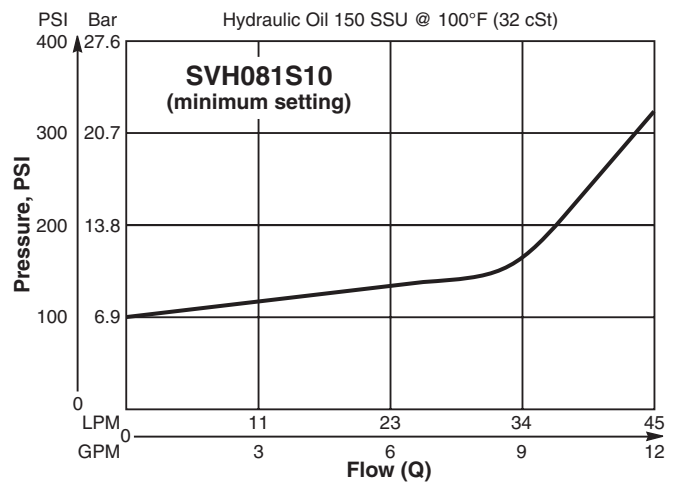
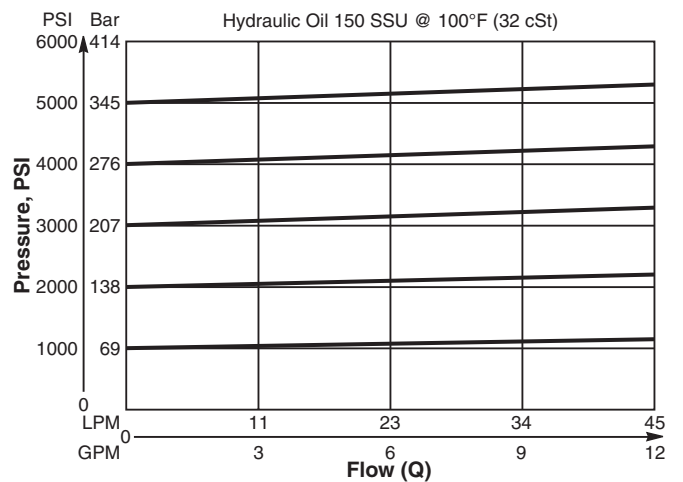

- CV Check Valves
- SH Shuttle Valves
- LM Load/Motor Controls
- FC Flow Controls
- PC Pressure Controls
- LE Logic Elements
- DC Directional Controls
- SV Solenoid Valves
- PV Proportional Valves
- CE Coils & Electronics
- BC Bodies & Cavities
- TD Technical Data

Dimensions Millimeters (Inches)

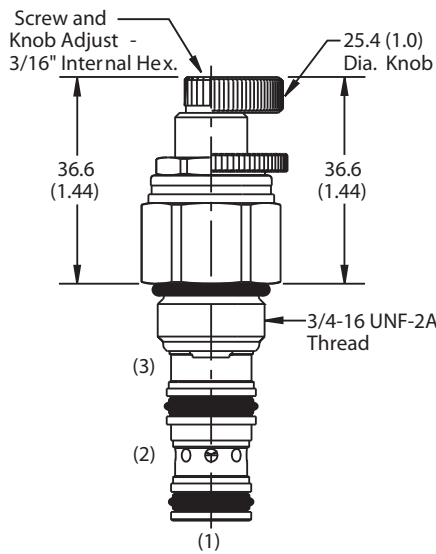

Screw/Knob Version

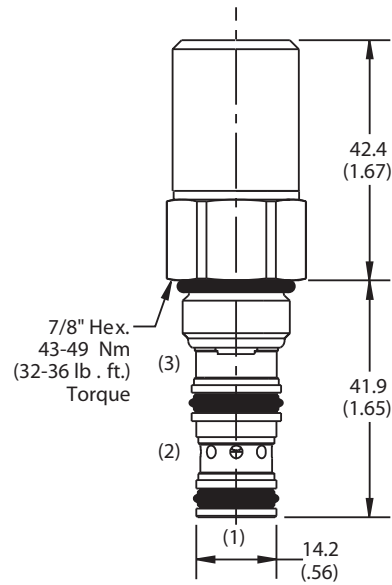

Tamper Resistant Version

Ordering Information

SVH081	S	<input type="checkbox"/>
08 Size P.O. Sequence Valve (Internal Pilot)	Adjustment Style	Pressure Range

Highlighted represents preferred options that offer the shortest lead times. Other options may be available, but at extended lead times.

Code	Adjustment Style
S	Screw Adjust

Code	Seals
Omit	D-Ring

Order Bodies Separately
 See section BC

B08	—	3	—	6T
08 size		3-Way Cavity		Port Size

Code	Porting / Body Material
6T	SAE-6 / Steel (5000 PSI)

Code	Pressure Range
10	6.9 - 69 Bar (100 - 1000 PSI) Standard Setting: 34.5 Bar (500 PSI) @ crack pressure, approximately .95 LPM (.25 GPM)
30	13.8 - 207 Bar (200 - 3000 PSI) Standard Setting: 103.5 Bar (1500 PSI) @ crack pressure, approximately .95 LPM (.25 GPM)
50	13.8 - 345 Bar (200 - 5000 PSI) Standard Setting: 172.4 Bar (2500 PSI) @ crack pressure, approximately .95 LPM (.25 GPM)

Kit	Part Number
Knob	717784-10
Tamper Resistant Cap	717943
D-Ring Seal	SK08-3
Nitrile Seal	SK08-3
Fluorocarbon Seal	SK08-3V

CV
Check Valves
SH
Shuttle Valves
LM
Load/Motor Controls
FC
Flow Controls
PC
Pressure Controls
LE
Logic Elements
DC
Directional Controls
SV
Solenoid Valves
PV
Proportional Valves
CE
Coils & Electronics
BC
Bodies & Cavities
TD
Technical Data

General Description

Pilot Operated Sequence Valve (Internally Piloted, Externally Drained).
 For additional information see Technical Tips on pages PC3-PC7.

Features

- Hardened, precision ground parts for durability
- Low profile adapter for minimal space requirements
- Fully guided poppet for more consistent reseal
- Steel adapters are zinc plated
- Polyurethane “D”-Ring eliminates backup rings and prevents hydrolysis
- Internal screening protects pilot spring from debris

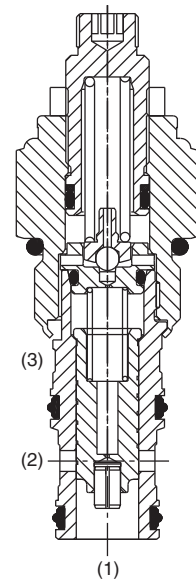
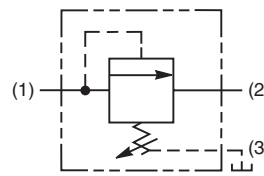

Specifications

Rated Flow	56.3 LPM (15 GPM)
Maximum Inlet Pressure	380 Bar (5500 PSI)
Maximum Pressure Setting	350 Bar (5000 PSI)
Sensitivity: Pressure/Turn	10 19.6 Bar (285 PSI) 30 58.9 Bar (859 PSI) 50 131.7 Bar (1910 PSI)
Maximum Tank Pressure	350 Bar (5000 PSI)
Maximum Drain Flow (Port 3)	0.94 LPM (0.25 GPM)
Reseat Pressure	90% of crack pressure
Leakage at 150 SSU (32 cSt)	82 cc/min. (5 cu. in./min.) @ 210 Bar (3000 PSI)
Cartridge Material	All parts steel. All operating parts hardened steel.
Operating Temp. Range/Seals	-37°C to +93°C (“D”-Ring) (-35°F to +200°F) -34°C to +121°C (Nitrile) (-30°F to +250°F) -26°C to +204°C (Fluorocarbon) (-15°F to +400°F)
Fluid Compatibility/Viscosity	Mineral-based or synthetic with lubricating properties at viscosities of 45 to 2000 SSU (6 to 420 cSt)
Filtration	ISO-4406 18/16/13, SAE Class 4
Approx. Weight	0.45 kg (1.0 lbs.)
Cavity	C10-3 (See BC Section for more details)

Performance Curves

Flow vs. Inlet Pressure

(Pressure rise through cartridge only)

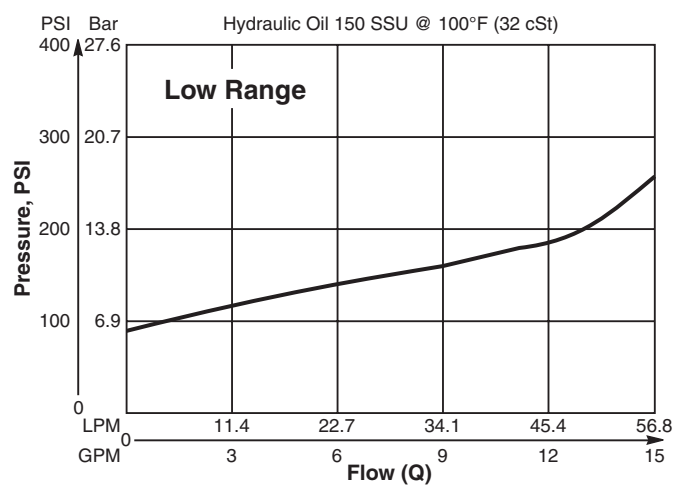
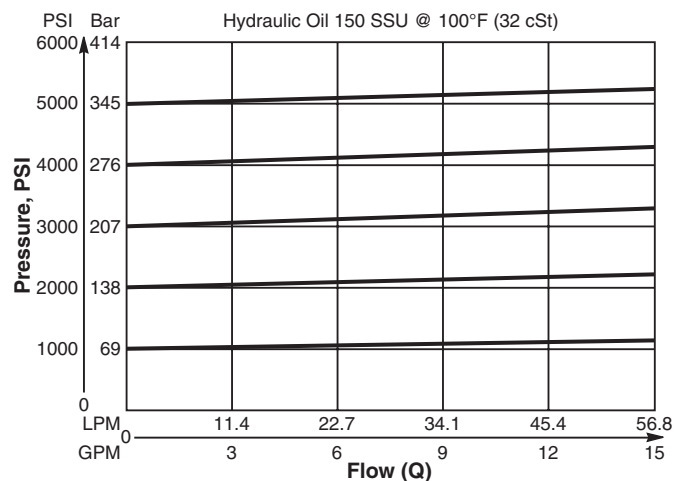

CV
Check Valves

SH
Shuttle Valves

LM
Load/Motor Controls

FC
Flow Controls

PC
Pressure Controls

LE
Logic Elements

DC
Directional Controls

SV
Solenoid Valves

PV
Proportional Valves

CE
Coils & Electronics

BC
Bodies & Cavities

TD
Technical Data

Dimensions Millimeters (Inches)

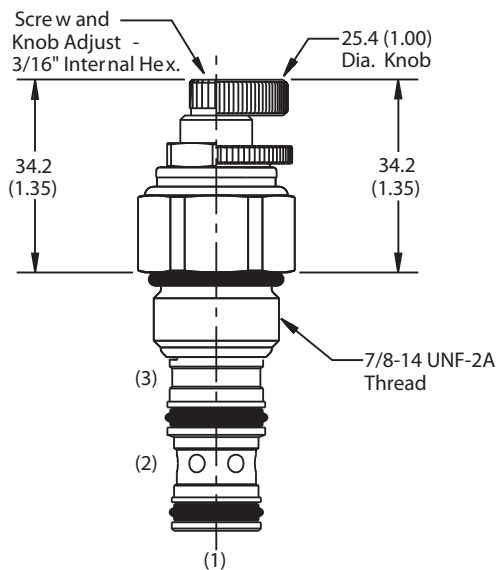

Screw/Knob Version

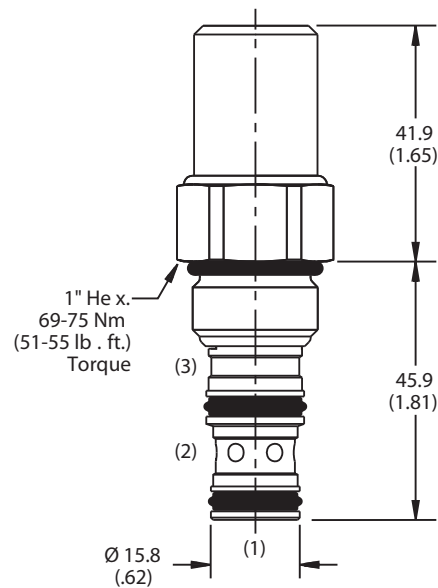

Tamper Resistant Version

Ordering Information

SVH101	S	<input type="checkbox"/>
10 Size P.O. Sequence Valve (Internal Pilot)	Adjustment Style	Pressure Range

Highlighted represents preferred options that offer the shortest lead times. Other options may be available, but at extended lead times.

Code	Adjustment Style
S	Screw Adjust

Code	Seals
Omit	D-Ring

Order Bodies Separately
 See section BC

B10	—	3	—	8T
10 size		3-Way Cavity		Port Size

Code	Porting / Body Material
8T	SAE-8 / Steel (5000 PSI)

Code	Pressure Range
10	6.9 - 69 Bar (100 - 1000 PSI) Standard Setting: 34.5 Bar (500 PSI) @ crack pressure, approximately .95 LPM (.25 GPM)
30	13.8 - 207 Bar (200 - 3000 PSI) Standard Setting: 103.5 Bar (1500 PSI) @ crack pressure, approximately .95 LPM (.25 GPM)
50	13.8 - 345 Bar (200 - 5000 PSI) Standard Setting: 172.4 Bar (2500 PSI) @ crack pressure, approximately .95 LPM (.25 GPM)

Kit	Part Number
Knob	717784-10
Tamper Resistant Cap	718083
D-Ring Seal	SK10-3
Nitrile Seal	SK10-3
Fluorocarbon Seal	SK10-3V

CV
Check Valves
SH
Shuttle Valves
LM
Load/Motor Controls
FC
Flow Controls
PC
Pressure Controls
LE
Logic Elements
DC
Directional Controls
SV
Solenoid Valves
PV
Proportional Valves
CE
Coils & Electronics
BC
Bodies & Cavities
TD
Technical Data

General Description

Pilot Operated Sequence Valve (Internally Piloted, Externally Drained). For additional information see Technical Tips on pages PC3-PC7.

Features

- Hardened, precision ground parts for durability
- High accuracy, pilot operation design
- Ball-type pilot for added stability
- All external parts zinc plated

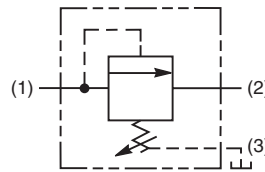
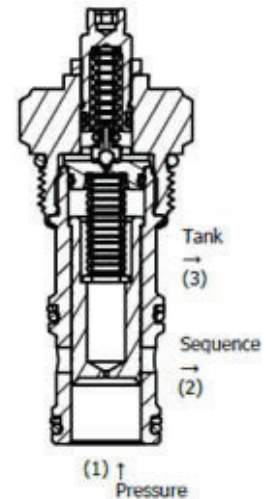
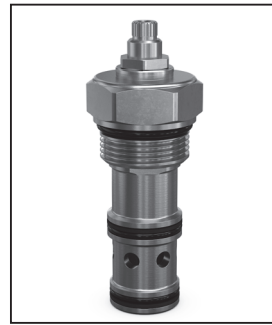

Specifications

Rated Flow	151.6 LPM (40 GPM)
Maximum Inlet Pressure	380 Bar (5500 PSI)
Maximum Pressure Setting	350 Bar (5000 PSI)
Sensitivity: Pressure/Turn	10 23 Bar (334 PSI) 30 59.7 Bar (867 PSI) 50 118 Bar (1711 PSI)
Maximum Tank Pressure	350 Bar (5000 PSI)
Maximum Drain Flow	1.9 LPM (0.5 GPM)
Reseat Pressure	80% of crack pressure
Leakage at 150 SSU (32 cSt)	5 cc per 6.8 Bar (100PSI) setting
Cartridge Material	All parts steel. All operating parts hardened steel.
Operating Temp. Range/Seals	-34°C to +121°C (Nitrile) (-30°F to +250°F) -26°C to +204°C (Fluorocarbon) (-15°F to +400°F)
Fluid Compatibility/Viscosity	Mineral-based or synthetic with lubricating properties at viscosities of 45 to 2000 SSU (6 to 420 cSt)
Filtration	ISO-4406 18/16/13, SAE Class 4
Approx. Weight	0.45 kg (1.0 lbs.)
Cavity	C16-3 (See BC Section for more details)

Performance Curve

Flow vs. Inlet Pressure
 (Pressure rise through cartridge only)

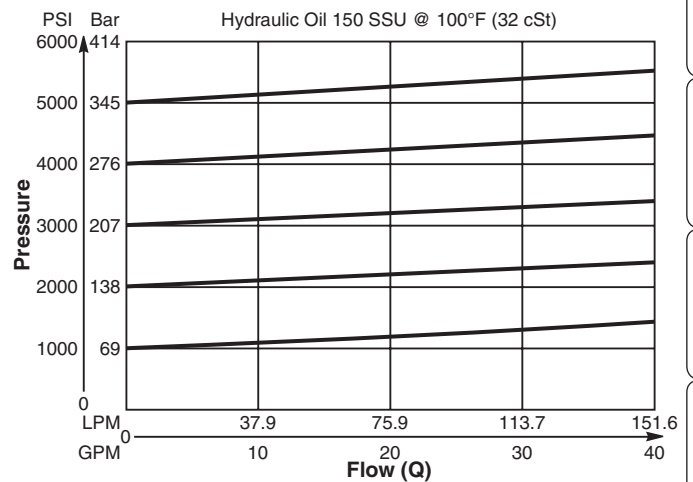

CV
Check Valves

SH
Shuttle Valves

LM
Load/Motor Controls

FC
Flow Controls

PC
Pressure Controls

LE
Logic Elements

DC
Directional Controls

SV
Solenoid Valves

PV
Proportional Valves

CE
Coils & Electronics

BC
Bodies & Cavities

TD
Technical Data

Dimensions Millimeters (Inches)

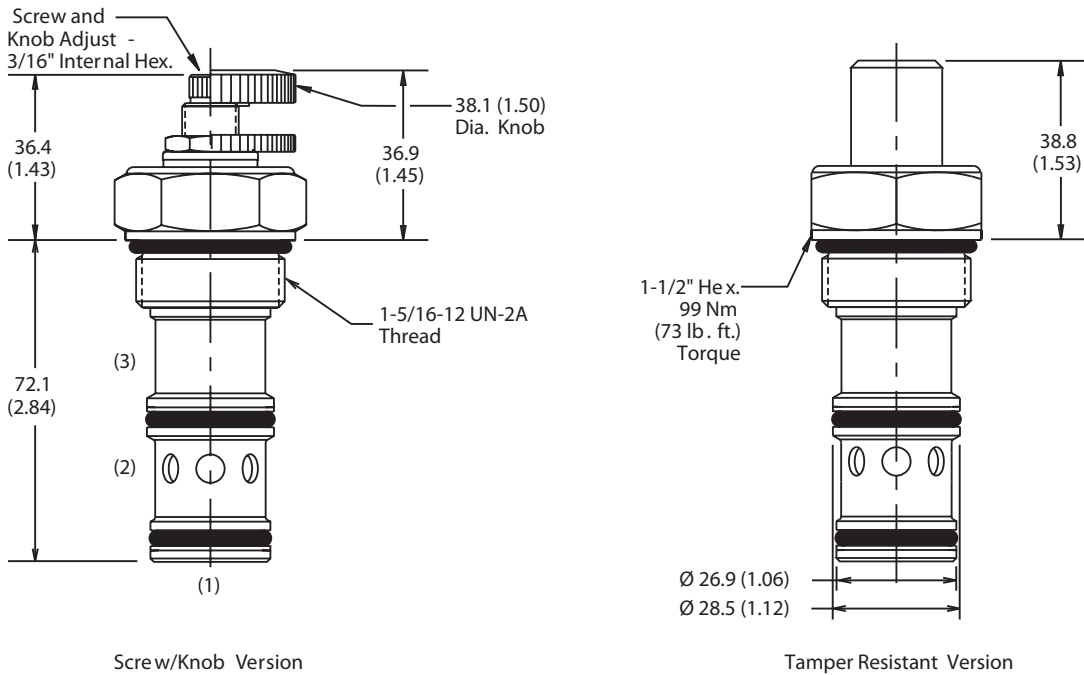

Screw/Knob Version

Tamper Resistant Version

Ordering Information

SVH161	S	
16 Size P.O. Sequence Valve (Internal Pilot)	Adjustment Style	Pressure Range

Highlighted represents preferred options that offer the shortest lead times. Other options may be available, but at extended lead times.

Code	Adjustment Style
S	Screw Adjust

Code	Seals
Omit	Nitrile

Order Bodies Separately
 See section BC

B16	—	3	—	16T
16 size		3-Way Cavity		Port Size

Code	Porting / Body Material
16T	SAE-16 / Steel (5000 PSI)

Code	Pressure Range
10	6.9 - 69 Bar (100 - 1000 PSI) Standard Setting: 34.5 Bar (500 PSI) @ 11.3 LPM (3 GPM)
30	20.7 - 207 Bar (300 - 3000 PSI) Standard Setting: 103.5 Bar (1500 PSI) @ 11.3 LPM (3 GPM)
50	34.5 - 345 Bar (500 - 5000 PSI) Standard Setting: 172.4 Bar (2500 PSI) @ 11.3 LPM (3 GPM)

Kit	Part Number
Knob	717784-15
Tamper Resistant Cap	717785
Nitrile Seal	SK16-3
Fluorocarbon Seal	SK16-3V

CV
Check Valves
SH
Shuttle Valves
LM
Load/Motor Controls
FC
Flow Controls
PC
Pressure Controls
LE
Logic Elements
DC
Directional Controls
SV
Solenoid Valves
PV
Proportional Valves
CE
Coils & Electronics
BC
Bodies & Cavities
TD
Technical Data

General Description

Pilot Operated Sequence Valve (Externally Piloted, Internally Vented).
 For additional information see Technical Tips on pages PC3-PC7.

Features

- Hardened, precision ground parts for durability
- Low profile adapter for minimal space requirements
- Fully guided poppet for more consistent reseal
- Steel adapters are zinc plated
- Polyurethane “D”-Ring eliminates backup rings and prevents hydrolysis
- Internal screening protects pilot spring from debris

Specifications

Rated Flow	56.3 LPM (15 GPM)
Maximum Inlet Pressure	380 Bar (5500 PSI)
Maximum Pressure Setting	350 Bar (5000 PSI)
Sensitivity: Pressure/Turn	10 19.6 Bar (285 PSI) 30 58.9 Bar (859 PSI) 50 131.7 Bar (1910 PSI)
Maximum Tank Pressure	350 Bar (5000 PSI)
Maximum Drain Flow	See maximum drain flow chart (Lower right)
Reseat Pressure	90% of crack pressure
Leakage at 150 SSU (32 cSt)	82 cc/min. (5 cu. in./min.) @ 210 Bar (3000 PSI)
Cartridge Material	All parts steel. All operating parts hardened steel.
Operating Temp. Range/Seals	-37°C to +93°C (“D”-Ring) (-35°F to +200°F) -34°C to +121°C (Nitrile) (-30°F to +250°F) -26°C to +204°C (Fluorocarbon) (-15°F to +400°F)
Fluid Compatibility/Viscosity	Mineral-based or synthetic with lubricating properties at viscosities of 45 to 2000 SSU (6 to 420 cSt)
Filtration	ISO-4406 18/16/13, SAE Class 4
Approx. Weight	0.45 kg (1.0 lbs.)
Cavity	C10-3 (See BC Section for more details)

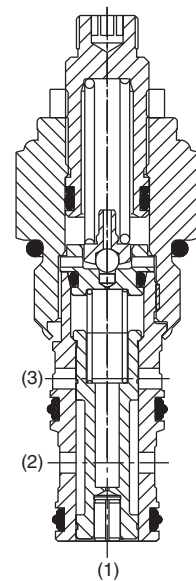
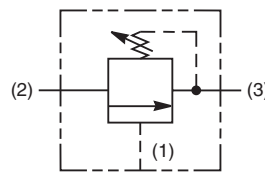

Performance Curve

Flow vs. Inlet Pressure

(Pressure rise through cartridge only)

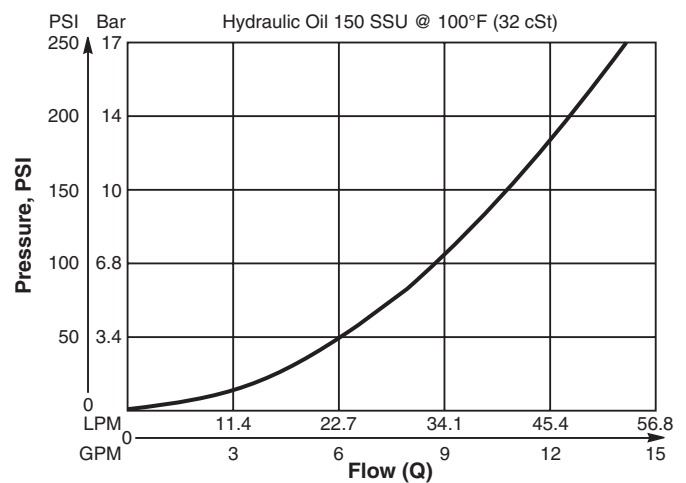

Maximum Drain Flow

$P_{PILOT} - P_{SETTING}$	Drain Flow
6.9 Bar (100 PSI)	0.34 LPM (0.09 GPM)
35 Bar (500 PSI)	0.76 LPM (0.20 GPM)
69 Bar (1000 PSI)	1.08 LPM (0.29 GPM)
138 Bar (2000 PSI)	1.53 LPM (0.40 GPM)
207 Bar (3000 PSI)	1.87 LPM (0.50 GPM)

CV
Check Valves

SH
Shuttle Valves

LM
Load/Motor Controls

FC
Flow Controls

PC
Pressure Controls

LE
Logic Elements

DC
Directional Controls

SV
Solenoid Valves

PV
Proportional Valves

CE
Coils & Electronics

BC
Bodies & Cavities

TD
Technical Data

Dimensions Millimeters (Inches)

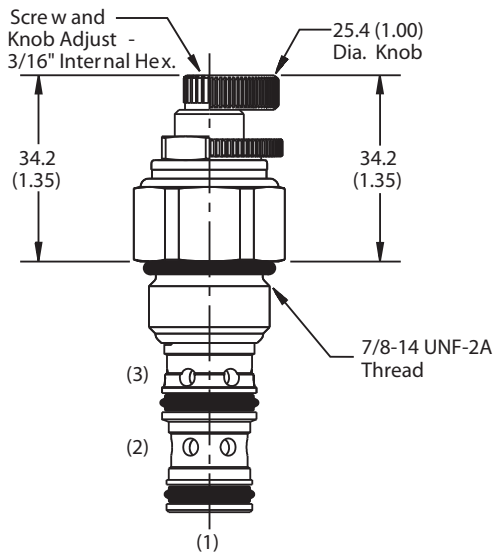

Screw/Knob Version

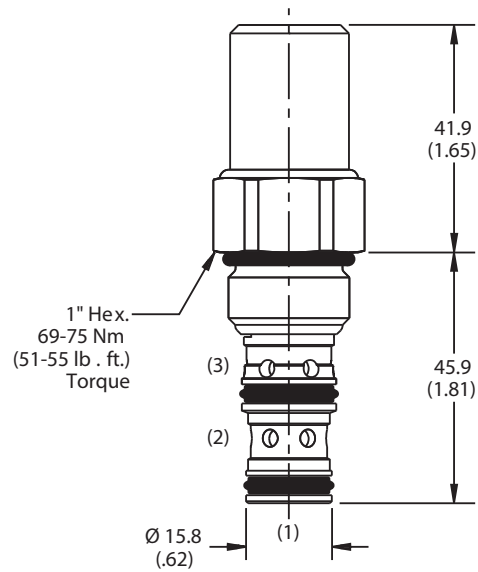

Tamper Resistant Version

Ordering Information

SVH102	S	<input type="checkbox"/>
10 Size P.O. Sequence Valve (External Pilot)	Adjustment Style	Pressure Range

Highlighted represents preferred options that offer the shortest lead times. Other options may be available, but at extended lead times.

Code	Adjustment Style
S	Screw Adjust

Code	Seals
Omit	D-Ring

Order Bodies Separately
 See section BC

B10	—	3	—	8T
10 size		3-Way Cavity		Port Size

Code	Porting / Body Material
8T	SAE-8 / Steel (5000 PSI)

Code	Pressure Range
10	20.7 - 69 Bar (100 - 1000 PSI) Standard Setting: 34.5 Bar (500 PSI) @ crack pressure, approximately 11.3 LPM (3 GPM)
30	13.8 - 207 Bar (200 - 3000 PSI) Standard Setting: 103.5 Bar (1500 PSI) @ crack pressure, approximately 11.3 LPM (3 GPM)
50	13.8 - 345 Bar (200 - 5000 PSI) Standard Setting: 172.4 Bar (2500 PSI) @ crack pressure, approximately 11.3 LPM (3 GPM)

Kit	Part Number
Knob	717784-10
Tamper Resistant Cap	718083
D-Ring Seal	SK10-3
Nitrile Seal	SK10-3
Fluorocarbon Seal	SK10-3V

CV	Check Valves
SH	Shuttle Valves
LM	Load/Motor Controls
FC	Flow Controls
PC	Pressure Controls
LE	Logic Elements
DC	Directional Controls
SV	Solenoid Valves
PV	Proportional Valves
CE	Coils & Electronics
BC	Bodies & Cavities
TD	Technical Data

General Description

Pilot Operated Sequence Valve (Externally Piloted, Internally Vented).
 For additional information see Technical Tips on pages PC3-PC7.

Features

- Hardened, precision ground parts for durability
- High accuracy, pilot operation design
- Ball-type pilot for added stability
- All external parts zinc plated

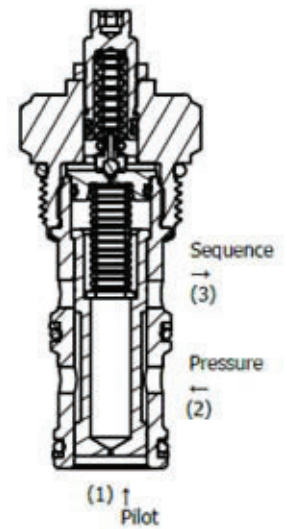
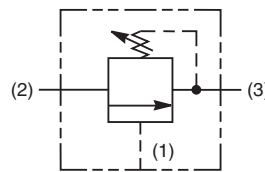

Specifications

Rated Flow	151.6 LPM (40 GPM)
Maximum Inlet Pressure	380 Bar (5500 PSI)
Maximum Pressure Setting	350 Bar (5000 PSI)
Sensitivity: Pressure/Turn	10 23 Bar (334 PSI) 30 59.7 Bar (867 PSI) 50 118 Bar (1711 PSI)
Maximum Tank Pressure	350 Bar (5000 PSI)
Maximum Drain Flow	See maximum drain flow chart (Lower right)
Reseat Pressure	80% of crack pressure
Leakage at 150 SSU (32 cSt)	82 cc/min. (5 cu. in./min.) @ 75% of Crack Pressure
Cartridge Material	All parts steel. All operating parts hardened steel.
Operating Temp. Range/Seals	-34°C to +121°C (Nitrile) (-30°F to +250°F) -26°C to +204°C (Fluorocarbon) (-15°F to +400°F)
Fluid Compatibility/Viscosity	Mineral-based or synthetic with lubricating properties at viscosities of 45 to 2000 SSU (6 to 420 cSt)
Filtration	ISO-4406 18/16/13, SAE Class 4
Approx. Weight	0.45 kg (1.0 lbs.)
Cavity	C16-3 (See BC Section for more details)

Performance Curve

Flow vs. Inlet Pressure
 (Pressure rise through cartridge only)

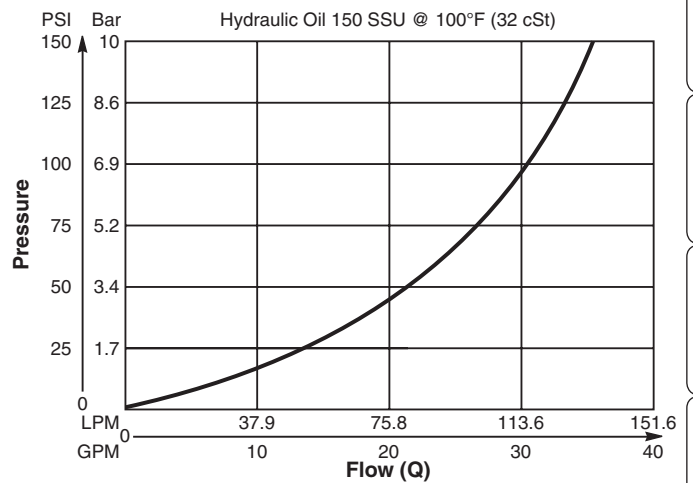

Maximum Drain Flow

$P_{PILOT} - P_{SETTING}$	Drain Flow
6.9 Bar (100 PSI)	0.69 LPM (0.18 GPM)
35 Bar (500 PSI)	1.55 LPM (0.41 GPM)
69 Bar (1000 PSI)	2.19 LPM (0.58 GPM)
138 Bar (2000 PSI)	3.10 LPM (0.82 GPM)
207 Bar (3000 PSI)	3.79 LPM (1.00 GPM)

- CV
- Check Valves
- SH
- Shuttle Valves
- LM
- Load/Motor Controls
- FC
- Flow Controls
- PC
- Pressure Controls
- LE
- Logic Elements
- DC
- Directional Controls
- SV
- Solenoid Valves
- PV
- Proportional Valves
- CE
- Coils & Electronics
- BC
- Bodies & Cavities
- TD
- Technical Data

Dimensions Millimeters (Inches)

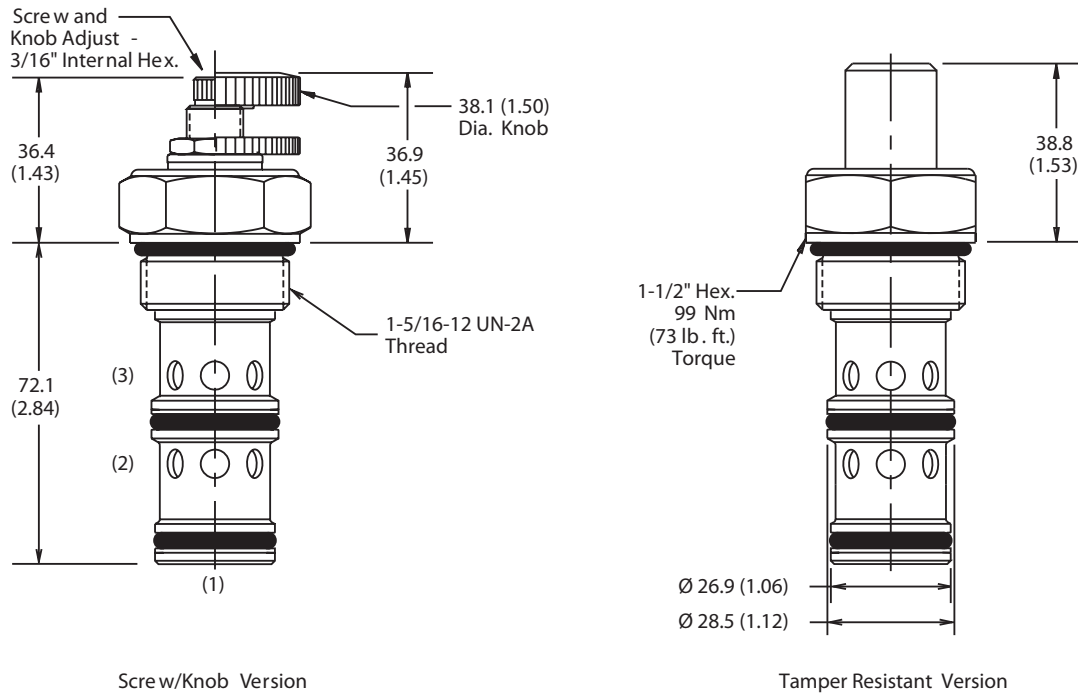

Screw/Knob Version

Tamper Resistant Version

Ordering Information

SVH162	S	<input type="checkbox"/>
16 Size P.O. Sequence Valve (External Pilot)	Adjustment Style	Pressure Range

Highlighted represents preferred options that offer the shortest lead times. Other options may be available, but at extended lead times.

Code	Adjustment Style
S	Screw Adjust

Code	Seals
Omit	Nitrile

Order Bodies Separately
 See section BC

B16	—	3	—	16T
16 size		3-Way Cavity		Port Size

Code	Porting / Body Material
16T	SAE-16 / Steel (5000 PSI)

Code	Pressure Range
10	6.9 - 69 Bar (100 - 1000 PSI) Standard Setting: 34.5 Bar (500 PSI) @ 11.3 LPM (3 GPM)
30	20.7 - 207 Bar (300 - 3000 PSI) Standard Setting: 103.5 Bar (1500 PSI) @ 11.3 LPM (3 GPM)
50	34.5 - 345 Bar (500 - 5000 PSI) Standard Setting: 172.4 Bar (2500 PSI) @ 11.3 LPM (3 GPM)

Kit	Part Number
Knob	717784-15
Tamper Resistant Cap	717785
Nitrile Seal	SK16-3
Fluorocarbon Seal	SK16-3V

CV	Check Valves
SH	Shuttle Valves
LM	Load/Motor Controls
FC	Flow Controls
PC	Pressure Controls
LE	Logic Elements
DC	Directional Controls
SV	Solenoid Valves
PV	Proportional Valves
CE	Coils & Electronics
BC	Bodies & Cavities
TD	Technical Data

General Description

Direct Acting Pressure Reducing/ Relieving Valve. For additional information see Technical Tips on pages PC3-PC7.

Note: The differential between system pressure and pressure setting of the valve can greatly affect the stability of this valve. For best performance, the inlet pressure setting should not exceed 69 Bar (1000 PSI) above the reducing valve setting.

Features

- Hardened, precision ground parts for durability
- Internal mechanical stop limits spool travel eliminating spring solidification
- “D”-Ring eliminates backup rings
- All external parts zinc plated

Specifications

Rated Flow	56 LPM (15 GPM)
Maximum Inlet Pressure	210 Bar (3000 PSI) 69 Bar (1000 PSI) maximum differential above valve setting for best stability
Maximum Pressure Setting	124 Bar (1800 PSI)
Sensitivity: Pressure/Turn	12 11.4 Bar (165 PSI) 21 17.2 Bar (250 PSI)
Maximum Tank Pressure	124 Bar (1800 PSI)
Maximum Drain Flow	120 ml/min. (0.03 GPM)
Cartridge Material	All parts steel. All operating parts hardened steel.
Operating Temp. Range/Seals	-37°C to +93°C (“D”-Ring) (-35°F to +200°F) -34°C to +121°C (Nitrile) (-30°F to +250°F) -26°C to +204°C (Fluorocarbon) (-15°F to +400°F)
Fluid Compatibility/ Viscosity	Mineral-based or synthetic with lubricating properties at viscosities of 45 to 2000 SSU (6 to 420 cSt)
Filtration	ISO-4406 18/16/13, SAE Class 4
Approx. Weight	0.23 kg (0.5 lbs.)
Cavity	C10-3 (See BC Section for more details)

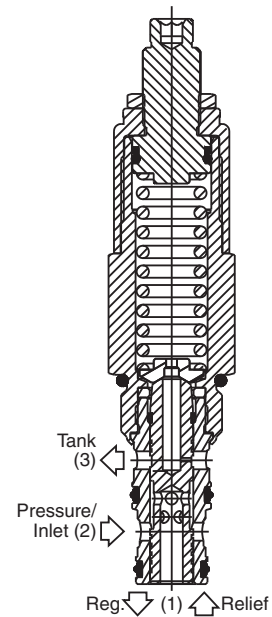
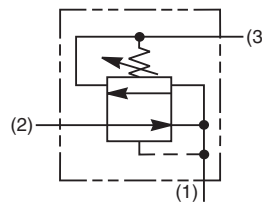

Performance Curves

(Pressure rise through cartridge only)

Flow vs. Regulated Pressure

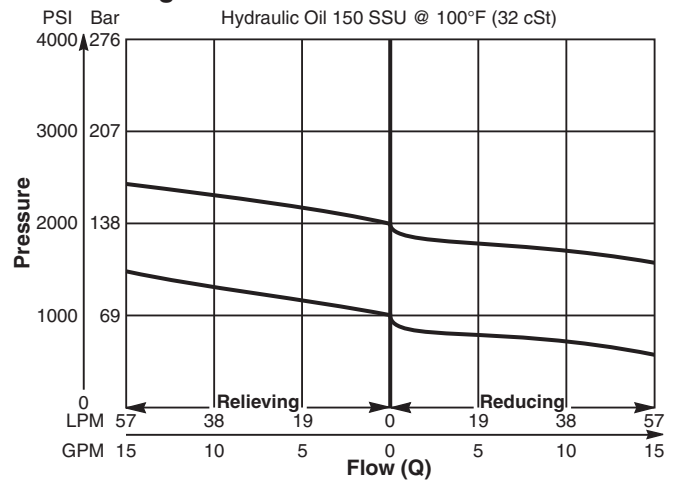

Pressure vs. Flow

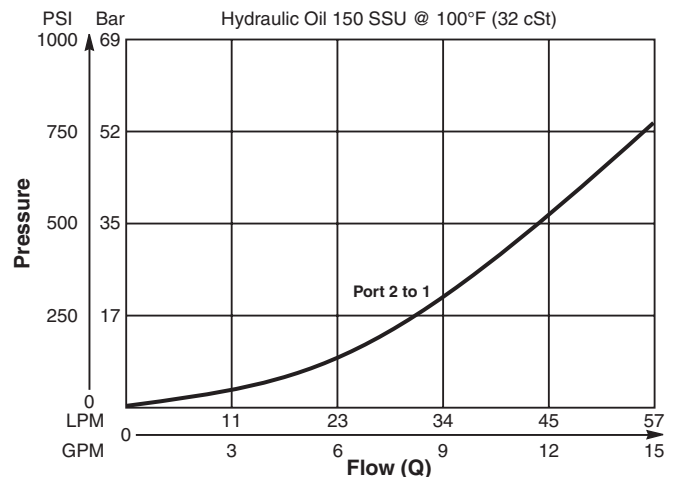

CV

Check Valves

SH

Shuttle Valves

LM

Load/Motor Controls

FC

Flow Controls

PC

Pressure Controls

LE

Logic Elements

DC

Directional Controls

SV

Solenoid Valves

PV

Proportional Valves

CE

Coils & Electronics

BC

Bodies & Cavities

TD

Technical Data

Dimensions Millimeters (Inches)

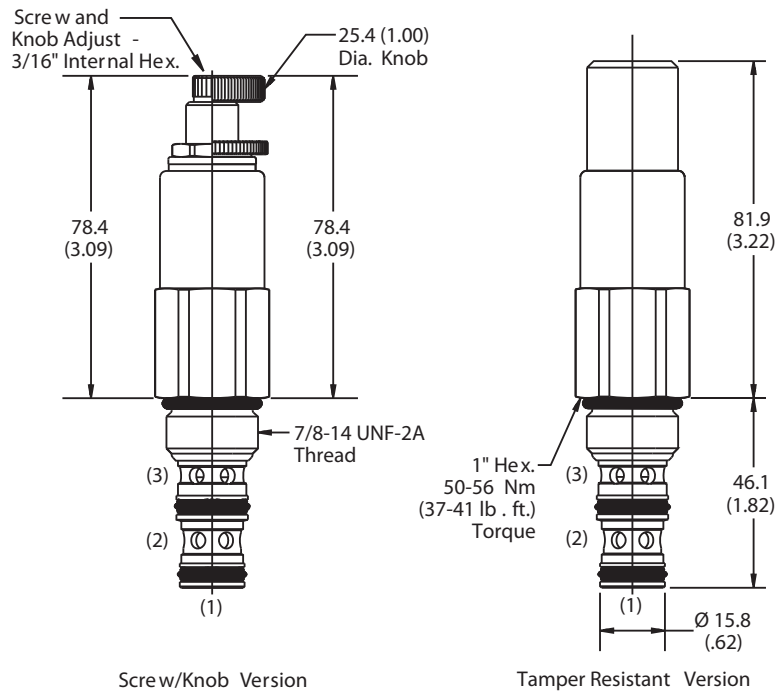

Ordering Information

PR103	S	<input type="checkbox"/>
10 Size D.A. Pressure Reducing/Relieving Valve	Adjustment Style	Pressure Range

Highlighted represents preferred options that offer the shortest lead times. Other options may be available, but at extended lead times.

Code	Adjustment Style
S	Screw Adjust

Code	Seals
Omit	D-Ring

Order Bodies Separately
 See section BC

B10	-	3	-	8T
10 size		3-Way Cavity		Port Size

Code	Porting / Body Material
8T	SAE-8 / Steel (5000 PSI)

Code	Pressure Range
12	39.3 - 83 Bar (570 - 1200 PSI) Standard Setting: 41.4 Bar (600 PSI) @ .95 LPM (.25 GPM)
21	41.4 - 124.1 Bar (600 - 1800 PSI) Standard Setting: 69 Bar (1000 PSI) @ .95 LPM (.25 GPM)

Kit	Part Number
Knob	717784-10
Tamper Resistant Cap	717943
D-Ring Seal	SK10-3
Nitrile Seal	SK10-3
Fluorocarbon Seal	SK10-3V

CV
Check Valves
SH
Shuttle Valves
LM
Load/Motor Controls
FC
Flow Controls
PC
Pressure Controls
LE
Logic Elements
DC
Directional Controls
SV
Solenoid Valves
PV
Proportional Valves
CE
Coils & Electronics
BC
Bodies & Cavities
TD
Technical Data

General Description

Pilot Operated Pressure Reducing Valve.
 For additional information see Technical Tips on pages PC3-PC7.

Features

- Hardened, precision ground parts for durability
- Low profile adapter for minimal space requirements
- Fully guided pilot for more consistent reseal
- Steel adapters are zinc plated
- Polyurethane “D”-Ring eliminates backup rings and prevents hydrolysis
- Internal screening protects pilot spring from debris

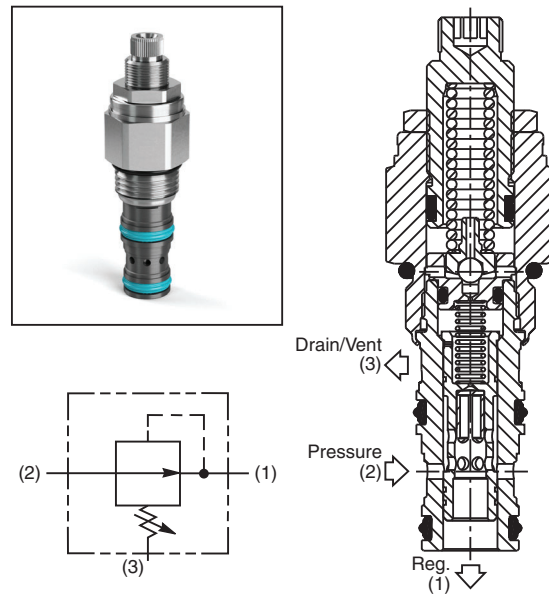

Specifications

Rated Flow	30 LPM (8 GPM)
Maximum Inlet Pressure	380 Bar (5500 PSI)
Maximum Pressure Setting	350 Bar (5000 PSI)
Sensitivity: Pressure/Turn	10 25 Bar (362 PSI) 30 64.2 Bar (932 PSI) 50 137 Bar (1987 PSI)
Maximum Tank Pressure	350 Bar (5000 PSI)
Maximum Drain Flow	0.56 LPM (0.15 GPM)
Cartridge Material	All parts steel. All operating parts hardened steel.
Operating Temp. Range/Seals	-37°C to +93°C (“D”-Ring) (-35°F to +200°F) -34°C to +121°C (Nitrile) (-30°F to +250°F) -26°C to +204°C (Fluorocarbon) (-15°F to +400°F)
Fluid Compatibility/Viscosity	Mineral-based or synthetic with lubricating properties at viscosities of 45 to 2000 SSU (6 to 420 cSt)
Filtration	ISO-4406 18/16/13, SAE Class 4
Approx. Weight	0.11 kg (0.25 lbs.)
Cavity	C08-3 (See BC Section for more details)

Performance Curves

Flow vs. Pressure (Through cartridge only)

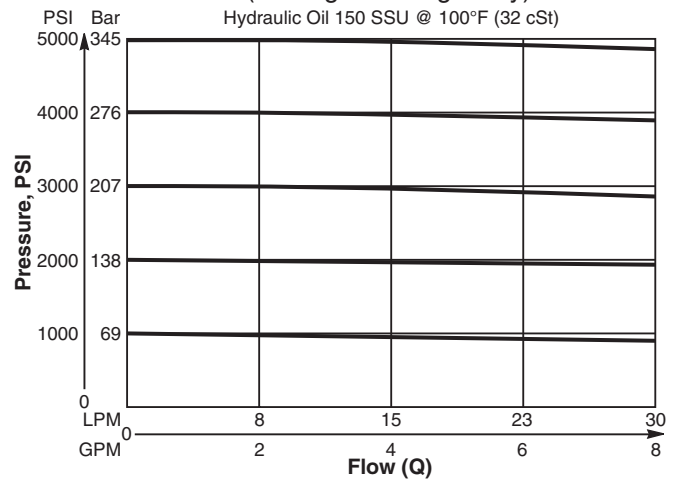

Flow vs. Pressure Drop (Through cartridge only)

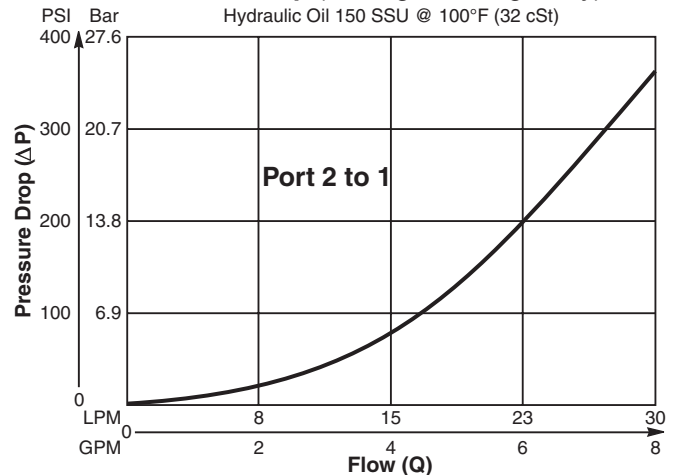

- CV
- Check Valves
- SH
- Shuttle Valves
- LM
- Load/Motor Controls
- FC
- Flow Controls
- PC
- Pressure Controls
- LE
- Logic Elements
- DC
- Directional Controls
- SV
- Solenoid Valves
- PV
- Proportional Valves
- CE
- Coils & Electronics
- BC
- Bodies & Cavities
- TD
- Technical Data

Dimensions Millimeters (Inches)

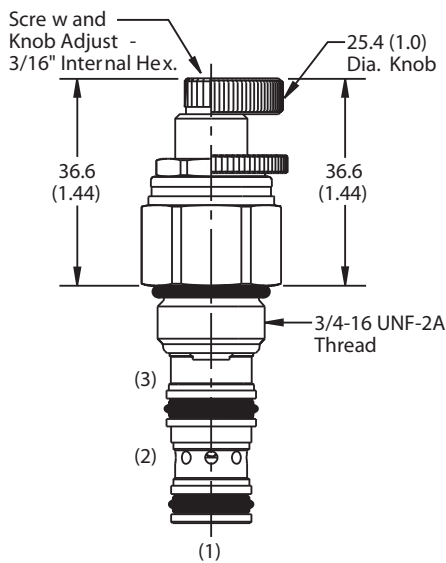

Screw/Knob Version

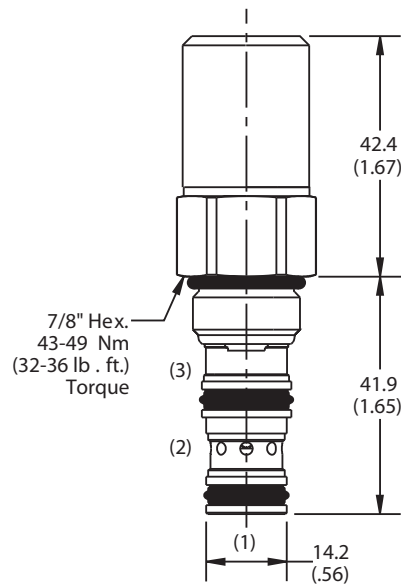

Tamper Resistant Version

Ordering Information

PRH082	S	<input type="checkbox"/>
08 Size P.O. Pressure Reducing Valve	Adjustment Style	Pressure Range

Highlighted represents preferred options that offer the shortest lead times. Other options may be available, but at extended lead times.

Code	Adjustment Style
S	Screw Adjust

Code	Seals
Omit	D-Ring

*Order Bodies Separately
See section BC*

B08	—	3	—	6T
08 size		3-Way Cavity		Port Size

Code	Porting / Body Material
6T	SAE-6 / Steel (5000 PSI)

Code	Pressure Range
10	6.9 - 69 Bar (100 - 1000 PSI) Standard Setting: 34.5 Bar (500 PSI)
30	13.8 - 207 Bar (200 - 3000 PSI) Standard Setting: 103.5 Bar (1500 PSI)
50	13.8 - 345 Bar (200 - 5000 PSI) Standard Setting: 172.4 Bar (2500 PSI)

NOTE: For settings below 20.7 Bar (300 PSI), flow rating is limited to 11.3 LPM (3 GPM).

Kit	Part Number
Knob	717784-10
Tamper Resistant Cap	717943
D-Ring Seal	SK08-3
Nitrile Seal	SK08-3
Fluorocarbon Seal	SK08-3V

CV
Check Valves
SH
Shuttle Valves
LM
Load/Motor Controls
FC
Flow Controls
PC
Pressure Controls
LE
Logic Elements
DC
Directional Controls
SV
Solenoid Valves
PV
Proportional Valves
CE
Coils & Electronics
BC
Bodies & Cavities
TD
Technical Data

General Description

Pilot Operated Pressure Reducing Valve.
 For additional information see Technical Tips on pages PC3-PC7.

Features

- Hardened, precision ground parts for durability
- Low profile adapter for minimal space requirements
- Fully guided poppet for more consistent reseal
- Steel adapters are zinc plated
- Polyurethane “D”-Ring eliminates backup rings and prevents hydrolysis
- Internal screening protects pilot spring from debris

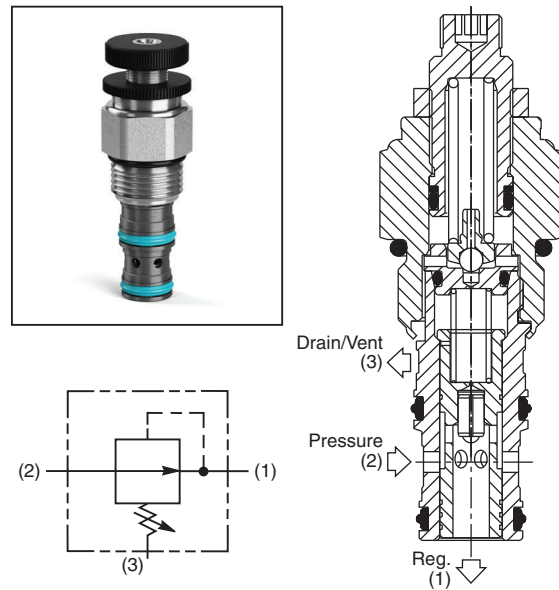

Specifications

Rated Flow	56.3 LPM (15 GPM)
Maximum Inlet Pressure	380 Bar (5500 PSI)
Maximum Pressure Setting	350 Bar (5000 PSI)
Sensitivity: Pressure/Turn	10 25.4 Bar (369 PSI) 30 64.9 Bar (942 PSI) 50 137.6 Bar (1996 PSI)
Maximum Tank Pressure	350 Bar (5000 PSI)
Maximum Drain Flow	0.94 LPM (0.25 GPM)
Cartridge Material	All parts steel. All operating parts hardened steel.
Operating Temp. Range/Seals	-37°C to +93°C (“D”-Ring) (-35°F to +200°F) -34°C to +121°C (Nitrile) (-30°F to +250°F) -26°C to +204°C (Fluorocarbon) (-15°F to +400°F)
Fluid Compatibility/Viscosity	Mineral-based or synthetic with lubricating properties at viscosities of 45 to 2000 SSU (6 to 420 cSt)
Filtration	ISO-4406 18/16/13, SAE Class 4
Approx. Weight	0.23 kg (0.5 lbs.)
Cavity	C10-3 (See BC Section for more details)

Performance Curves

Flow vs. Pressure (Through cartridge only)

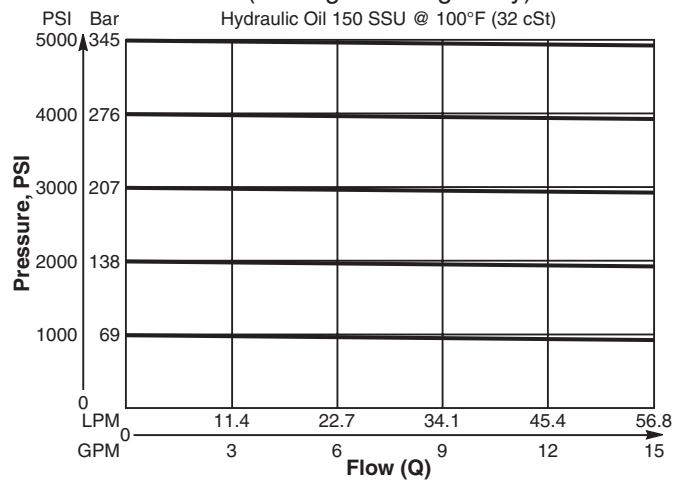

Pressure vs. Flow (Through cartridge only)

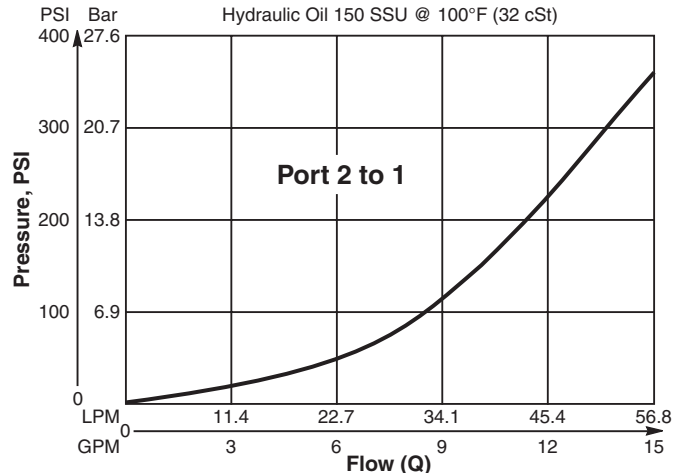

CV
Check Valves

SH
Shuttle Valves

LM
Load/Motor Controls

FC
Flow Controls

PC
Pressure Controls

LE
Logic Elements

DC
Directional Controls

SV
Solenoid Valves

PV
Proportional Valves

CE
Coils & Electronics

BC
Bodies & Cavities

TD
Technical Data

Dimensions Millimeters (Inches)

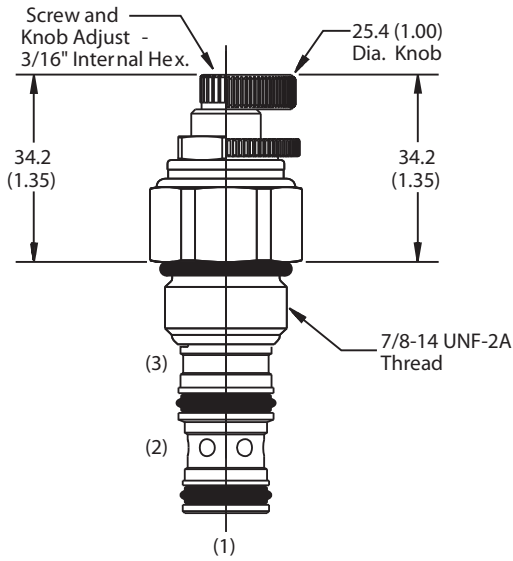

Screw/Knob Version

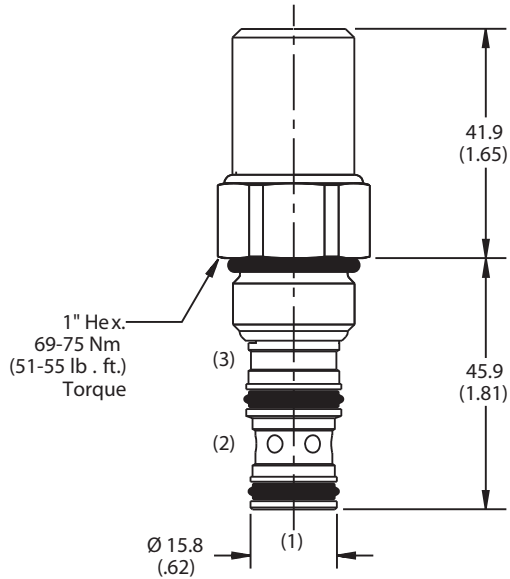

Tamper Resistant Version

Ordering Information

PRH102	S	□
10 Size P.O. Pressure Reducing Valve	Adjustment Style	Pressure Range

Highlighted represents preferred options that offer the shortest lead times. Other options may be available, but at extended lead times.

Code	Adjustment Style
S	Screw Adjust

Code	Seals
Omit	D-Ring

Order Bodies Separately
 See section BC

B10	—	3	—	8T
10 size		3-Way Cavity		Port Size

Code	Porting / Body Material
8T	SAE-8 / Steel (5000 PSI)

Code	Pressure Range
10	13.7 - 69 Bar (200 - 1000 PSI) Standard Setting: 34.5 Bar (500 PSI)
30	41.4 - 207 Bar (600 - 3000 PSI) Standard Setting: 103.5 Bar (1500 PSI)
50	82.8 - 345 Bar (1200 - 5000 PSI) Standard Setting: 172.4 Bar (2500 PSI)

NOTE: For settings below 20.7 Bar (300 PSI), flow rating is limited to 11.3 LPM (3 GPM).

Kit	Part Number
Knob	717784-10
Tamper Resistant Cap	717083
D-Ring Seal	SK10-3
Nitrile Seal	SK10-3
Fluorocarbon Seal	SK10-3V

CV	Check Valves
SH	Shuttle Valves
LM	Load/Motor Controls
FC	Flow Controls
PC	Pressure Controls
LE	Logic Elements
DC	Directional Controls
SV	Solenoid Valves
PV	Proportional Valves
CE	Coils & Electronics
BC	Bodies & Cavities
TD	Technical Data

General Description

Pilot Operated Pressure Reducing/ Relieving Valve.
 For additional information see Technical Tips on pages PC3-PC7.

Features

- Hardened, precision ground parts for durability
- Low profile adapter for minimal space requirements
- Fully guided pilot for more consistent reseal
- Steel adapters are zinc plated
- Polyurethane “D”-Ring eliminates backup rings and prevents hydrolysis
- Internal screening protects pilot spring from debris

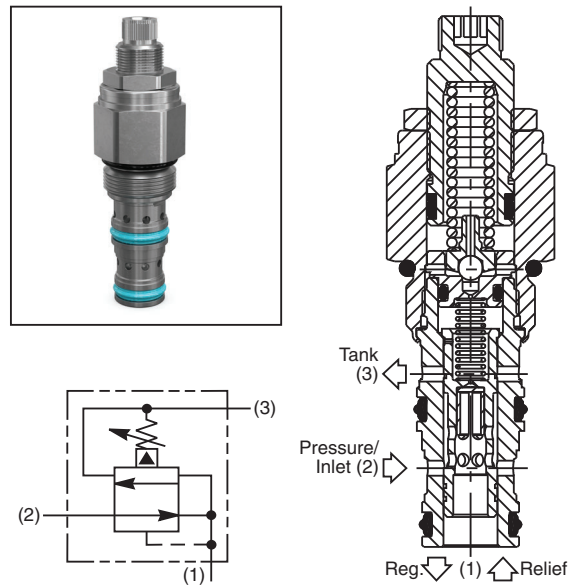

Specifications

Rated Flow	30 LPM (8 GPM)
Maximum Inlet Pressure	380 Bar (5500 PSI)
Maximum Pressure Setting	350 Bar (5000 PSI)
Sensitivity: Pressure/Turn	10 19.6 Bar (285 PSI) 30 58.9 Bar (859 PSI) 50 131.7 Bar (1910 PSI)
Maximum Tank Pressure	350 Bar (5000 PSI)
Maximum Drain Flow	0.56 LPM (0.15 GPM)
Cartridge Material	All parts steel. All operating parts hardened steel.
Operating Temp. Range/Seals	-37°C to +93°C (“D”-Ring) (-35°F to +200°F) -34°C to +121°C (Nitrile) (-30°F to +250°F) -26°C to +204°C (Fluorocarbon) (-15°F to +400°F)
Fluid Compatibility/Viscosity	Mineral-based or synthetic with lubricating properties at viscosities of 45 to 2000 SSU (6 to 420 cSt)
Filtration	ISO-4406 18/16/13, SAE Class 4
Approx. Weight	0.11 kg (0.25 lbs.)
Cavity	C08-3 (See BC Section for more details)

Performance Curves

Flow vs. Regulated Pressure (Through cartridge only)

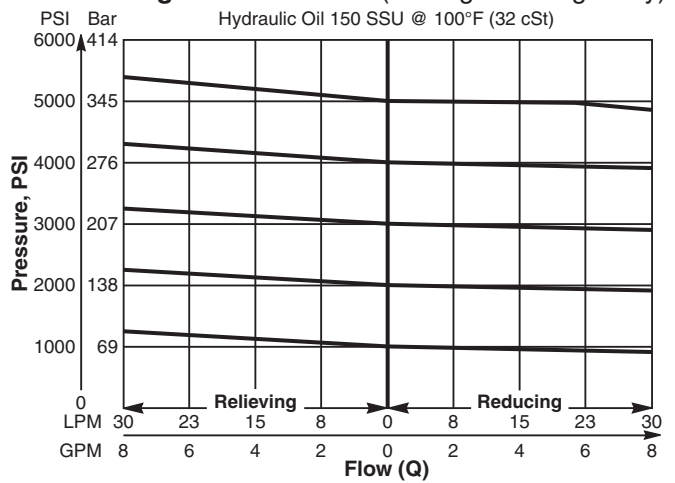

Flow vs. Pressure Drop (Through cartridge only)

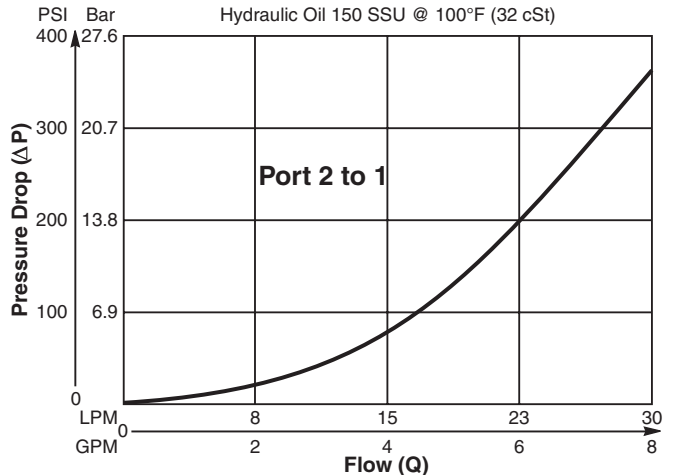

- CV
- Check Valves
- SH
- Shuttle Valves
- LM
- Load/Motor Controls
- FC
- Flow Controls
- PC
- Pressure Controls
- LE
- Logic Elements
- DC
- Directional Controls
- SV
- Solenoid Valves
- PV
- Proportional Valves
- CE
- Coils & Electronics
- BC
- Bodies & Cavities
- TD
- Technical Data

Dimensions Millimeters (Inches)

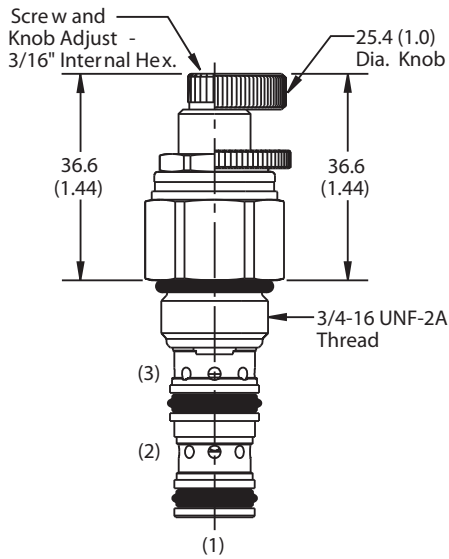

Screw/Knob Version

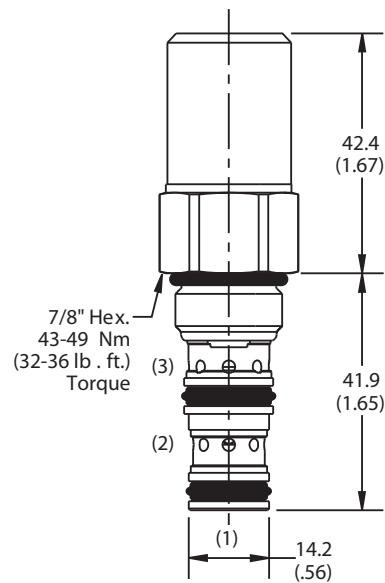

Tamper Resistant Version

Ordering Information

PRH081	S	<input type="checkbox"/>
08 Size P.O. Pressure Reducing/Relieving Valve	Adjustment Style	Pressure Range

Highlighted represents preferred options that offer the shortest lead times. Other options may be available, but at extended lead times.

Code	Adjustment Style
S	Screw Adjust

Code	Seals
Omit	D-Ring

Order Bodies Separately
 See section BC

B08	—	3	—	6T
08 size		3-Way Cavity		Port Size

Code	Porting / Body Material
6T	SAE-6 / Steel (5000 PSI)

Code	Pressure Range
10	6.9 - 69 Bar (100 - 1000 PSI) Standard Setting: 34.5 Bar (500 PSI)
30	13.8 - 207 Bar (200 - 3000 PSI) Standard Setting: 103.5 Bar (1500 PSI)
50	13.8 - 345 Bar (200 - 5000 PSI) Standard Setting: 172.4 Bar (2500 PSI)

NOTE: For settings below 20.7 Bar (300 PSI), flow rating is limited to 11.3 LPM (3 GPM).

Kit	Part Number
Knob	717784-10
Tamper Resistant Cap	717943
D-Ring Seal	SK08-3
Nitrile Seal	SK08-3
Fluorocarbon Seal	SK08-3V



CV	Check Valves
SH	Shuttle Valves
LM	Load/Motor Controls
FC	Flow Controls
PC	Pressure Controls
LE	Logic Elements
DC	Directional Controls
SV	Solenoid Valves
PV	Proportional Valves
CE	Coils & Electronics
BC	Bodies & Cavities
TD	Technical Data

General Description

Pilot Operated Pressure Reducing / Relieving Valve.
 For additional information see Technical Tips on pages PC3-PC7.

Features

- Hardened, precision ground parts for durability
- Low profile adapter for minimal space requirements
- Fully guided poppet for more consistent reseal
- Steel adapters are zinc plated
- Polyurethane “D”-Ring eliminates backup rings and prevents hydrolysis
- Internal screening protects pilot spring from debris

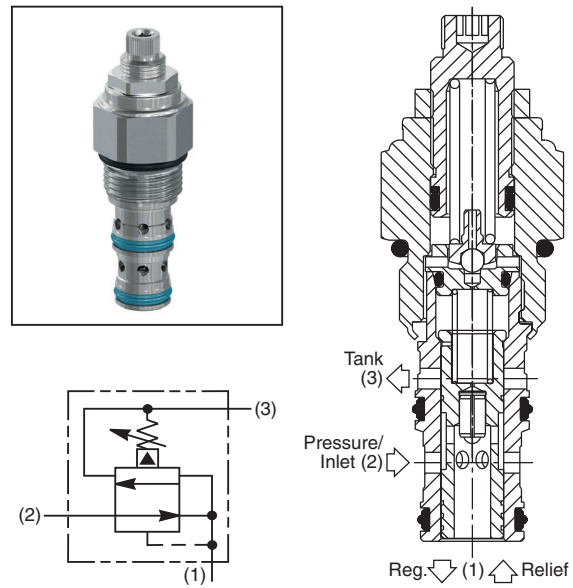

Specifications

Rated Flow	56.3 LPM (15 GPM)
Maximum Inlet Pressure	380 Bar (5500 PSI)
Maximum Pressure Setting	350 Bar (5000 PSI)
Sensitivity: Pressure/Turn	10 19.6 Bar (285 PSI) 30 58.9 Bar (859 PSI) 50 131.7 Bar (1910 PSI)
Maximum Tank Pressure	350 Bar (5000 PSI)
Maximum Drain Flow	0.94 LPM (0.25 GPM)
Cartridge Material	All parts steel. All operating parts hardened steel.
Operating Temp. Range/Seals	-37°C to +93°C (“D”-Ring) (-35°F to +200°F) -34°C to +121°C (Nitrile) (-30°F to +250°F) -26°C to +204°C (Fluorocarbon) (-15°F to +400°F)
Fluid Compatibility/Viscosity	Mineral-based or synthetic with lubricating properties at viscosities of 45 to 2000 SSU (6 to 420 cSt)
Filtration	ISO-4406 18/16/13, SAE Class 4
Approx. Weight	0.23 kg (0.5 lbs.)
Cavity	C10-3 (See BC Section for more details)

Performance Curves

Flow vs. Regulated Pressure (Through cartridge only)

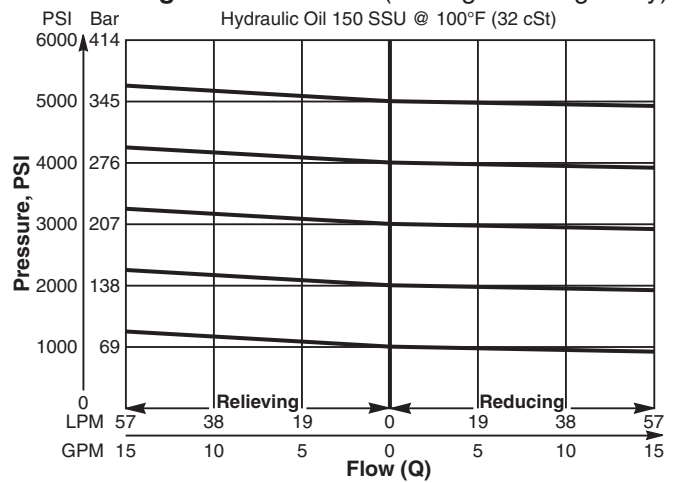

Pressure vs. Flow (Through cartridge only)

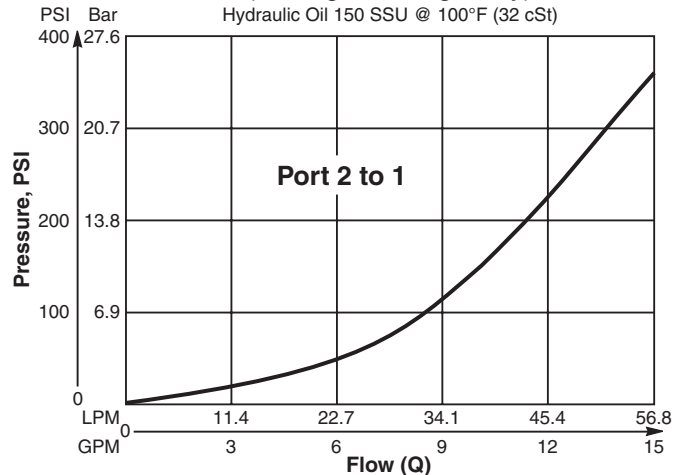

- CV
- Check Valves
- SH
- Shuttle Valves
- LM
- Load/Motor Controls
- FC
- Flow Controls
- PC
- Pressure Controls
- LE
- Logic Elements
- DC
- Directional Controls
- SV
- Solenoid Valves
- PV
- Proportional Valves
- CE
- Coils & Electronics
- BC
- Bodies & Cavities
- TD
- Technical Data

Dimensions Millimeters (Inches)

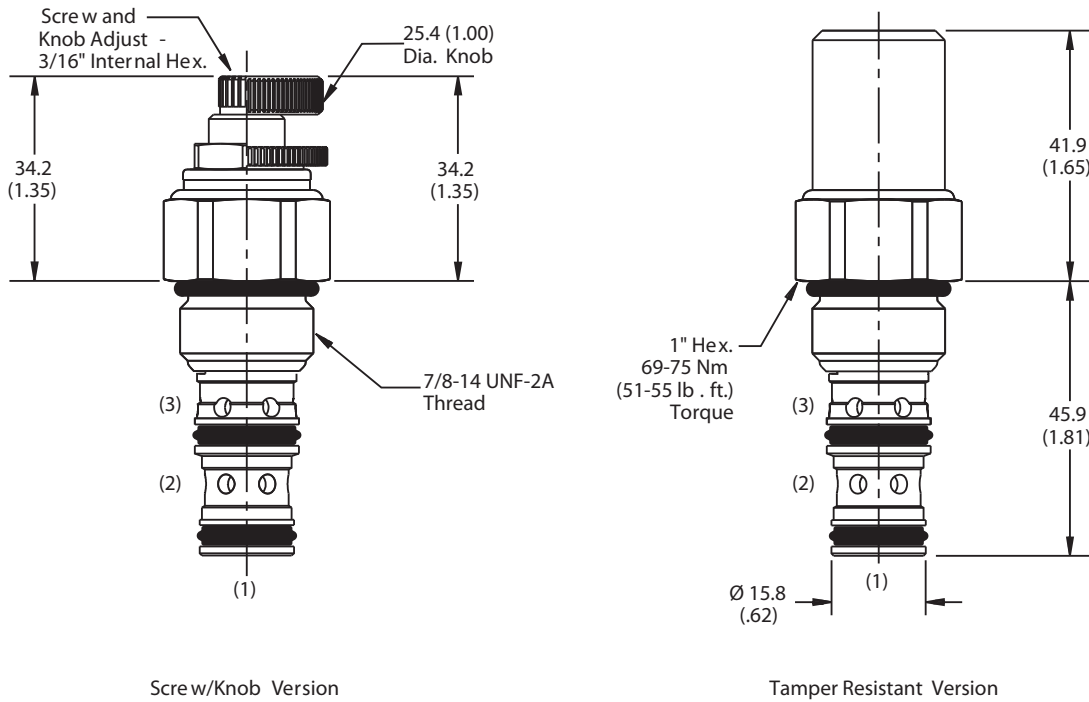

Screw/Knob Version

Tamper Resistant Version

Ordering Information

PRH101	S	<input type="checkbox"/>
10 Size P.O. Pressure Reducing / Relieving Valve	Adjustment Style	Pressure Range

Highlighted represents preferred options that offer the shortest lead times. Other options may be available, but at extended lead times.

Code	Adjustment Style
S	Screw Adjust

Code	Seals
Omit	D-Ring

Order Bodies Separately
 See section BC

B10	—	3	—	8T
10 size		3-Way Cavity		Port Size

Code	Porting / Body Material
8T	SAE-8 / Steel (5000 PSI)

Code	Pressure Range
10	13.7 - 69 Bar (200 - 1000 PSI) Standard Setting: 34.5 Bar (500 PSI)
30	41.4 - 207 Bar (600 - 3000 PSI) Standard Setting: 103.5 Bar (1500 PSI)
50	82.8 - 345 Bar (1200 - 5000 PSI) Standard Setting: 172.4 Bar (2500 PSI)

NOTE: For settings below 20.7 Bar (300 PSI), flow rating is limited to 11.3 LPM (3 GPM).

Kit	Part Number
Knob	717784-10
Tamper Resistant Cap	718083
D-Ring Seal	SK10-3
Nitrile Seal	SK10-3
Fluorocarbon Seal	SK10-3V

CV	Check Valves
SH	Shuttle Valves
LM	Load/Motor Controls
FC	Flow Controls
PC	Pressure Controls
LE	Logic Elements
DC	Directional Controls
SV	Solenoid Valves
PV	Proportional Valves
CE	Coils & Electronics
BC	Bodies & Cavities
TD	Technical Data

General Description

Pilot Operated Pressure Reducing/Relieving Valve.
 For additional information see Technical Tips on pages PC3-PC7.

Features

- Hardened, precision ground parts for durability
- Low profile adapter for minimal space requirements
- Fully guided poppet for more consistent reseal
- All external parts zinc plated

Specifications

Rated Flow	151.4 LPM (40 GPM)
Maximum Inlet Pressure	380 Bar (5500 PSI)
Maximum Pressure Setting	350 Bar (5000 PSI)
Sensitivity: Pressure/Turn	10 19.6 Bar (285 PSI) 30 58.9 Bar (859 PSI) 50 131.7 Bar (1910 PSI)
Maximum Tank Pressure	350 Bar (5000 PSI)
Reseat Pressure	90% of crack pressure
Leakage at 150 SSU (32cSt)	5cc per 6.8 Bar (100 PSI) setting
Cartridge Material	All parts steel. All operating parts hardened steel.
Operating Temp. Range/Seals	-34°C to +121°C (Nitrile) (-30°F to +250°F) -26°C to +204°C (Fluorocarbon) (-15°F to +400°F)
Fluid Compatibility/Viscosity	Mineral-based or synthetic with lubricating properties at viscosities of 45 to 2000 SSU (6 to 420 cSt)
Filtration	ISO-4406 18/16/13, SAE Class 4
Approx. Weight	0.34kg (0.75 lbs.)
Cavity	C16-3 (See BC Section for more details)

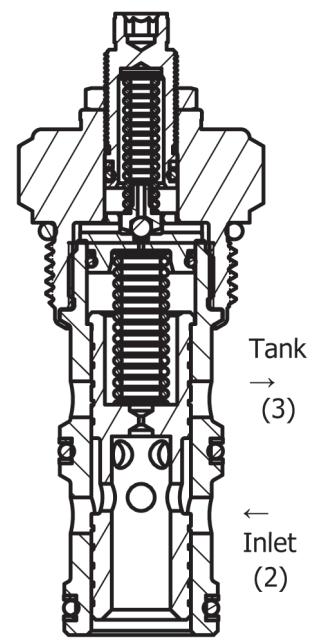
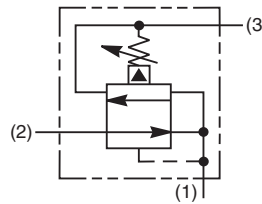

Reg. ↓ (1) ↑ Relief

Performance Curve

Flow vs. Regulated Pressure

(Pressure rise through cartridge only)

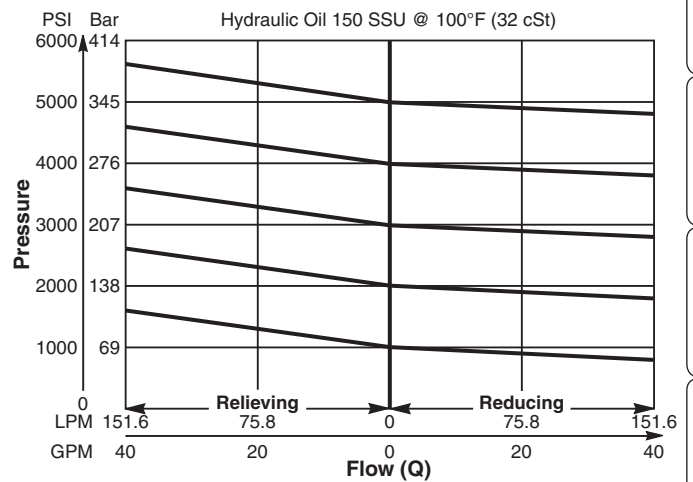

Pressure Drop vs. Flow

(Through cartridge only)

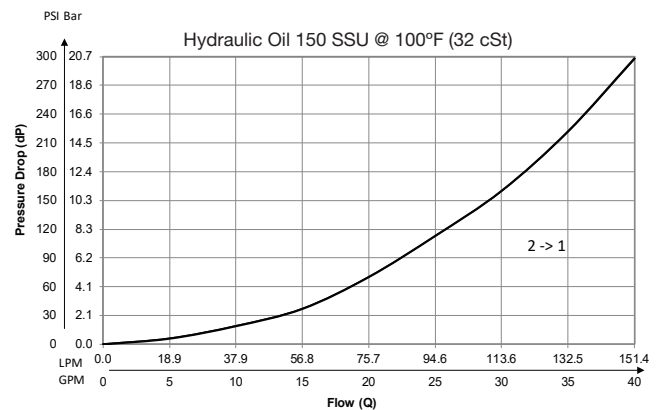

- CV
- Check Valves
- SH
- Shuttle Valves
- LM
- Load/Motor Controls
- FC
- Flow Controls
- PC
- Pressure Controls
- LE
- Logic Elements
- DC
- Directional Controls
- SV
- Solenoid Valves
- PV
- Proportional Valves
- CE
- Coils & Electronics
- BC
- Bodies & Cavities
- TD
- Technical Data

Dimensions Millimeters (Inches)

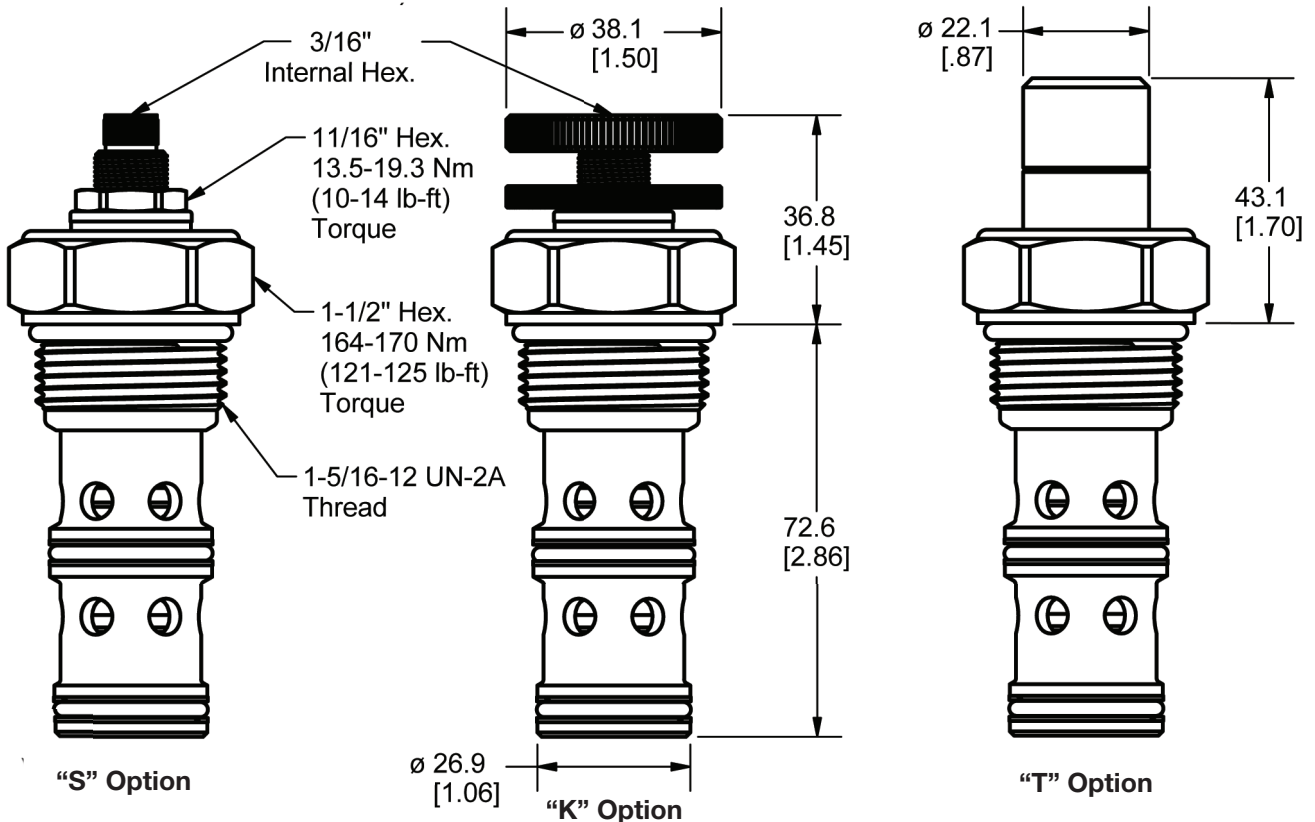

Ordering Information

PRH161 **S**

16 Size P.O. Pressure Reducing/Relieving Valve Adjustment Style Pressure Range

Highlighted represents preferred options that offer the shortest lead times. Other options may be available, but at extended lead times.

Code	Adjustment Style
S	Screw Adjust

Code	Seals
Omit	Nitrile

Code	Pressure Range
10	6.9 - 69 Bar (100 - 1000 PSI) Standard Setting: 34.5 Bar (500 PSI)
30	20.7 - 207 Bar (300 - 3000 PSI) Standard Setting: 103.5 Bar (1500 PSI)
50	34.5 - 345 Bar (500 - 5000 PSI) Standard Setting: 172.4 Bar (2500 PSI)

Kit	Part Number
Knob	717784-15
Tamper Resistant Cap	717785
Nitrile Seal	SK16-3
Fluorocarbon Seal	SK16-3V

Order Bodies Separately
 See section BC

B16 — **3** — **16T**

16 size 3-Way Cavity Port Size

Code	Porting / Body Material
16T	SAE-16 / Steel (5000 PSI)

CV
Check Valves

SH
Shuttle Valves

LM
Load/Motor Controls

FC
Flow Controls

PC
Pressure Controls

LE
Logic Elements

DC
Directional Controls

SV
Solenoid Valves

PV
Proportional Valves

CE
Coils & Electronics

BC
Bodies & Cavities

TD
Technical Data

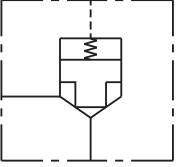
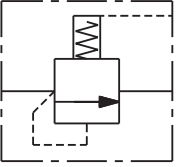
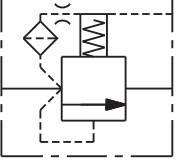
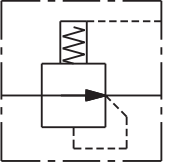
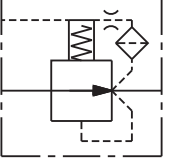
SERIES	CAVITY	DESCRIPTION	FLOW LPM/GPM	PRESSURE BAR/PSI	PAGE NO.
Technical Tips.....					LE2-LE7
POPPET TYPE					
					
LE101A (NEW)	C10-3S	Normally Closed, Pilot to Close	57/15	350/5000	LE8
16SLC1-A	C16-3S	Normally Closed, Pilot to Close	189/50	240/3500	LE9
20SLC1-A	C20-3S	Normally Closed, Pilot to Close	303/80	240/3500	LE10
SPOOL TYPE					
					
LE102A (NEW)	C10-3S	Normally Closed, Pilot to Close	57/15	350/5000	LE11
R06E3	C16-3S	Normally Closed, Pilot to Close	400/106	420/6000	LE12
R08E3	C20-3S	Normally Closed, Pilot to Close	500/132	420/6000	LE13
					
LE102B (NEW)	C10-3S	Normally Closed, Vent to Open	57/15	350/5000	LE14
					
LE103A (NEW)	C10-3S	Normally Open, Vent to Close	57/15	350/5000	LE15
R06H3	C16-3S	Normally Open, Vent to Close	160/42	420/6000	LE16
					
LE103B (NEW)	C10-3S	Normally Open, Vent to Close	57/15	350/5000	LE17

CV

Check Valves

SH

Shuttle Valves

LM

Load/Motor Controls

FC

Flow Controls

PC

Pressure Controls

LE

Logic Elements

DC

Directional Controls

SV

Solenoid Valves

PV

Proportional Valves

CE

Coils & Electronics

BC

Bodies & Cavities

TD

Technical Data

INTRODUCTION:

Parker's logic valves offer system designers a versatile range of screw-in elements that, when used in the proper combinations, can provide flexible design solutions for many common cartridge valve applications. They offer system designers the advantage of applying cartridge valve technology in applications where the flow and pressure conditions may exceed the limits of typical cartridge valves. Logic valves are essentially high flow poppet or spool elements that are controlled by small pilot devices. They can be used to control flow, pressure, or direction, and when applied in the proper arrangements, can perform multi-task control functions. Parker's logic valves offer system designers alternative products that can help reduce the size, cost, and complexity of integrated manifold systems.

NEW PRODUCTS:

Parker Logic Valves are offered in two basic categories: Poppet and Spool.

Poppet Type - Used for flow switching directional control applications.

Spool Type - Used for pressure sensing in modulating applications to regulate flow and pressure.

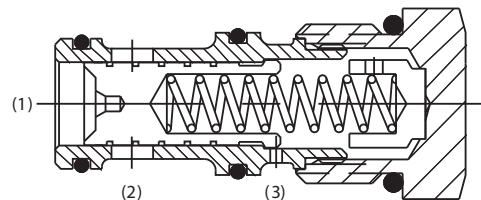
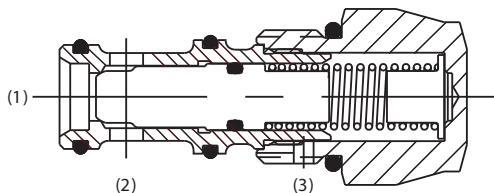

PRODUCT TYPES / APPLICATIONS
POPPET TYPE

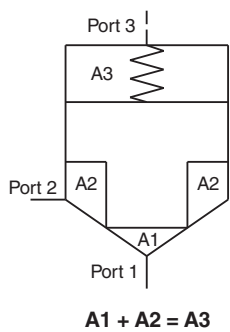

Poppet type logic valves are 3 ported, 2-way on/off valves that switch flow between port 1 and port 2. The poppet's on/off action is operated by controlling pilot oil at port 3 of the valve. A small low flow solenoid or pilot valve is an ideal control for this purpose. Parker offers vent-to-open and pilot-to-close style poppet logic valves.

Note: Poppet logic valves are an unbalanced 2:1 ratio poppet design. The opening and closing of the poppet is dependent on the force balances on the areas of the poppet at port 1, port 2, and port 3.

Vent-to-open logic valves:

Vent-to-open logic valves are primarily used for uni-directional switching applications. The poppet in the vent-to-open logic valve is spring biased to the closed condition. The pilot oil source that operates the logic element is generated internally by direct pressure from either work port 1 or 2, depending on the option chosen. Venting the pilot oil at port 3 allows the valve to open and pass flow between port 1 and 2 at the bias spring setting. Blocking the pilot at port 3 causes the valve to close. When closed, the 2:1 ratio poppet design provides a positive low leak seal. Because the pilot source is generated internally within the valve, vent-to-open logic valves are best suited for uni-directional applications.

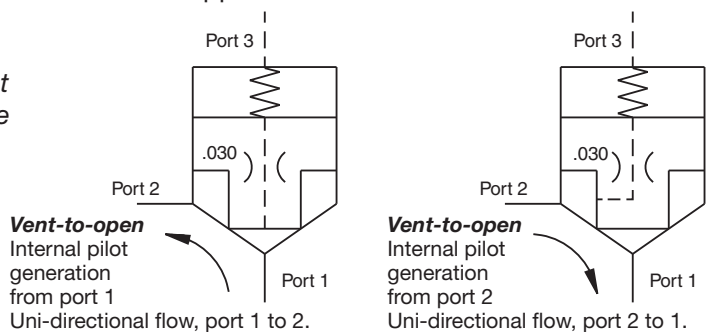

Technical Tips

POPPET TYPE *Continued*

Pilot-to-close logic valve:

Pilot-to-close logic elements are primarily used for bi-directional flow switching applications. The poppet in the pilot-to-close logic valve is spring biased to the closed condition. With no pilot signal at port 3, the valve will open allowing flow in either direction between work ports 1 and 2 once pressure at one of the work ports reaches the biased spring setting. Applying a sufficient externally generated pilot force to port 3 of the valve closes the poppet creating a low leak seal between port 1 and port 2.

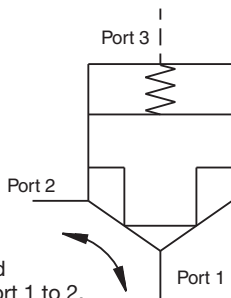

Pilot-to-close
External pilot required
Bi-directional flow, port 1 to 2.

Logic Elements

2-way, 3-way, and 4-way Directional Control:

Poppet logic valves are typically used to perform high flow directional switching operations using small low power pilot valves to control the sequence of the directional operation.

- A single logic valve can be used to control 2-way, on/off switching.
- Multiple elements in a bridge arrangement can control 3-way or 4-way directional switching.
- Since each logic valve is individually controlled, the timing, sequence, and overlap of directional functions can be controlled very precisely.
- Uni-directional or bi-directional flow can be achieved, depending on the valve selected.
- Flows in excess of 80 gpm can be controlled through a single logic element, and more than one logic valve can be used in parallel to control flow in excess of the rated flow of a single element.
- Poppet construction provides a low leak directional control.

(See circuit examples on pages LE5-LE6)

SPOOL TYPE

Spool type logic valves can also be used for directional switching, however, they are typically used in modulating applications to control flow or regulate pressure. Virtually any pressure or flow control function can be achieved with a spool type logic valve including; restrictive or priority flow control, pressure relief, pressure reducing, sequencing, and unloading.

The spools in this category of logic valves are balanced designs; the spool area at the work port (port 1) and the pilot port (port 3) are equal (1:1). The spool is held in a biased condition by a spring. Venting the pilot at port 3 creates an unbalanced condition causing the valve spool to modulate open or close, depending on the valve chosen. This spool design makes the valve vary stable because the forces acting to open and close the valve are in balance.

Flow Control / Compensators:

Parker offers two types of logic valves for flow control functions.

- 1) Normally open spools function as a restrictive type compensator.
- 2) Normally closed spools function as a priority or by-pass compensator.

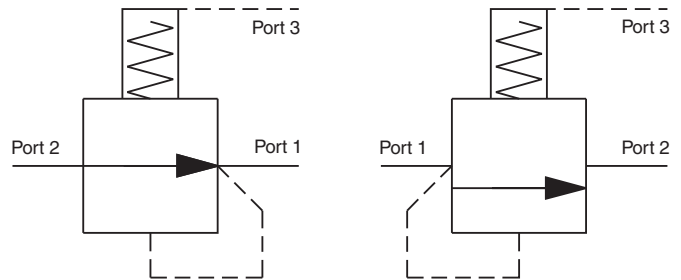

Normally open spool

Normally closed spool

CV
Check Valves
SH
Shuttle Valves
LM
Load/Motor Controls
FC
Flow Controls
PC
Pressure Controls
LE
Logic Elements
DC
Directional Controls
SV
Solenoid Valves
PV
Proportional Valves
CE
Coils & Electronics
BC
Bodies & Cavities
TD
Technical Data

Technical Tips

Restrictive Flow Regulator:

Normally open spool type logic elements can be used with an external orifice or valve as a compensator to regulate flow. Used as restrictive compensator, a normally open spool senses the upstream and downstream pressure across an orifice or valve. The spool modulates closed to maintain a constant pressure drop across the controlled device equal to the bias spring in the logic valve, thus maintaining a constant flow rate regardless of changes in upstream or downstream pressure.

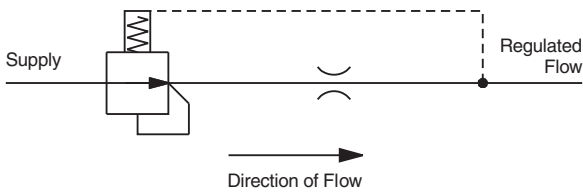

Logic Elements

Priority / Bypass Flow Regulator:

A logic valve with a normally closed spool can be used as a priority or by-pass compensator. In this case, the spool modulates open to maintain a constant pressure drop across the controlled orifice or valve, thereby maintaining a constant priority flow regardless of upstream or downstream pressure changes. In a priority arrangement, any oil that doesn't saturate the controlled device is by-passed plus the value of the bias spring in the logic valve.

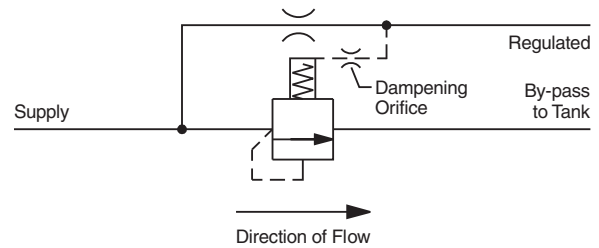

Pressure Control:

Spool type logic valves can be used as the main stage spool in high flow pressure control applications with the logic valve handling the high flow, and a small pilot valve controlling the action of the logic valve spool. Normally open, and normally closed spool options are available enabling virtually all pressure control functions to be achieved. When used in pressure control applications, the logic valve spool modulates open or closed to maintain the pressure setting of the pilot valve communicated to port 3. Pressure control applications require a pilot connection between the control port (port 1 or 2), and the pilot port (port 3). In order to simplify the design, Parker offers spool type logic valves with internal piloting options that can help minimize the number of connections needed. When used in manifold systems, the internal piloting options help to simplify the manifold design by reducing the number of construction drillings in the block. Multiple functions such as relief, pump unloading, and pressure compensation can be performed with one logic valve by communicating multiple pilot devices to the same logic element.

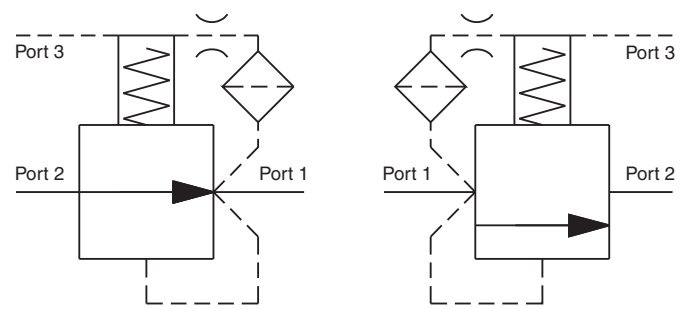

Normally open spool

- Pressure Reducing

Normally closed spool

- Relief
- Sequence
- Unloading

(See circuit examples on page LE7)

Application Note:

This section is as an application guide, and it is intended to illustrate the various ways that logic elements can be used to create a variety of hydraulic control functions. For additional help applying logic valves, contact your Parker Sales Engineer.

CV
Check Valves

SH
Shuttle Valves

LM
Load/Motor Controls

FC
Flow Controls

PC
Pressure Controls

LE
Logic Elements

DC
Directional Controls

SV
Solenoid Valves

PV
Proportional Valves

CE
Coils & Electronics

BC
Bodies & Cavities

TD
Technical Data

DIRECTIONAL CONTROL EXAMPLES

2-position, 2-way normally open example.
Switched by 2-position, 3-way pilot valve and external pilot pressure.

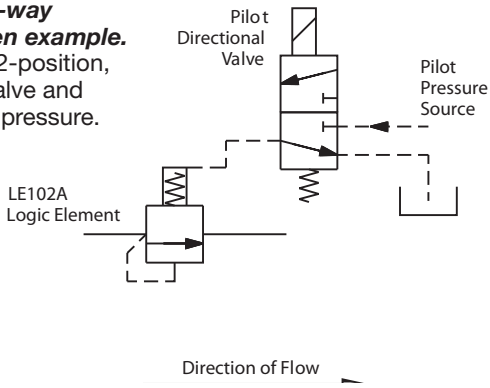

2-position, 2-way normally open example.
Switched by external pilot pressure and vented through 2-position, 2-way pilot valve.

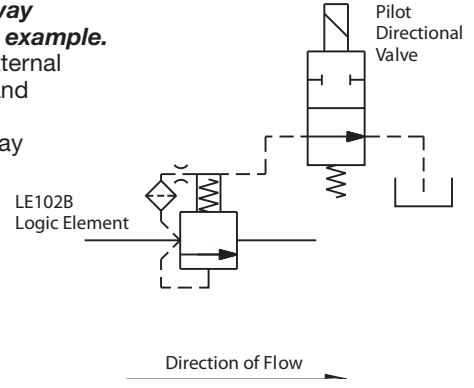

2-position, 2-way normally open example.
Internal pilot generation.

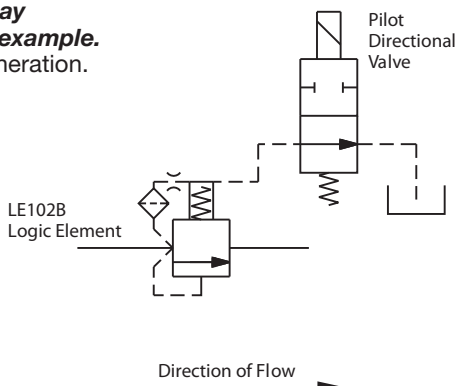

2-position, 2-way normally open example.
Internal pilot generation.

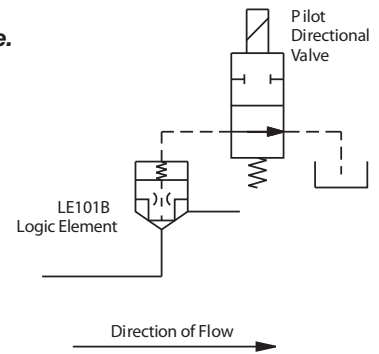

2-position, 2-way normally open example.
Switched by 2-position, 3-way pilot valve and external pilot.

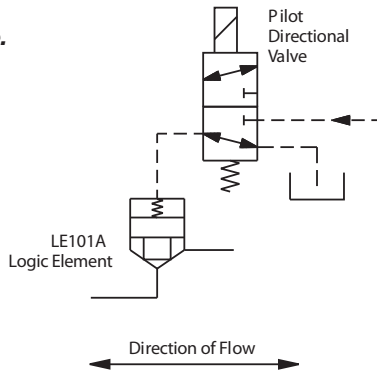

****SLC1A logic element.**
With shuttle-selected pilot supply.

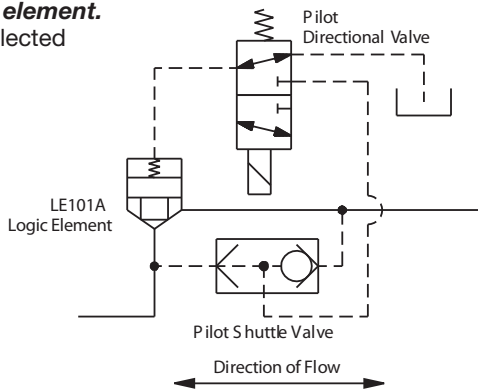

****SLC1A logic element.**
External pilot supply and 2-position, 2-way pilot directional valve.

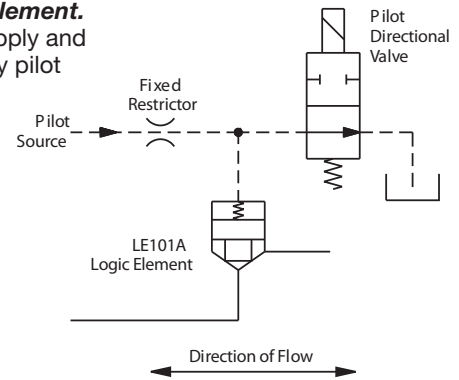

CV
Check Valves
SH
Shuttle Valves
LM
Load/Motor Controls
FC
Flow Controls
PC
Pressure Controls
LE
Logic Elements
DC
Directional Controls
SV
Solenoid Valves
PV
Proportional Valves
CE
Coils & Electronics
BC
Bodies & Cavities
TD
Technical Data

DIRECTIONAL CONTROL EXAMPLES

THREE-WAY BRIDGE CIRCUITS

Circuit 1, with LE101A poppet logic element.

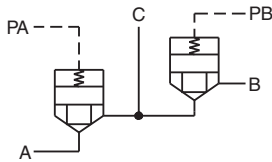

Circuit 2, with LE102A spool logic element.

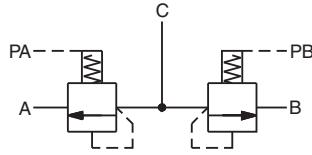

Circuit 3, with LE102A spool logic element.

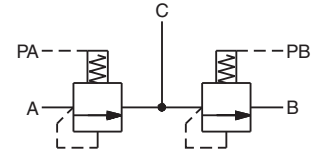

Required Flow Path	Pilot Pressure Applied To		Available From Circuit			Required Flow Path	Pilot Pressure Applied To		Available From Circuit		
	PA	PB	1	2	3		PA	PB	1	2	3
	NO	NO	X	X			NO	YES	X	X	
	YES	NO	X	X	X		NO	YES	X		X

NOTE: Pilot pressure must exceed load pressure in order for valve to close.

FOUR-WAY BRIDGE CIRCUITS

Circuit 1, with LE101A poppet logic elements.

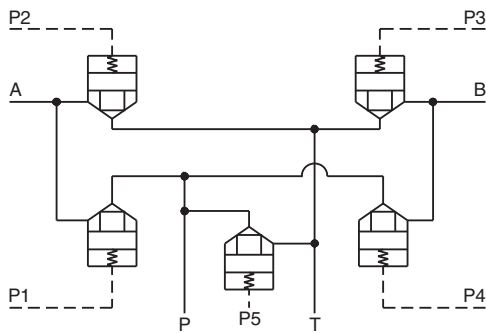

Circuit 2, with LE102A spool logic elements.

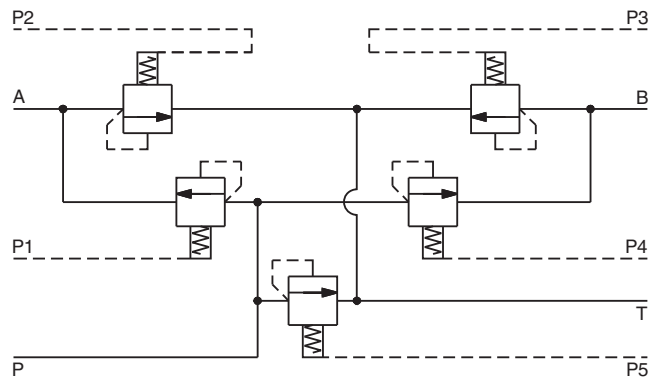

Required Flow Path	Pilot Pressure Applied To					Required Flow Path	Pilot Pressure Applied To					Required Flow Path	Pilot Pressure Applied To				
	P1	P2	P3	P4	P5		P1	P2	P3	P4	P5		P1	P2	P3	P4	P5
	YES	YES	YES	YES	YES		YES	NO	NO	YES	YES		YES	NO	YES	NO	YES
	NO	NO	NO	NO	NO		NO	YES	YES	NO	YES		YES	YES	YES	NO	YES
	YES	YES	NO	NO	NO		YES	YES	NO	YES	YES		YES	NO	YES	YES	YES
	NO	NO	YES	YES	NO		NO	YES	YES	YES	YES						
	YES	YES	YES	YES	NO		NO	YES	NO	YES	YES						

NOTE: Pilot pressure must exceed load pressure in order for valve to close.

FLOW CONTROL EXAMPLES

Pressure compensated priority flow control example.

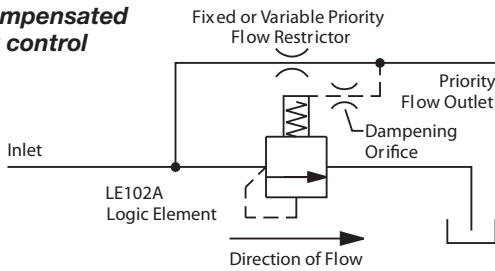

Load sensing priority flow control example with pressure limiting and unloading.

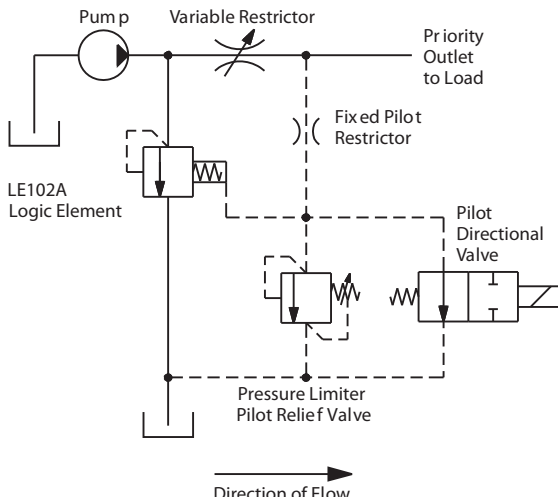

Pressure compensated restrictive flow control example.

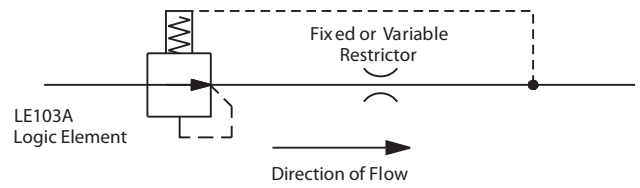

Load sensing priority flow control example with pressure limiter.

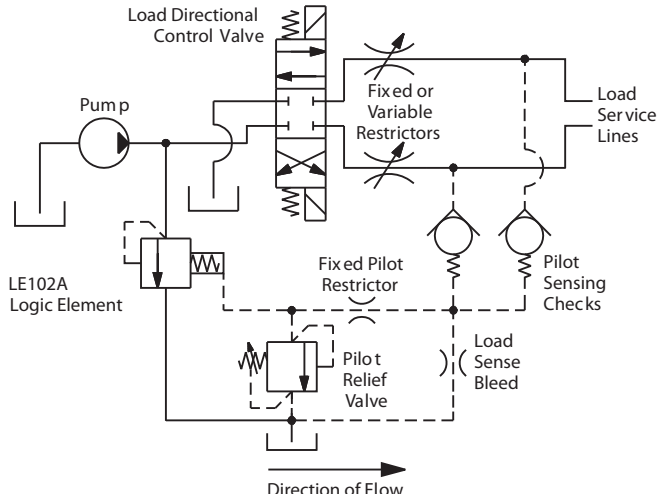

PRESSURE CONTROL EXAMPLES

Pressure relief or sequence example with external pilot supply and pilot relief.

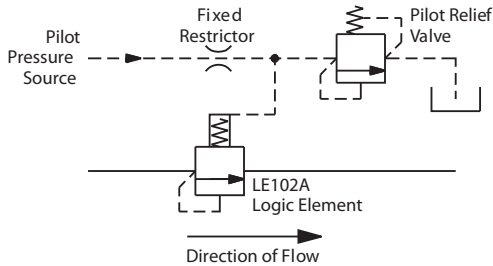

Pressure reducing example, non-relieving type.

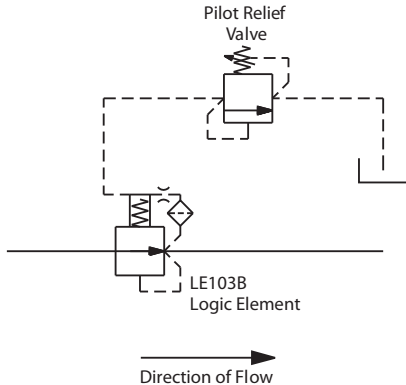

Pressure relief or sequence example with internal pilot supply and pilot relief.

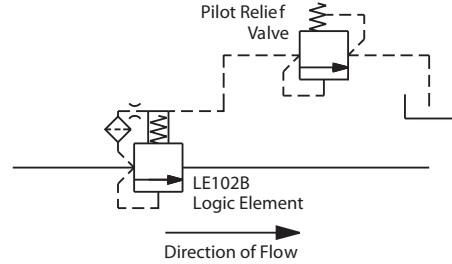

Pressure reducing-relieving example.

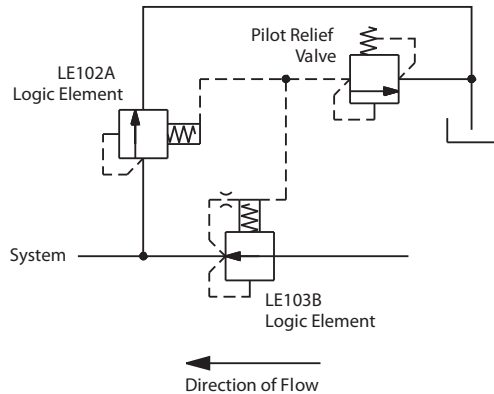

CV
Check Valves
SH
Shuttle Valves
LM
Load/Motor Controls
FC
Flow Controls
PC
Pressure Controls
LE
Logic Elements
DC
Directional Controls
SV
Solenoid Valves
PV
Proportional Valves
CE
Coils & Electronics
BC
Bodies & Cavities
TD
Technical Data

General Description

Poppet Type, Bi-Directional, Normally Closed, Pilot to Close Logic Element. For additional information see Technical Tips on pages LE2-LE7.

Features

- Hardened, precision ground parts for durability
- Low leakage design
- All external parts zinc plated
- Port 2 to 1 is the preferred flow path
- “D”-Ring eliminates backup rings

Specifications

Rated Flow	57 LPM (15 GPM)
Maximum Inlet Pressure	350 Bar (5000 PSI)
Leakage at 150 SSU (32 cSt)	5 drops/min. (.33 cc/min.) @ 240 Bar (3500 PSI)
Cartridge Material	All parts steel. All operating parts hardened steel.
Operating Temp. Range/Seals	-37°C to +93°C (“D”-Ring) (-35°F to +200°F) -34°C to +121°C (Nitrile) (-30°F to +250°F) -26°C to +204°C (Fluorocarbon) (-15°F to +400°F)
Fluid Compatibility/Viscosity	Mineral-based or synthetic with lubricating properties at viscosities of 45 to 2000 SSU (6 to 420 cSt)
Filtration	ISO-4406 18/16/13, SAE Class 4
Approx. Weight	0.14 kg (0.3 lbs.)
Cavity	C10-3S (See BC Section for more details)

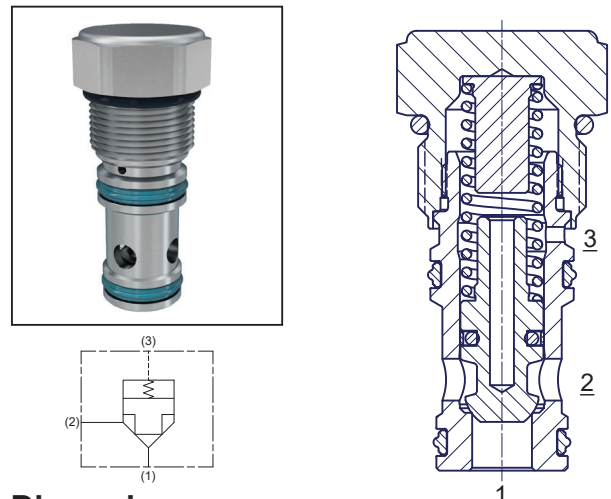

Dimensions

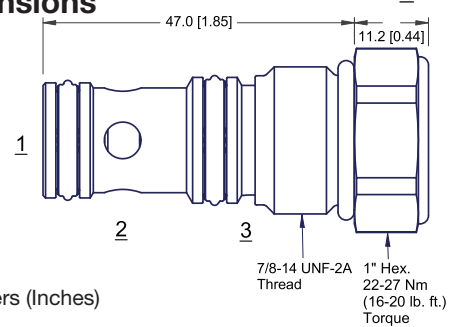

Millimeters (Inches)

Performance Curves

**Pressure Drop, P2-P1 vs. Flow (Through cartridge only)
 Hydraulic Oil 150 SSU @ 100F (32cSt)**

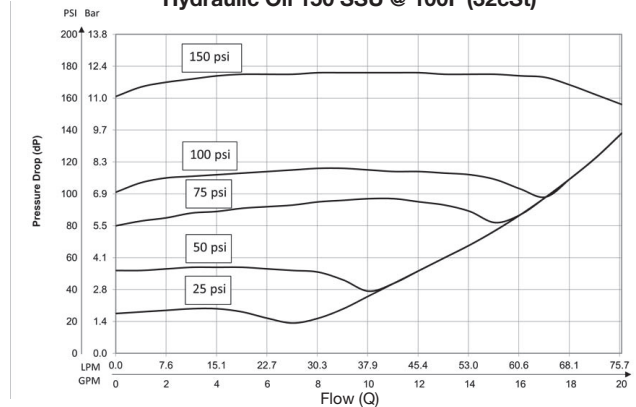

**Pressure Drop, P1-P2 vs. Flow (Through cartridge only)
 Hydraulic Oil 150 SSU @ 100F (32cSt)**

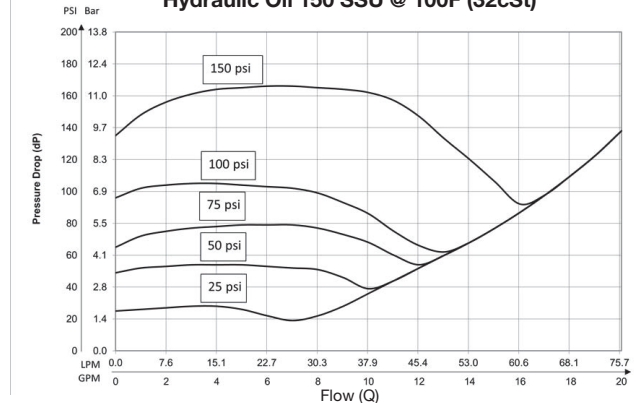

Ordering Information

LE101A	<input type="checkbox"/>
10 Size Logic Element	Bias Spring

Highlighted represents preferred options that offer the shortest lead times. Other options may be available, but at extended lead times.

Code	Bias Spring	Code	Seals
02	1.7 Bar (25 PSI)	Omit	“D-Ring”
04	3.5 Bar (50 PSI)		
05	5.2 Bar (75 PSI)		
07	6.9 Bar (100 PSI)		
10	10.3 Bar (150 PSI)		

Kit	Part Number
D-Ring Seal	SK10-3S
Nitrile Seal	SK10-3S
Fluorocarbon Seal	SK10-3SV

General Description

Poppet Type, Bi-Directional, Normally Closed, Pilot to Close Logic Element. For additional information see Technical Tips on pages LE2-LE7.

Features

- Hardened, precision ground parts for durability
- Polyurethane seals only
- No backup rings
- Low leakage design
- All external parts zinc plated
- Port 2 to 1 is the preferred flow path

Performance Curve

Pressure Drop vs. Flow (Through cartridge only)

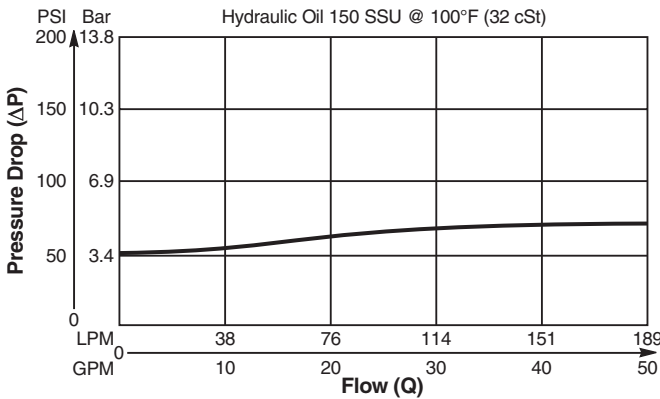

Specifications

Rated Flow	189 LPM (50 GPM)
Maximum Inlet Pressure	240 Bar (3500 PSI)
Leakage at 150 SSU (32 cSt)	5 drops/min. (.33 cc/min.) @ 240 Bar (3500 PSI)
Cartridge Material	All parts steel. All operating parts hardened steel.
Operating Temp. Range/Seals	-37°C to +107°C (Polyurethane, EPS) (-35°F to +225°F) -26°C to +204°C (Fluorocarbon) (-15°F to +400°F)
Fluid Compatibility/Viscosity	Mineral-based or synthetic with lubricating properties at viscosities of 45 to 2000 SSU (6 to 420 cSt)
Filtration	ISO-4406 18/16/13, SAE Class 4
Approx. Weight	0.33 kg (0.78 lbs.)
Cavity	C16-3S (See BC Section for more details)

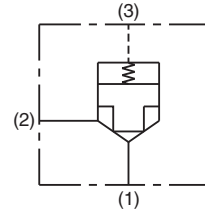
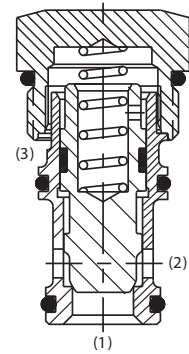

Dimensions Millimeters (Inches)

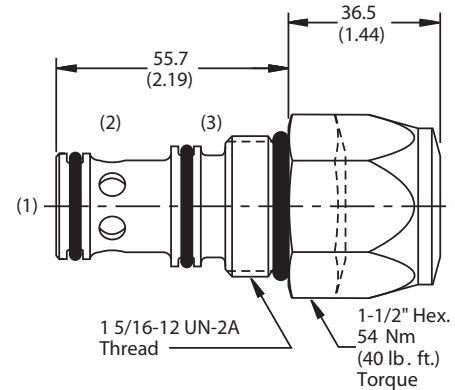

Ordering Information

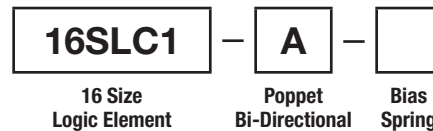

Highlighted represents preferred options that offer the shortest lead times. Other options may be available, but at extended lead times.

Code	Bias Spring
100	6.9 Bar (100 PSI)
150	10.3 Bar (150 PSI)

Code	Seals
Omit	Polyurethane, EPS

Kit	Part Number
Polyurethane, EPS Seal	WRK-16-3S
Fluorocarbon Seal	WRK-16-3S-W

CV	Check Valves
SH	Shuttle Valves
LM	Load/Motor Controls
FC	Flow Controls
PC	Pressure Controls
LE	Logic Elements
DC	Directional Controls
SV	Solenoid Valves
PV	Proportional Valves
CE	Coils & Electronics
BC	Bodies & Cavities
TD	Technical Data

General Description

Poppet Type, Bi-Directional, Normally Closed, Pilot to Close Logic Element. For additional information see Technical Tips on pages LE2-LE7.

Features

- Hardened, precision ground parts for durability
- Polyurethane seals only
- No backup rings
- Low leakage design
- All external parts zinc plated
- Port 2 to 1 is the preferred flow path

Performance Curve

Pressure Drop vs. Flow (Through cartridge only)

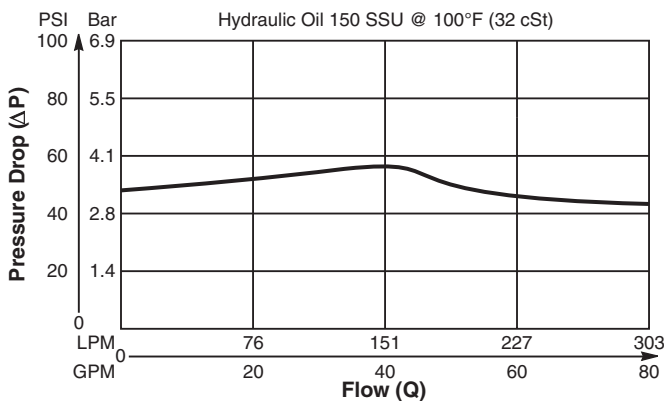

Specifications

Rated Flow	303 LPM (80 GPM)
Maximum Inlet Pressure	240 Bar (3500 PSI)
Leakage at 150 SSU (32 cSt)	5 drops/min. (.33 cc/min.) @ 240 Bar (3500 PSI)
Cartridge Material	All parts steel. All operating parts hardened steel.
Operating Temp. Range/Seals	-37°C to +107°C (Polyurethane, EPS) (-35°F to +225°F) -26°C to +204°C (Fluorocarbon) (-15°F to +400°F)
Fluid Compatibility/Viscosity	Mineral-based or synthetic with lubricating properties at viscosities of 45 to 2000 SSU (6 to 420 cSt)
Filtration	ISO-4406 18/16/13, SAE Class 4
Approx. Weight	0.81 kg (1.78 lbs.)
Cavity	C20-3S (See BC Section for more details)

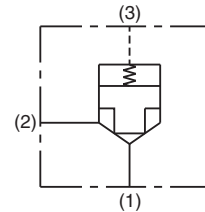
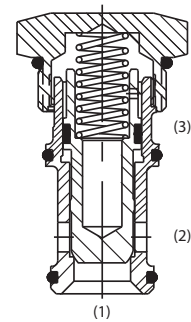

Dimensions Millimeters (Inches)

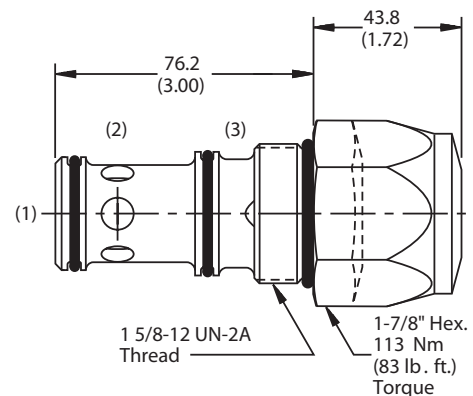

Ordering Information



Highlighted represents preferred options that offer the shortest lead times. Other options may be available, but at extended lead times.

Code	Bias Spring
100	6.9 Bar (100 PSI)
150	10.3 Bar (150 PSI)

Code	Seals
Omit	Polyurethane, EPS

Kit	Part Number
Polyurethane, EPS Seal	WRK-20-3S
Fluorocarbon Seal	WRK-20-3S-W

CV	Check Valves
SH	Shuttle Valves
LM	Load/Motor Controls
FC	Flow Controls
PC	Pressure Controls
LE	Logic Elements
DC	Directional Controls
SV	Solenoid Valves
PV	Proportional Valves
CE	Coils & Electronics
BC	Bodies & Cavities
TD	Technical Data

General Description

Spool Type, Normally Closed, Pilot to Close Logic Element. For additional information see Technical Tips on pages LE2-LE7.

Features

- High flow capacity
- Used as high flow switching or metering element
- Can be used as bleed off style pressure compensated flow regulator when used with restrictor
- Various bias spring pressures available
- 1:1 pilot pressure ratio
- Hardened working parts for maximum durability
- All external parts zinc plated
- “D”-Ring eliminates backup rings

Performance Curve

Pressure Drop, vs. Flow (Through cartridge only)
Hydraulic Oil 150 SSU @ 100F (32cSt)

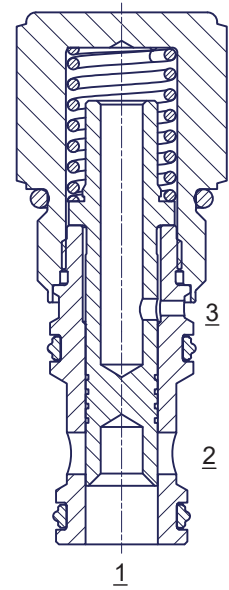
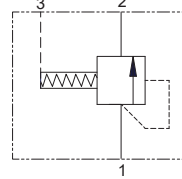
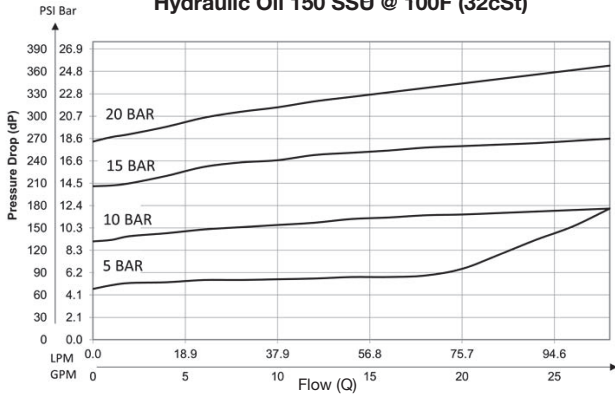

Dimensions Millimeters (Inches)

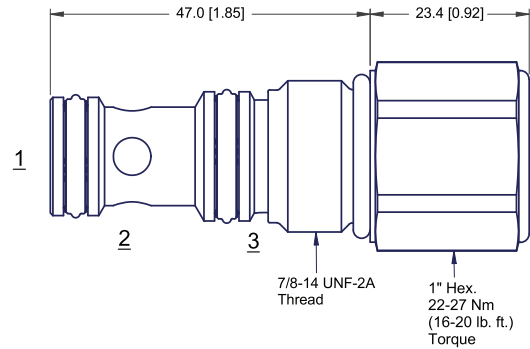

Specifications

Rated Flow	57 LPM (15 GPM)
Maximum Inlet Pressure	350 Bar (5000 PSI)
Leakage at 150 SSU (32 cSt)	82 ml/min. @207 Bar (3000 PSI)
Cartridge Material	All parts steel. All operating parts hardened steel.
Operating Temp. Range/Seals	-37°C to +93°C (“D”-Ring) (-35°F to +200°F) -34°C to +121°C (Nitrile) (-30°F to +250°F) -26°C to +204°C (Fluorocarbon) (-15°F to +400°F)
Fluid Compatibility/Viscosity	Mineral-based or synthetic with lubricating properties at viscosities of 45 to 2000 SSU (6 to 420 cSt)
Filtration	ISO-4406 18/16/13, SAE Class 4
Approx. Weight	0.02 kg (0.045 lbs.)
Cavity	C10-3S (See BC Section for more details)

Ordering Information

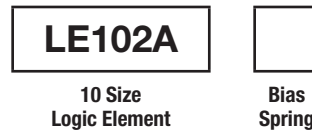

Highlighted represents preferred options that offer the shortest lead times. Other options may be available, but at extended lead times.

Code	Bias Spring
01	1.7 Bar (25 PSI)
05	3.5 Bar (50 PSI)
07	6.9 Bar (100 PSI)
10	10.3 Bar (150 PSI)
15	15 Bar (218 PSI)
20	20 Bar (290 PSI)

Code	Seals
Omit	“D-Ring”

Kit	Part Number
D-Ring Seal	SK10-3S
Nitrile Seal	SK10-3S
Fluorocarbon Seal	SK10-3SV

General Description

Spool Type, Normally Closed, Pilot to Close Logic Element. For additional information see Technical Tips on pages LE2-LE7.

Features

- High flow capacity
- Used as high flow switching or metering element
- Can be used as bleed off style pressure compensated flow regulator when used with restrictor
- More stable than poppet type
- Various switching pressures available
- 1:1 pilot pressure ratio
- Hardened working parts for maximum durability
- All external parts zinc plated

Performance Curve (Through cartridge only)
Vented Open Pressure Drop vs. Flow 1 to 2

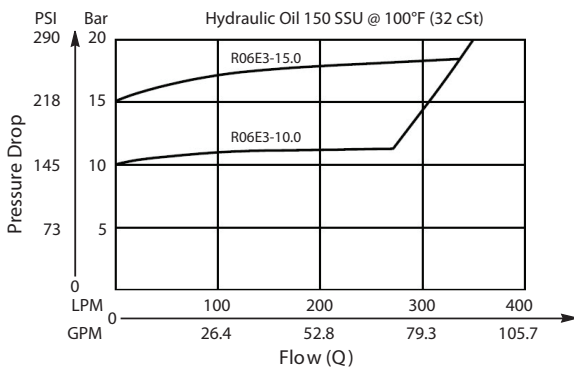

Specifications

Rated Flow	400 LPM (106 GPM)
Nominal Flow @ 7 Bar (100 PSI)	270 LPM (71 GPM)
Maximum Inlet Pressure	420 Bar (6000 PSI)
Leakage at 150 SSU (32 cSt)	82cc/min. (5 cu in./min.) @ 240 Bar (3000 PSI)
Cartridge Material	All parts steel. All operating parts hardened steel.
Operating Temp. Range/Seals	-34°C to +121°C (Nitrile) (-30°F to +250°F) -26°C to +204°C (Fluorocarbon) (-15°F to +400°F)
Fluid Compatibility/Viscosity	Mineral-based or synthetic with lubricating properties at viscosities of 45 to 2000 SSU (6 to 420 cSt)
Filtration	ISO-4406 18/16/13, SAE Class 4
Approx. Weight	0.33 kg (0.78 lbs.)
Cavity	C16-3S (See BC Section for more details)

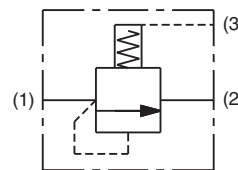
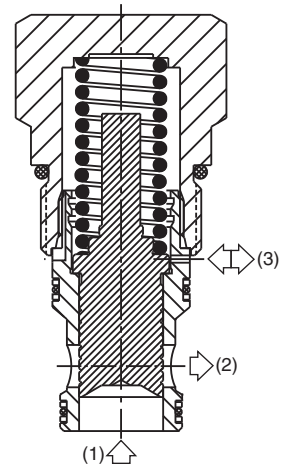

Dimensions Millimeters (Inches)

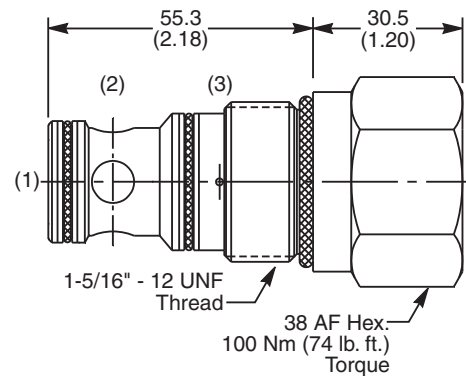

Ordering Information

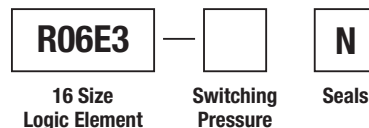

Code	Switching Pressure Non Adjustable Preset
10.0	10.0 Bar (145 PSI)
15.0	15.0 Bar (218 PSI)

Code	Seals
N	Nitrile

Kit	Part Number
Nitrile Seal	SK30508N-1
Fluorocarbon Seal	SK30508V-1

CV
Check Valves
SH
Shuttle Valves
LM
Load/Motor Controls
FC
Flow Controls
PC
Pressure Controls
LE
Logic Elements
DC
Directional Controls
SV
Solenoid Valves
PV
Proportional Valves
CE
Coils & Electronics
BC
Bodies & Cavities
TD
Technical Data

General Description

Spool Type, Normally Closed, Pilot to Close Logic Element. For additional information see Technical Tips on pages LE2-LE7.

Features

- High flow capacity
- Can be used as high flow switching or metering element
- Can be used as bleed off style pressure compensated flow regulator when used with restrictor
- Various switching pressures available
- 1:1 pilot pressure ratio
- Hardened working parts for maximum durability
- All external parts zinc plated

Performance Curve (Through cartridge only)
Vented Open Pressure Drop vs. Flow 1 to 2

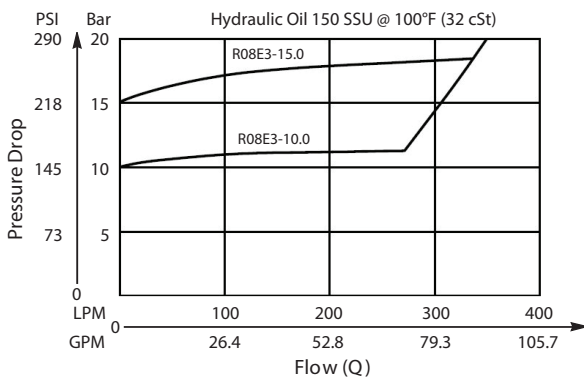

Specifications

Rated Flow	500 LPM (132 GPM)
Nominal Flow @ 7 Bar (100 PSI)	340 LPM (90 GPM)
Maximum Inlet Pressure	420 Bar (6000 PSI)
Leakage at 150 SSU (32 cSt)	82ml/min. @ 240 Bar (3000 PSI)
Cartridge Material	All parts steel. All operating parts hardened steel.
Operating Temp. Range/Seals	-34°C to +121°C (Nitrile) (-30°F to +250°F) -26°C to +204°C (Fluorocarbon) (-15°F to +400°F)
Fluid Compatibility/Viscosity	Mineral-based or synthetic with lubricating properties at viscosities of 45 to 2000 SSU (6 to 420 cSt)
Filtration	ISO-4406 18/16/13, SAE Class 4
Approx. Weight	0.69 kg (1.52 lbs.)
Cavity	C20-3S (See BC Section for more details)

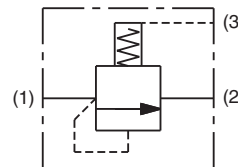
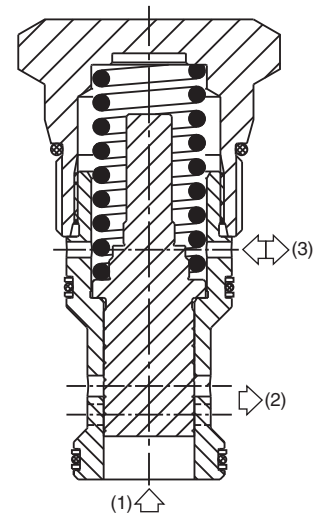
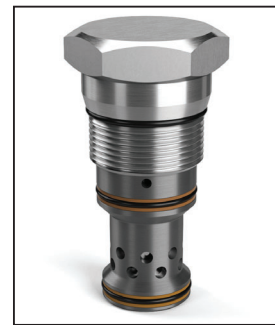

Dimensions Millimeters (Inches)

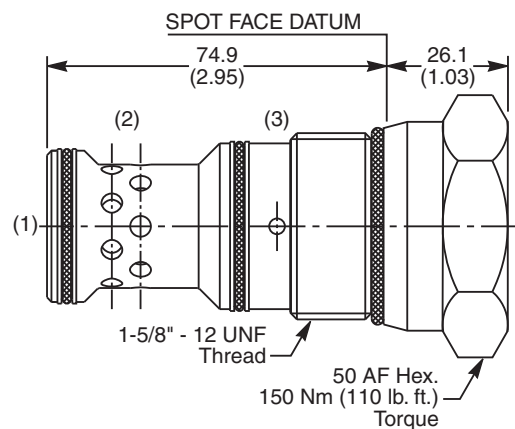

Ordering Information

R08E3		N
20 Size Logic Element	Switching Pressure	Seals

Code	Switching Pressure Non Adjustable Preset
10.0	10.0 Bar (145 PSI)
15.0	15.0 Bar (218 PSI)

Code	Seals
N	Nitrile

Kit	Part Number
Nitrile Seal	SK30512N-1
Fluorocarbon Seal	SK30512V-1

CV
Check Valves
SH
Shuttle Valves
LM
Load/Motor Controls
FC
Flow Controls
PC
Pressure Controls
LE
Logic Elements
DC
Directional Controls
SV
Solenoid Valves
PV
Proportional Valves
CE
Coils & Electronics
BC
Bodies & Cavities
TD
Technical Data

General Description

Spool Type, Normally Closed, Vent to Open Logic Element. For additional information see Technical Tips on pages LE2-LE7.

Features

- High flow capacity
- Used as high flow switching or metering element
- Can be used as main stage for a pilot operated relief or sequence valve
- Integral pilot flow filter
- Various bias spring pressures available
- 1:1 pilot pressure ratio
- Hardened working parts for maximum durability
- All external parts zinc plated
- “D”-Ring eliminates backup rings

Performance Curve

Pressure Drop, vs. Flow (Through cartridge only)
 Hydraulic Oil 150 SSU @ 100F (32cSt)

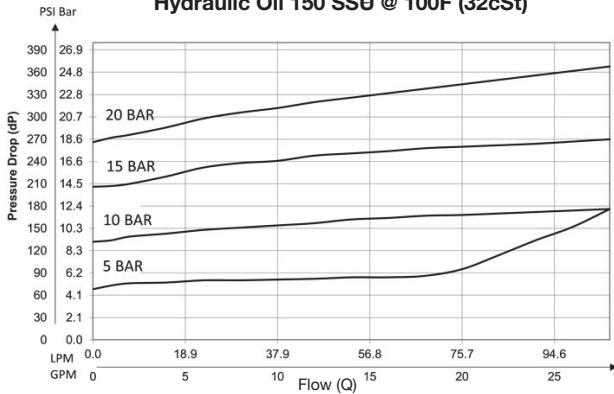

Specifications

Rated Flow	57 LPM (15 GPM)
Maximum Inlet Pressure	350 Bar (5000 PSI)
Leakage @ 150 SSU (32 cst)	82 ml/min. @207 Bar (3000 PSI)
Cartridge Material	All parts steel. All operating parts hardened steel.
Operating Temp. Range/Seals	-37°C to +93°C (“D”-Ring) (-35°F to +200°F) -34°C to +121°C (Nitrile) (-30°F to +250°F) -26°C to +204°C (Fluorocarbon) (-15°F to +400°F)
Fluid Compatibility/Viscosity	Mineral-based or synthetic with lubricating properties at viscosities of 45 to 2000 SSU (6 to 420 cSt)
Filtration	ISO-4406 18/16/13, SAE Class 4
Approx. Weight	.14 kg (.30 lbs.)
Cavity	C10-3S (See BC Section for more details)

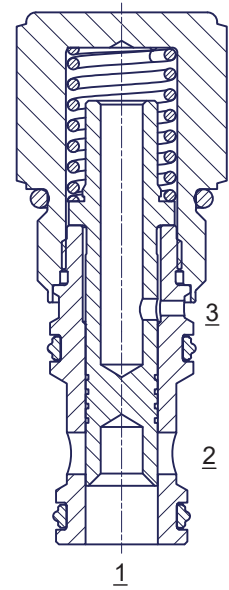
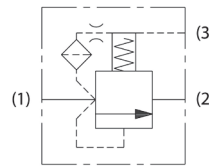

Dimensions Millimeters (Inches)

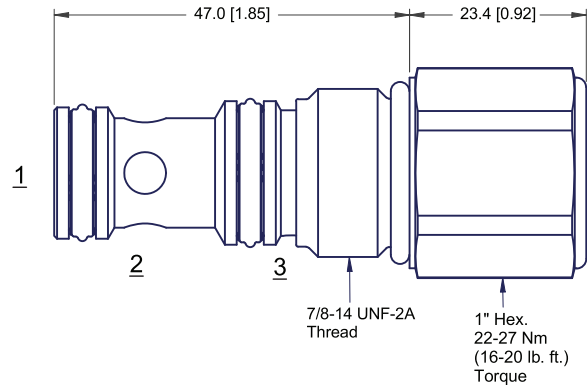

Ordering Information

LE102B **10 Size Logic Element** **Bias Spring**

Highlighted represents preferred options that offer the shortest lead times. Other options may be available, but at extended lead times.

Code	Bias Spring
01	1.7 Bar (25 PSI)
05	3.5 Bar (50 PSI)
07	6.9 Bar (100 PSI)
10	10.3 Bar (150 PSI)
15	15 Bar (218 PSI)
20	20 Bar (290 PSI)

Code	Seals
Omit	“D-Ring”

Kit	Part Number
D-Ring Seal	SK10-3S
Nitrile Seal	SK10-3S
Fluorocarbon Seal	SK10-3SV

CV Check Valves

SH Shuttle Valves

LM Load/Motor Controls

FC Flow Controls

PC Pressure Controls

LE Logic Elements

DC Directional Controls

SV Solenoid Valves

PV Proportional Valves

CE Coils & Electronics

BC Bodies & Cavities

TD Technical Data

General Description

Spool Type, Normally Open, Vent to Close Logic Element. For additional information see Technical Tips on pages LE2-LE7.

Features

- High flow capacity
- Used as high flow switching or metering element
- Can be used for inline pressure compensated flow control when used with restrictor (refer to application)
- Various bias spring pressures available
- 1:1 pilot pressure ratio
- Hardened working parts for maximum durability
- All external parts zinc plated
- “D”-Ring eliminates backup rings

Performance Curve

Pressure Drop, vs. Flow (Through cartridge only)
Hydraulic Oil 150 SSU @ 100F (32cSt)

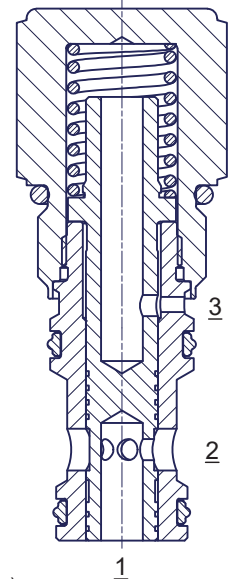
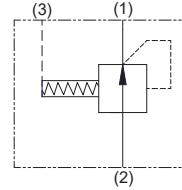
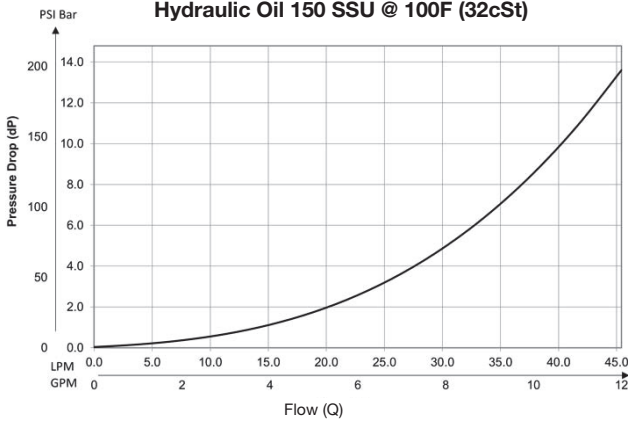

Dimensions Millimeters (Inches)

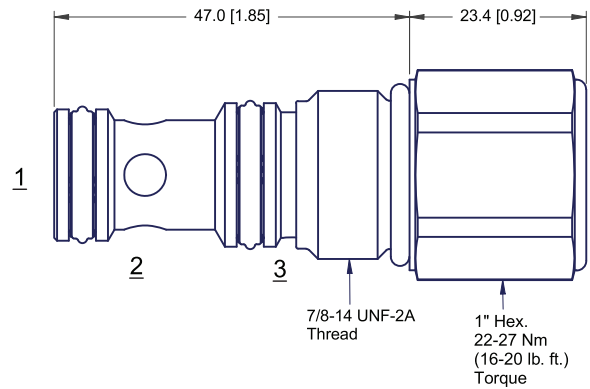

Specifications

Rated Flow	57 LPM (15 GPM)
Maximum Inlet Pressure	350 Bar (5000 PSI)
Leakage at 150 SSU (32 cSt)	82 ml/min. @207 Bar (3000 PSI)
Cartridge Material	All parts steel. All operating parts hardened steel.
Operating Temp. Range/Seals	-37°C to +93°C (“D”-Ring) (-35°F to +200°F) -34°C to +121°C (Nitrile) (-30°F to +250°F) -26°C to +204°C (Fluorocarbon) (-15°F to +400°F)
Fluid Compatibility/Viscosity	Mineral-based or synthetic with lubricating properties at viscosities of 45 to 2000 SSU (6 to 420 cSt)
Filtration	ISO-4406 18/16/13, SAE Class 4
Approx. Weight	0.14 kg (0.3 lbs.)
Cavity	C10-3S (See BC Section for more details)

Ordering Information



Highlighted represents preferred options that offer the shortest lead times. Other options may be available, but at extended lead times.

Code	Bias Spring
01	1.7 Bar (25 PSI)
05	3.5 Bar (50 PSI)
07	6.9 Bar (100 PSI)
10	10.3 Bar (150 PSI)
15	15 Bar (218 PSI)
20	20 Bar (290 PSI)

Code	Seals
Omit	“D-Ring”

Kit	Part Number
D-Ring Seal	SK10-3S
Nitrile Seal	SK10-3S
Fluorocarbon Seal	SK10-3SV

General Description

Spool Type , Normally Open, Vent to Close Logic Element. For additional information see Technical Tips on pages LE2-LE7.

Features

- High flow capacity
- Used as high flow switching or metering element
- Can be used for inline pressure compensated flow control when used with restrictor (refer to application)
- More stable than poppet type
- Range of spring ratings available
- 1:1 pilot ratio
- Hardened working parts for maximum durability
- All external parts zinc plated

Performance Curve

Pressure Drop vs. Flow (Through cartridge only)

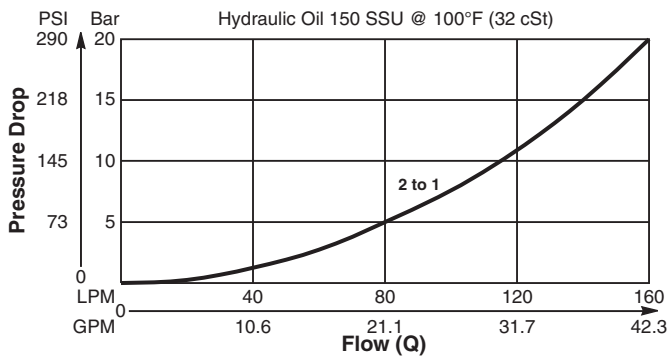

Specifications

Rated Flow	160 LPM (42 GPM)
Nominal Flow @ 7 Bar (100 PSI)	90 LPM (24 GPM)
Maximum Inlet Pressure	420 Bar (6000 PSI)
Leakage at 150 SSU (32 cSt)	125ml/min. @ 100 Bar (1450 PSI)
Switching Pressure	See ordering information
Cartridge Material	All parts steel. All operating parts hardened steel.
Operating Temp. Range/Seals	-34°C to +121°C (Nitrile) (-30°F to +250°F) -26°C to +204°C (Fluorocarbon) (-15°F to +400°F)
Fluid Compatibility/Viscosity	Mineral-based or synthetic with lubricating properties at viscosities of 45 to 2000 SSU (6 to 420 cSt)
Filtration	ISO-4406 18/16/13, SAE Class 4
Approx. Weight	0.37 kg (0.82 lbs.)
Cavity	C16-3S (See BC Section for more details)

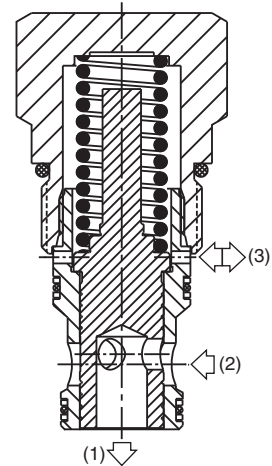
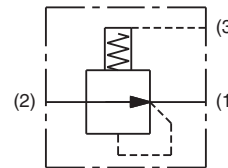

Dimensions

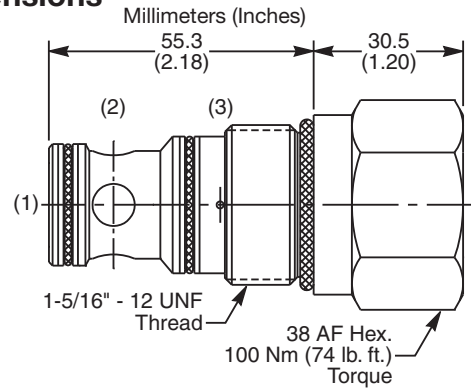

Ordering Information

R06H3 **N**

16 Size Logic Element Switching Pressure Seals

Code	Switching Pressure Non Adjustable Preset
10.0	10.0 Bar (145 PSI)
15.0	15.0 Bar (218 PSI)

Code	Seals
N	Nitrile

Kit	Part Number
Nitrile Seal	SK30508N-1
Fluorocarbon Seal	SK30508V-1

CV	Check Valves
SH	Shuttle Valves
LM	Load/Motor Controls
FC	Flow Controls
PC	Pressure Controls
LE	Logic Elements
DC	Directional Controls
SV	Solenoid Valves
PV	Proportional Valves
CE	Coils & Electronics
BC	Bodies & Cavities
TD	Technical Data

General Description

Spool Type, Normally Open, Vent to Close Logic Element. For additional information see Technical Tips on pages LE2-LE7.

Features

- High flow capacity
- Used as high flow switching or metering element
- Can be used as pressure regulator with mainstage controlled remotely by a pilot relief valve or a proportional valve
- Integral pilot flow filter
- Various bias spring pressures available
- 1:1 pilot pressure ratio
- Hardened working parts for maximum durability
- All external parts zinc plated
- “D”-Ring eliminates backup rings

Performance Curve

Pressure Drop, vs. Flow (Through cartridge only)
 Hydraulic Oil 150 SSU @ 100F (32cSt)

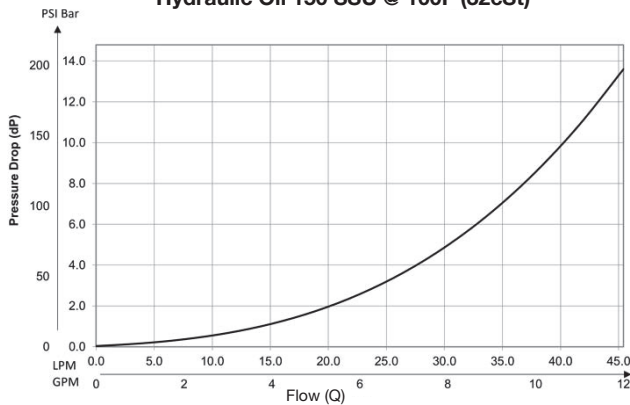

Specifications

Rated Flow	57 LPM (15 GPM)
Maximum Inlet Pressure	350 Bar (5000 PSI)
Leakage at 150 SSU (32 cSt)	82 ml/min. @207 Bar (3000 PSI)
Cartridge Material	All parts steel. All operating parts hardened steel.
Operating Temp. Range/Seals	-37°C to +93°C (“D”-Ring) (-35°F to +200°F) -34°C to +121°C (Nitrile) (-30°F to +250°F) -26°C to +204°C (Fluorocarbon) (-15°F to +400°F)
Fluid Compatibility/Viscosity	Mineral-based or synthetic with lubricating properties at viscosities of 45 to 2000 SSU (6 to 420 cSt)
Filtration	ISO-4406 18/16/13, SAE Class 4
Approx. Weight	0.14 kg (0.3 lbs.)
Cavity	C10-3S (See BC Section for more details)

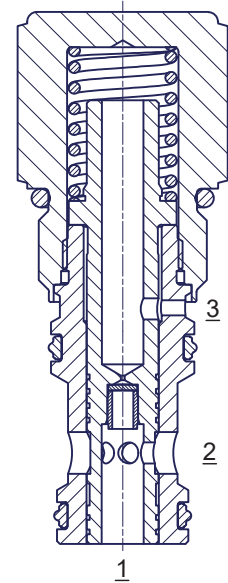
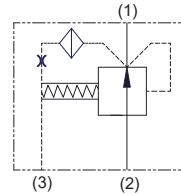

Dimensions Millimeters (Inches)

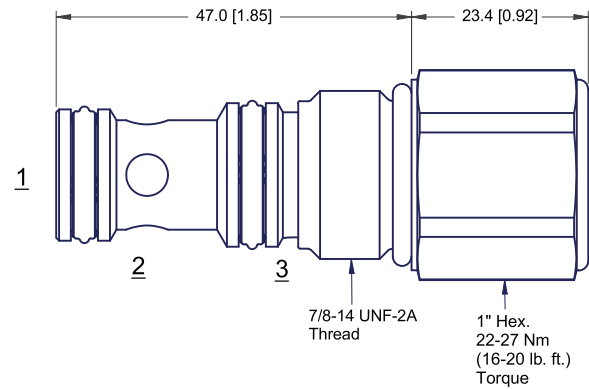

Ordering Information



LE103B Bias Spring
 10 Size Logic Element

Highlighted represents preferred options that offer the shortest lead times. Other options may be available, but at extended lead times.

Code	Bias Spring
01	1.7 Bar (25 PSI)
05	3.5 Bar (50 PSI)
07	6.9 Bar (100 PSI)
10	10.3 Bar (150 PSI)
15	15 Bar (218 PSI)
20	20 Bar (290 PSI)

Code	Seals
Omit	“D-Ring”

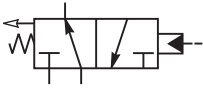
Kit	Part Number
D-Ring Seal	SK10-3S
Nitrile Seal	SK10-3S
Fluorocarbon Seal	SK10-3SV

	SERIES	CAVITY	DESCRIPTION	FLOW LPM/GPM	PRESSURE BAR/PSI	PAGE NO.
	DH103	C10-4	3 Way, External Pilot, Normally Open, Vent to Atmosphere.....	38/10	240/3500	DC2-DC3
	N5A125	5A.....	3 Way, 2 Position, External Drain, Open Transition.....	160/42	420/6000	DC4
	N5A300	100-1	3 Way, 2 Position, External Drain, Open Transition.....	400/105	420/6000	DC5

CV

Check
Valves

SH

Shuttle
Valves

LM

Load/Motor
Controls

FC

Flow
Controls

PC

Pressure
Controls

LE

Logic
Elements

DC

Directional
Controls

SV

Solenoid
Valves

PV

Proportional
Valves

CE

Coils &
Electronics

BC

Bodies &
Cavities

TD

Technical
Data

General Description

3-Way Pilot Operated Spool Valve. The DH103A/B/C Series Valves are used in normally closed or normally open directional control three way circuits requiring remote pilot actuation. The DH103 Series Valves are used to direct flow alternately from either side of a closed loop transmission for cooling or filtering. All external parts are zinc plated.

Operation (pressure at port 4 additive to spring)

DH103A (Normally Open)

- Neutral (Deactivated)
 Port (3) open to port (2), port (4) is blocked.
 - Activated with pilot pressure at port (1):
 Port (3) open to port (4), port (2) blocked.
- Note: There is an air breather vent plug in the end cap to allow for air pressure equalization in the spring chamber

DH103B (Normally Closed)

- Neutral (Deactivated)
 Port (4) open to port (3), port (2) is blocked.
- Activated with pilot pressure at port (1):
 Port (3) open to port (2), port (4) blocked.

DH103C (Normally Open)

- Neutral (Deactivated)
 Port (3) open to port (2), port (4) is blocked.
- Activated with pilot pressure at port (1):
 Port (3) open to port (4), port (2) blocked.

Specifications

Rated Flow	38 LPM (10 GPM)
Maximum Inlet Pressure	345 Bar (5000 PSI)
Leakage at 150 SSU (32 cSt)	50cc/min. @ 240 Bar (3500 PSI)
Cartridge Material	All parts steel. All operating parts hardened steel.
Operating Temp. Range/Seals	-37°C to +93°C ("D"-Ring) (-35°F to +200°F) -34°C to +121°C (Nitrile) (-30°F to +250°F) -26°C to +204°C (Fluorocarbon) (-15°F to +400°F)
Fluid Compatibility/ Viscosity	Mineral-based or synthetic with lubricating properties at viscosities of 45 to 2000 SSU (6 to 420 cSt)
Filtration	ISO-4406 18/16/13, SAE Class 4
Approx. Weight	0.17 kg (0.37 lbs.)
Cavity	C10-4 (See BC Section for more details)

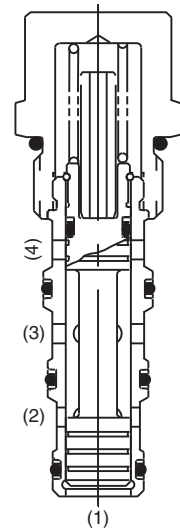
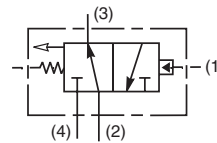
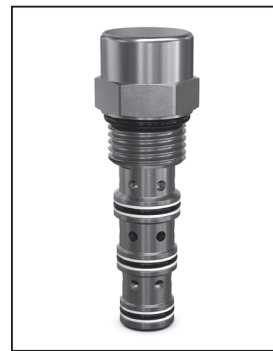

"A" SPOOL — DH103A

"B" SPOOL — DH103B

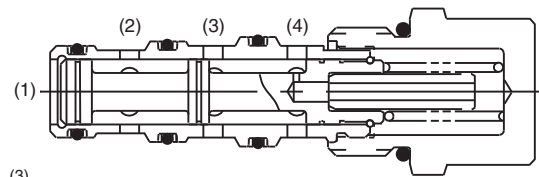
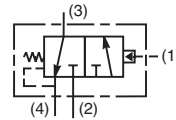

"C" SPOOL — DH103C

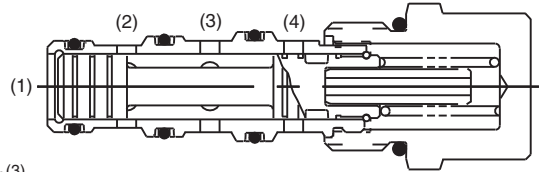
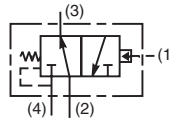

CV	Check Valves
SH	Shuttle Valves
LM	Load/Motor Controls
FC	Flow Controls
PC	Pressure Controls
LE	Logic Elements
DC	Directional Controls
SV	Solenoid Valves
PV	Proportional Valves
CE	Coils & Electronics
BC	Bodies & Cavities
TD	Technical Data

Performance Curve

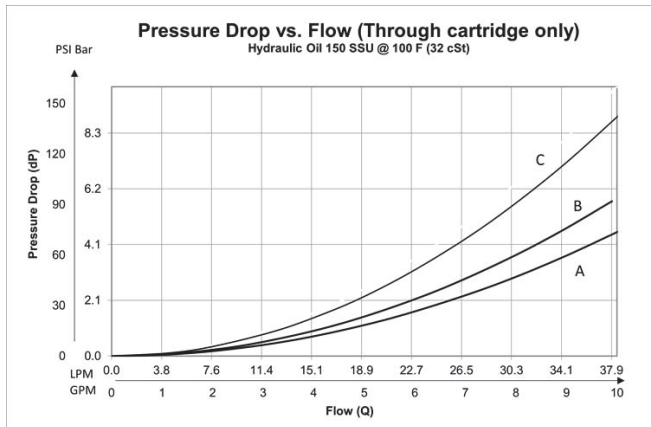

FLOW DIRECTION	SPOOL NO.		
	A	B	C
SPOOL SHIFTED	3 → 4 c	2 → 3 d	3 → 4 c
SPOOL NEUTRAL	2 → 3 a	3 → 4 b	2 → 3 a

Dimensions Millimeters (Inches)

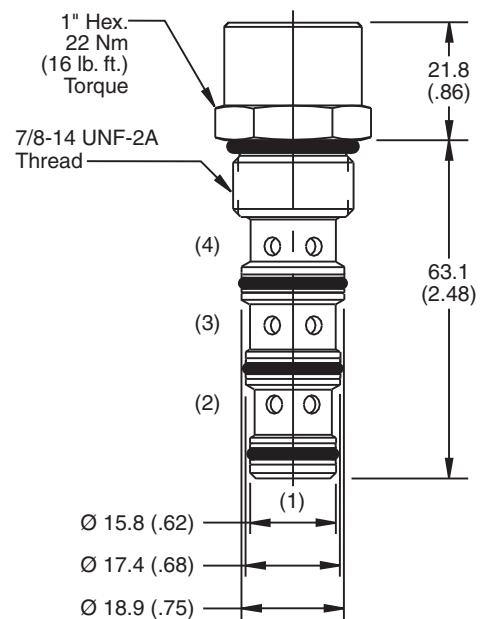

Ordering Information

DH103		
10 Size Pilot Operated Spool Valve	Spool Type	Shifting Pressure

Highlighted represents preferred options that offer the shortest lead times. Other options may be available, but at extended lead times.

Code / Spool Type	Diagram
A Normally open 2 position, vent to atmosphere.	
B Normally closed 2 position, internally drain.	
C Normally open, 2 position, internally drain.	

Code	Cracking Pressure
Omit	5.5 Bar (80 PSI)
16	11 Bar (160 PSI)

Code	Seals
Omit	Nitrile

Kit	Part Number
Nitrile Seal	SK10-4
Fluorocarbon Seal	SK10-4V

Order Bodies Separately
 See section BC

B10	—	4	—	8T
10 size		4-Way Cavity		Port Size

Code	Porting / Body Material
8T	SAE-8 / Steel (5000 PSI)

CV
Check Valves
SH
Shuttle Valves
LM
Load/Motor Controls
FC
Flow Controls
PC
Pressure Controls
LE
Logic Elements
DC
Directional Controls
SV
Solenoid Valves
PV
Proportional Valves
CE
Coils & Electronics
BC
Bodies & Cavities
TD
Technical Data

General Description

Pilot Operated Directional Valve, 3-Way, 2 Position, External Drain, Open Transition.

Features

- High flow capacity
- Used as high flow switching or metering element
- Range of spring settings available
- All external parts zinc plated

Performance Curve

Pressure Drop vs. Flow (Through cartridge only)

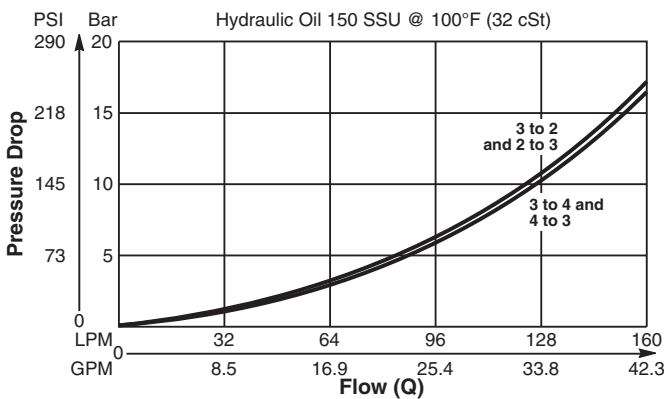

Specifications

Rated Flow	160 LPM (42 GPM)
Nominal Flow @ 7 Bar (100 PSI)	90 LPM (24 GPM)
Maximum Inlet Pressure	420 Bar (6000 PSI)
Pilot Switching Pressure	See ordering information
Cartridge Material	All parts steel. All operating parts hardened steel.
Operating Temp. Range/Seals	-34°C to +121°C (Nitrile) (-30°F to +250°F) -26°C to +204°C (Fluorocarbon) (-15°F to +400°F)
Fluid Compatibility/Viscosity	Mineral-based or synthetic with lubricating properties at viscosities of 45 to 2000 SSU (6 to 420 cSt)
Filtration	ISO-4406 18/16/13, SAE Class 4
Approx. Weight	0.33 kg (0.76 lbs.)
Cavity	5A (See BC Section for more details)

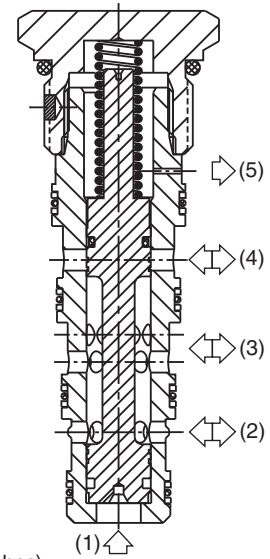
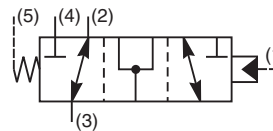
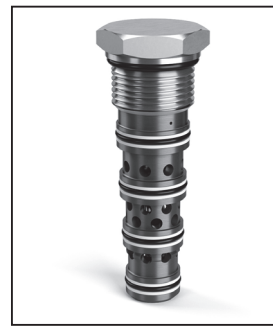

Dimensions

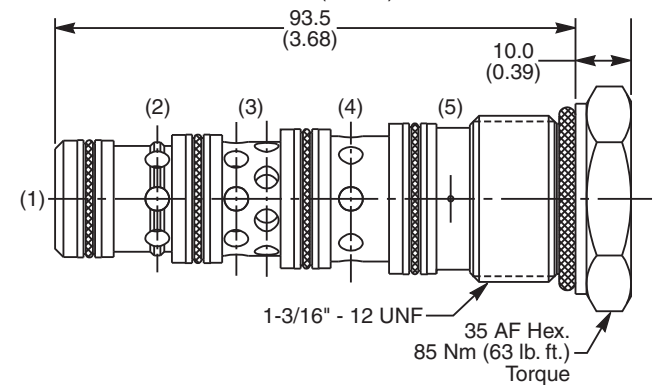

Ordering Information

N5A125 — **N**

Directional Valve (All Ports Open) Pilot Switching Pressure Seals

Highlighted represents preferred options that offer the shortest lead times. Other options may be available, but at extended lead times.

Code	Switching Pressure
6.9	6.9 Bar (100 PSI) Std.
10.0	10.0 Bar (145 PSI)

Code	Seals
N	Nitrile

Order Bodies Separately
 See section BC

LB10 **321** **S**

Line Body Porting Body Material

Code	Porting
321	3/4" SAE (main) 1/4" SAE (aux)

Code	Body Material
S	Steel (5000 PSI)

Kit	Part Number
Nitrile Seal	SK30103N-1
Fluorocarbon Seal	SK30103V-1

CV Check Valves

SH Shuttle Valves

LM Load/Motor Controls

FC Flow Controls

PC Pressure Controls

LE Logic Elements

DC Directional Controls

SV Solenoid Valves

PV Proportional Valves

CE Coils & Electronics

BC Bodies & Cavities

TD Technical Data

General Description

Pilot Operated Directional Valve, 3-Way, 2 Position, External Drain, Open Transition.

Features

- High flow capacity
- Used as high flow switching or metering element
- Range of spring settings available
- All external parts zinc plated

Performance Curve

Pressure Drop vs. Flow (Through cartridge only)

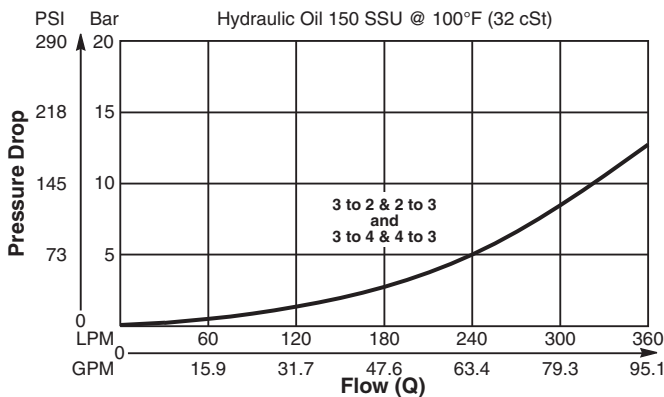

Specifications

Rated Flow	400 LPM (105 GPM)
Nominal Flow @ 7 Bar (100 PSI)	270 LPM (71 GPM)
Maximum Inlet Pressure	420 Bar (6000 PSI)
Pilot Switching Pressure	See ordering information
Cartridge Material	Steel operating parts hardened steel spool.
Operating Temp. Range/Seals	-34°C to +121°C (Nitrile) (-30°F to +250°F) -26°C to +204°C (Fluorocarbon) (-15°F to +400°F)
Fluid Compatibility/Viscosity	Mineral-based or synthetic with lubricating properties at viscosities of 45 to 2000 SSU (6 to 420 cSt)
Filtration	ISO-4406 18/16/13, SAE Class 4
Approx. Weight	1.00 kg (2.2 lbs.)
Cavity	100-1 (See BC Section for more details)

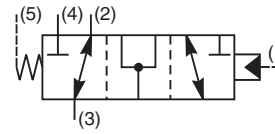
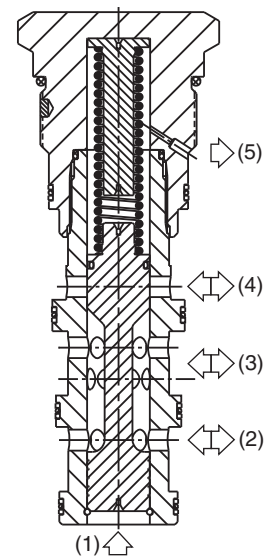

Dimensions Millimeters (Inches)

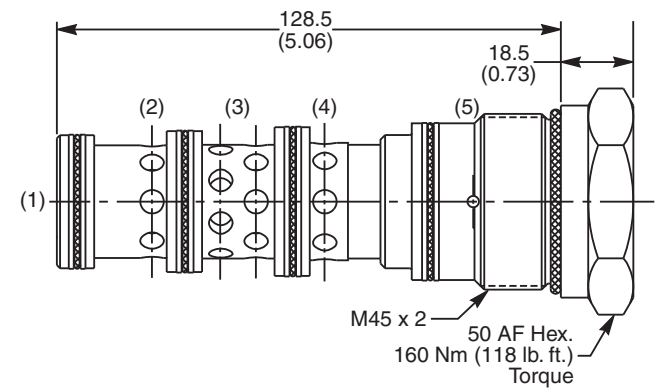

Ordering Information

N5A300 — **N**

Directional Valve (All Ports Open) Pilot Switching Pressure Seals

Highlighted represents preferred options that offer the shortest lead times. Other options may be available, but at extended lead times.

Code	Switching Pressure
6.9	6.9 Bar (100 PSI) Std.
10.0	10.0 Bar (145 PSI)

Code	Seals
N	Nitrile

Kit	Part Number
Nitrile Seal	SK30065N-1
Fluorocarbon Seal	SK30065V-1

Order Bodies Separately See section BC

LB10 **317** **S**







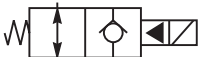

Line Body Porting Body Material

Code	Porting
317	1-1/4" SAE (main) 3/8" SAE (aux)

Code	Body Material
S	Steel (5000 PSI)

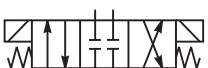
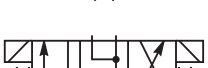
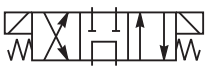

CV	Check Valves
SH	Shuttle Valves
LM	Load/Motor Controls
FC	Flow Controls
PC	Pressure Controls
LE	Logic Elements
DC	Directional Controls
SV	Solenoid Valves
PV	Proportional Valves
CE	Coils & Electronics
BC	Bodies & Cavities
TD	Technical Data

	SERIES	CAVITY	DESCRIPTION	FLOW LPM/GPM	PRESSURE BAR/PSI	PAGE NO.
	Technical Tips.....					SV2-SV6
2 WAY POPPET TYPE						
	DSH081	C08-2	2 Position, 2 Way, N.C. or N.O.	30/8	350/5000	SV7-SV8
	DSH101	C10-2	2 Position, 2 Way, N.C. or N.O.	60/15	350/5000	SV9-SV10
	DSH121	C12-2	2 Position, 2 Way, N.C. or N.O.	90/24	350/5000	SV11-SV12
	DSH161	C16-2	2 Position, 2 Way, N.C. or N.O.	150/40	350/5000	SV13-SV14
	DSL201	C20-2	2 Position, 2 Way, N.C. or N.O.	260/70	250/3600	SV15-SV16
Bi-Directional Poppet, N.C or N.O.						
	DSL087 (NEW)	C08-2	Bi-Directional Poppet, N.C or N.O.	1.1/3	250/3600	SV17-SV18
	GS02 81	C08-2	Bi-Directional Poppet, N.C	34/9	350/5000	SV19-SV20
	GS04 81	2R	Bi-Directional Poppet, N.C	68/18	350/5000	SV21-SV22
	GS06 81	C16-2	Bi-Directional Poppet, N.C	285/75	350/5000	SV23-SV24
	GS02 86	C08-2	Bi-Directional Poppet, N.O	34/9	350/5000	SV25-SV26
	GS04 86	2R	Bi-Directional Poppet, N.O	68/18	350/5000	SV27-SV28
	GS06 86	C16-2	Bi-Directional Poppet, N.O	285/75	350/5000	SV29-SV30
2 WAY SPOOL TYPE						
	DSH082	C08-2	2 Position, 2 Way	15/4	350/5000	SV31-SV32
	DSH102	C10-2	2 Position, 2 Way	30/8	350/5000	SV33-SV34
3 WAY SPOOL TYPE						
	DSH083	C08-3	2 Position, 3 Way	15/4	350/5000	SV35-SV37
	DSH103	C10-3	2 Position, 3 Way	30/8	350/5000	SV38-SV40
4 WAY, 2 POSITION SPOOL TYPE						
	DSH084	C08-4	2 Position, 4 Way	15/4	350/5000	SV41-SV42
	DSH104	C10-4	2 Position, 4 Way	38/10	350/5000	SV43-SV44
	DSH164	C16-4	2 Position, 4 Way	113/30	350/5000	SV45-SV46
4 WAY, 3 POSITION SPOOL TYPE						
	GS02 51	C08-4	3 Position, 4 Way	17/4.5	350/5000	SV47-SV48
	GS02 53	C08-4	3 Position, 4 Way	15/4	350/5000	SV49-SV50
	GS02 57	C08-4	3 Position, 4 Way	13/3.5	350/5000	SV51-SV52
	GS02 59	C08-4	3 Position, 4 Way	13/3.5	350/5000	SV53-SV54
	DSL105	C10-4	3 Position, 4 Way	26/7	250/3600	SV55-SV56
	GS04 52D	C10-4	3 Position, 4 Way	42/11	350/5000	SV57-SV58
	GS04 54D	C10-4	3 Position, 4 Way	42/11	350/5000	SV59-SV60
	GS04 57D	C10-4	3 Position, 4 Way	42/11	350/5000	SV61-SV62
	GS04 59D	C10-4	3 Position, 4 Way	42/11	350/5000	SV63-SV64

CV
Check Valves

SH
Shuttle Valves

LM
Load/Motor Controls

FC
Flow Controls

PC
Pressure Controls

LE
Logic Elements

DC
Directional Controls

SV
Solenoid Valves

PV
Proportional Valves

CE
Coils & Electronics

BC
Bodies & Cavities

TD
Technical Data

Technical Tips

COMMON OPTIONS

As you will see, Parker offers a variety of solenoid valve products. As such, some of the options mentioned below may not be available on all valves. Consult the model coding and dimensions for each valve for more specifics. Here are some of the common options available.

Seals: Valves feature a Polyurethane “D”-Ring. The “D”-Ring eliminates the need for backup rings. For more information on the “D”-Ring see the Technical Data section of the catalog. The majority of the products are also available in Nitrile or Fluorocarbon seals. Contact factory for availability. You should always match the seal compatibility to the temperature and fluid being used in your application.

Coils: Coils can be ordered as part of the full assembly or separately. Various terminations and voltages are available. For detailed information on the coil options consult the coil section of the catalog. The ordering information for each valve will direct you to the proper coil.

Manual Overrides: Many of our solenoid valves are also offered with a manual override. The override allows the user to shift the valve when coil force is not available. They provide a means of shifting the solenoid valve due to a loss of power or a coil failure. Overrides are intended for infrequent usage and are not designed to be used as a primary method of valve actuation.

The most common override option for the 2 Position valves is the push & twist style shown below. With a normally closed valve or a pull style tube, the valve is in normal operation (or de-energized)

when the pin is seated in the slotted groove at the lowest position. To shift the valve manually, the operator pushes down on the knob and twists it counterclockwise. When the pressure is removed from the knob, an internal spring pushes the pin up the slotted groove to the upper position of the override. With a normally open valve, or push style tube, the actuation is reversed. The valve is in the normal position (or de-energized)

when the pin is in the upper position of the override. To shift the valve manually, the operator pushes

down on the knob and twists it clockwise. Once the pin is seated in the slotted groove, the operator can remove pressure and the valve will stay actuated.

Solenoid Valves

3 Position valves are offered with a Push / Pull style override. This override is not detented. Springs hold the spool of the valve in the center position of the valve. When the knob is pulled, the spool is moved upward simulating the action of the upper coil. When the override is pushed, the spool moves downward simulating the action of the lower coil. When no pressure is applied to the knob, it centers the spool.

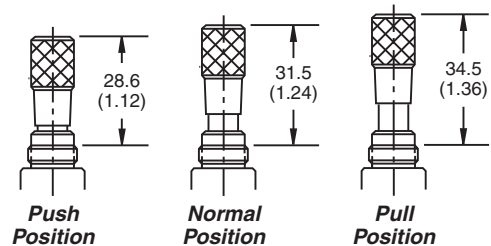

Screens: 2 way valves can be ordered with a small mesh screen (60 x 60 mesh) placed over the cage of the cartridge valve. This screen is intended for cursory protection of the internal components of the solenoid valve. It should not be used as the primary method of filtration. The mesh catches small pieces of debris that could impede spool or poppet movement. Note that a screen will trap debris from both directions. Thus, any debris coming from the nose of the cartridge would be trapped inside the valve. As such, we recommend that screens be implemented in only applications where hydraulic fluid passes through the cartridge from the side of the cage to the nose. It should also be noted that the pressure drop through the cartridge will be increased slightly due to the small restriction of the mesh. As the screen fills with debris, pressure drop will continue to rise.

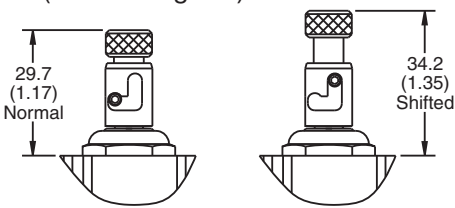

Normally Closed Pull Type Tube

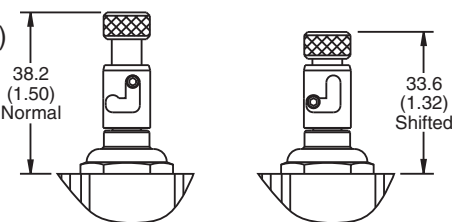

Normally Open Push Type Tube

CV
Check Valves
SH
Shuttle Valves
LM
Load/Motor Controls
FC
Flow Controls
PC
Pressure Controls
LE
Logic Elements
DC
Directional Controls
SV
Solenoid Valves
PV
Proportional Valves
CE
Coils & Electronics
BC
Bodies & Cavities
TD
Technical Data

PRODUCT TYPES / APPLICATIONS

Two Way Poppet Valves

Two way poppet valves are pilot operated, low leakage solenoid actuated valves. Two way poppet valves control the flow of a two way function by blocking flow in one direction (similar to a check valve). They are generally selected due to their low leakage and ability to meet higher flow requirements. Poppet valves are often used on single operation actuators or in unloading functions. They are available in normally closed and normally open types. In addition, free reverse flow and fast response versions are available.

Normally Closed Poppet

Normally closed two way poppet valves act as a check valve when de-energized, blocking flow from one direction and allowing restricted free flow in the reverse condition. When energized, the poppet lifts allowing free flow from the side to the nose of the cartridge. Should the application require free flow in both directions, the free reverse flow option should be chosen.

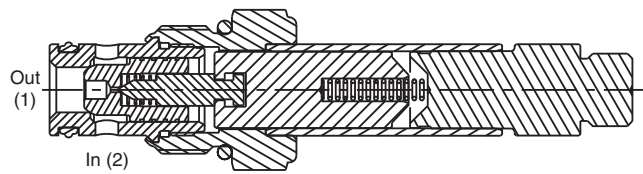
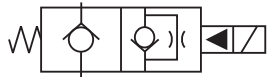

OPERATION - The valve pilot is held on its seat by spring force, blocking pilot flow. This allows pressure at the inlet (port 2) to hold the poppet on its seat, thus, preventing flow through the valve (2-1). If the nose of the cartridge (port 1) is pressurized, the pressure will overcome the spring force, pushing the poppet off of its seat, allowing free flow through the cartridge (1-2). When the coil is energized, the valve pilot is pulled off of its seat. This vents the pressure inside the poppet to port 1, creating a pressure imbalance across the main poppet. This differential lifts the poppet allowing flow from the side to nose (2-1). Since poppet valves are piloted operated, a minimum amount of pressure differential (25-50 psi) and flow between ports 2 and 1 must be present to overcome the spring and lift the poppet.

Normally Open Poppet

Normally open two way poppet valves, when de-energized, allow free flow from the side (port 2) of the cartridge to the nose (port 1). Flow in the reverse direction is restricted. Should free flow be required in both directions, the free reverse flow option should be specified. Once the coil is energized the normally open poppet valve acts as a check valve, blocking flow from one direction and allowing restricted free flow in the reverse condition.

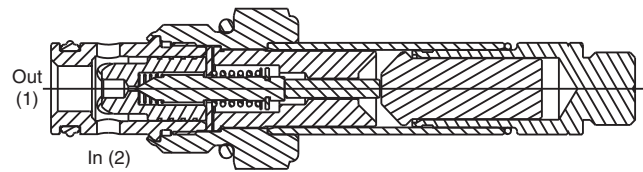
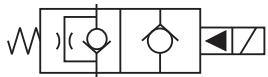

OPERATION - The valve pilot is held off its seat by spring force. Pilot flow is vented to port 1, creating a pressure imbalance that moves the main poppet. This differential lifts the poppet allowing flow from the side to nose (2-1). Since poppet valves are piloted operated, a minimum amount of pressure differential (25-50 psi) between ports 2 and 1 must be present to overcome the spring and lift the poppet. When the coil is energized, the coil force overcomes the spring force to drive the valve pilot and main poppet into their seats, thus blocking flow from port 2-1. If the nose of the cartridge (port 1) is pressurized, the pressure will overcome the spring force and solenoid force, pushing the poppet off of its seat, allowing restricted flow through the cartridge (1-2).

CV
Check Valves

SH
Shuttle Valves

LM
Load/Motor Controls

FC
Flow Controls

PC
Pressure Controls

LE
Logic Elements

DC
Directional Controls

SV
Solenoid Valves

PV
Proportional Valves

CE
Coils & Electronics

BC
Bodies & Cavities

TD
Technical Data

Free Reverse Flow

The free reverse flow versions are available on both the normally closed and normally open poppet valves. As mentioned above, the operation is the same as the standard poppet valve except flow through the reverse direction is not restricted. The free reverse flow option is only needed if the application requires flow to pass through the cartridge valve from the nose to side (port 1 to port 2).

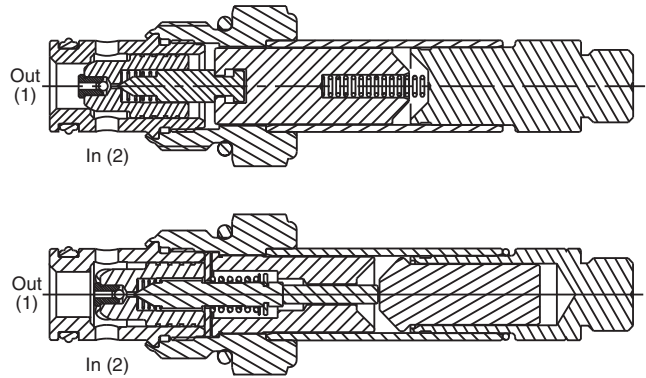
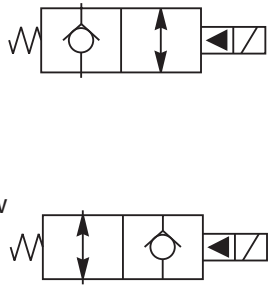

Fast Response

Since poppet valves are pilot operated valves, a few milliseconds are needed to move the pilot and allow the poppet to lift. Should a faster response time be required on normally closed poppet valves, this option can be chosen. The fast response is accomplished by reducing the movement of the pilot. Thus, the flow capacity of the poppet valve is also decreased.

Two Way Spool Valves

Two way spool valves are direct acting, fast responding solenoid actuated valves. Like the poppet valves described earlier, they block the flow of a two way function. Unlike two way poppet valves, spool valves block flow from both the side port and the nose port. They do not have the check like function of the poppet valve, thus they are either open or closed. Spool valves are directed operated, so they respond more quickly to coil voltage than poppet valves. Spool valves operate via a sliding spool, thus, some leakage will be present due to the required spool clearance. Spool valves block flow in both directions, but the preferred flow path is still from the side of the cartridge to the nose due to the flow forces acting on the spool. Two way spool valves are available in normally open and normally closed types.

Normally Closed Spool

When de-energized, the spool is positioned by the spring force to cover both the side (2) and nose (1) ports of the valve. Thus, no flow is allowed from either direction. Once the coil is energized, the spool shifts exposing a flow path between the two ports. Flow can then be passed through the valve from either direction.

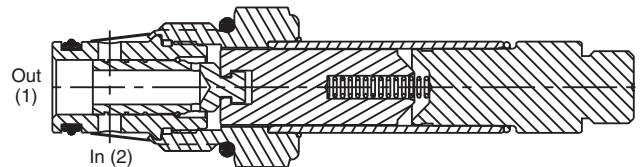

Normally Open Spool

When de-energized, the spool is positioned by the spring force so that a flow path between the side (2) and nose (1) ports is exposed, allowing flow through the valve from either direction. Once the coil is energized, the spool shifts to cover both the side (2) and nose (1) ports of the valve. Thus, no flow is allowed from either direction.

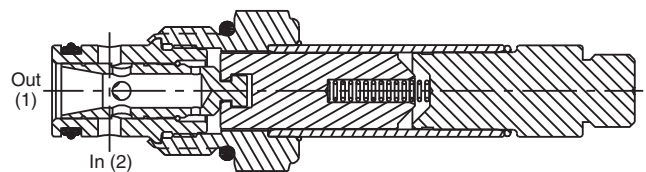
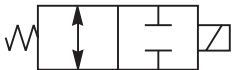

CV
Check Valves
SH
Shuttle Valves
LM
Load/Motor Controls
FC
Flow Controls
PC
Pressure Controls
LE
Logic Elements
DC
Directional Controls
SV
Solenoid Valves
PV
Proportional Valves
CE
Coils & Electronics
BC
Bodies & Cavities
TD
Technical Data

Bi-Directional Poppet Valve

Bi-directional poppet valves combine the dual blocking function of spool valves with the lower leakage capabilities of poppet valves. These valves also have a limited flow capacity compared to standard poppet or spool valves.

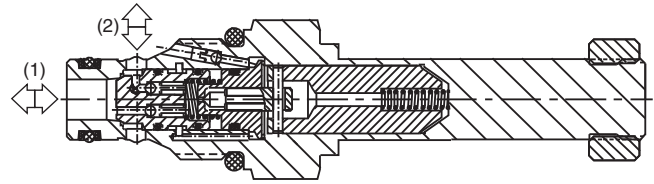
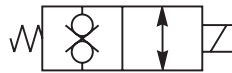

Two Position, Three Way Spool Valve

Three way spool solenoid valves provide directional control of flow. Each three way valve has a special internal spool which connects two of the three valve ports. When actuated, the spool connects a different combination of valve ports. These valves are often used for raise and lower functions of a single acting cylinder, control of a uni-directional motor, or as a circuit selector.

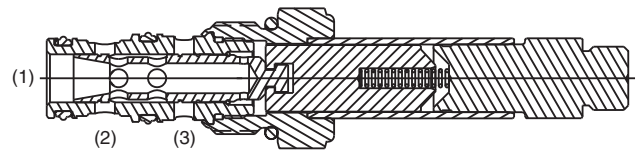
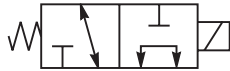

OPERATION - In the de-energized mode, the spool is positioned by spring force. When energized, the coil force directly shifts the spool against the spring, thus changing the flow through the valve. Each spool type can be used as a normally open, normally closed, or selector valve. To explain this we will review the DSL103A which is pictured here. When the valve is de-energized, ports 1 and 2 are open to one another. When energized, ports 1 and 3 are connected.

Thus, if we use port 3 as our pressure port, we have a

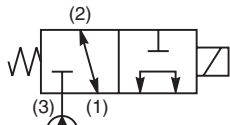

normally closed valve. The pressure port (3) is blocked, while the actuator port (1) is drained to tank (2).

If we use port 2 as our pressure port, we have a

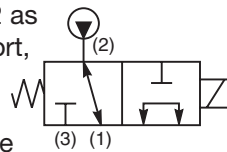

normally open valve. The pressure port (2) is connected to the actuator port (1), and the tank port (3) is blocked.

If we use port 1 as our pressure port, we have a

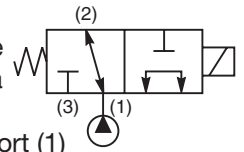

selector valve. The pressure port (1) is either connected to port (2) or port (3). Thus, it is "selecting" which port will get the system pressure and flow.

Note that in all three examples, we were using the same valve. The flow forces acting on the spool change depending on which port is pressurized. Thus, if you will be shifting the three way valve under full flow and pressure, it is important to review the shift limit characteristics for the flow paths you have chosen to be sure the coil has enough force to shift the spool. Various spools are available in this catalog to maximize the flow and pressure capacities for the desired flow function.

CV
Check Valves
SH
Shuttle Valves
LM
Load/Motor Controls
FC
Flow Controls
PC
Pressure Controls
LE
Logic Elements
DC
Directional Controls
SV
Solenoid Valves
PV
Proportional Valves
CE
Coils & Electronics
BC
Bodies & Cavities
TD
Technical Data

**Two Position,
Four Way Spool Valve**

Four way spool solenoid valves provide directional control of flow. Each four way valve has a special internal spool which connects some combination of the four valve ports together. When actuated, the spool connects a different combination of valve ports. These valves are often used for the raise / lower function of a double acting cylinder, or as a forward / reverse function of bi-directional motors.

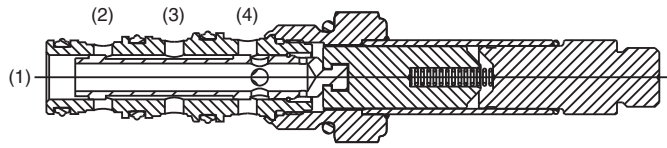
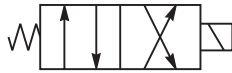

OPERATION - In the de-energized mode, the spool is positioned by spring force. When energized, the coil force directly shifts the spool against the spring, thus changing the flow through the valve. Each spool type is customized to provide the flow combination desired. The flow forces acting on the spool change depending on which port is pressurized. Thus, if you will be shifting the four way valve under full flow and pressure, it is important to review the shift limit characteristics for the flow paths you have chosen to ensure the coil has enough force to shift the spool. Various spools are shown in this catalog to maximize the flow and pressure capacities for the desired flow function.

**Three Position,
Four Way Spool Valve**

Three position, four way spool solenoid valves provide directional control of flow. Each four way valve has a special internal spool which connects some combination of the four ports together. When one coil is actuated, the spool connects a different combination of valve ports. When the other coil is actuated a third combination of valve ports are connected. These valves are often used for the raise / lower function of a double acting cylinder, or as a forward / reverse function of bi-directional motors. The center position can be used to stop the actuator in mid-stroke, or dump the pump flow.

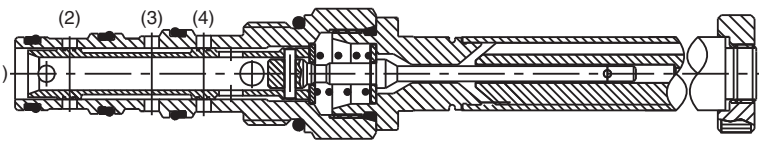

OPERATION - In the de-energized mode, the spool is positioned by spring force. When energized, the coil force directly shifts the spool against the spring, thus changing the flow through the valve. Each spool type is customized to provide the flow combination desired. The flow forces acting on the spool change depending on which port is pressurized. Thus, if you will be shifting the four way valve under full flow and pressure, it is important to review the shift limit characteristics for the flow paths you chosen to ensure the coil has enough force to shift the spool. Various spools are shown in this catalog to maximize the flow and pressure capacities for the desired flow function.

CV
Check Valves

SH
Shuttle Valves

LM
Load/Motor Controls

FC
Flow Controls

PC
Pressure Controls

LE
Logic Elements

DC
Directional Controls

SV
Solenoid Valves

PV
Proportional Valves

CE
Coils & Electronics

BC
Bodies & Cavities

TD
Technical Data

General Description

2-Way Poppet Valves.

For additional information see Technical Tips on pages SV2-SV6.

Features

- Replaceable, one piece encapsulated, coils with minimal amperage draw
- Variety of coil terminations and voltages
- Variety of manual override options available
- Polyurethane “D”-Ring eliminates need for backup rings
- Spherical poppet for low leakage
- Nylon inserted jam-nut provides secure holding in high vibration applications
- All external parts zinc plated

Specifications

Rated Flow	30 LPM (8 GPM)									
Maximum Inlet Pressure	350 Bar (5000 PSI)									
Leakage at 150 SSU (32 cSt)	5 drops/min. (.33 cc/min.)									
Minimum Operating Voltage	85% of rated voltage at 20°C (72°F).									
Response Time	<table border="1"> <tr> <td></td> <td>Energized</td> <td>De-Energized</td> </tr> <tr> <td>C, CR</td> <td>50 ms</td> <td>50 ms</td> </tr> <tr> <td>N, NR</td> <td>50 ms</td> <td>40 ms</td> </tr> </table>		Energized	De-Energized	C, CR	50 ms	50 ms	N, NR	50 ms	40 ms
	Energized	De-Energized								
C, CR	50 ms	50 ms								
N, NR	50 ms	40 ms								
Cartridge Material	All parts steel. All operating parts hardened steel.									
Operating Temp. Range/Seals	-37°C to +93°C (“D”-Ring) (-35°F to +200°F) -34°C to +121°C (Nitrile) (-30°F to +250°F) -26°C to +204°C (Fluorocarbon) (-15°F to +400°F)									
Fluid Compatibility/Viscosity	Mineral-based or synthetic with lubricating properties at viscosities of 45 to 2000 SSU (6 to 420 cSt)									
Filtration	ISO 4406 18/16/13, SAE Class 4									
Approx. Weight	.11 kg (.25 lbs.)									
Cavity	C08-2 (See BC Section for more details)									

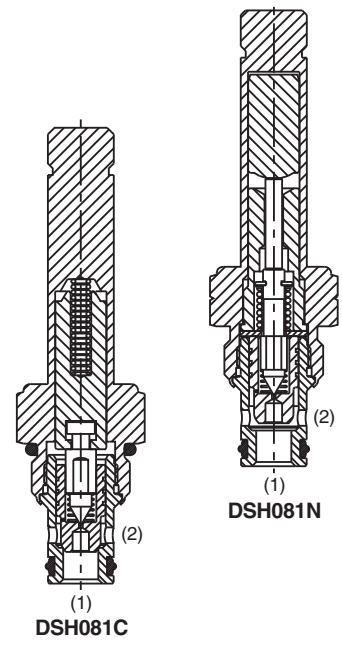
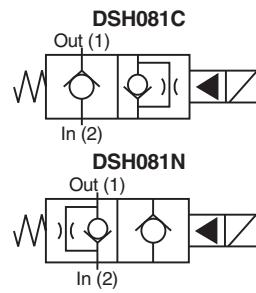

Performance Curves

Pressure Drop vs. Flow (Through cartridge only)

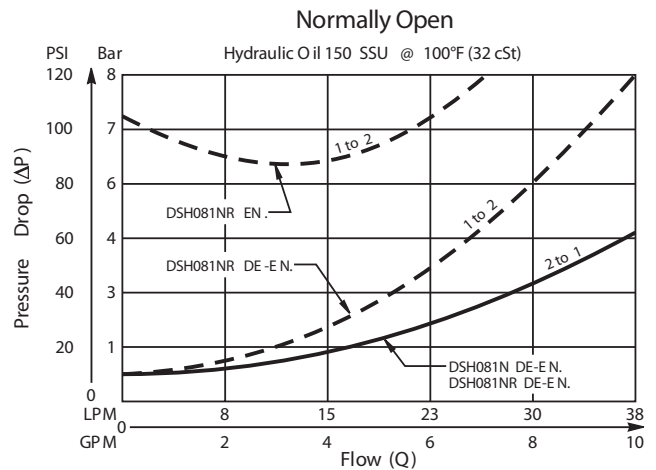
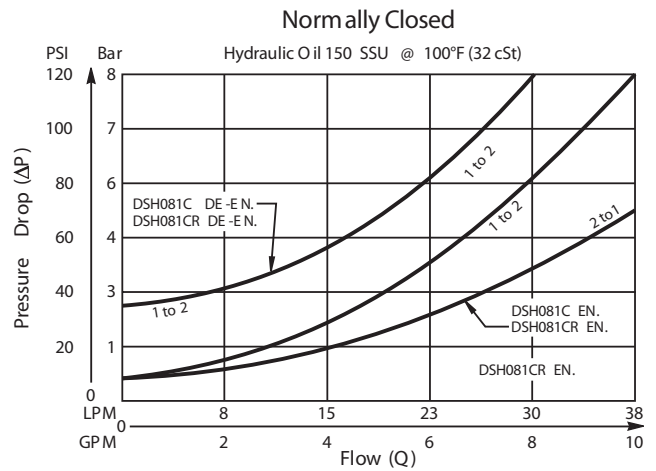

CV
Check Valves

SH
Shuttle Valves

LM
Load/Motor Controls

FC
Flow Controls

PC
Pressure Controls

LE
Logic Elements

DC
Directional Controls

SV
Solenoid Valves

PV
Proportional Valves

CE
Coils & Electronics

BC
Bodies & Cavities

TD
Technical Data

Dimensions Millimeters (Inches)

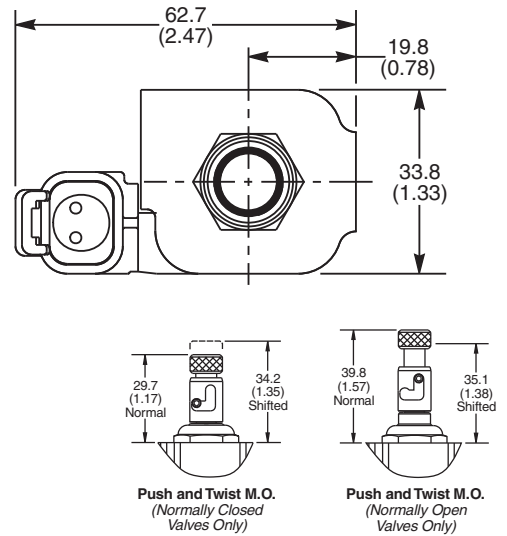
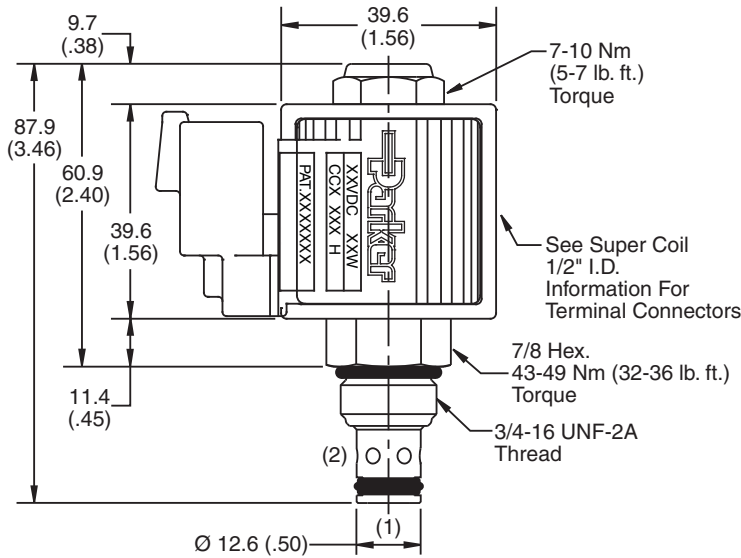

Ordering Information

DSH081

08 Size Solenoid Valve **Style** **Override Option**

Highlighted represents preferred options that offer the shortest lead times. Other options may be available, but at extended lead times.

Coil(s) sold separately. Please see section CE of this catalog, 1/2" Super-Coil (CC series), for ordering information.

Order Bodies Separately See section BC

Code / Style	
C Normally Closed Metered reverse flow	
CR Normally Closed Free reverse flow	
N Normally Open Metered reverse flow	
NR Normally Open Free reverse flow	

Code	Override Options
Omit	None
T	Push & Twist (N.C. & N.O.)

B08 — **2** — **6T**

08 size 2-Way Cavity Port Size

Code	Seals
Omit	"D"-Ring

Code	Port Size / Body Material
6T	SAE-6 / Steel (5000 PSI)

Kit	Part Number
D-Ring Seal	SK08-2
Nitrile Seal	SK08-2
Fluorocarbon Seal	SK08-2V

CV
Check Valves

SH
Shuttle Valves

LM
Load/Motor Controls

FC
Flow Controls

PC
Pressure Controls

LE
Logic Elements

DC
Directional Controls

SV
Solenoid Valves

PV
Proportional Valves

CE
Coils & Electronics

BC
Bodies & Cavities

TD
Technical Data

General Description

2-Way Poppet Valves.
 For additional information see Technical Tips on pages SV2-SV6.

Features

- Low hysteresis
- Replaceable, one piece encapsulated coils with minimal amperage draw
- Various coil terminations and voltages
- Various manual override options
- Polyurethane “D”-Ring eliminates need for backup rings
- Nylon inserted jam-nut provides secure holding in high vibration applications
- All external parts zinc plated

Specifications

Rated Flow	60 LPM (15 GPM)									
Maximum Inlet Pressure	350 Bar (5000 PSI)									
Leakage at 150 SSU (32 cSt)	5 drops/min. (.33 cc/min.)									
Minimum Operating Voltage	85% of rated voltage at 20°C (72°F).									
Response Time	<table border="1"> <tr> <td></td> <td>Energized</td> <td>De-Energized</td> </tr> <tr> <td>C, CR</td> <td>80 ms</td> <td>150 ms</td> </tr> <tr> <td>N, NR</td> <td>70 ms</td> <td>35 ms</td> </tr> </table>		Energized	De-Energized	C, CR	80 ms	150 ms	N, NR	70 ms	35 ms
	Energized	De-Energized								
C, CR	80 ms	150 ms								
N, NR	70 ms	35 ms								
Cartridge Material	All parts steel. All operating parts hardened steel.									
Operating Temp. Range/Seals	-37°C to +93°C (“D”-Ring) (-35°F to +200°F) -34°C to +121°C (Nitrile) (-30°F to +250°F) -26°C to +204°C (Fluorocarbon) (-15°F to +400°F)									
Fluid Compatibility/Viscosity	Mineral-based or synthetic with lubricating properties at viscosities of 45 to 2000 SSU (6 to 420 cSt)									
Filtration	ISO 4406 18/16/13, SAE Class 4									
Approx. Weight	.20 kg (0.41 lbs.)									
Cavity	C10-2 (See BC Section for more details)									

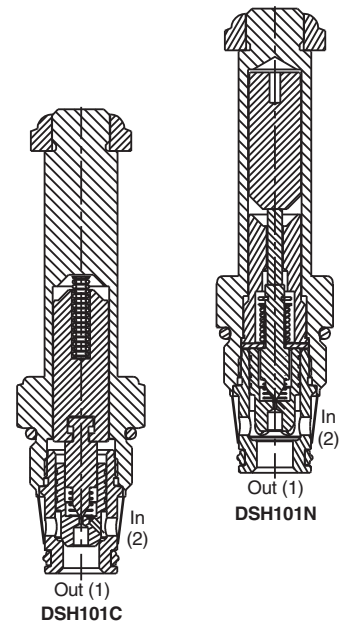
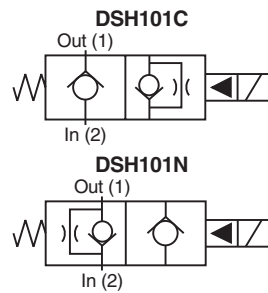
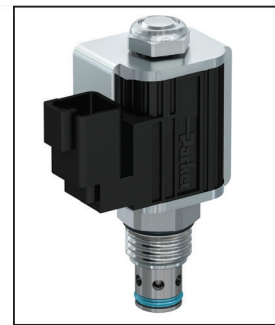

Performance Curves

Pressure Drop vs. Flow (Through cartridge only)

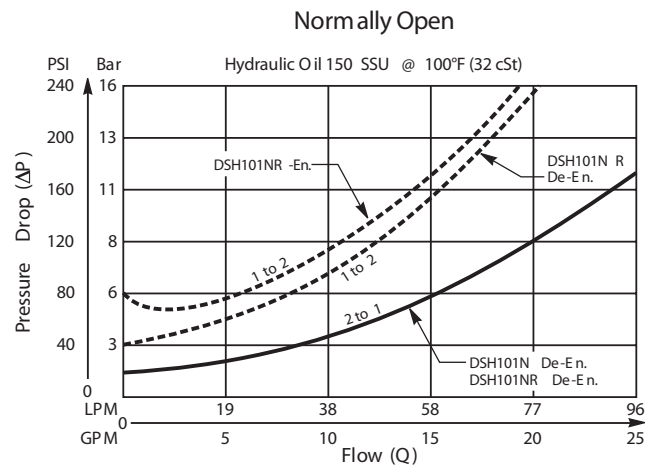
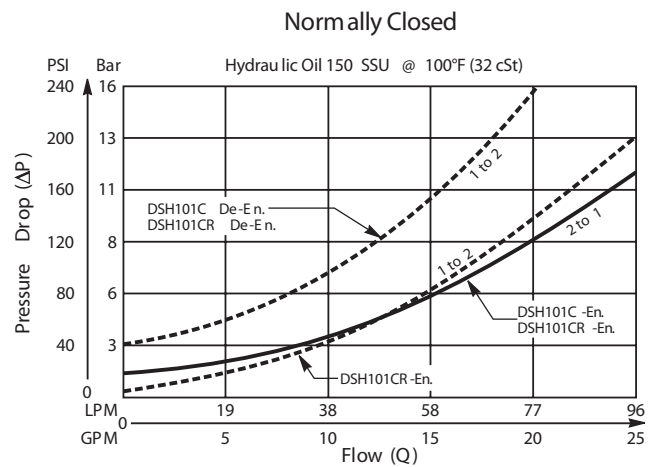

CV
Check Valves

SH
Shuttle Valves

LM
Load/Motor Controls

FC
Flow Controls

PC
Pressure Controls

LE
Logic Elements

DC
Directional Controls

SV
Solenoid Valves

PV
Proportional Valves

CE
Coils & Electronics

BC
Bodies & Cavities

TD
Technical Data

Dimensions Millimeters (Inches)

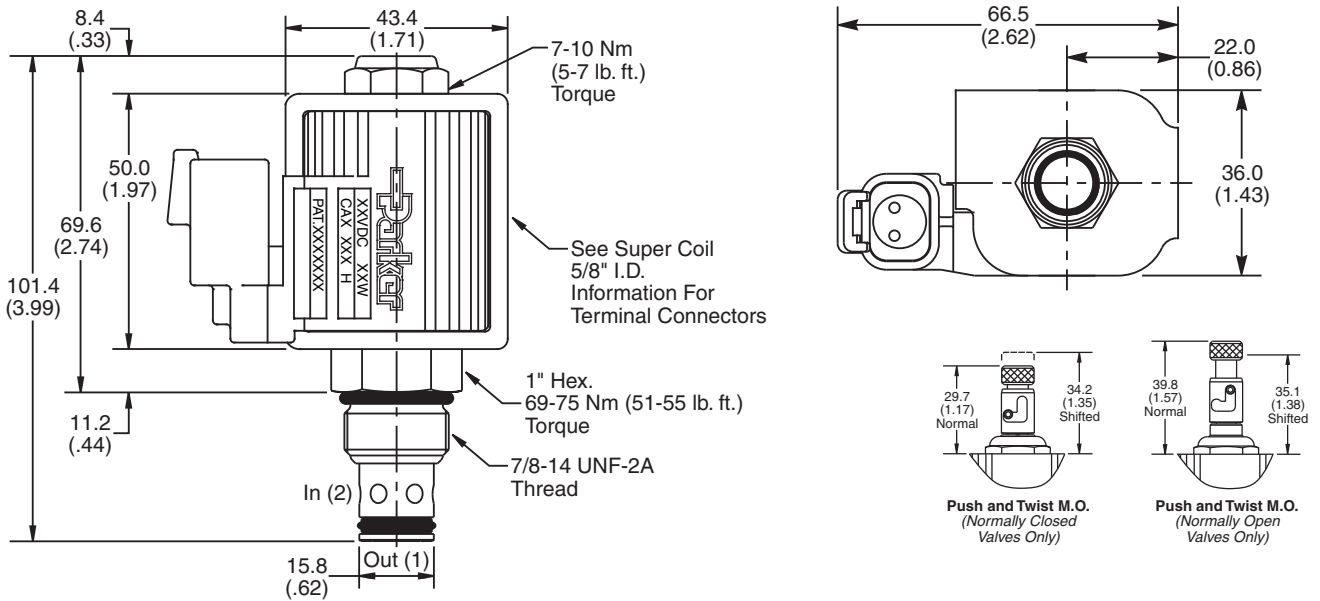

Ordering Information

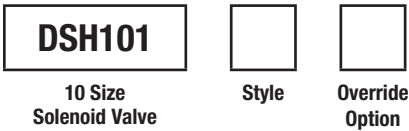

Highlighted represents preferred options that offer the shortest lead times. Other options may be available, but at extended lead times.

Coil(s) sold separately. Please see section CE of this catalog, 5/8" Super-Coil (CA series), for ordering information.

Order Bodies Separately
 See section BC

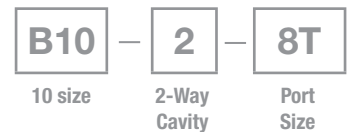

Code	Port Size / Body Material
8T	SAE-8 / Steel (5000 PSI)

Code / Style	Symbol
C Normally Closed Metered reverse flow	
CR Normally Closed Free reverse flow	
N Normally Open Metered reverse flow	
NR Normally Open Free reverse flow	

Code	Override Options
Omit	None
T	Push & Twist (N.C. & N.O.)

Code	Seals
Omit	"D"-Ring

Kit	Part Number
D-Ring Seal	SK10-2
Nitrile Seal	SK10-2
Fluorocarbon Seal	SK10-2V



General Description

2-Way Poppet Valves.
 For additional information see Technical Tips on pages SV2-SV6.

Features

- Low hysteresis
- Replaceable, one piece encapsulated coils with minimal amperage draw
- Various coil terminations and voltages
- Various manual override options
- All external parts zinc plated

Specifications

Rated Flow	90 LPM (24 GPM)									
Maximum Inlet Pressure	350 Bar (5000 PSI)									
Leakage at 150 SSU (32 cSt)	5 drops/min. (.33 cc/min.)									
Minimum Operating Voltage	85% of rated voltage at 20°C (72°F).									
Response Time	<table border="1"> <tr> <td></td> <td>Energized</td> <td>De-Energized</td> </tr> <tr> <td>C, CR</td> <td>100 ms</td> <td>150 ms</td> </tr> <tr> <td>N, NR</td> <td>70 ms</td> <td>150 ms</td> </tr> </table>		Energized	De-Energized	C, CR	100 ms	150 ms	N, NR	70 ms	150 ms
	Energized	De-Energized								
C, CR	100 ms	150 ms								
N, NR	70 ms	150 ms								
Cartridge Material	All parts steel. All operating parts hardened steel.									
Operating Temp. Range/Seals	-34°C to +121°C (Nitrile) (-30°F to +250°F) -26°C to +204°C (Fluorocarbon) (-15°F to +400°F)									
Fluid Compatibility/Viscosity	Mineral-based or synthetic with lubricating properties at viscosities of 45 to 2000 SSU (6 to 420 cSt)									
Filtration	ISO 4406 18/16/13, SAE Class 4									
Approx. Weight	.29 kg (.65 lbs.)									
Cavity	C12-2 (See BC Section for more details)									

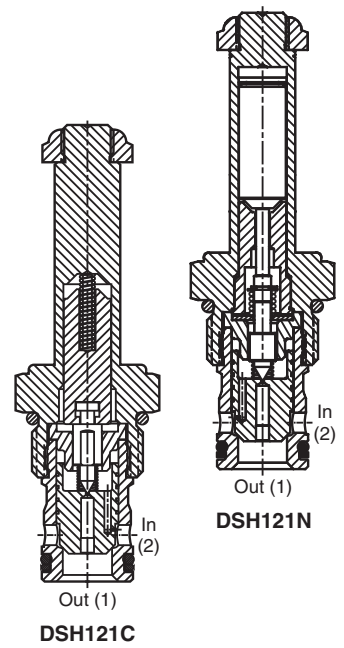
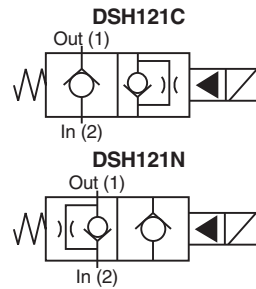

Performance Curves

Pressure Drop vs. Flow (Through cartridge only)

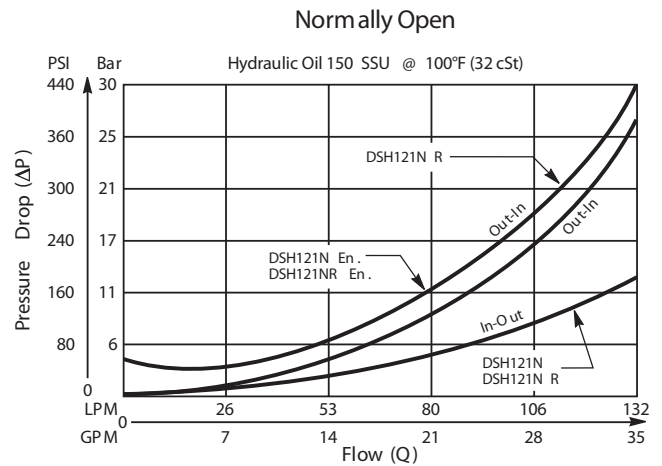
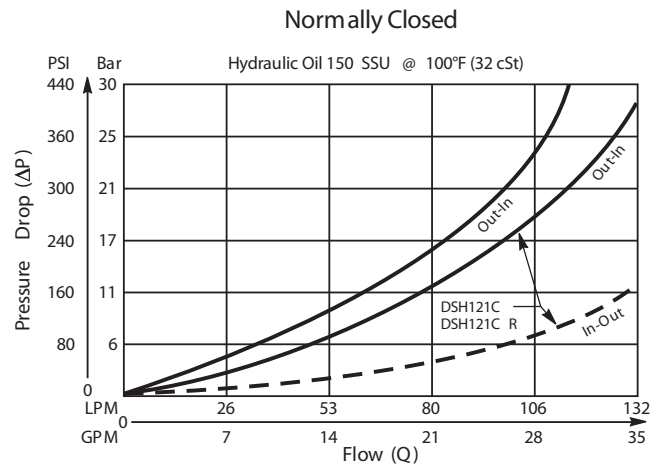

CV
Check Valves

SH
Shuttle Valves

LM
Load/Motor Controls

FC
Flow Controls

PC
Pressure Controls

LE
Logic Elements

DC
Directional Controls

SV
Solenoid Valves

PV
Proportional Valves

CE
Coils & Electronics

BC
Bodies & Cavities

TD
Technical Data

Dimensions Millimeters (Inches)

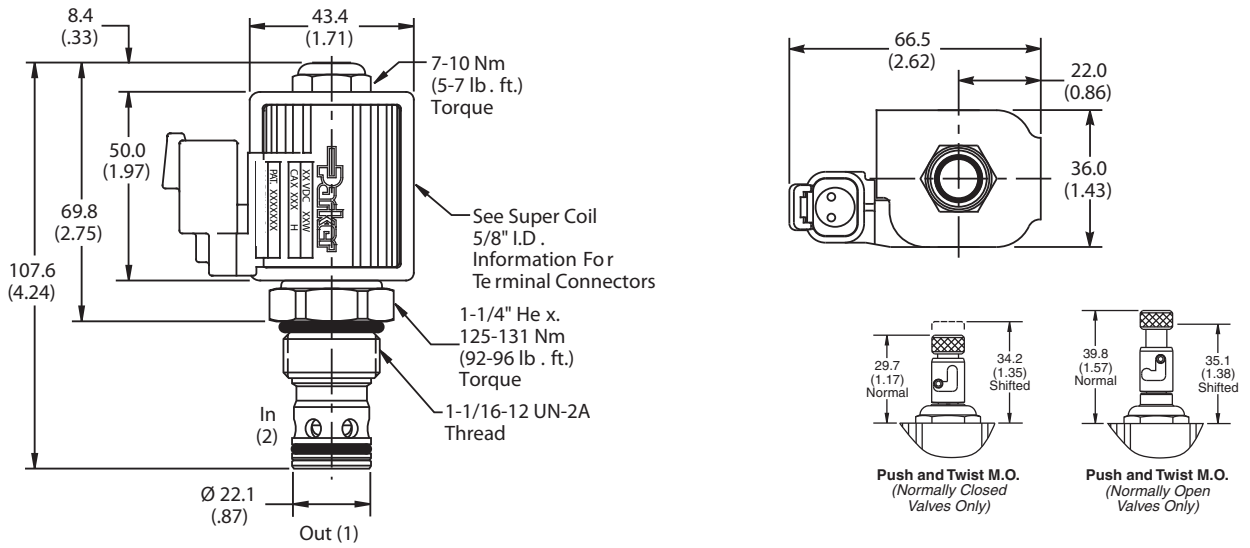

Ordering Information

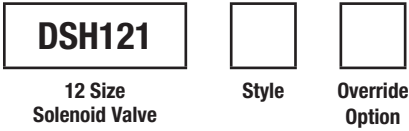

Highlighted represents preferred options that offer the shortest lead times. Other options may be available, but at extended lead times.

Coil(s) sold separately. Please see section CE of this catalog, 5/8" Super-Coil (CA series), for ordering information.

Order Bodies Separately
 See section BC

Code / Style	Symbol
C Normally Closed Metered reverse flow	
CR Normally Closed Free reverse flow	
N Normally Open Metered reverse flow	
NR Normally Open Free reverse flow	

Code	Override Options
Omit	None
T	Push & Twist (N.C. & N.O.)

Code	Seals
Omit	Nitrile

B12	2	8T
12 size	2-Way Cavity	Port Size
Code	Port Size / Body Material	
8T	SAE-8 / Steel (5000 PSI)	

Kit	Part Number
Nitrile Seal	SK12-2
Fluorocarbon Seal	SK12-2V

CV
Check Valves
SH
Shuttle Valves
LM
Load/Motor Controls
FC
Flow Controls
PC
Pressure Controls
LE
Logic Elements
DC
Directional Controls
SV
Solenoid Valves
PV
Proportional Valves
CE
Coils & Electronics
BC
Bodies & Cavities
TD
Technical Data

General Description

2-Way Poppet Valves.
 For additional information see Technical Tips on pages SV2-SV6.

Features

- Replaceable, one piece encapsulated coils with minimal amperage draw
- Various coil terminations and voltages
- Various manual override options
- All external parts zinc plated
- New 350 Bar (5000 PSI) rating

Specifications

Rated Flow	150 LPM (40 GPM)		
Maximum Inlet Pressure	350 Bar (5000 PSI)		
Leakage at 150 SSU (32 cSt)	5 drops/min. (.33 cc/min.)		
Minimum Operating Voltage	85% of rated voltage at 20°C (72°F).		
Response Time		Energized	De-Energized
	C, CR	50 ms	130 ms
	N, NR	45 ms	75 ms
Cartridge Material	All parts steel. All operating parts hardened steel.		
Operating Temp. Range/Seals	-34°C to +121°C (Nitrile) (-30°F to +250°F) -26°C to +204°C (Fluorocarbon) (-15°F to +400°F)		
Fluid Compatibility/Viscosity	Mineral-based or synthetic with lubricating properties at viscosities of 45 to 2000 SSU (6 to 420 cSt)		
Filtration	ISO 4406 18/16/13, SAE Class 4		
Approx. Weight	.34 kg (.75 lbs.)		
Cavity	C16-2 (See BC Section for more details)		

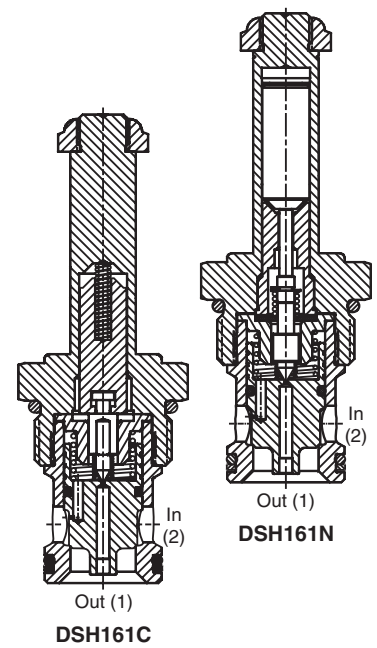
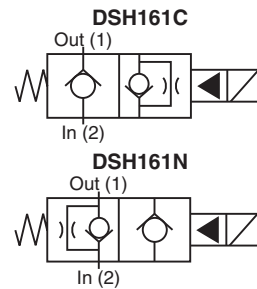

Performance Curves

Pressure Drop vs. Flow (Through cartridge only)

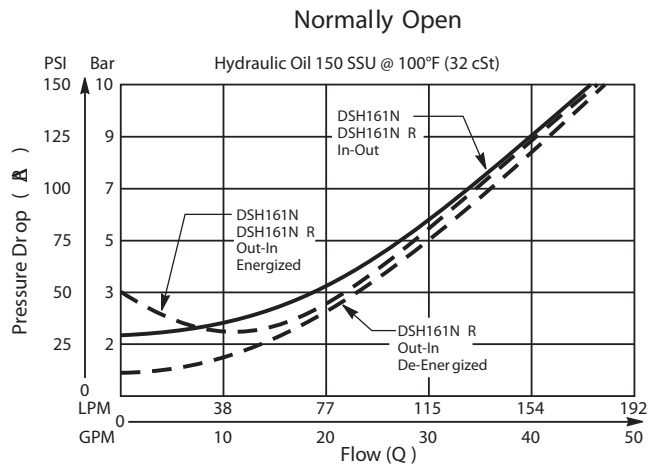
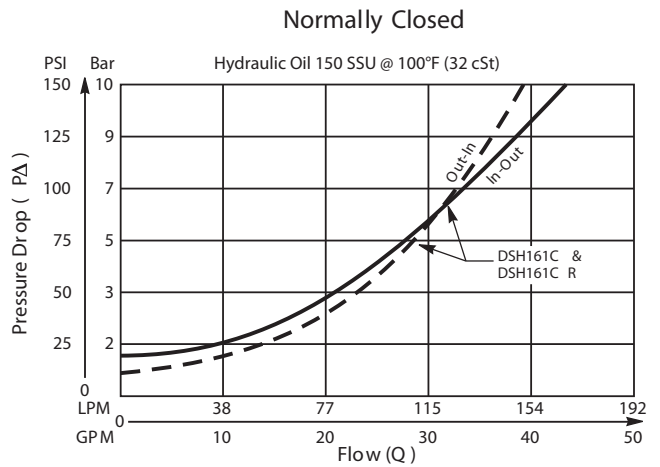

CV
Check Valves

SH
Shuttle Valves

LM
Load/Motor Controls

FC
Flow Controls

PC
Pressure Controls

LE
Logic Elements

DC
Directional Controls

SV
Solenoid Valves

PV
Proportional Valves

CE
Coils & Electronics

BC
Bodies & Cavities

TD
Technical Data

Dimensions Millimeters (Inches)

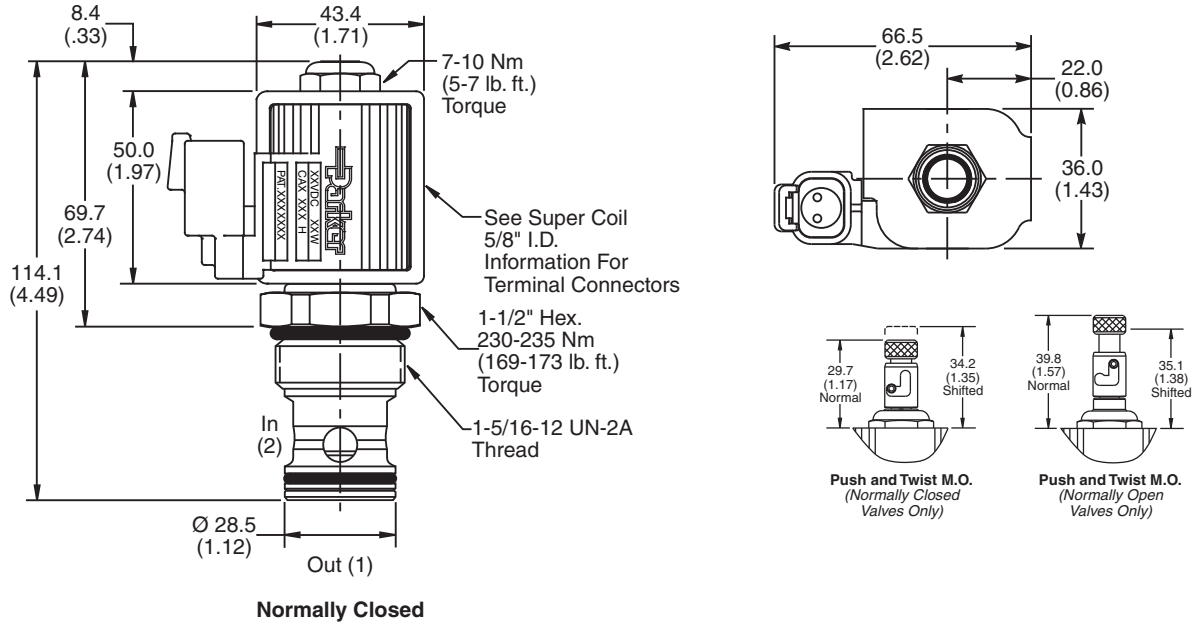

Ordering Information

DSH161

16 Size Solenoid Valve

Style

Override Option

Highlighted represents preferred options that offer the shortest lead times. Other options may be available, but at extended lead times.

Coil(s) sold separately. Please see section CE of this catalog, 5/8" Super-Coil (CA series), for ordering information.

Order Bodies Separately See section BC

Code / Style	Diagram
C Normally Closed Metered reverse flow	
CR Normally Closed Free reverse flow	
N Normally Open Metered reverse flow	
NR Normally Open Free reverse flow	

Code	Override Options
Omit	None
T	Push & Twist (N.C. & N.O.)

B16 - **2** - **16T**

16 size 2-Way Cavity Port Size

Code	Seals
Omit	Nitrile

Code	Port Size / Body Material
16T	SAE-16 / Steel (5000 PSI)

Kit	Part Number
Nitrile Seal	SK16-2
Fluorocarbon Seal	SK16-2V

CV
Check Valves

SH
Shuttle Valves

LM
Load/Motor Controls

FC
Flow Controls

PC
Pressure Controls

LE
Logic Elements

DC
Directional Controls

SV
Solenoid Valves

PV
Proportional Valves

CE
Coils & Electronics

BC
Bodies & Cavities

TD
Technical Data

General Description

2-Way Poppet Valves.
 For additional information see Technical Tips on pages SV2-SV6.

Features

- Replaceable, one piece encapsulated coils with minimal amperage draw
- Various coil terminations and voltages
- Various manual override options
- All external parts zinc plated
- New 250 Bar (3600 PSI) rating

Specifications

Rated Flow	260 LPM (70 GPM)		
Maximum Inlet Pressure	250 Bar (3600 PSI)		
Leakage at 150 SSU (32 cSt)	5 drops/min. (.33 cc/min.)		
Minimum Operating Voltage	85% of rated voltage at 20°C (72°F).		
Response Time		Energized	De-Energized
	C, CR	350 ms	160 ms
	N, NR	300 ms	45 ms
Cartridge Material	All parts steel. All operating parts hardened steel.		
Operating Temp. Range/Seals	-34°C to +121°C (Nitrile) (-30°F to +250°F) -26°C to +204°C (Fluorocarbon) (-15°F to +400°F)		
Fluid Compatibility/Viscosity	Mineral-based or synthetic with lubricating properties at viscosities of 45 to 2000 SSU (6 to 420 cSt)		
Filtration	ISO 4406 18/16/13, SAE Class 4		
Approx. Weight	.34 kg (.75 lbs.)		
Cavity	C20-2 (See BC Section for more details)		

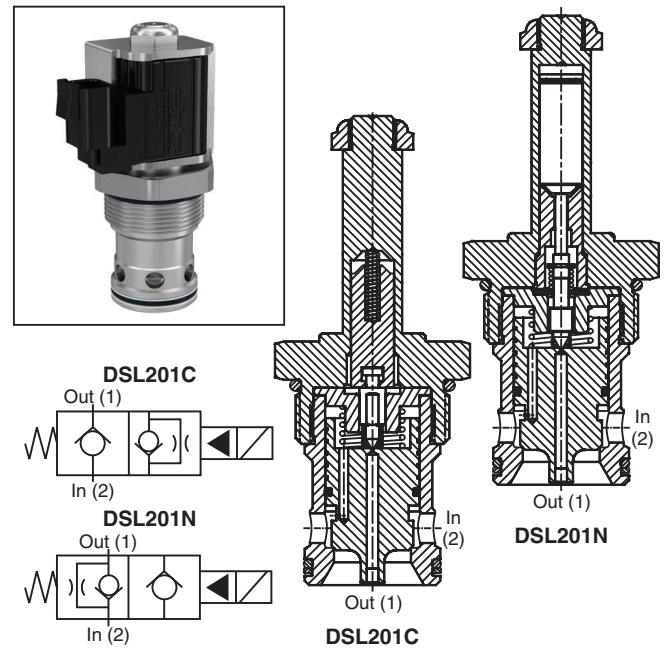

Performance Curve

Pressure Drop vs. Flow (Through cartridge only)

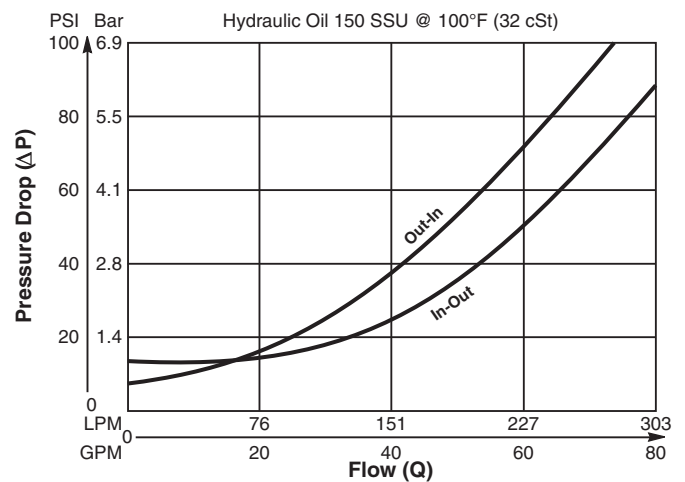

CV
Check Valves

SH
Shuttle Valves

LM
Load/Motor Controls

FC
Flow Controls

PC
Pressure Controls

LE
Logic Elements

DC
Directional Controls

SV
Solenoid Valves

PV
Proportional Valves

CE
Coils & Electronics

BC
Bodies & Cavities

TD
Technical Data

Dimensions Millimeters (Inches)

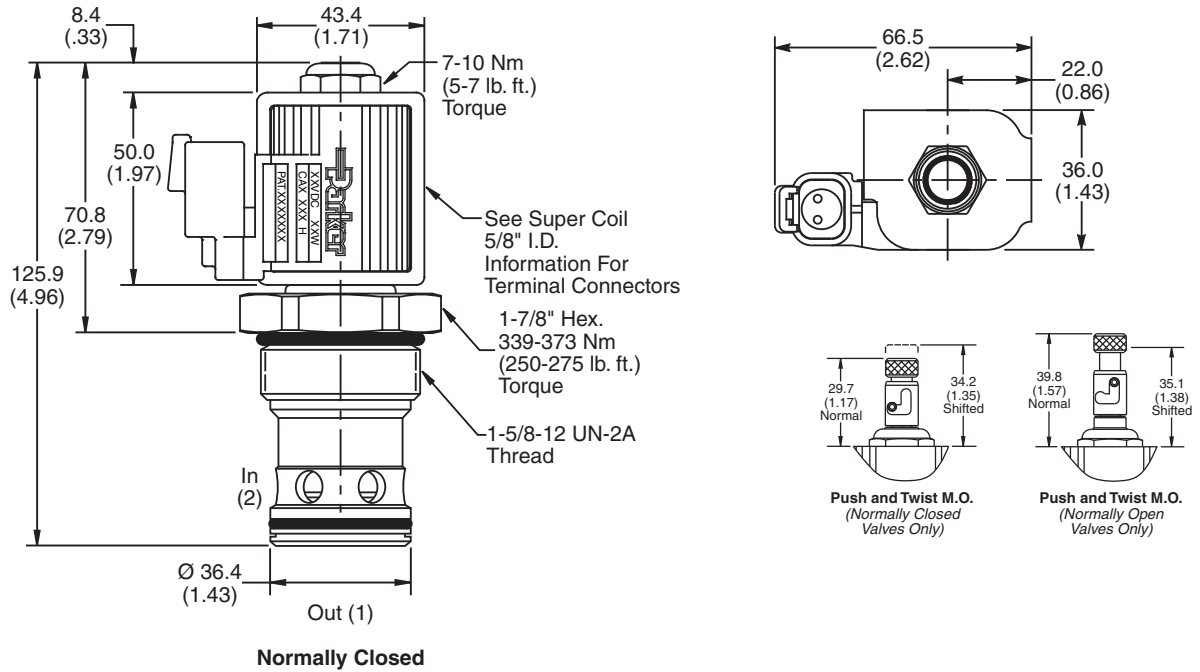

Ordering Information

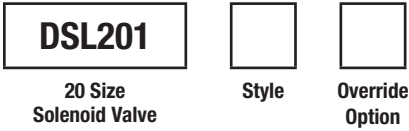

Highlighted represents preferred options that offer the shortest lead times. Other options may be available, but at extended lead times.

Coil(s) sold separately. Please see section CE of this catalog, 5/8" Super-Coil (CA series), for ordering information.

Order Bodies Separately
 See section BC

Code / Style	Diagram
C Normally Closed Metered reverse flow	
CR Normally Closed Free reverse flow	
N Normally Open Metered reverse flow	
NR Normally Open Free reverse flow	

Code	Override Options
Omit	None
T	Push & Twist (N.C. & N.O.)



Code	Seals
Omit	Nitrile

Code	Port Size / Body Material
20T	SAE-20 / Steel (5000 PSI)

Kit	Part Number
Nitrile Seal	SK20-2
Fluorocarbon Seal	SK20-2V



CV
Check Valves

SH
Shuttle Valves

LM
Load/Motor Controls

FC
Flow Controls

PC
Pressure Controls

LE
Logic Elements

DC
Directional Controls

SV
Solenoid Valves

PV
Proportional Valves

CE
Coils & Electronics

BC
Bodies & Cavities

TD
Technical Data

General Description

2-Way Poppet Valves.
 For additional information see Technical Tips on pages SV2-SV6.

Features

- Replaceable, one piece encapsulated, coils with minimal amperage draw
- Variety of coil terminations and voltages
- Polyurethane “D”-Ring eliminates need for backup rings
- Conical poppet for low leakage
- Nylon inserted jam-nut provides secure holding in high vibration applications
- All external parts zinc plated

Specifications

Rated Flow	1.1 LPM (0.3 GPM)									
Maximum Input Pressure at Port 1	250 Bar (3600 PSI)									
Leakage at 150 SSU (32 cSt)	5 drops/min. (0.33 cc/min.) @ 250 Bar (3600 PSI)									
Minimum Operating Voltage, CCXXX Coil	85% of rated voltage at 20°C (72°F).									
Response Time	<table border="1"> <thead> <tr> <th></th> <th>Energized</th> <th>De-Energized</th> </tr> </thead> <tbody> <tr> <td>C</td> <td>30 ms</td> <td>30 ms</td> </tr> <tr> <td>N</td> <td>30 ms</td> <td>30 ms</td> </tr> </tbody> </table>		Energized	De-Energized	C	30 ms	30 ms	N	30 ms	30 ms
	Energized	De-Energized								
C	30 ms	30 ms								
N	30 ms	30 ms								
Cartridge Material	All parts steel. All operating parts hardened steel.									
Operating Temp. Range/Seals	-37°C to +93°C (“D” ring) (-35°F to +200°F) -34°C to +121°C (Nitrile) (-30°F to +250°F) -26°C to +204°C (Fluorocarbon) (-15°F to +400°F)									
Fluid Compatibility/Viscosity	Mineral-based or synthetic with lubricating properties at viscosities of 45 to 2000 SSU (6 to 420 cSt)									
Filtration	ISO 4406 18/16/13, SAE Class 4									
Approx. Weight	.11 kg (.25 lbs.)									
Cavity	C08-2 (See BC Section for more details)									

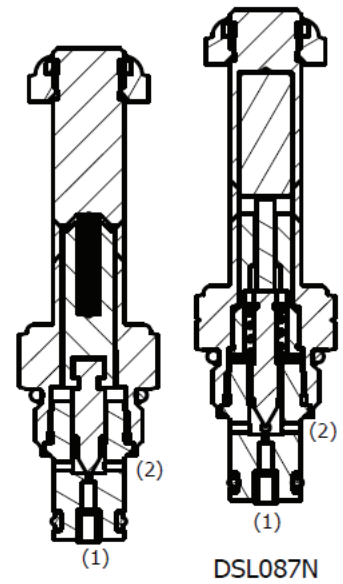
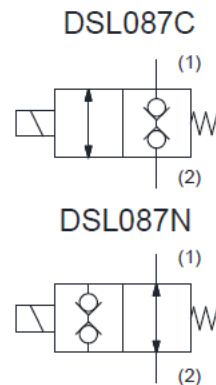
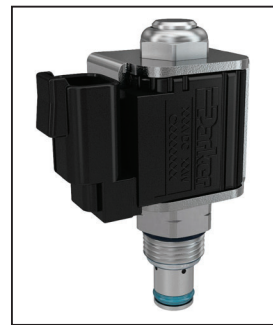

Performance Curve

Pressure Drop vs. Flow (Through cartridge only)

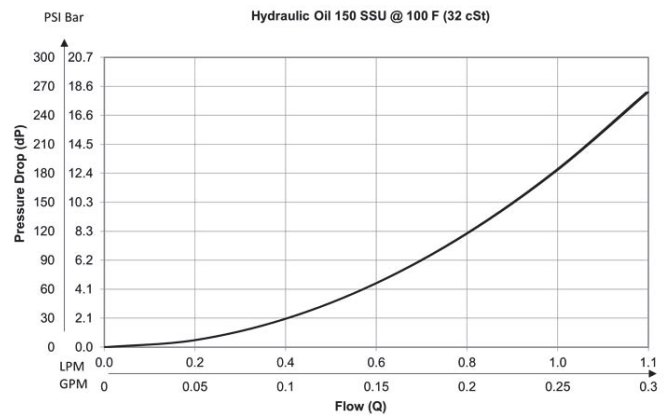

CV
Check Valves
SH
Shuttle Valves
LM
Load/Motor Controls
FC
Flow Controls
PC
Pressure Controls
LE
Logic Elements
DC
Directional Controls
SV
Solenoid Valves
PV
Proportional Valves
CE
Coils & Electronics
BC
Bodies & Cavities
TD
Technical Data

Dimensions Millimeters (Inches)

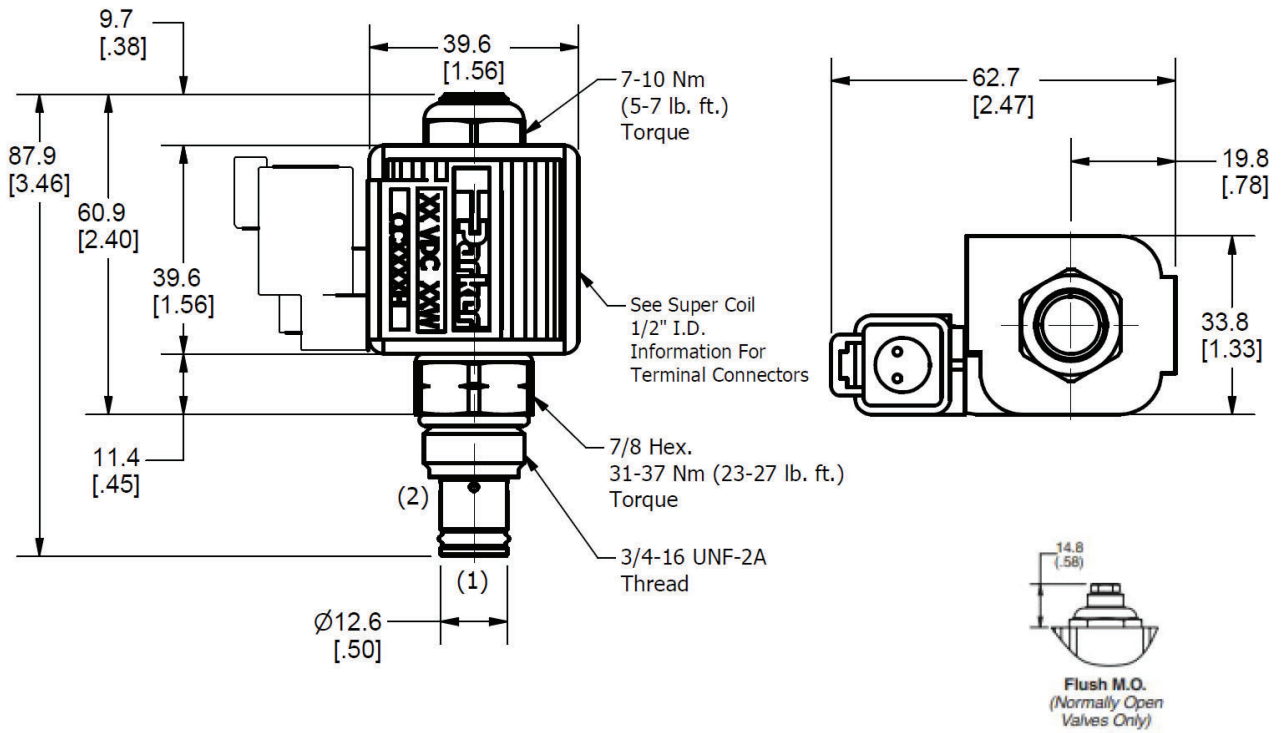

Ordering Information

DSL087	<input type="checkbox"/>	<input type="checkbox"/>	<input type="checkbox"/>
08 Size Solenoid Valve	Style	Override Option	Screens

Highlighted represents preferred options that offer the shortest lead times. Other options may be available, but at extended lead times.

Coil(s) sold separately. Please see section CE of this catalog, 1/2" Super-Coil (CC series), for ordering information.
REQUIRES LOW WATT (CCS) Coil

Order Bodies Separately
 See section BC

Code	Style
C	Normally Closed
N	Normally Open

Code	Seals
Omit	D-ring

B08	—	2	—	6T
08 size		2-Way Cavity		Port Size

Code	Port Size / Body Material
6T	SAE-6 / Steel (5000 PSI)

Code	Override Options
Omit	None
M	Push Type with Flush Rod (N.O. Only)

Code	Screen
Omit	None
S	Screen

Kit	Part Number
D-Ring Seal	SK08-2
Nitrile Seal	SK08-2
Fluorocarbon Seal	SK08-2V

CV
Check Valves
SH
Shuttle Valves
LM
Load/Motor Controls
FC
Flow Controls
PC
Pressure Controls
LE
Logic Elements
DC
Directional Controls
SV
Solenoid Valves
PV
Proportional Valves
CE
Coils & Electronics
BC
Bodies & Cavities
TD
Technical Data

General Description

2-Way, 2 Position, Normally Closed, Bi-Directional Poppet Valve. For additional information see Technical Tips on pages SV2-SV6.

Features

- Built-in thermal relief set at 36 Bar (500 PSI) above rated pressure
- One piece cartridge housing ensures internal concentricity
- Coil: Waterproof, hermetically sealed, requires no O’Rings; Coil is interchangeable with 04 and 06 series poppet valves; Symmetrical coil can be reversed without affecting performance.

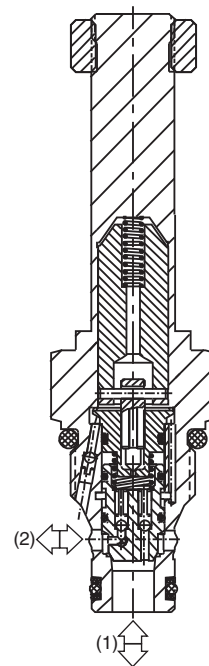
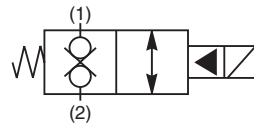

Specifications

Rated Flow	2 to 1 34 LPM (9 GPM) 1 to 2 19 LPM (5 GPM)
Maximum Inlet Pressure	81 350 Bar (5000 PSI)
Leakage at 150 SSU (32 cSt)	5 drops/min. (.33 cc/min.)
Minimum Operating Voltage	85% of rated voltage at 20°C (72°F).
Response Time	Open 40 ms Close 40 ms
Cartridge Material	All parts steel. All operating parts hardened steel.
Operating Temp. Range/Seals	-34°C to +121°C (Nitrile) (-30°F to +250°F) -26°C to +204°C (Fluorocarbon) (-15°F to +400°F)
Fluid Compatibility/Viscosity	Mineral-based or synthetic with lubricating properties at viscosities of 45 to 2000 SSU (6 to 420 cSt)
Filtration	ISO 4406 18/16/13, SAE Class 4
Approx. Weight	.14 kg (.31 lbs.)
Cavity	C08-2 (See BC Section for more details)

Performance Curve

Pressure Drop vs. Flow (Through cartridge only)

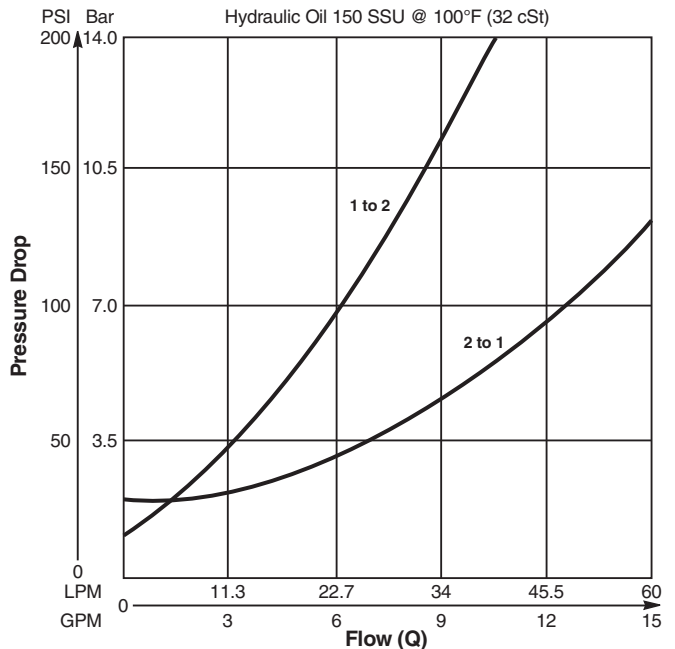

CV
Check Valves

SH
Shuttle Valves

LM
Load/Motor Controls

FC
Flow Controls

PC
Pressure Controls

LE
Logic Elements

DC
Directional Controls

SV
Solenoid Valves

PV
Proportional Valves

CE
Coils & Electronics

BC
Bodies & Cavities

TD
Technical Data

Dimensions Millimeters (Inches)

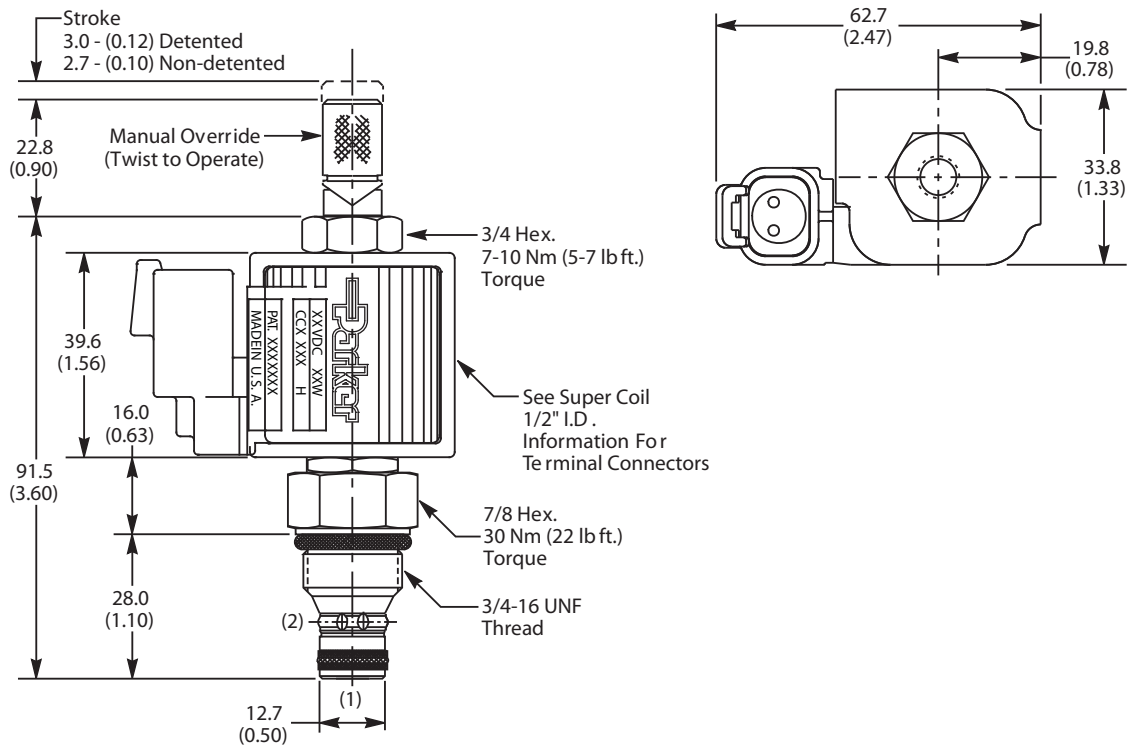

Ordering Information

GS02	81		0	N
08 Size Solenoid Valve	Style Normally Closed	Override Option	Screen	Seals

Highlighted represents preferred options that offer the shortest lead times. Other options may be available, but at extended lead times.

Coil(s) sold separately. Please see section CE of this catalog, 1/2" Super-Coil (CC series), for ordering information.

Code	Style
81	High Pressure ('SP' Coil)

Code	Screen
0	None

Code	Override Options
0	None
1	Detented

Code	Seals
N	Nitrile

Order Bodies Separately
 See section BC

B08	-	2	-	6T
08 size		2-Way Cavity		Port Size

Code	Port Size / Body Material
6T	SAE-6 / Steel (5000 PSI)

Kit	Part Number
Nitrile Seal	SK30088N-1
Fluorocarbon Seal	SK30088V-1

CV
Check Valves
SH
Shuttle Valves
LM
Load/Motor Controls
FC
Flow Controls
PC
Pressure Controls
LE
Logic Elements
DC
Directional Controls
SV
Solenoid Valves
PV
Proportional Valves
CE
Coils & Electronics
BC
Bodies & Cavities
TD
Technical Data

General Description

2-Way, 2 Position, Normally Closed, Bi-Directional Poppet Valve. For additional information see Technical Tips on pages SV2-SV6.

Features

- Built-in thermal relief set at 36 Bar (500 PSI) above rated pressure
- One piece cartridge housing ensures internal concentricity
- Coil: Waterproof, hermetically sealed, requires no O-Rings; Coil is interchangeable with 02 and 06 series poppet valves; Symmetrical coil can be reversed without affecting performance.

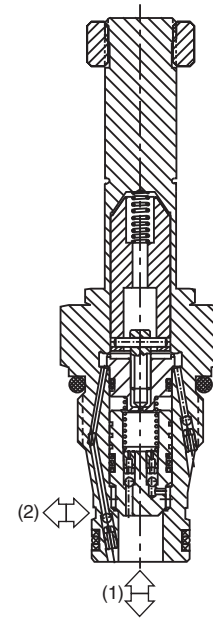
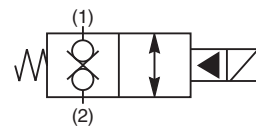
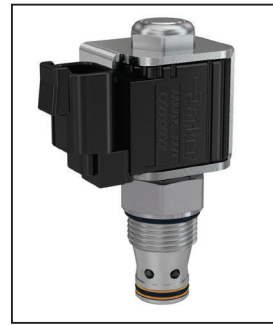

Specifications

Rated Flow	2 to 1 68 LPM (18 GPM) 1 to 2 46 LPM (12 GPM)
Maximum Inlet Pressure	81 350 Bar (5000 PSI)
Leakage at 150 SSU (32 cSt)	5 drops/min. (.33 cc/min.)
Minimum Operating Voltage	85% of rated voltage at 20°C (72°F).
Response Time	See Performance Curves
Cartridge Material	All parts steel. All operating parts hardened steel.
Operating Temp. Range/Seals	-34°C to +121°C (Nitrile) (-30°F to +250°F) -26°C to +204°C (Fluorocarbon) (-15°F to +400°F)
Fluid Compatibility/Viscosity	Mineral-based or synthetic with lubricating properties at viscosities of 45 to 2000 SSU (6 to 420 cSt)
Filtration	ISO 4406 18/16/13, SAE Class 4
Approx. Weight	.17 kg (.37 lbs.)
Cavity	2R (See BC Section for more details)

Performance Curves

Pressure Drop vs. Flow (Through cartridge only)

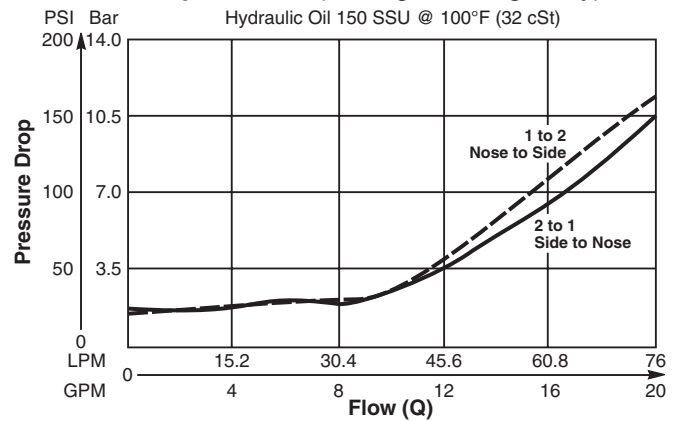

Response Time vs. Flow

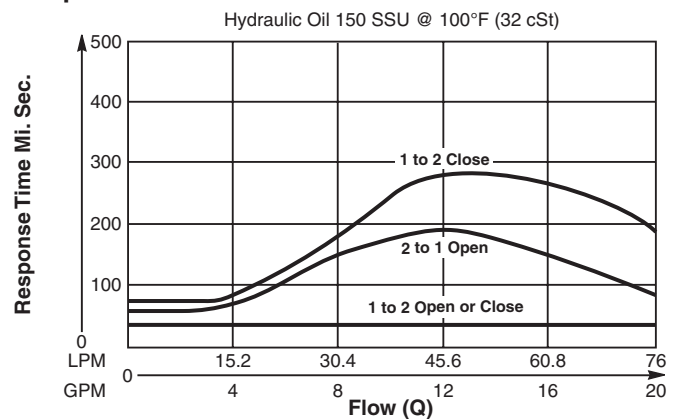

CV
Check Valves
SH
Shuttle Valves
LM
Load/Motor Controls
FC
Flow Controls
PC
Pressure Controls
LE
Logic Elements
DC
Directional Controls
SV
Solenoid Valves
PV
Proportional Valves
CE
Coils & Electronics
BC
Bodies & Cavities
TD
Technical Data

Dimensions Millimeters (Inches)

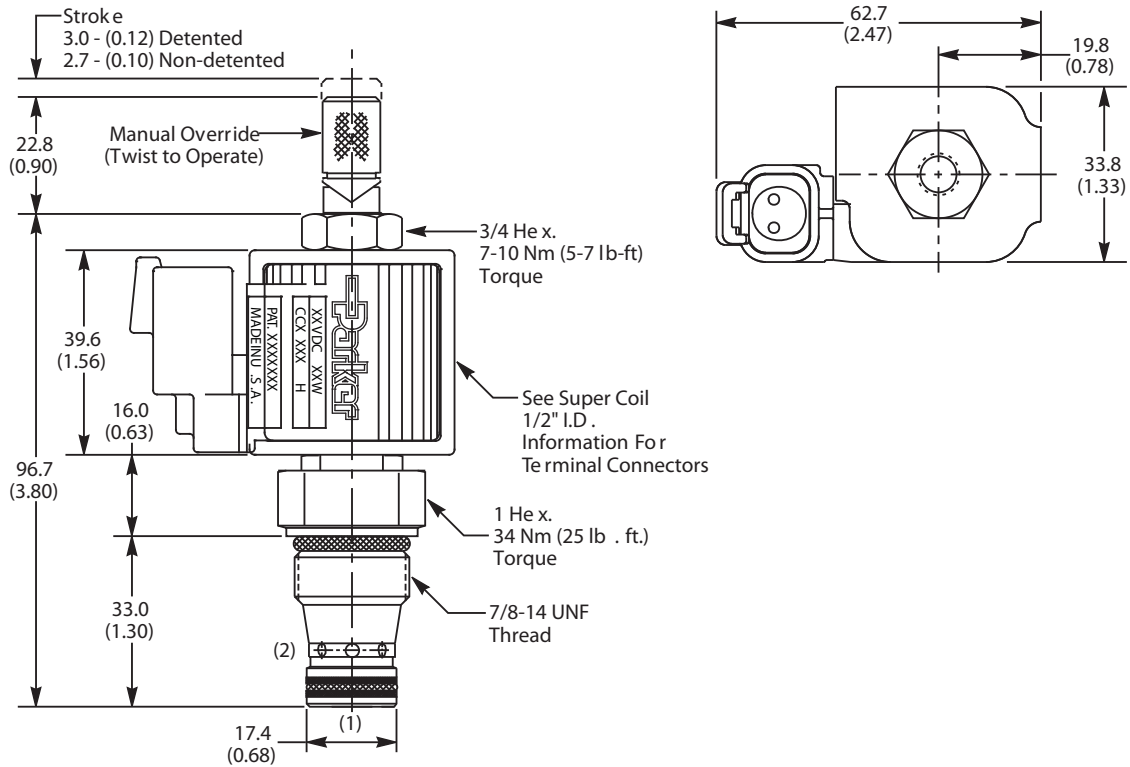

Ordering Information

GS04	81		0	N
10 Size Solenoid Valve	Style Normally Closed	Override Option	Screen	Seals

Highlighted represents preferred options that offer the shortest lead times. Other options may be available, but at extended lead times.

Coil(s) sold separately. Please see section CE of this catalog, 1/2" Super-Coil (CC series), for ordering information.

Code	Style
81	High Pressure ('SP' Coil)

Code	Screen
0	None

Code	Override Options
0	None
2	Non-Detented

Code	Seals
N	Nitrile

*Order Bodies Separately
 See section BC*

BW14	2	8T
14 size	2-Way Cavity	Port Size

Code	Port Size / Body Material
8T	SAE-8 / Steel (5000 PSI)

Kit	Part Number
Nitrile Seal	SK30113N-1
Fluorocarbon Seal	SK30113V-1



CV
Check Valves
SH
Shuttle Valves
LM
Load/Motor Controls
FC
Flow Controls
PC
Pressure Controls
LE
Logic Elements
DC
Directional Controls
SV
Solenoid Valves
PV
Proportional Valves
CE
Coils & Electronics
BC
Bodies & Cavities
TD
Technical Data

General Description

2-Way, 2 Position, Normally Closed, Bi-Directional Poppet Valve. For additional information see Technical Tips on pages SV2-SV6.

Features

- Built-in thermal relief set at 36 Bar (500 PSI) above rated pressure
- One piece cartridge housing ensures internal concentricity
- Coil: Waterproof, hermetically sealed, requires no O-Rings; Coil is interchangeable with 02 and 04 series poppet valves; Symmetrical coil can be reversed without affecting performance.

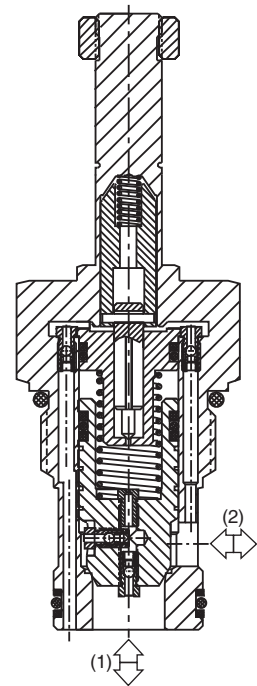
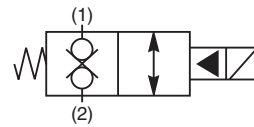

Specifications

Rated Flow	285 LPM (75 GPM)
Maximum Inlet Pressure	81 350 Bar (5000 PSI)
Leakage at 150 SSU (32 cSt)	9 drops/min. (.58 cc/min.)
Minimum Operating Voltage	85% of rated voltage at 20°C (72°F).
Response Time	See Performance Curves
Cartridge Material	All parts steel. All operating parts hardened steel.
Operating Temp. Range/Seals	-34°C to +121°C (Nitrile) (-30°F to +250°F) -26°C to +204°C (Fluorocarbon) (-15°F to +400°F)
Fluid Compatibility/Viscosity	Mineral-based or synthetic with lubricating properties at viscosities of 45 to 2000 SSU (6 to 420 cSt)
Filtration	ISO 4406 18/16/13, SAE Class 4
Approx. Weight	0.4 kg (.88 lbs.)
Cavity	C16-2 (See BC Section for more details)

Performance Curves

Pressure Drop vs. Flow (Through cartridge only)

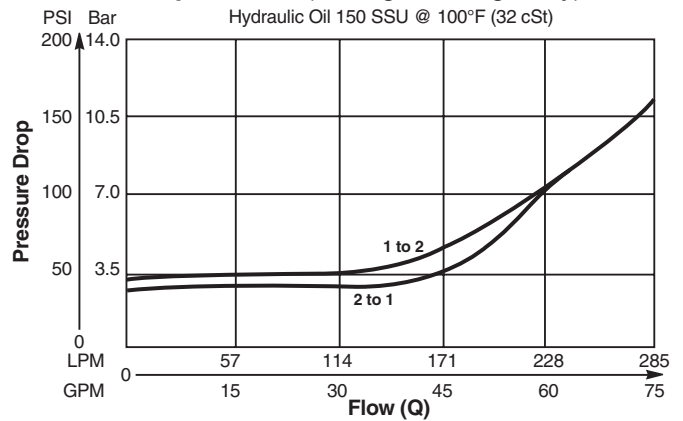

Response Time vs. Flow

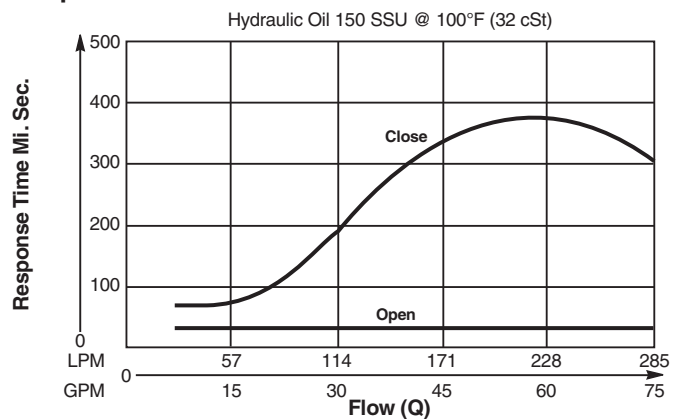

CV
Check Valves

SH
Shuttle Valves

LM
Load/Motor Controls

FC
Flow Controls

PC
Pressure Controls

LE
Logic Elements

DC
Directional Controls

SV
Solenoid Valves

PV
Proportional Valves

CE
Coils & Electronics

BC
Bodies & Cavities

TD
Technical Data

Dimensions Millimeters (Inches)

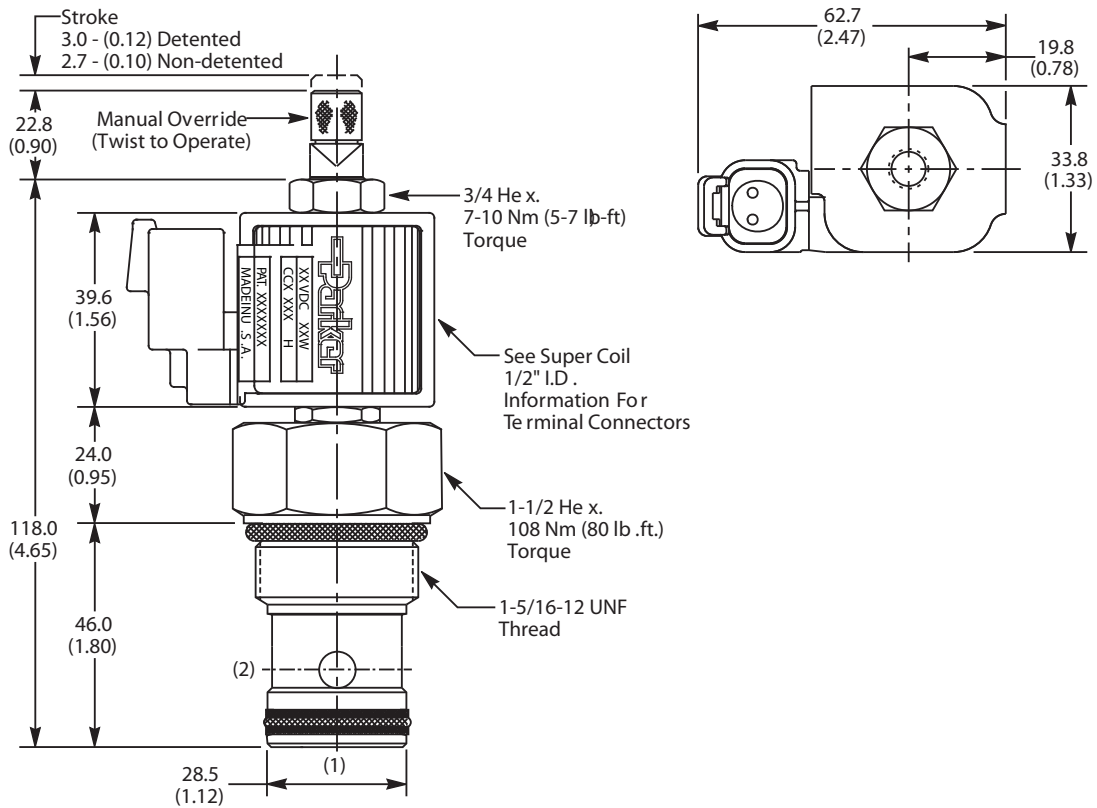

Ordering Information

GS06	81		0	N
16 Size Solenoid Valve	Style Normally Closed	Override Option	Screen	Seals

Highlighted represents preferred options that offer the shortest lead times. Other options may be available, but at extended lead times.

Coil(s) sold separately. Please see section CE of this catalog, 1/2" Super-Coil (CC series), for ordering information.

Code	Style
81	High Pressure ('SP' Coil)

Code	Screen
0	None

Code	Override Options
0	None
2	Non-Detented

Code	Seals
N	Nitrile

Order Bodies Separately
 See section BC

B16	—	2	—	16T
16 size		2-Way Cavity		Port Size

Code	Port Size / Body Material
16T	SAE-16 / Steel (5000 PSI)

Kit	Part Number
Nitrile Seal	SK30089N-1
Fluorocarbon Seal	SK30089V-1

CV
Check Valves
SH
Shuttle Valves
LM
Load/Motor Controls
FC
Flow Controls
PC
Pressure Controls
LE
Logic Elements
DC
Directional Controls
SV
Solenoid Valves
PV
Proportional Valves
CE
Coils & Electronics
BC
Bodies & Cavities
TD
Technical Data

General Description

2-Way, 2 Position, Normally Open, Bi-Directional Poppet Valve. For additional information see Technical Tips on pages SV2-SV6.

Features

- Built-in thermal relief set at 36 Bar (500 PSI) above rated pressure
- One piece cartridge housing ensures internal concentricity
- Coil: Waterproof, hermetically sealed, requires no O-Rings; Coil is interchangeable with 04 and 06 series poppet valves; Symmetrical coil can be reversed without affecting performance.

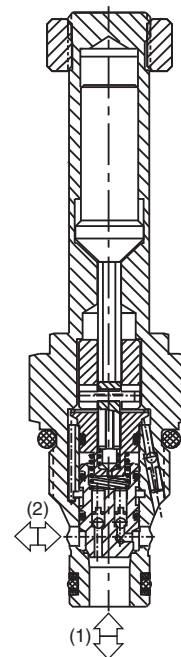
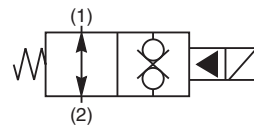

Specifications

Rated Flow	2 to 1 34 LPM (9 GPM) 1 to 2 19 LPM (5 GPM)
Maximum Inlet Pressure	86 350 Bar (5000 PSI)
Leakage at 150 SSU (32 cSt)	5 drops/min. (.33 cc/min.)
Minimum Operating Voltage	85% of rated voltage at 20°C (72°F).
Response Time	Open 40 ms Close 40 ms
Cartridge Material	All parts steel. All operating parts hardened steel.
Operating Temp. Range/Seals	-34°C to +121°C (Nitrile) (-30°F to +250°F) -26°C to +204°C (Fluorocarbon) (-15°F to +400°F)
Fluid Compatibility/Viscosity	Mineral-based or synthetic with lubricating properties at viscosities of 45 to 2000 SSU (6 to 420 cSt)
Filtration	ISO 4406 18/16/13, SAE Class 4
Approx. Weight	.14 kg (.31 lbs.)
Cavity	C08-2 (See BC Section for more details)

Performance Curve

Pressure Drop vs. Flow (Through cartridge only)

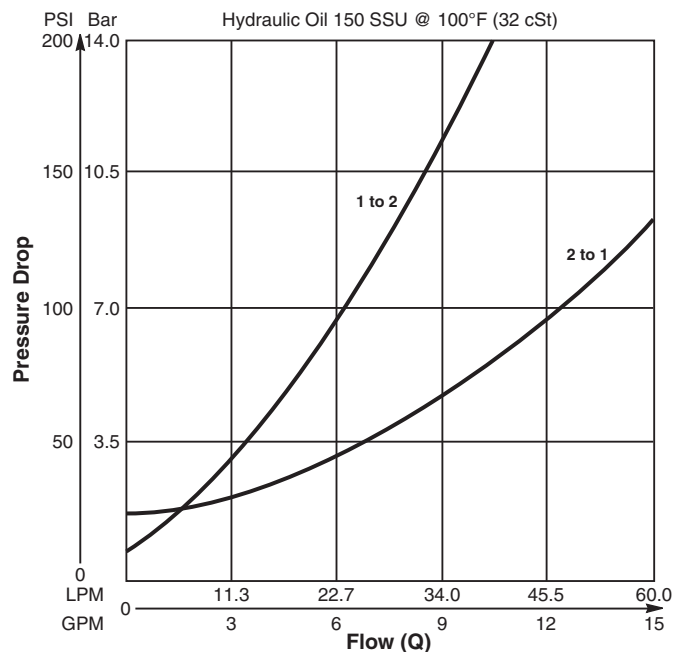

- CV Check Valves
- SH Shuttle Valves
- LM Load/Motor Controls
- FC Flow Controls
- PC Pressure Controls
- LE Logic Elements
- DC Directional Controls
- SV Solenoid Valves
- PV Proportional Valves
- CE Coils & Electronics
- BC Bodies & Cavities
- TD Technical Data

Dimensions Millimeters (Inches)

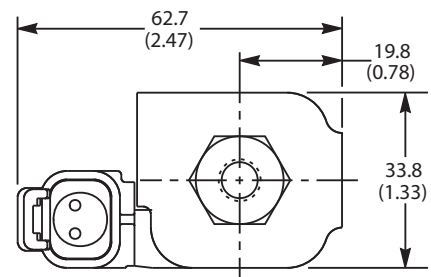
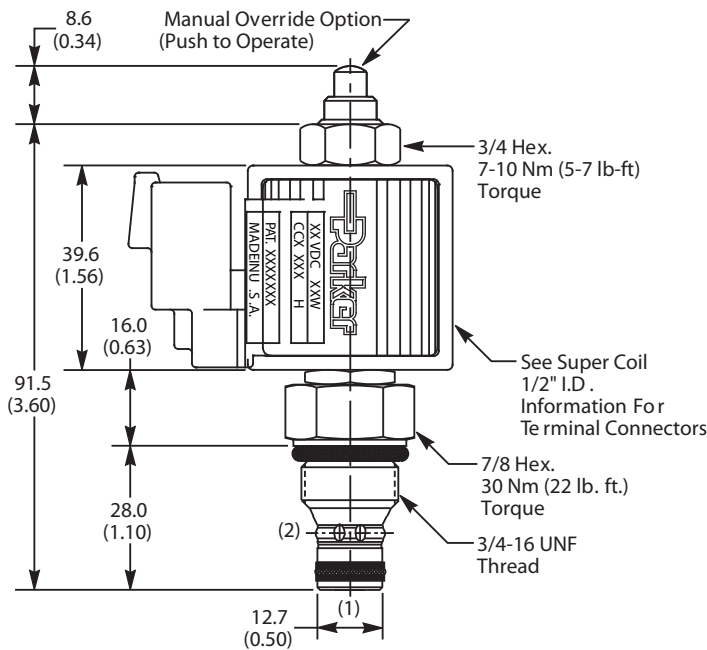

Ordering Information

GS02	86		0	N
08 Size Solenoid Valve	Style Normally Open	Override Option	Screen	Seals

Highlighted represents preferred options that offer the shortest lead times. Other options may be available, but at extended lead times.

Coil(s) sold separately. Please see section CE of this catalog, 1/2" Super-Coil (CC series), for ordering information.

Code	Style
86	High Pressure ('SP' Coil)

Code	Screen
0	None

Code	Override Options
0	None
1	Manual Override

Code	Seals
N	Nitrile

Order Bodies Separately
 See section BC

B08	—	2	—	6T
08 size		2-Way Cavity		Port Size

Code	Port Size / Body Material
6T	SAE-6 / Steel (5000 PSI)

Kit	Part Number
Nitrile Seal	SK30088N-1
Fluorocarbon Seal	SK30088V-1



CV
Check Valves
SH
Shuttle Valves
LM
Load/Motor Controls
FC
Flow Controls
PC
Pressure Controls
LE
Logic Elements
DC
Directional Controls
SV
Solenoid Valves
PV
Proportional Valves
CE
Coils & Electronics
BC
Bodies & Cavities
TD
Technical Data

General Description

2-Way, 2 Position, Normally Open, Bi-Directional Poppet Valve. For additional information see Technical Tips on pages SV2-SV6.

Features

- Built-in thermal relief set at 36 Bar (500 PSI) above rated pressure
- One piece cartridge housing ensures internal concentricity
- Coil: Waterproof, hermetically sealed, requires no O-Rings; Coil is interchangeable with 02 and 06 series poppet valves; Symmetrical coil can be reversed without affecting performance.

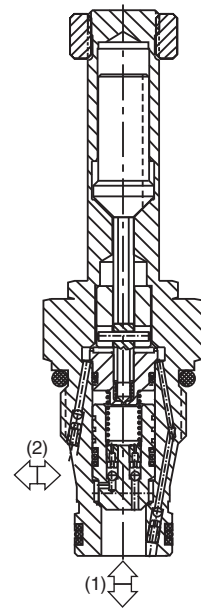
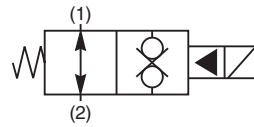
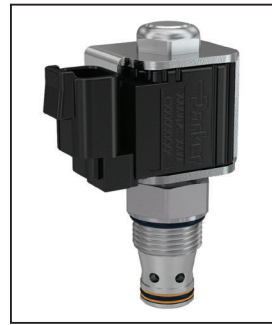

Specifications

Rated Flow	2 to 1 68 LPM (18 GPM) 1 to 2 46 LPM (12 GPM)
Maximum Inlet Pressure	86 350 Bar (5000 PSI)
Leakage at 150 SSU (32 cSt)	5 drops/min. (.33 cc/min.)
Minimum Operating Voltage	85% of rated voltage at 20°C (72°F).
Response Time	See Performance Curves
Cartridge Material	All parts steel. All operating parts hardened steel.
Operating Temp. Range/Seals	-34°C to +121°C (Nitrile) (-30°F to +250°F) -26°C to +204°C (Fluorocarbon) (-15°F to +400°F)
Fluid Compatibility/Viscosity	Mineral-based or synthetic with lubricating properties at viscosities of 45 to 2000 SSU (6 to 420 cSt)
Filtration	ISO 4404 18/16/13, SAE Class 4
Approx. Weight	.17 kg (.37 lbs.)
Cavity	2R (See BC Section for more details)

Performance Curves

Pressure Drop vs. Flow (Through cartridge only)

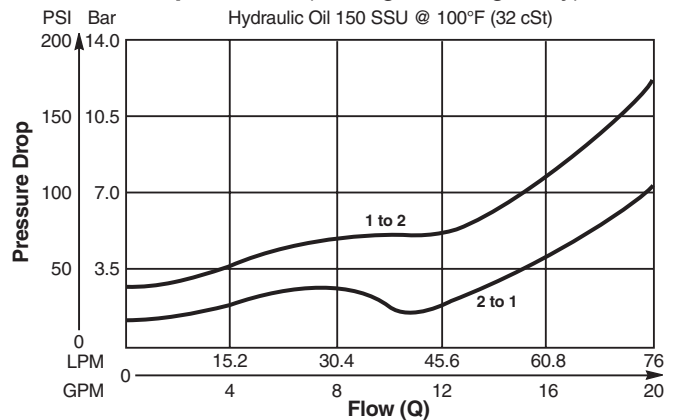

Response Time vs. Flow

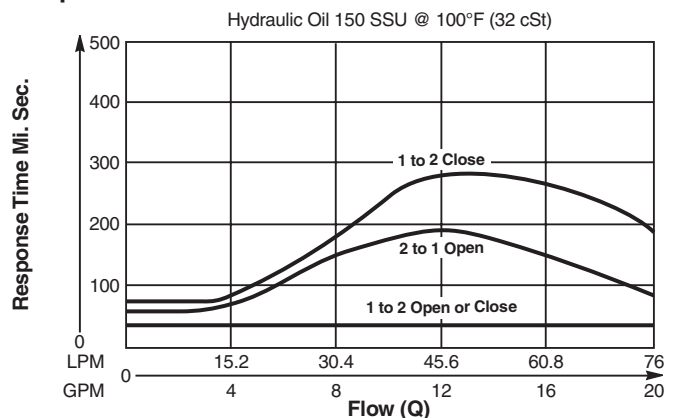

CV
Check Valves
SH
Shuttle Valves
LM
Load/Motor Controls
FC
Flow Controls
PC
Pressure Controls
LE
Logic Elements
DC
Directional Controls
SV
Solenoid Valves
PV
Proportional Valves
CE
Coils & Electronics
BC
Bodies & Cavities
TD
Technical Data

Dimensions Millimeters (Inches)

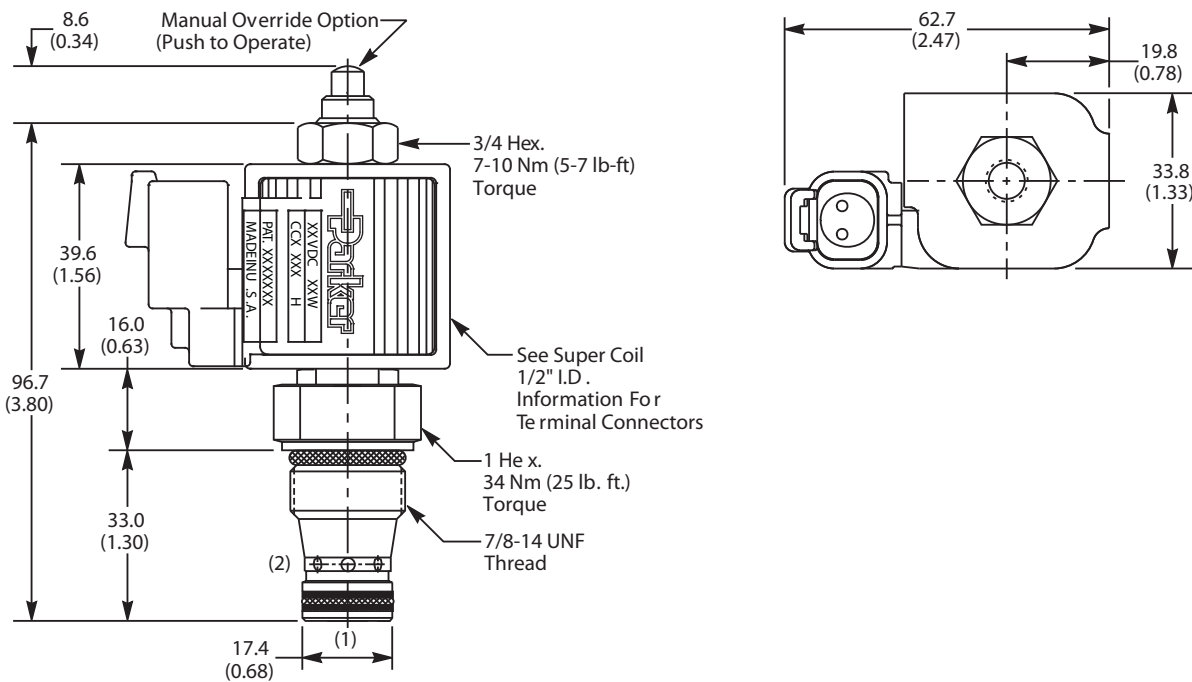

Ordering Information

GS04	86		0	N
10 Size Solenoid Valve	Style Normally Open	Override Option	Screen	Seals

Highlighted represents preferred options that offer the shortest lead times. Other options may be available, but at extended lead times.

Coil(s) sold separately. Please see section CE of this catalog, 1/2" Super-Coil (CC series), for ordering information.

Code	Style
86	High Pressure ('SP' Coil)

Code	Screen
0	None

Code	Override Options
0	None
1	Manual Override

Code	Seals
N	Nitrile

Order Bodies Separately See section BC

BW14	2	8T
14 size	2-Way Cavity	Port Size

Code	Port Size / Body Material
8T	SAE-8 / Steel (5000 PSI)

Kit	Part Number
Nitrile Seal	SK30113N-1
Fluorocarbon Seal	SK30113V-1



CV
Check Valves
SH
Shuttle Valves
LM
Load/Motor Controls
FC
Flow Controls
PC
Pressure Controls
LE
Logic Elements
DC
Directional Controls
SV
Solenoid Valves
PV
Proportional Valves
CE
Coils & Electronics
BC
Bodies & Cavities
TD
Technical Data

General Description

2-Way, 2 Position, Normally Open, Bi-Directional Poppet Valve. For additional information see Technical Tips on pages SV2-SV6.

Features

- Built-in thermal relief set at 36 Bar (500 PSI) above rated pressure
- One piece cartridge housing ensures internal concentricity
- Coil: Waterproof, hermetically sealed, requires no O-Rings; Coil is interchangeable with 02 and 04 series poppet valves; Symmetrical coil can be reversed without affecting performance.

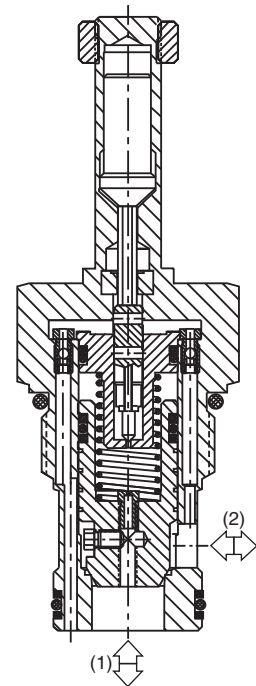
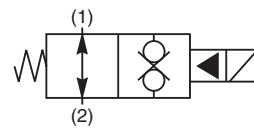

Specifications

Rated Flow	285 LPM (75 GPM)
Maximum Inlet Pressure	86 350 Bar (5000 PSI)
Leakage at 150 SSU (32 cSt)	5 drops/min. (.33 cc/min.)
Minimum Operating Voltage	85% of rated voltage at 20°C (72°F).
Response Time	See Performance Curves
Cartridge Material	All parts steel. All operating parts hardened steel.
Operating Temp. Range/Seals	-34°C to +121°C (Nitrile) (-30°F to +250°F) -26°C to +204°C (Fluorocarbon) (-15°F to +400°F)
Fluid Compatibility/Viscosity	Mineral-based or synthetic with lubricating properties at viscosities of 45 to 2000 SSU (6 to 420 cSt)
Filtration	ISO 4406 18/16/13, SAE Class 4
Approx. Weight	0.4 kg (.88 lbs.)
Cavity	C16-2 (See BC Section for more details)

Performance Curves

Pressure Drop vs. Flow (Through cartridge only)

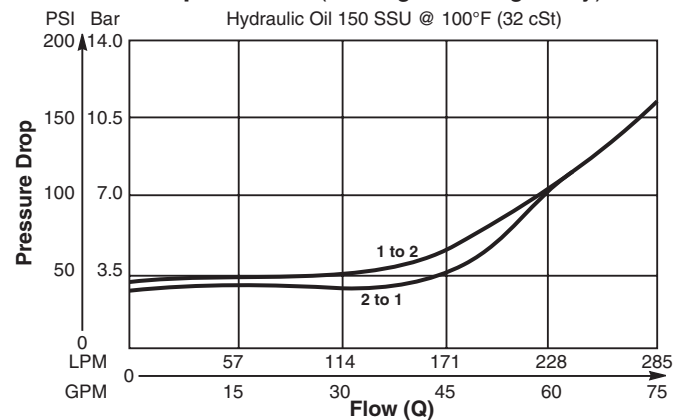

Response Time vs. Flow

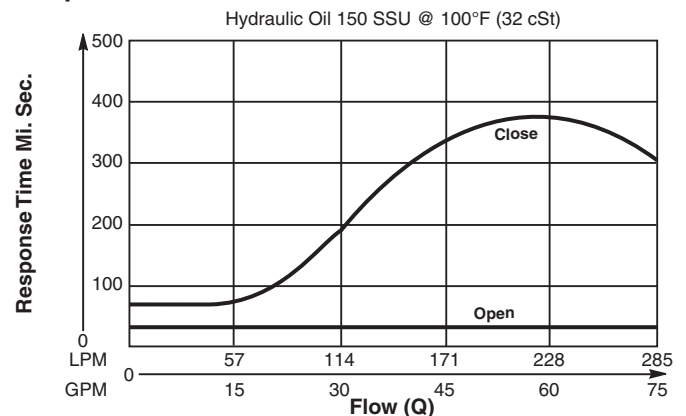

CV
Check Valves

SH
Shuttle Valves

LM
Load/Motor Controls

FC
Flow Controls

PC
Pressure Controls

LE
Logic Elements

DC
Directional Controls

SV
Solenoid Valves

PV
Proportional Valves

CE
Coils & Electronics

BC
Bodies & Cavities

TD
Technical Data

Dimensions Millimeters (Inches)

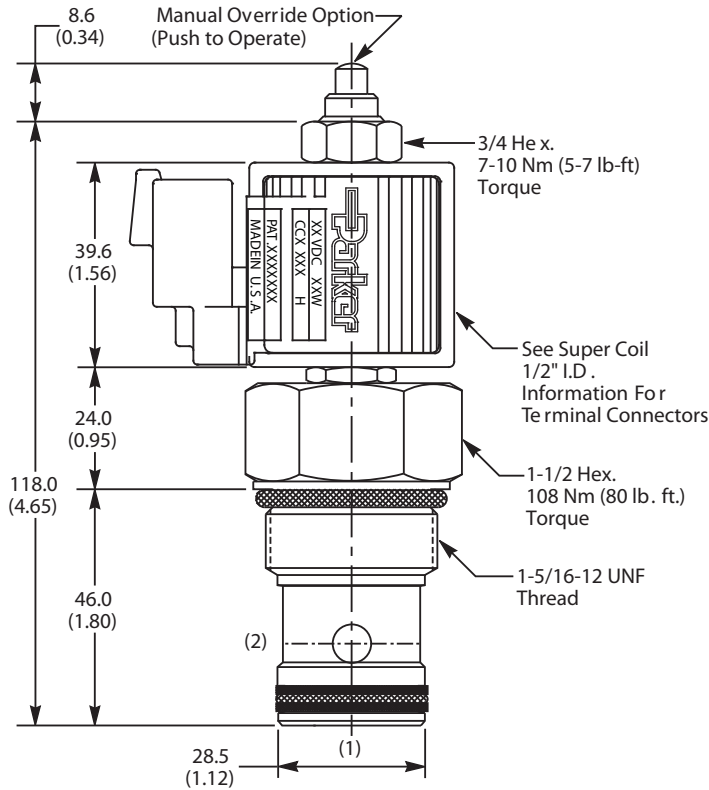

Ordering Information

GS06	86		0	N
16 Size Solenoid Valve	Style Normally Open	Override Option	Screen	Seals

Highlighted represents preferred options that offer the shortest lead times. Other options may be available, but at extended lead times.

Coil(s) sold separately. Please see section CE of this catalog, 1/2" Super-Coil (CC series), for ordering information.

Code	Style
86	High Pressure ('SP' Coil)

Code	Screen
0	None

Code	Override Options
0	None
1	Manual Override

Code	Seals
N	Nitrile

Order Bodies Separately
 See section BC

B16	-	2	-	16T
16 size		2-Way Cavity		Port Size

Code	Port Size / Body Material
16T	SAE-16 / Steel (5000 PSI)

Kit	Part Number
Nitrile Seal	SK30089N-1
Fluorocarbon Seal	SK30089V-1



CV
Check Valves
SH
Shuttle Valves
LM
Load/Motor Controls
FC
Flow Controls
PC
Pressure Controls
LE
Logic Elements
DC
Directional Controls
SV
Solenoid Valves
PV
Proportional Valves
CE
Coils & Electronics
BC
Bodies & Cavities
TD
Technical Data

General Description

2-Way Spool Valves.

For additional information see Technical Tips on pages SV2-SV6.

Features

- High flow capacity with reduced space requirements
- Standard valve bodies and common cavities
- One-piece encapsulated coil with minimal amperage draw
- Manual overrides, seal variations and other options available
- No dynamic seals
- Variety of coil terminations
- Polyurethane “D”-Ring eliminates need for backup rings
- Nylon inserted jam-nut provides secure holding in high vibration applications
- All external parts zinc plated

Specifications

Rated Flow	C - 15.0 LPM (4 GPM) N - 8.4 LPM (2.8 GPM)									
Maximum Inlet Pressure	350 Bar (5000 PSI)									
Leakage at 150 SSU (32 cSt)	160 cc/min. (10 in ³ /min.) at 350 Bar (5000 PSI)									
Minimum Operating Voltage	85% of rated voltage at 20°C (72°F).									
Response Time	<table border="1"> <tr> <th></th> <th>Energized</th> <th>De-Energized</th> </tr> <tr> <td>C</td> <td>40 ms</td> <td>40 ms</td> </tr> <tr> <td>N</td> <td>40 ms</td> <td>40 ms</td> </tr> </table>		Energized	De-Energized	C	40 ms	40 ms	N	40 ms	40 ms
	Energized	De-Energized								
C	40 ms	40 ms								
N	40 ms	40 ms								
Cartridge Material	All parts steel. All operating parts hardened steel.									
Operating Temp. Range/Seals	-37°C to +93°C (“D”-Ring) (-35°F to +200°F) -34°C to +121°C (Nitrile) (-30°F to +250°F) -26°C to +204°C (Fluorocarbon) (-15°F to +400°F)									
Fluid Compatibility/Viscosity	Mineral-based or synthetic with lubricating properties at viscosities of 45 to 2000 SSU (6 to 420 cSt)									
Filtration	ISO 4406 18/16/13, SAE Class 4									
Approx. Weight	.11 kg (.25 lbs.)									
Cavity	C08-2 (See BC Section for more details)									

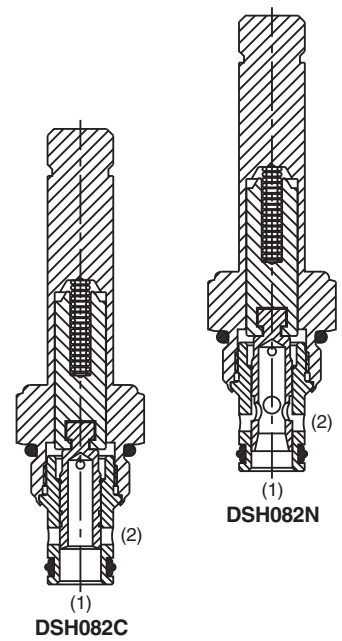
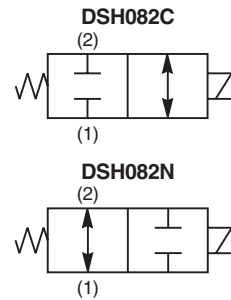

Performance Curves

Pressure Drop vs. Flow (Through cartridge only)

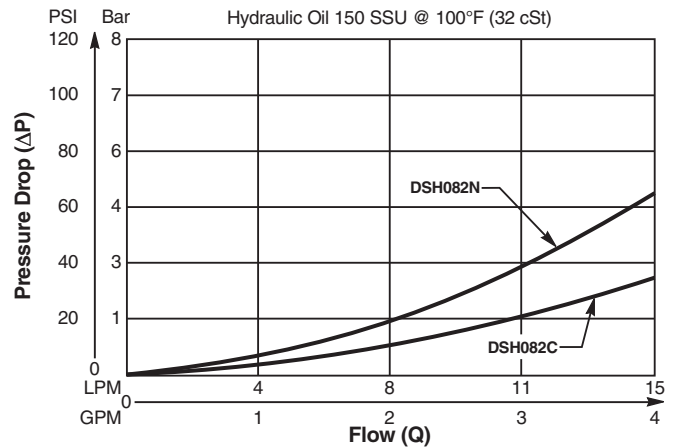

Shift Limit Characteristics (Min. Operating Voltage)

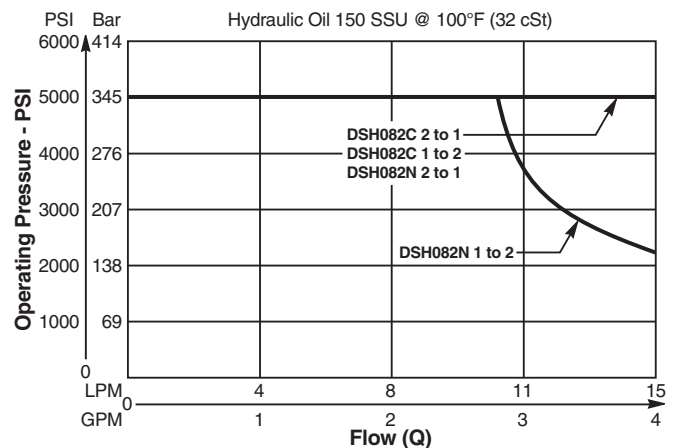

CV
Check Valves
SH
Shuttle Valves
LM
Load/Motor Controls
FC
Flow Controls
PC
Pressure Controls
LE
Logic Elements
DC
Directional Controls
SV
Solenoid Valves
PV
Proportional Valves
CE
Coils & Electronics
BC
Bodies & Cavities
TD
Technical Data

Dimensions Millimeters (Inches)

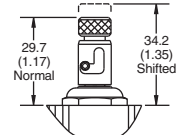
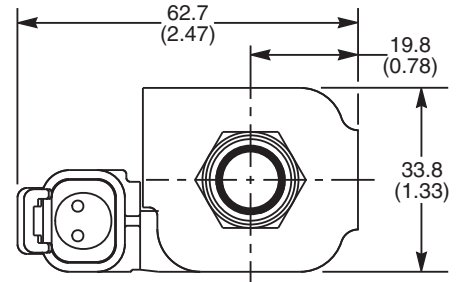
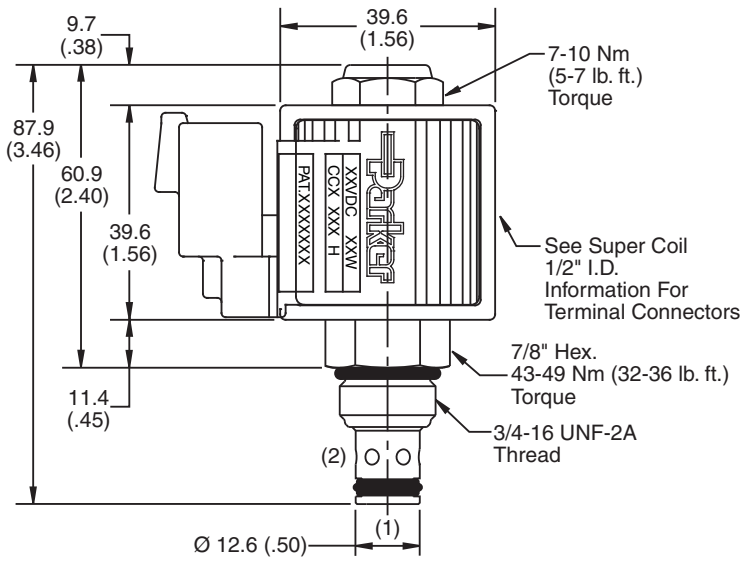

Push and Twist M.O.

Ordering Information

DSH082		
08 Size Solenoid Valve	Style	Override Option

Highlighted represents preferred options that offer the shortest lead times. Other options may be available, but at extended lead times.

Coil(s) sold separately. Please see section CE of this catalog, 1/2" Super-Coil (CC series), for ordering information.

Order Bodies Separately
 See section BC

B08	—	2	—	6T
08 size		2-Way Cavity		Port Size

Code	Port Size / Body Material
6T	SAE-6 / Steel (5000 PSI)

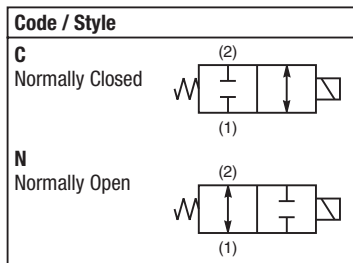

Code	Override Options
Omit	None
T	Push & Twist* (N.C. & N.O.)

*Requires Super Coil.

Code	Seals
Omit	"D"-Ring

Kit	Part Number
D-Ring Seal	SK08-2
Nitrile Seal	SK08-2
Fluorocarbon Seal	SK08-2V

CV
Check Valves
SH
Shuttle Valves
LM
Load/Motor Controls
FC
Flow Controls
PC
Pressure Controls
LE
Logic Elements
DC
Directional Controls
SV
Solenoid Valves
PV
Proportional Valves
CE
Coils & Electronics
BC
Bodies & Cavities
TD
Technical Data

General Description

2-Way Spool Valves. For additional information see Technical Tips on pages SV2-SV6.

Features

- High flow capacity with reduced space requirements
- Standard valve bodies and common cavities
- One-piece encapsulated coil with minimal amperage draw
- Manual overrides, seal variations and other options available
- No dynamic seals
- Variety of coil terminations
- Polyurethane “D”-Ring eliminates need for backup rings
- Nylon inserted jam-nut provides secure holding in high vibration applications
- All external parts zinc plated

Specifications

Rated Flow	C - 30 LPM (8.0 GPM) N - 19 LPM (5.0 GPM)									
Maximum Inlet Pressure	350 Bar (5000 PSI)									
Leakage at 150 SSU (32 cSt)	160 cc/min. (10 in ³ /min.)									
Minimum Operating Voltage	85% of rated voltage at 20°C (72°F).									
Response Time	<table border="1"> <thead> <tr> <th></th> <th>Energized</th> <th>De-Energized</th> </tr> </thead> <tbody> <tr> <td>C</td> <td>30 ms</td> <td>20 ms</td> </tr> <tr> <td>N</td> <td>50 ms</td> <td>25 ms</td> </tr> </tbody> </table>		Energized	De-Energized	C	30 ms	20 ms	N	50 ms	25 ms
	Energized	De-Energized								
C	30 ms	20 ms								
N	50 ms	25 ms								
Cartridge Material	All parts steel. All operating parts hardened steel.									
Operating Temp. Range/Seals	-37°C to +93°C (“D”-Ring) (-35°F to +200°F) -34°C to +121°C (Nitrile) (-30°F to +250°F) -26°C to +204°C (Fluorocarbon) (-15°F to +400°F)									
Fluid Compatibility/Viscosity	Mineral-based or synthetic with lubricating properties at viscosities of 45 to 2000 SSU (6 to 420 cSt)									
Filtration	ISO 4406 18/16/13, SAE Class 4									
Approx. Weight	.18 kg (.40 lbs.)									
Cavity	C10-2 (See BC Section for more details)									

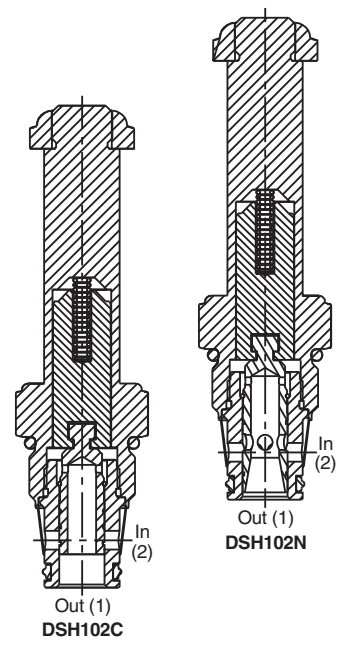
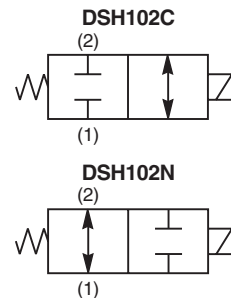

Performance Curves

Pressure Drop vs. Flow (Through cartridge only)

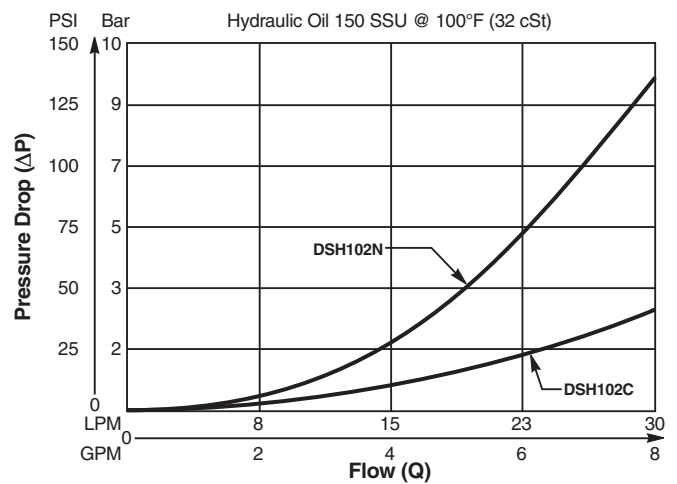

Shift Limit Characteristics (Min. Operating Voltage)

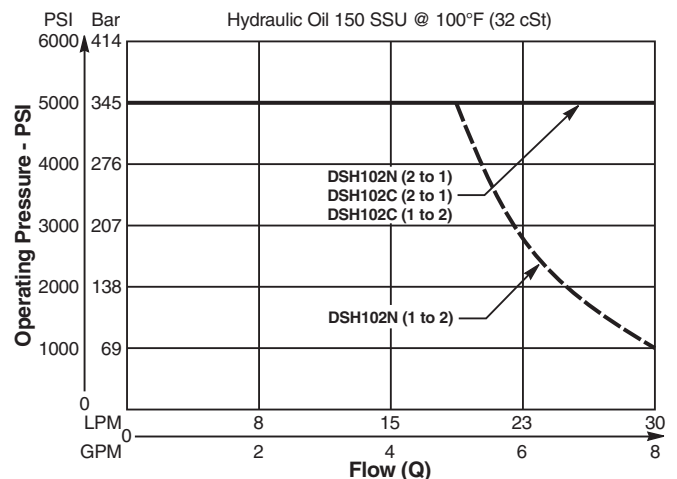

- CV Check Valves
- SH Shuttle Valves
- LM Load/Motor Controls
- FC Flow Controls
- PC Pressure Controls
- LE Logic Elements
- DC Directional Controls
- SV Solenoid Valves
- PV Proportional Valves
- CE Coils & Electronics
- BC Bodies & Cavities
- TD Technical Data

Dimensions Millimeters (Inches)

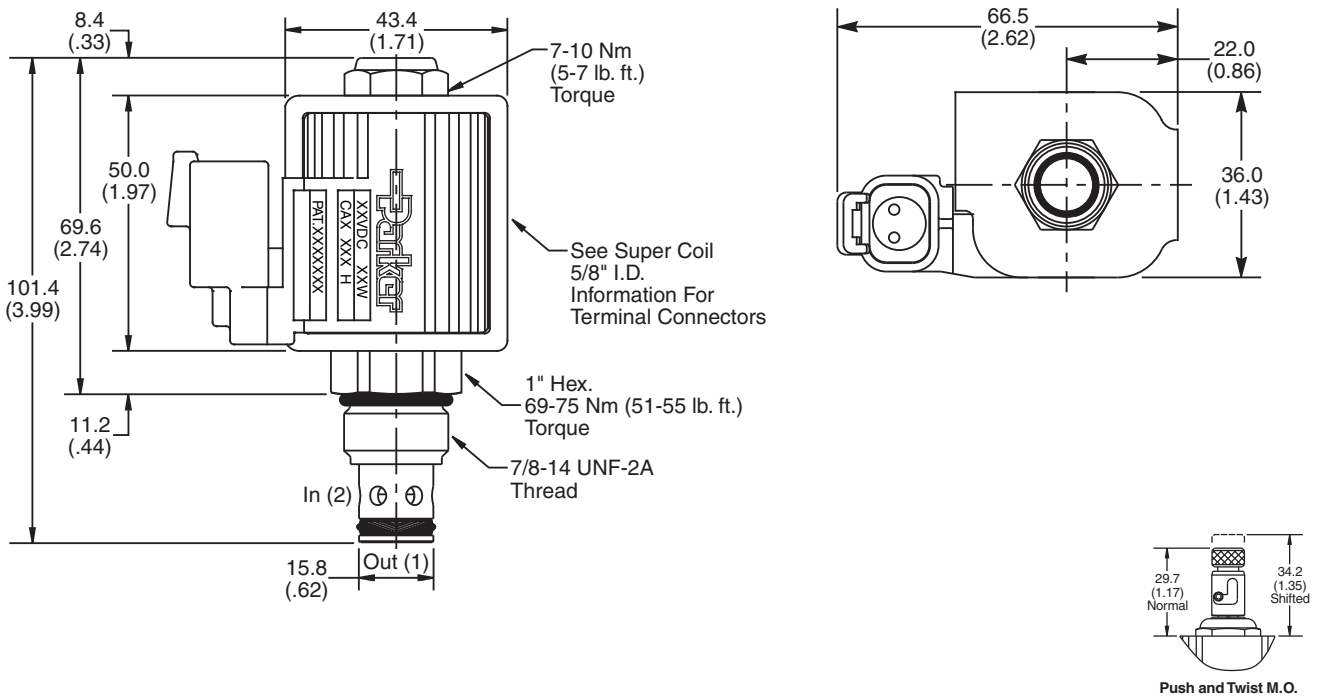

Ordering Information

DSH102	□	□
10 Size Solenoid Valve	Style	Override Option

Highlighted represents preferred options that offer the shortest lead times. Other options may be available, but at extended lead times.

Coil(s) sold separately. Please see section CE of this catalog, 5/8" Super-Coil (CA series), for ordering information.

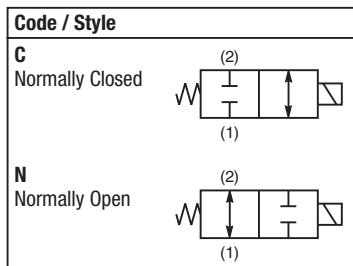

Code	Override Options
Omit	None
T	Push & Twist* (N.C. & N.O.)

Code	Seals
Omit	"D"-Ring

Kit	Part Number
D-Ring Seal	SK10-2
Nitrile Seal	SK10-2
Fluorocarbon Seal	SK10-2V

Order Bodies Separately
 See section BC

B10	—	2	—	8T
10 size		2-Way Cavity		Port Size

Code	Port Size / Body Material
8T	SAE-8 / Steel (5000 PSI)

General Description

3-Way Spool Valves. For additional information see Technical Tips on pages SV2-SV6.

Features

- High flow capacity with reduced space requirements
- Standard valve bodies and common cavities
- One piece encapsulated coils with minimal amperage draw
- Manual overrides, seal variations and other options available
- No dynamic seals
- Variety of coil terminations
- Polyurethane “D”-Ring eliminates need for backup rings
- Nylon inserted jam-nut provides secure holding in high vibration applications
- All external parts zinc plated

Specifications

Rated Flow	DSH083A	N.O.	11.3 LPM (3.0 GPM)
		N.C.	7.5 LPM (2.0 GPM)
		Selector	7.5 LPM (2.0 GPM)
	DSH083B	N.C.	15.0 LPM (4.0 GPM)
		Selector	15.0 LPM (4.0 GPM)
	DSH083N	N.O.	11.3 LPM (3.0 GPM)
		Selector	15.0 LPM (4.0 GPM)
Maximum Inlet Pressure	350 Bar (5000 PSI)		
Leakage at 150 SSU (32 cSt)	160 cc/min. (10 in ³ /min.) at 350 Bar (5000 PSI) DSH083B - 250 cc/min. (15 in ³ /min.) DSH083N - 250 cc/min. (15 in ³ /min.)		
Minimum Operating Voltage	85% of rated voltage at 20°C (72°F).		
Response Time	50 ms		
Cartridge Material	All parts steel. All operating parts hardened steel.		
Operating Temp. Range/Seals	-37°C to +93°C (“D”-Ring) (-35°F to +200°F) -34°C to +121°C (Nitrile) (-30°F to +250°F) -26°C to +204°C (Fluorocarbon) (-15°F to +400°F)		
Fluid Compatibility/Viscosity	Mineral-based or synthetic with lubricating properties at viscosities of 45 to 2000 SSU (6 to 420 cSt)		
Filtration	ISO 4406 18/16/13, SAE Class 4		
Approx. Weight	.13 kg (.28 lbs.)		
Cavity	C08-3 (See BC Section for more details)		

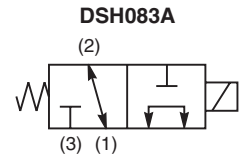

Construction/Symbols

DSH083A

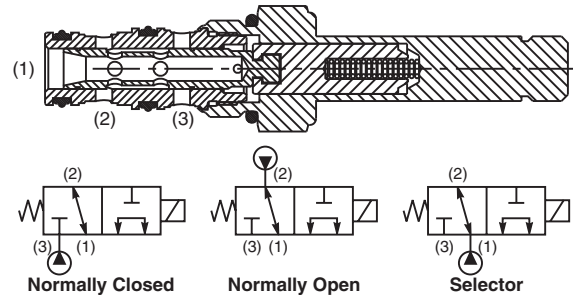

DSH083B

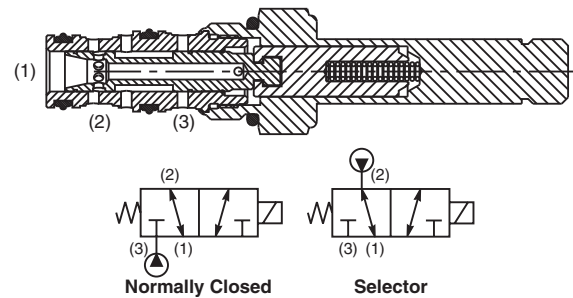

DSH083N

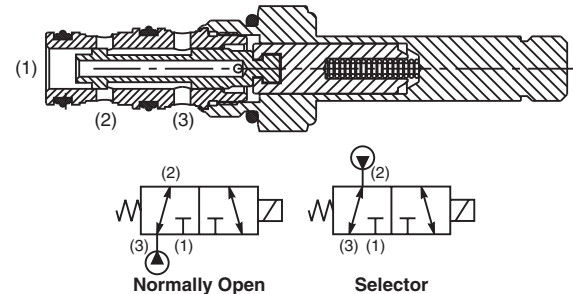

CV
Check Valves

SH
Shuttle Valves

LM
Load/Motor Controls

FC
Flow Controls

PC
Pressure Controls

LE
Logic Elements

DC
Directional Controls

SV
Solenoid Valves

PV
Proportional Valves

CE
Coils & Electronics

BC
Bodies & Cavities

TD
Technical Data

Dimensions Millimeters (Inches)

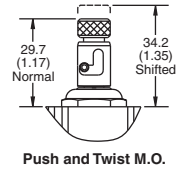
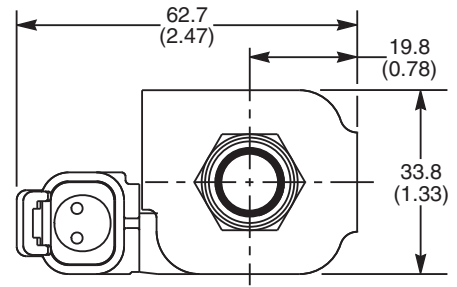
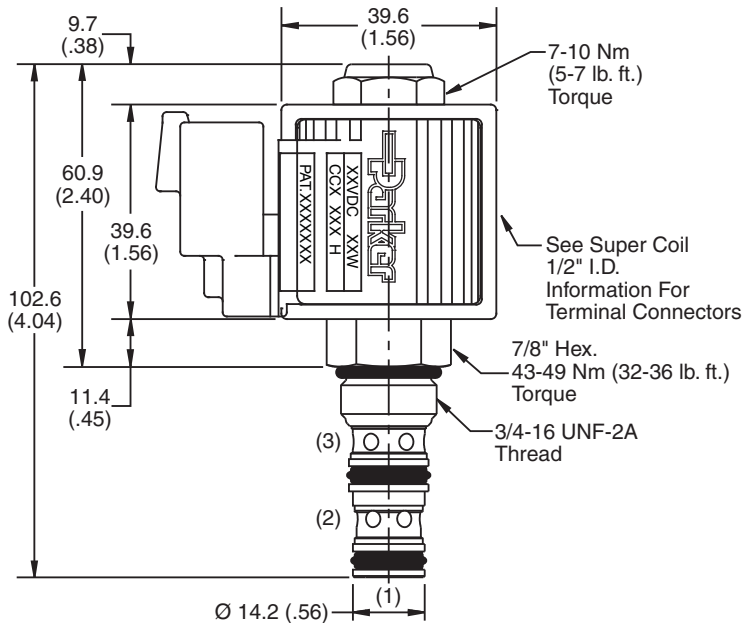

Ordering Information

DSH083		
08 Size Solenoid Valve	Style	Override Option

Highlighted represents preferred options that offer the shortest lead times. Other options may be available, but at extended lead times.

Coil(s) sold separately. Please see section CE of this catalog, 1/2" Super-Coil (CC series), for ordering information.

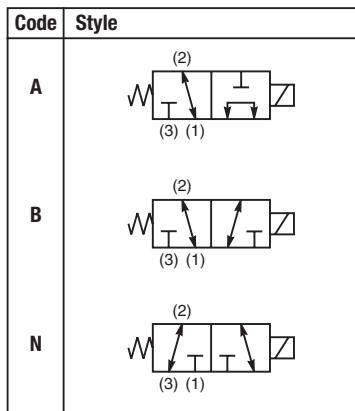

Code	Override Options
Omit	None
T	Push & Twist* (N.C. & N.O.)

*Requires Super Coil.

Code	Seals
Omit	"D"-Ring

Kit	Part Number
D-Ring Seal	SK08-3
Nitrile Seal	SK08-3
Fluorocarbon Seal	SK08-3V

Order Bodies Separately
 See section BC

B08	—	3	—	6T
08 size		3-Way Cavity		Port Size

Code	Port Size / Body Material
6T	SAE-6 / Steel (5000 PSI)

Pressure Drop vs. Flow (Through cartridge only)

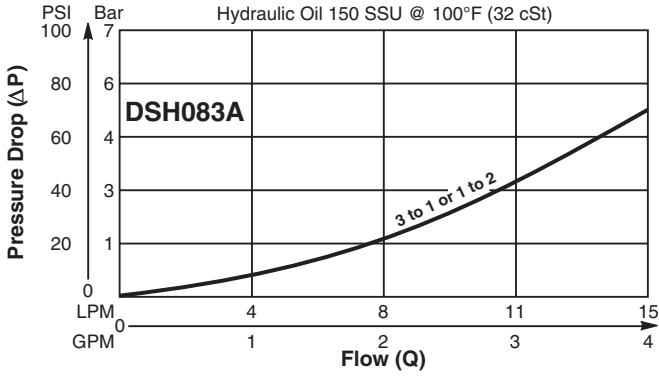

Shift Limit Characteristics (Min. Operating Voltage)

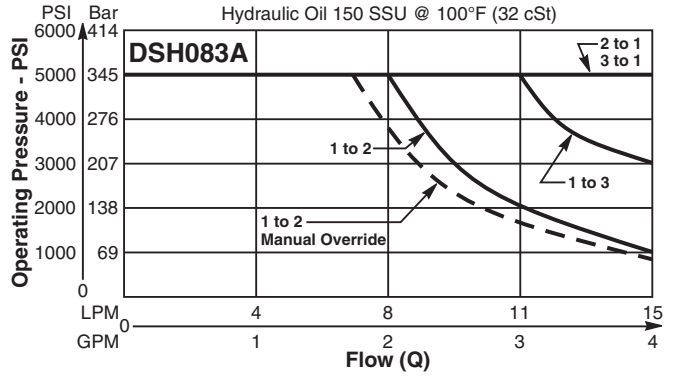

Pressure Drop vs. Flow (Through cartridge only)

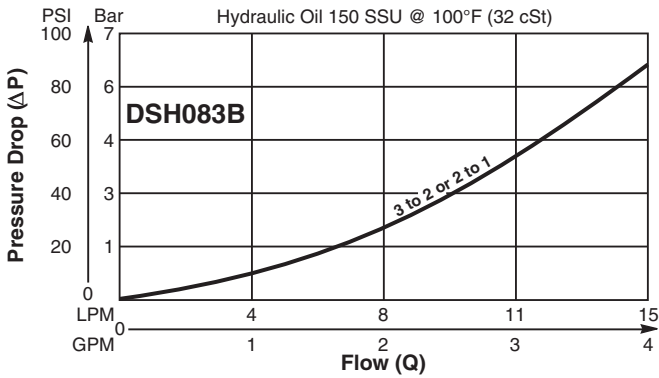

Shift Limit Characteristics (Min. Operating Voltage)

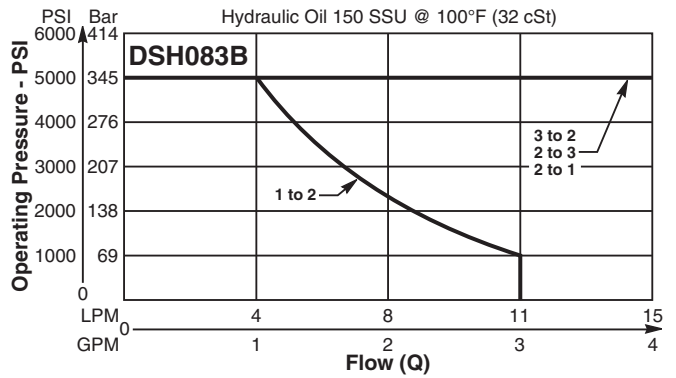

Pressure Drop vs. Flow (Through cartridge only)

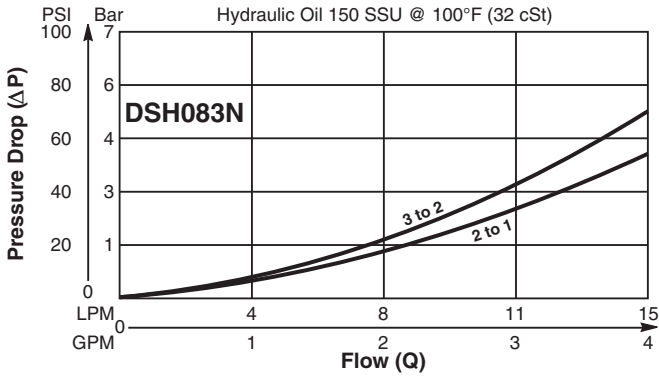

Shift Limit Characteristics (Min. Operating Voltage)

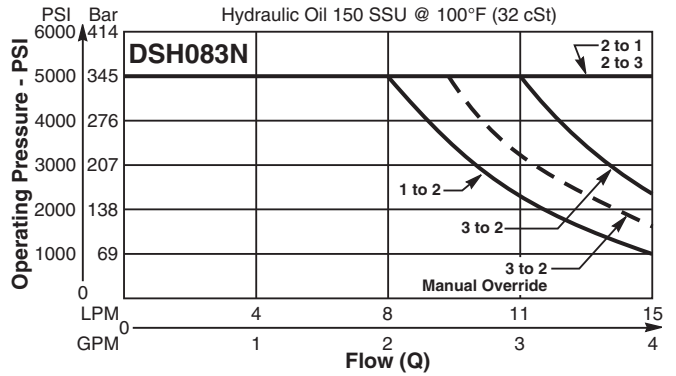

CV
Check Valves
SH
Shuttle Valves
LM
Load/Motor Controls
FC
Flow Controls
PC
Pressure Controls
LE
Logic Elements
DC
Directional Controls
SV
Solenoid Valves
PV
Proportional Valves
CE
Coils & Electronics
BC
Bodies & Cavities
TD
Technical Data

General Description

3-Way Spool Valves. For additional information see Technical Tips on pages SV2-SV6.

Features

- High flow capacity with reduced space requirements
- Standard valve bodies and common cavities
- One-piece encapsulated coil with minimal amperage draw
- Manual overrides, seal variations and other options available
- No dynamic seals
- Variety of coil terminations
- Polyurethane “D”-Ring eliminates need for backup rings
- Nylon inserted jam-nut provides secure holding in high vibration applications
- All external parts zinc plated

Specifications

Rated Flow	DSH103A	N.O.	17.0 LPM (4.5 GPM)	
		N.C.	15.0 LPM (4.0 GPM)	
		Selector	15.0 LPM (4.0 GPM)	
	DSH103B	N.C.	30.0 LPM (8.0 GPM)	
		Selector	30.0 LPM (8.0 GPM)	
	DSH103N	N.O.	15.0 LPM (4.0 GPM)	
		N.C.	15.0 LPM (4.0 GPM)	
		Selector	30.0 LPM (8.0 GPM)	
	Maximum Inlet Pressure	350 Bar (5000 PSI)		
	Leakage at 150 SSU (32 cSt)	160 cc/min. (10 in ³ /min.) DSH103B - 250 cc/min. (15 in ³ /min.) DSH103N - 250 cc/min. (15 in ³ /min.)		
	Minimum Operating Voltage	85% of rated voltage at 20°C (72°F).		
	Response Time	50 ms to 100 ms		
	Cartridge Material	All parts steel. All operating parts hardened steel.		
Operating Temp. Range/Seals	-37°C to +93°C (“D”-Ring) (-35°F to +200°F) -34°C to +121°C (Nitrile) (-30°F to +250°F) -26°C to +204°C (Fluorocarbon) (-15°F to +400°F)			
Fluid Compatibility/Viscosity	Mineral-based or synthetic with lubricating properties at viscosities of 45 to 2000 SSU (6 to 420 cSt)			
Filtration	ISO 4406 18/16/13, SAE Class 4			
Approx. Weight	.19 kg (.42 lbs.)			
Cavity	C10-3 (See BC Section for more details)			

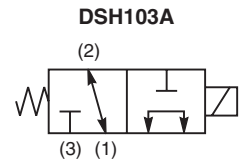

Construction/Symbols

DSH103A

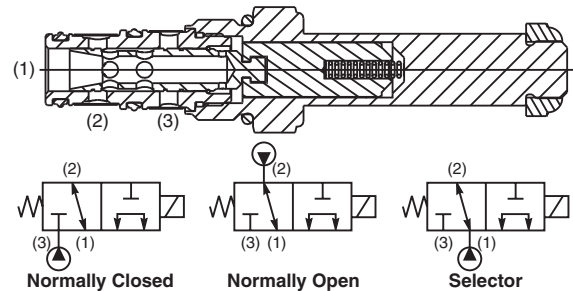

DSH103B

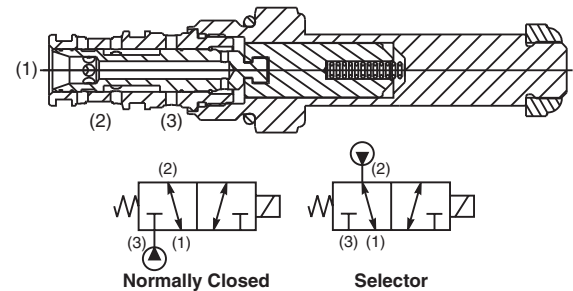

DSH103N

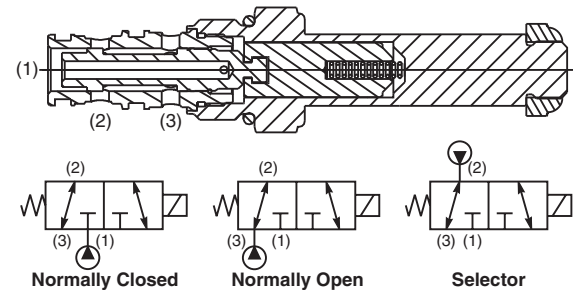

CV
Check Valves

SH
Shuttle Valves

LM
Load/Motor Controls

FC
Flow Controls

PC
Pressure Controls

LE
Logic Elements

DC
Directional Controls

SV
Solenoid Valves

PV
Proportional Valves

CE
Coils & Electronics

BC
Bodies & Cavities

TD
Technical Data

Dimensions Millimeters (Inches)

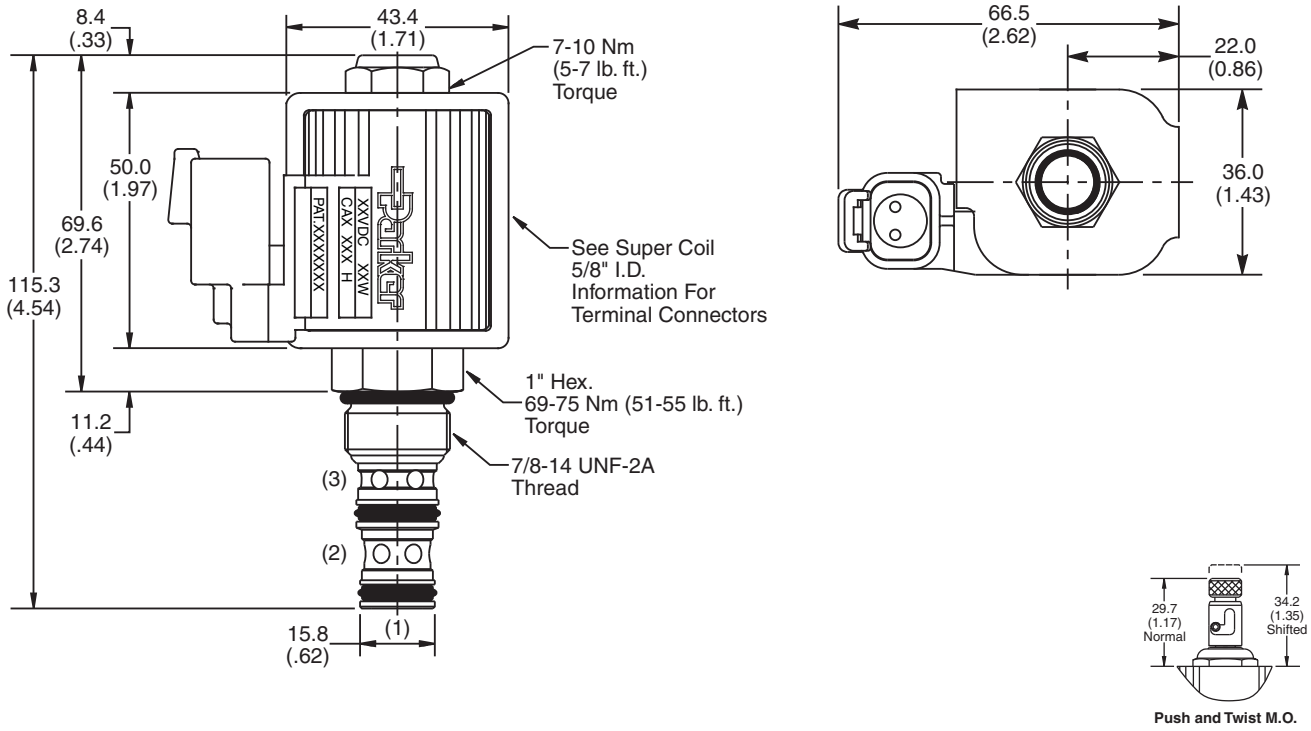

Ordering Information

DSH103		
10 Size Solenoid Valve	Style	Override Option

Highlighted represents preferred options that offer the shortest lead times. Other options may be available, but at extended lead times.

Coil(s) sold separately. Please see section CE of this catalog, 5/8" Super-Coil (CA series), for ordering information.

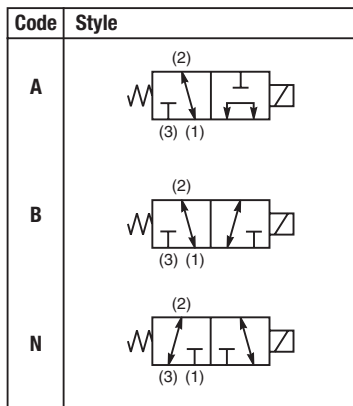

Code	Override Options
Omit	None
T	Push & Twist (N.C. & N.O.)

Code	Seals
Omit	"D"-Ring

Kit	Part Number
D-Ring Seal	SK10-3
Nitrile Seal	SK10-3
Fluorocarbon Seal	SK10-3V

Order Bodies Separately
 See section BC

B10	—	3	—	8T
10 size		3-Way Cavity		Port Size

Code	Port Size / Body Material
8T	SAE-8 / Steel (5000 PSI)



CV
Check Valves

SH
Shuttle Valves

LM
Load/Motor Controls

FC
Flow Controls

PC
Pressure Controls

LE
Logic Elements

DC
Directional Controls

SV
Solenoid Valves

PV
Proportional Valves

CE
Coils & Electronics

BC
Bodies & Cavities

TD
Technical Data

Pressure Drop vs. Flow (Through cartridge only)

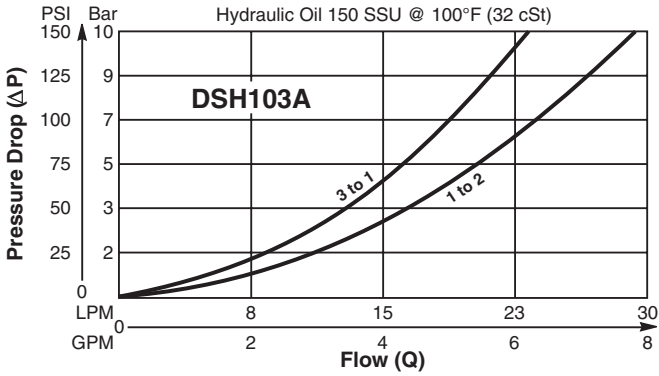

Shift Limit Characteristics (Min. Operating Voltage)

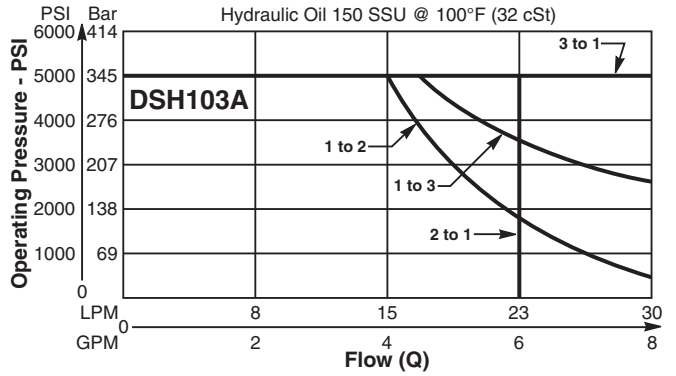

Pressure Drop vs. Flow (Through cartridge only)

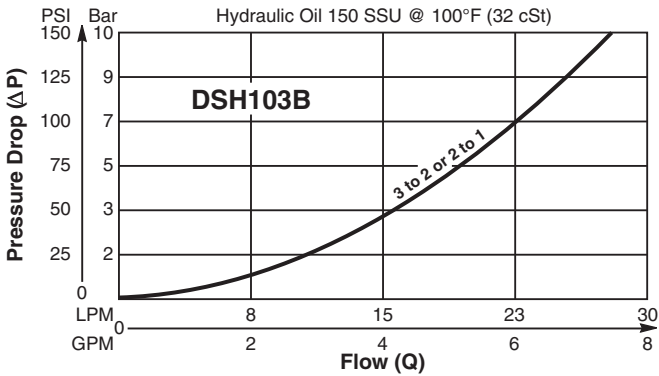

Shift Limit Characteristics (Min. Operating Voltage)

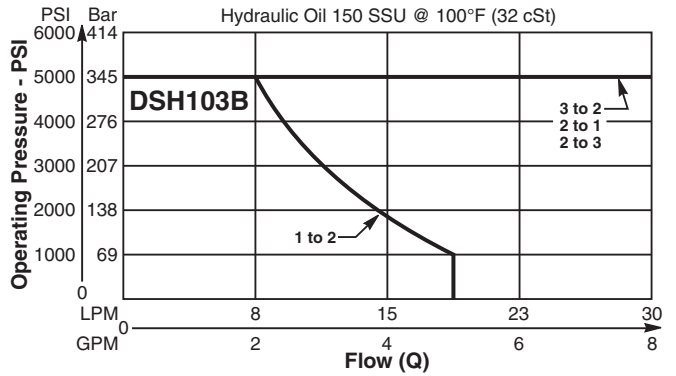

Pressure Drop vs. Flow (Through cartridge only)

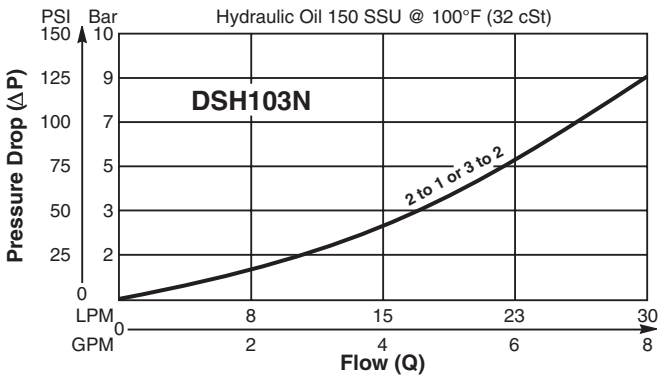

Shift Limit Characteristics (Min. Operating Voltage)

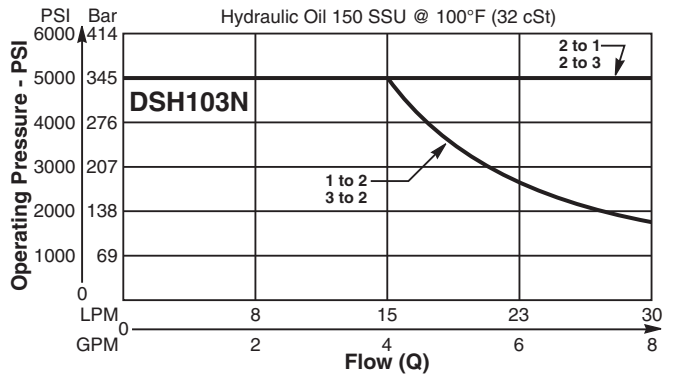

CV

Check Valves

SH

Shuttle Valves

LM

Load/Motor Controls

FC

Flow Controls

PC

Pressure Controls

LE

Logic Elements

DC

Directional Controls

SV

Solenoid Valves

PV

Proportional Valves

CE

Coils & Electronics

BC

Bodies & Cavities

TD

Technical Data

General Description

4-Way Spool Valves. For additional information see Technical Tips on pages SV2-SV6.

Features

- High flow capacity with reduced space requirements
- Standard valve bodies and common cavities
- One-piece encapsulated coil with minimal amperage draw
- Manual overrides, seal variations and other options available
- No dynamic seals
- Variety of coil terminations
- Polyurethane “D”-Ring eliminates need for backup rings
- Nylon inserted jam-nut provides secure holding in high vibration applications
- All external parts zinc plated

Specifications

Rated Flow	11-15 LPM (3-4 GPM) See Shift Limit Characteristics
Max. Inlet Pressure	350 Bar (5000 PSI)
Leakage at 150 SSU (32 cSt)	160 cc/min. (10 in ³ /min.) at 350 Bar (5000 PSI) DSH084B - 240 cc/min. (15 in ³ /min.)
Minimum Operating Voltage	85% of rated voltage at 20°C (72°F).
Response Time	Energized - 50 ms De-energized - 30 ms
Cartridge Material	All parts steel. All operating parts hardened steel.
Operating Temp. Range/Seals	-37°C to +93°C (“D”-Ring) (-35°F to +200°F) -34°C to +121°C (Nitrile) (-30°F to +250°F) -26°C to +204°C (Fluorocarbon) (-15°F to +400°F)
Fluid Compatibility/Viscosity	Mineral-based or synthetic with lubricating properties at viscosities of 45 to 2000 SSU (6 to 420 cSt)
Filtration	ISO 4406 18/16/13, SAE Class 4
Approx. Weight	.13 kg (.29 lbs.)
Cavity	C08-4 (See BC Section for more details)

Curve Selection Chart

SPOOL CODE	NEUTRAL					SHIFTED				
	4 to 1	3 to 2	2 to 1	3 to 1	3 to 4	4 to 1	3 to 2	2 to 1	3 to 1	3 to 4
B	4	3	—	—	—	—	—	2	—	4
E1	—	—	—	—	—	—	—	2	—	3
M9	—	—	3	—	1	—	—	—	4	—

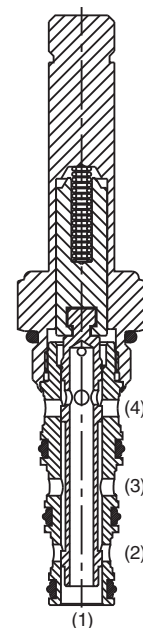
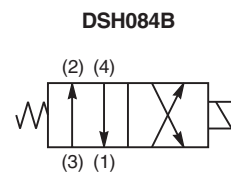

DSH084B

Performance Curves

Pressure Drop vs. Flow (Through cartridge only)

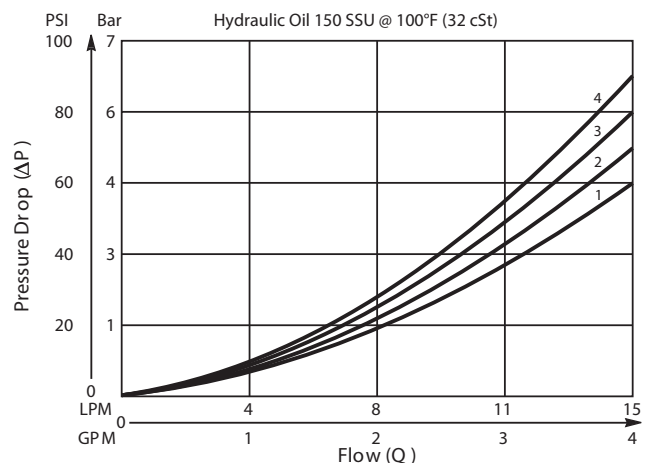

Shift Limit Characteristics (Min. Operating Voltage)

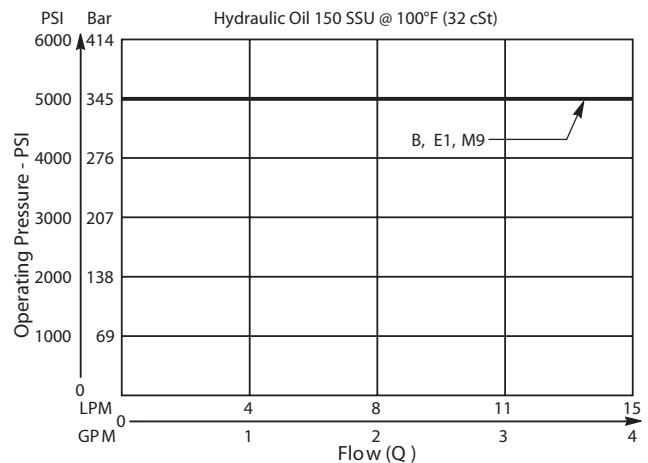

CV
Check Valves

SH
Shuttle Valves

LM
Load/Motor Controls

FC
Flow Controls

PC
Pressure Controls

LE
Logic Elements

DC
Directional Controls

SV
Solenoid Valves

PV
Proportional Valves

CE
Coils & Electronics

BC
Bodies & Cavities

TD
Technical Data

Dimensions Millimeters (Inches)

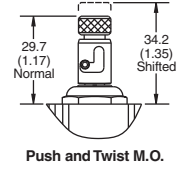
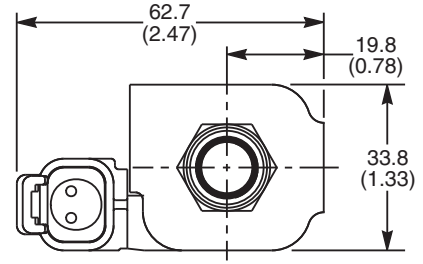
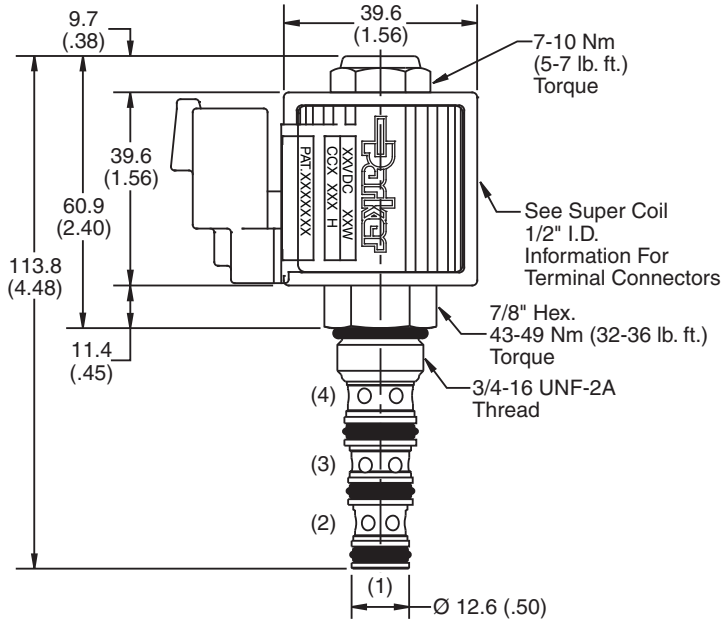

Ordering Information

DSH084

08 Size Solenoid Valve Style Override Option

Highlighted represents preferred options that offer the shortest lead times. Other options may be available, but at extended lead times.

Coil(s) sold separately. Please see section CE of this catalog, 1/2" Super-Coil (CC series), for ordering information.

Code	Style
B	
E1	
M9	

Code	Override Options
Omit	None
T	Push & Twist*

*Requires Super Coil.

Code	Seals
Omit	"D"-Ring

Kit	Part Number
D-Ring Seal	SK08-4
Nitrile Seal	SK08-4
Fluorocarbon Seal	SK08-4V

Order Bodies Separately
 See section BC

B08 - **4** - **6T**

08 size 4-Way Cavity Port Size

Code	Port Size / Body Material
6T	SAE-6 / Steel (5000 PSI)

CV
 Check Valves

SH
 Shuttle Valves

LM
 Load/Motor Controls

FC
 Flow Controls

PC
 Pressure Controls

LE
 Logic Elements

DC
 Directional Controls

SV
 Solenoid Valves

PV
 Proportional Valves

CE
 Coils & Electronics

BC
 Bodies & Cavities

TD
 Technical Data

General Description

4-Way Spool Valves. For additional information see Technical Tips on pages SV2-SV6.

Features

- High flow capacity with reduced space requirements
- Standard valve bodies and common cavities
- One-piece encapsulated coil with minimal amperage draw
- Manual overrides, seal variations and other options available
- No dynamic seals
- Variety of coil terminations
- Polyurethane “D”-Ring eliminates need for backup rings
- Nylon inserted jam-nut provides secure holding in high vibration applications
- All external parts zinc plated

Specifications

Rated Flow	25 - 38 LPM (6.5 - 10 GPM) See Shift Limit Characteristics
Maximum Inlet Pressure	350 Bar (5000 PSI)
Leakage at 150 SSU (32 cSt)	160 cc/min (10 in ³ /min) DSH104B - 320 cc/min (19.5 in ³ /min)
Minimum Operating Voltage	85% of rated voltage at 20°C (72°F).
Response Time	Energized - 30 - 60 ms De-energized - 30 - 60 ms
Cartridge Material	All parts steel. All operating parts hardened steel.
Operating Temp. Range/Seals	-37°C to +93°C (“D”-Ring) (-35°F to +200°F) -34°C to +121°C (Nitrile) (-30°F to +250°F) -26°C to +204°C (Fluorocarbon) (-15°F to +400°F)
Fluid Compatibility/ Viscosity	Mineral-based or synthetic with lubricating properties at viscosities of 45 to 2000 SSU (6 to 420 cSt)
Filtration	ISO 4406 18/16/13, SAE Class 4
Approx. Weight	.20 kg (.44 lbs.)
Cavity	C10-4 (See BC Section for more details)

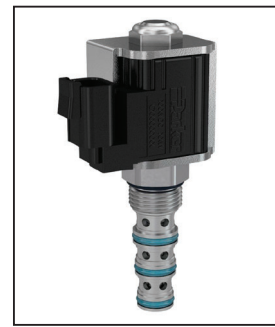

DSH104B

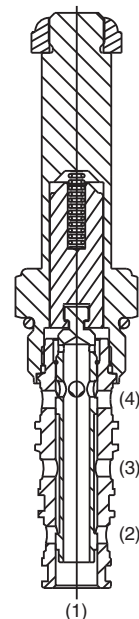
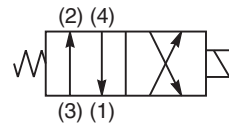

DSH104B

Performance Curves

Pressure Drop vs. Flow (Through cartridge only)

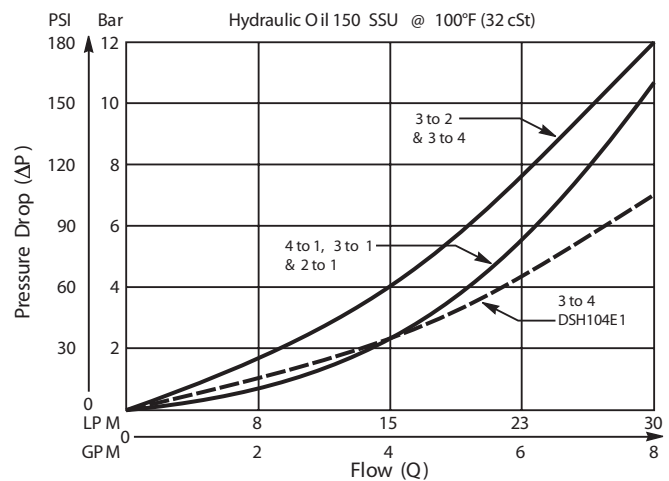

Shift Limit Characteristics (Min. Operating Voltage)

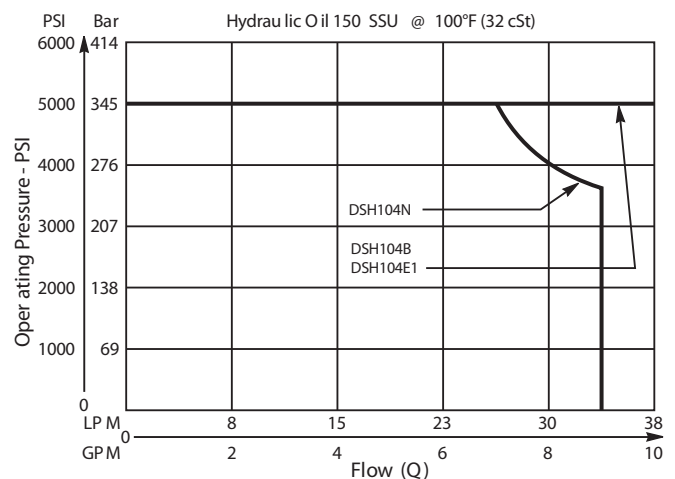

- CV
- Check Valves
- SH
- Shuttle Valves
- LM
- Load/Motor Controls
- FC
- Flow Controls
- PC
- Pressure Controls
- LE
- Logic Elements
- DC
- Directional Controls
- SV
- Solenoid Valves
- PV
- Proportional Valves
- CE
- Coils & Electronics
- BC
- Bodies & Cavities
- TD
- Technical Data

Dimensions Millimeters (Inches)

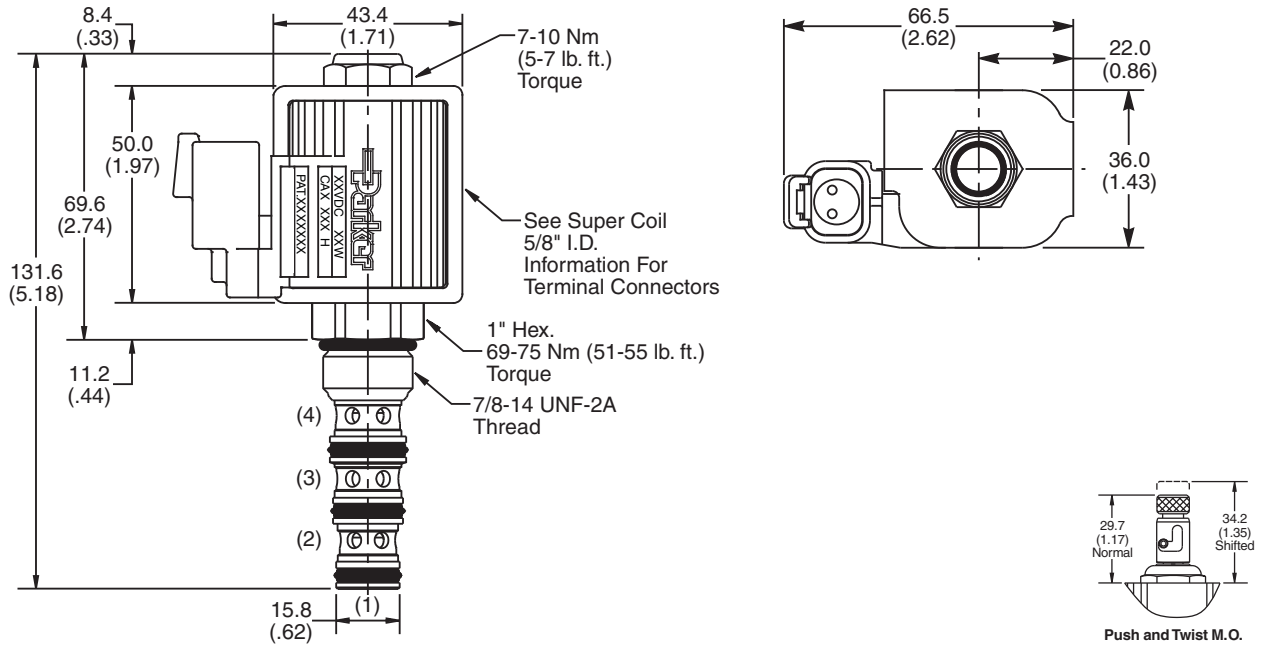

Ordering Information

DSH104

10 Size Solenoid Valve Style Override Option

Code	Style
B	
E1	
N	

Highlighted represents preferred options that offer the shortest lead times. Other options may be available, but at extended lead times.

Coil(s) sold separately. Please see section CE of this catalog, 5/8" Super-Coil (CA series), for ordering information.

Code	Override Options
Omit	None
T	Push & Twist

Code	Seals
Omit	"D"-Ring

Kit	Part Number
D-Ring Seal	SK10-4
Nitrile Seal	SK10-4
Fluorocarbon Seal	SK10-4V

Order Bodies Separately
 See section BC

B10 - **4** - **8T**

10 size 4-Way Cavity Port Size

Code	Port Size / Body Material
8T	SAE-8 / Steel (5000 PSI)



CV
Check Valves

SH
Shuttle Valves

LM
Load/Motor Controls

FC
Flow Controls

PC
Pressure Controls

LE
Logic Elements

DC
Directional Controls

SV
Solenoid Valves

PV
Proportional Valves

CE
Coils & Electronics

BC
Bodies & Cavities

TD
Technical Data

General Description

4-Way Spool Valves. For additional information see Technical Tips on pages SV2-SV6.

Features

- High flow capacity with reduced space requirements
- Standard valve bodies and common cavities
- One-piece encapsulated coil with minimal amperage draw
- Seal variations and other options available
- No dynamic seals
- Variety of coil terminations
- Nylon inserted jam-nut provides secure holding in high vibration applications
- All external parts zinc plated

Application Note

This valve is a pilot operated spool type valve. It does not require a separate pilot supply, but does require that the work port pressure or the inlet pressure is 40-60 psi higher than port 1. In an open flowing condition, with zero load and low flow, it will require a 4-6 gpm flow to create internal pilot pressure to shift. If load pressure or system pressure is 40-60 psi higher than tank, the valve will shift. Ultimately, the valve shifts based upon pressure differential from port 3 to port 1 of 40-60 psi.

Specifications

Rated Flow	113 LPM (30 GPM)
Maximum Inlet Pressure	350 Bar (5000 PSI)
Maximum Tank (port 1)	210 Bar (3000 PSI)
Leakage at 150 SSU (32 cSt)	350 cc/min (21 in ³ /min) De-Energ. 5.6 LPM (1.5 GPM) Energized Pilot Flow @ 207 Bar (3000 PSI)
Minimum Operating Voltage	85% of rated voltage at 20°C (72°F).
Response Time	Pull In - 600 ms Drop Out - 130 ms
Cartridge Material	All parts steel. All operating parts hardened steel.
Operating Temp. Range/Seals	-34°C to +121°C (Nitrile) (-30°F to +250°F) -26°C to +204°C (Fluorocarbon) (-15°F to +400°F)
Fluid Compatibility/Viscosity	Mineral-based or synthetic with lubricating properties at viscosities of 45 to 2000 SSU (6 to 420 cSt)
Filtration	ISO 4406 18/16/13, SAE Class 4
Approx. Weight	.59 kg (1.3 lbs.)
Cavity	C16-4 (See BC Section for more details)

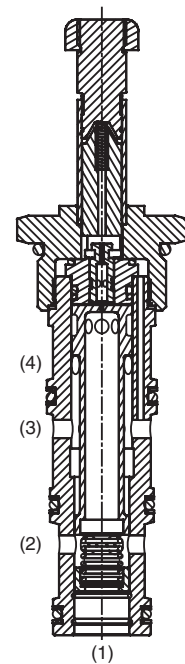
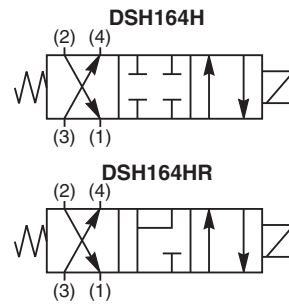
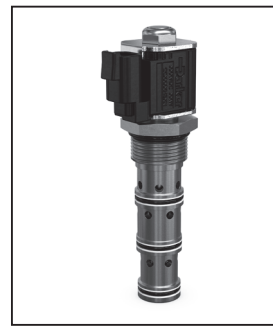

Performance Curves

Pressure Drop vs. Flow (Through cartridge only)

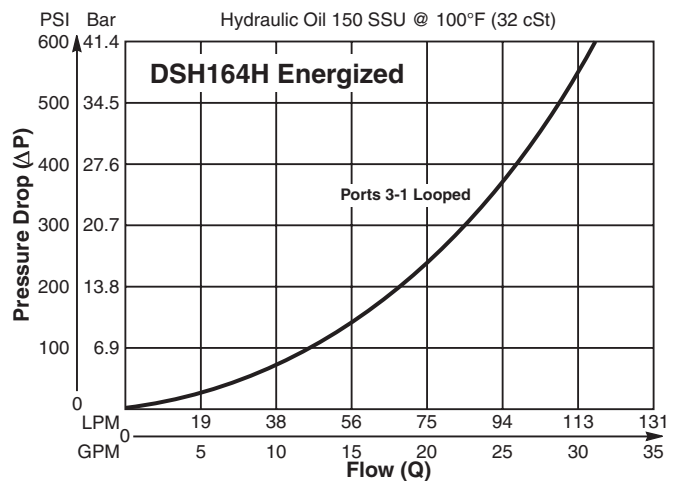

Pressure Drop vs. Flow (Through cartridge only)

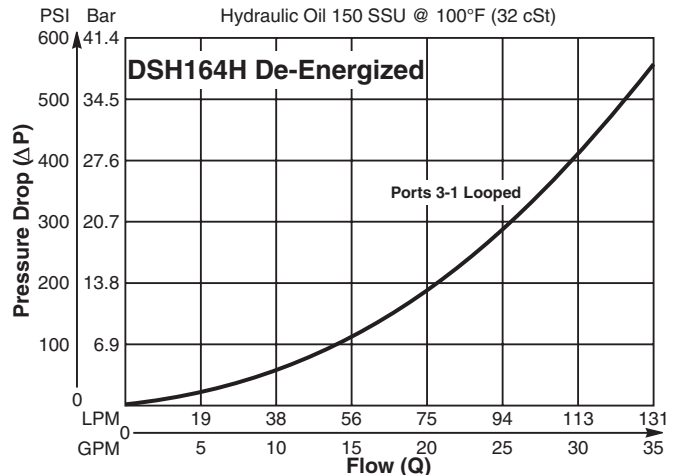

CV
Check Valves
SH
Shuttle Valves
LM
Load/Motor Controls
FC
Flow Controls
PC
Pressure Controls
LE
Logic Elements
DC
Directional Controls
SV
Solenoid Valves
PV
Proportional Valves
CE
Coils & Electronics
BC
Bodies & Cavities
TD
Technical Data

Dimensions Millimeters (Inches)

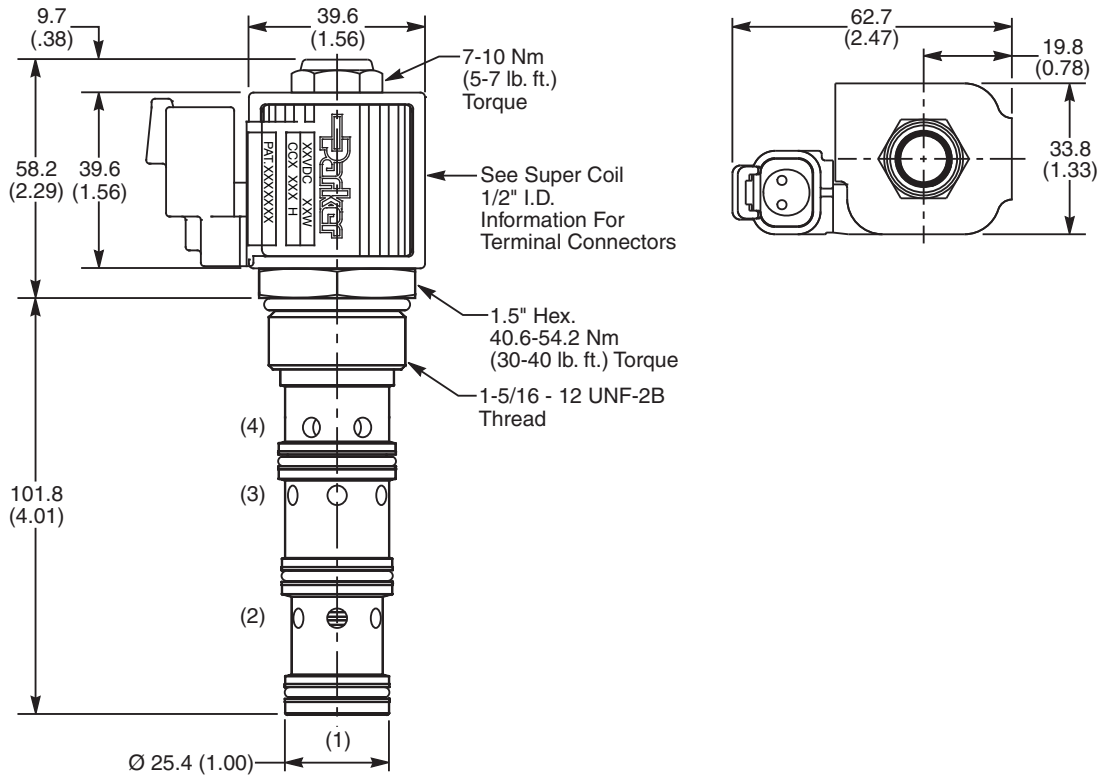

Ordering Information

DSH164
 16 Size Solenoid Valve Style

Highlighted represents preferred options that offer the shortest lead times. Other options may be available, but at extended lead times.

Coil(s) sold separately. Please see section CE of this catalog, 1/2" Super-Coil (CC series), for ordering information.

Code	Style
H	
HR	

Code	Seals
Omit	Nitrile

Kit	Part Number
Nitrile Seal	SK16-4
Fluorocarbon Seal	SK16-4V

Order Bodies Separately
 See section BC

B16 - **4** - **16T**
 16 size 4-Way Cavity Port Size

Code	Port Size / Body Material
16T	SAE-16 / Steel (5000 PSI)

CV
Check Valves

SH
Shuttle Valves

LM
Load/Motor Controls

FC
Flow Controls

PC
Pressure Controls

LE
Logic Elements

DC
Directional Controls

SV
Solenoid Valves

PV
Proportional Valves

CE
Coils & Electronics

BC
Bodies & Cavities

TD
Technical Data

General Description

4-Way, 3 Position, Closed Center Spool Valve.
 For additional information see Technical Tips on pages SV2-SV6.

Features

- Designed to operate double acting cylinders, pilot circuits and bi-directional motors, etc.
- High flow capacity with reduced space requirements
- High pressure capability to 350 Bar (5000 PSI)
- One piece cartridge housing ensures internal concentricity
- Coil: Waterproof, hermetically sealed, requires no O'Rings; Symmetrical coil can be reversed without affecting performance.
- Manual override available

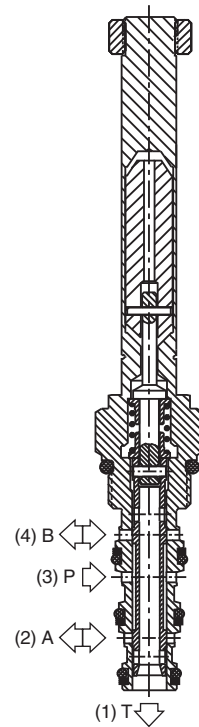
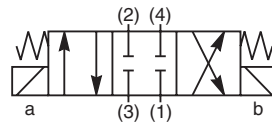

Specifications

Rated Flow	High Flow/Pressure ('SP' Coil) 17 LPM (4.5 GPM)
Maximum Inlet Pressure	'SP' Coil 350 Bar (5000 PSI)
Maximum Tank Pressure	210 Bar (3000 PSI)
Cartridge Material	All parts steel. All operating parts hardened steel.
Operating Temp. Range/Seals	-34°C to +121°C (Nitrile) (-30°F to +250°F) -26°C to +204°C (Fluorocarbon) (-15°F to +400°F)
Fluid Compatibility/Viscosity	Mineral-based or synthetic with lubricating properties at viscosities of 45 to 2000 SSU (6 to 420 cSt)
Filtration	ISO 4406 18/ 16/13, SAE Class 4
Approx. Weight	.18 kg (.40 lbs.)
Cavity	C08-4 (See BC Section for more details)

Performance Curves

Pressure Drop vs. Flow (Through cartridge only)

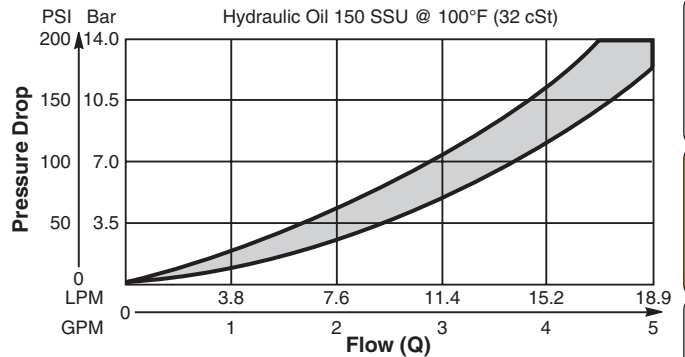

Operating Limits (Measured at 75% of Nominal Current)

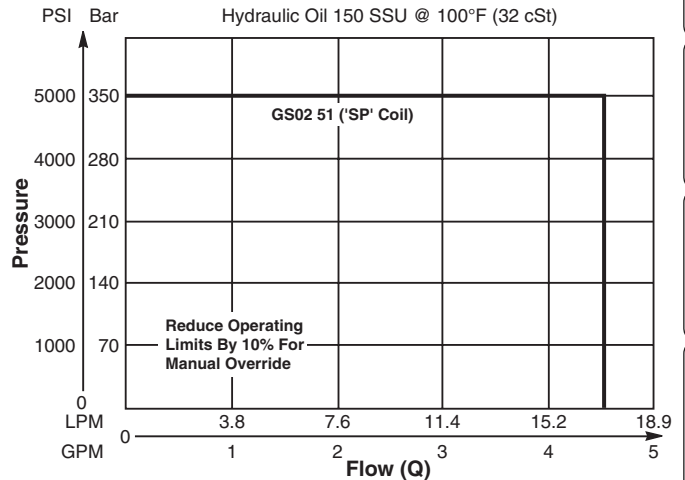

CV
Check Valves
SH
Shuttle Valves
LM
Load/Motor Controls
FC
Flow Controls
PC
Pressure Controls
LE
Logic Elements
DC
Directional Controls
SV
Solenoid Valves
PV
Proportional Valves
CE
Coils & Electronics
BC
Bodies & Cavities
TD
Technical Data

Dimensions Millimeters (Inches)

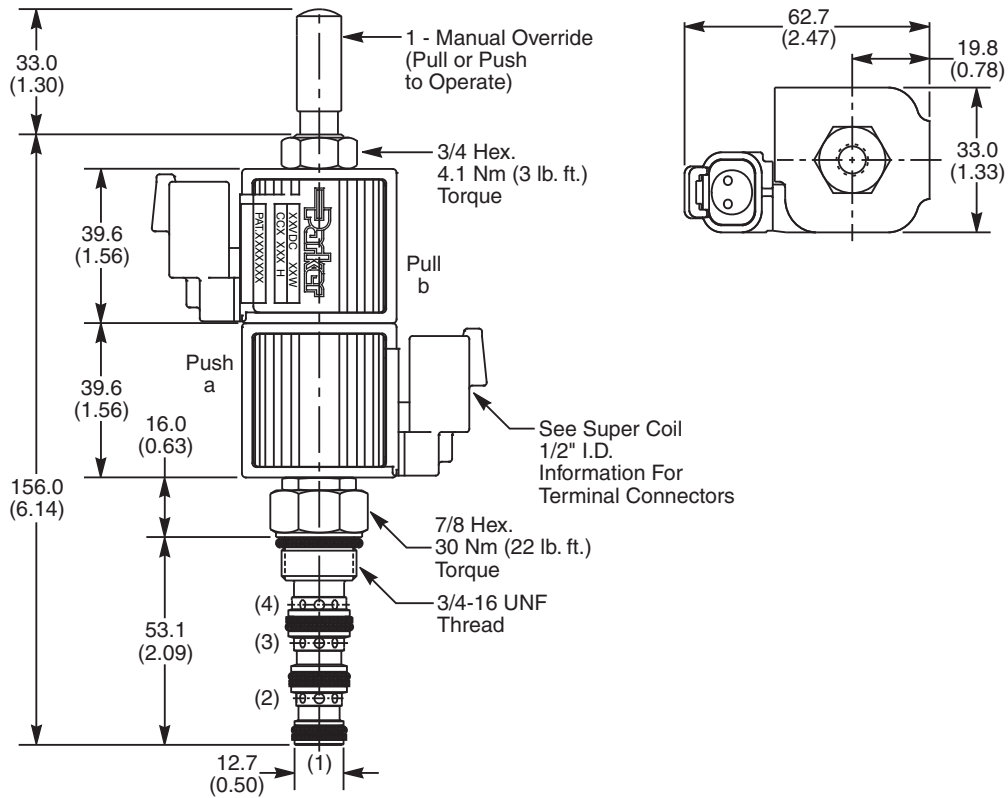

Ordering Information

GS02	51		0	N
08 Size Solenoid Valve	Style	Override Option	Screen	Seals

Highlighted represents preferred options that offer the shortest lead times. Other options may be available, but at extended lead times.

Coil(s) sold separately. Please see section CE of this catalog, 1/2" Super-Coil (CC series), for ordering information.

Code	Style
51	High Flow and Pressure ('SP' Coil)

Code	Screen
0	Not Available

Code	Override Options
0	None
1	Manual Override

Code	Seals
N	Nitrile

Order Bodies Separately
 See section BC

B08	—	4	—	6T
08 size		4-Way Cavity		Port Size

Code	Port Size / Body Material
6T	SAE-6 / Steel (5000 PSI)

Kit	Part Number
Nitrile Seal	SK30078N-1
Fluorocarbon Seal	SK30078V-1

CV
Check Valves
SH
Shuttle Valves
LM
Load/Motor Controls
FC
Flow Controls
PC
Pressure Controls
LE
Logic Elements
DC
Directional Controls
SV
Solenoid Valves
PV
Proportional Valves
CE
Coils & Electronics
BC
Bodies & Cavities
TD
Technical Data

General Description

4-Way, 3 Position, Floating Center Spool Valve.
 For additional information see Technical Tips on pages SV2-SV6.

Features

- Designed to operate double acting cylinders, pilot circuits and bi-directional motors, etc.
- High flow capacity with reduced space requirements
- High pressure capability to 350 Bar (5000 PSI)
- One piece cartridge housing ensures internal concentricity
- Coil: Waterproof, hermetically sealed, requires no O'Rings; Symmetrical coil can be reversed without affecting performance.
- Manual override available

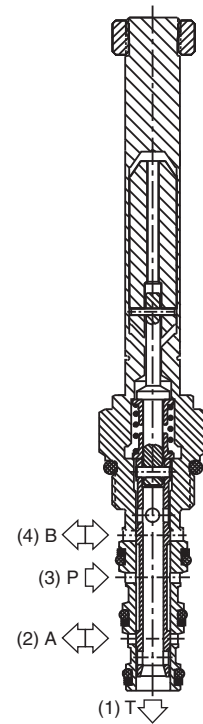
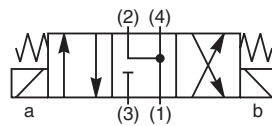
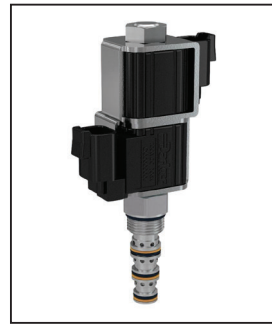

Specifications

Rated Flow	High Flow/Pressure ('SP' Coil) 15 LPM (4.0 GPM)
Maximum Inlet Pressure	'SP' Coil 350 Bar (5000 PSI)
Maximum Tank Pressure	210 Bar (3000 PSI)
Cartridge Material	All parts steel. All operating parts hardened steel.
Operating Temp. Range/Seals	-34°C to +121°C (Nitrile) (-30°F to +250°F) -26°C to +204°C (Fluorocarbon) (-15°F to +400°F)
Fluid Compatibility/Viscosity	Mineral-based or synthetic with lubricating properties at viscosities of 45 to 2000 SSU (6 to 420 cSt)
Filtration	ISO 4406 18/16/13, SAE Class 4
Approx. Weight	.18 kg (.40 lbs.)
Cavity	C08-4 (See BC Section for more details)

Performance Curves

Pressure Drop vs. Flow (Through cartridge only)

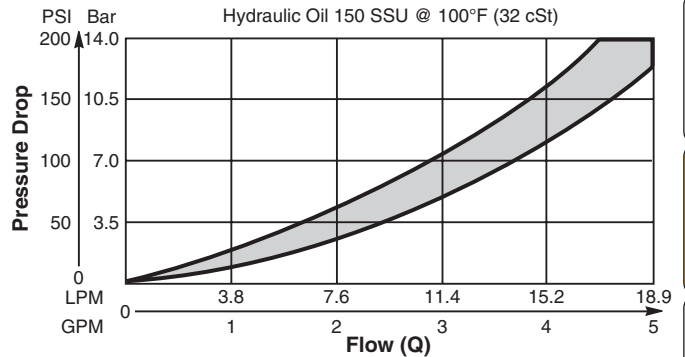

Operating Limits (Measured at 75% of Nominal Current)

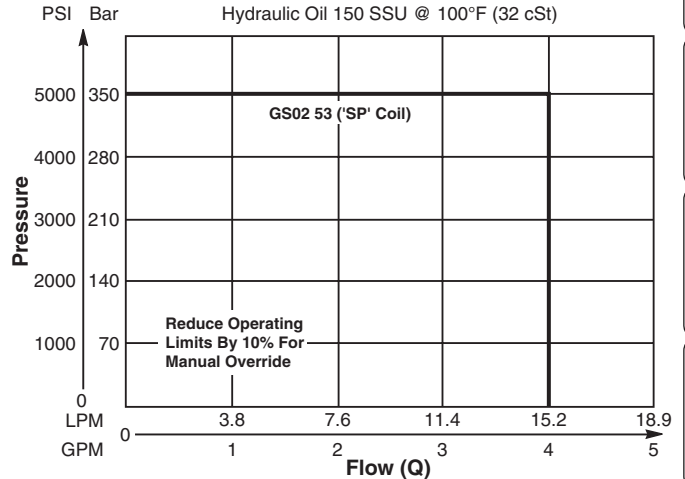

CV
Check Valves

SH
Shuttle Valves

LM
Load/Motor Controls

FC
Flow Controls

PC
Pressure Controls

LE
Logic Elements

DC
Directional Controls

SV
Solenoid Valves

PV
Proportional Valves

CE
Coils & Electronics

BC
Bodies & Cavities

TD
Technical Data

Dimensions Millimeters (Inches)

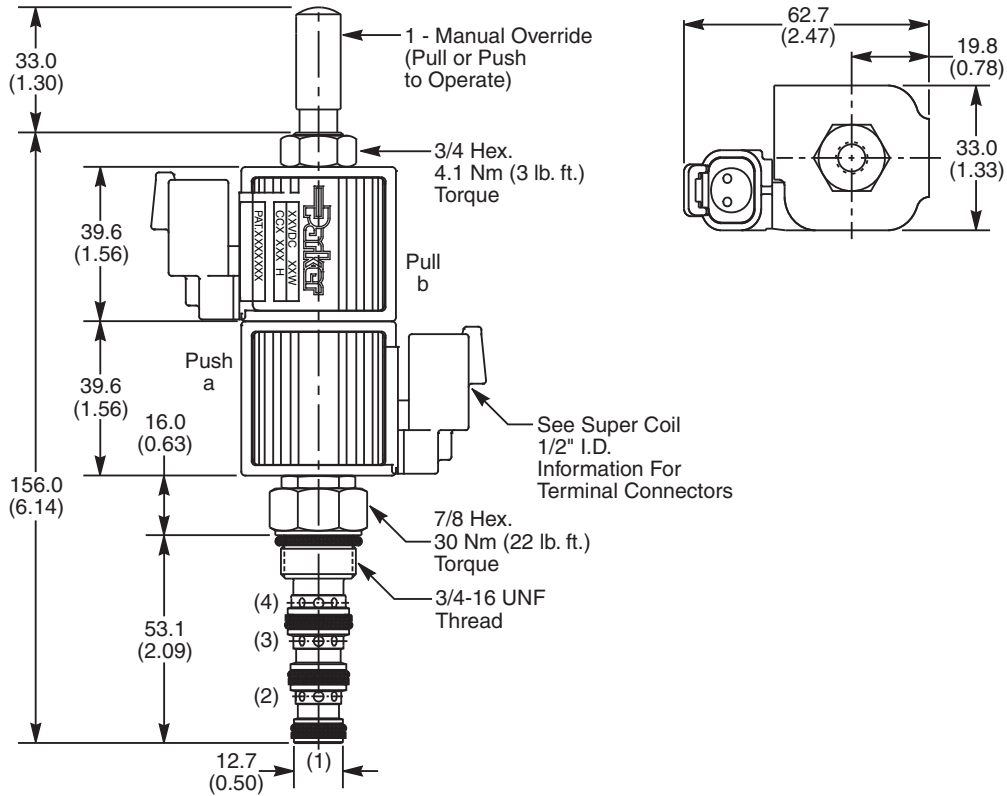

Ordering Information

GS02	53		0	N
08 Size Solenoid Valve	Style	Override Option	Screen	Seals

Highlighted represents preferred options that offer the shortest lead times. Other options may be available, but at extended lead times.

Coil(s) sold separately. Please see section CE of this catalog, 1/2" Super-Coil (CC series), for ordering information.

Code	Style
53	High Flow and Pressure ('SP' Coil)

Code	Screen
0	Not Available

Code	Override Options
0	None
1	Manual Override

Code	Seals
N	Nitrile

Order Bodies Separately
 See section BC

B08	—	4	—	6T
08 size		4-Way Cavity		Port Size

Code	Port Size / Body Material
6T	SAE-6 / Steel (5000 PSI)

Kit	Part Number
Nitrile Seal	SK30078N-1
Fluorocarbon Seal	SK30078V-1



CV
Check Valves

SH
Shuttle Valves

LM
Load/Motor Controls

FC
Flow Controls

PC
Pressure Controls

LE
Logic Elements

DC
Directional Controls

SV
Solenoid Valves

PV
Proportional Valves

CE
Coils & Electronics

BC
Bodies & Cavities

TD
Technical Data

General Description

4-Way, 3 Position, Tandem Center Spool Valve.
 For additional information see Technical Tips on pages SV2-SV6.

Features

- Designed to operate double acting cylinders, pilot circuits and bi-directional motors, etc.
- High flow capacity with reduced space requirements
- High pressure capability
- One piece cartridge housing ensures internal concentricity
- Coil: Waterproof, hermetically sealed, requires no O'Rings; Symmetrical coil can be reversed without affecting performance.
- Manual override available

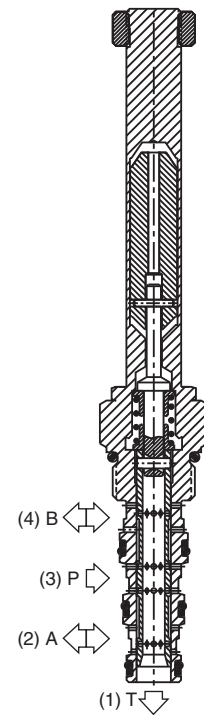
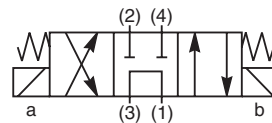

Specifications

Rated Flow	13 LPM (3.5 GPM)
Maximum Inlet Pressure	350 Bar (5000 PSI)
Maximum Tank Pressure	210 Bar (3000 PSI)
Cartridge Material	All parts steel. All operating parts hardened steel.
Operating Temp. Range/Seals	-34°C to +121°C (Nitrile) (-30°F to +250°F) -26°C to +204°C (Fluorocarbon) (-15°F to +400°F)
Fluid Compatibility/Viscosity	Mineral-based or synthetic with lubricating properties at viscosities of 45 to 2000 SSU (6 to 420 cSt)
Filtration	ISO 4406 18/16/13, SAE Class 4
Approx. Weight	.18 kg (.40 lbs.)
Cavity	C08-4 (See BC Section for more details)

Performance Curves

Pressure Drop vs. Flow (Through cartridge only)

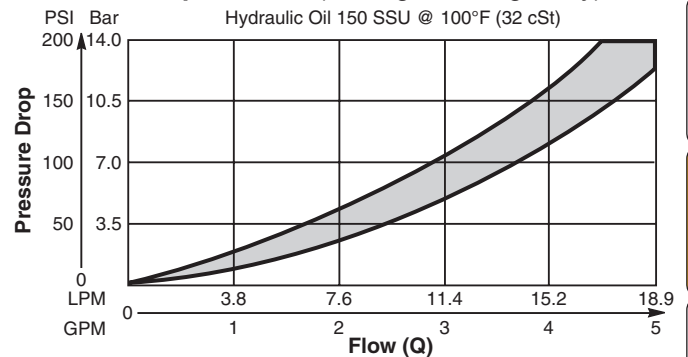

Operating Limits (Measured at 75% of Nominal Current)

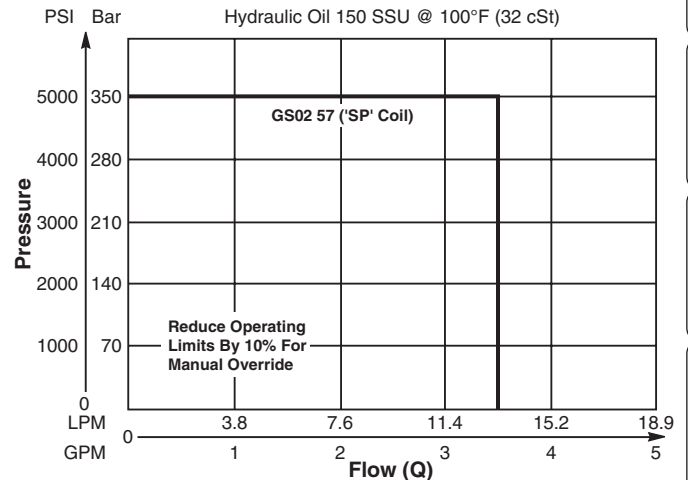

- CV Check Valves
- SH Shuttle Valves
- LM Load/Motor Controls
- FC Flow Controls
- PC Pressure Controls
- LE Logic Elements
- DC Directional Controls
- SV Solenoid Valves
- PV Proportional Valves
- CE Coils & Electronics
- BC Bodies & Cavities
- TD Technical Data

Dimensions Millimeters (Inches)

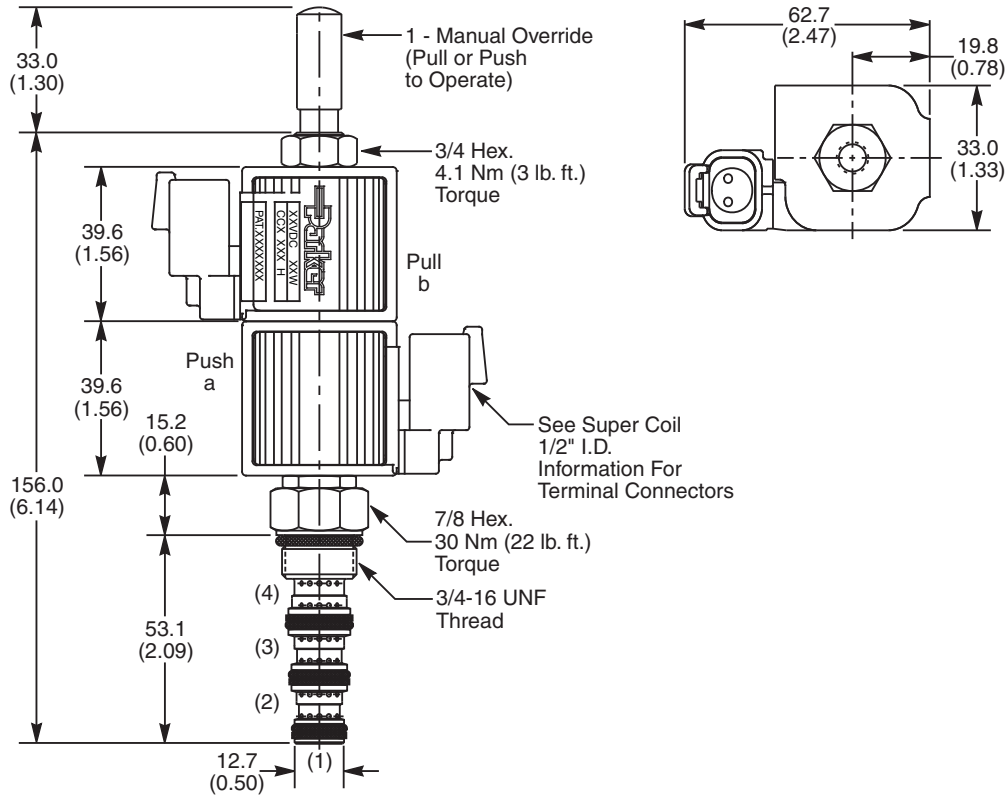

Ordering Information

GS02	57		0	N
08 Size Solenoid Valve	Style	Override Option	Screen	Seals

Highlighted represents preferred options that offer the shortest lead times. Other options may be available, but at extended lead times.

Coil(s) sold separately. Please see section CE of this catalog, 1/2" Super-Coil (CC series), for ordering information.

Code	Style
57	High Flow ('SP' Coil)

Code	Screen
0	Not Available

Code	Override Options
0	None
1	Manual Override

Code	Seals
N	Nitrile

Order Bodies Separately
 See section BC

B08	—	4	—	6T
08 size		4-Way Cavity		Port Size

Code	Port Size / Body Material
6T	SAE-6 / Steel (5000 PSI)

Kit	Part Number
Nitrile Seal	SK30078N-1
Fluorocarbon Seal	SK30078V-1

General Description

4-Way, 3 Position, Open Center Spool Valve.
 For additional information see Technical Tips on pages SV2-SV6.

Features

- Designed to operate double acting cylinders, pilot circuits and bi-directional motors, etc.
- High flow capacity with reduced space requirements
- High pressure capability
- One piece cartridge housing ensures internal concentricity
- Coil: Waterproof, hermetically sealed, requires no O'Rings; Symmetrical coil can be reversed without affecting performance.
- Manual override available

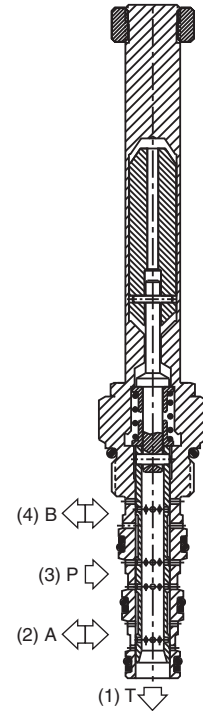
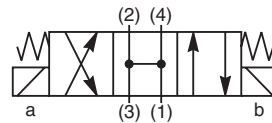
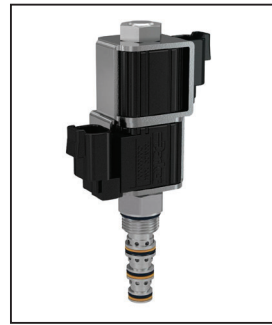

Specifications

Rated Flow	13 LPM (3.5 GPM)
Maximum Inlet Pressure	350 Bar (5000 PSI)
Maximum Tank Pressure	210 Bar (3000 PSI)
Cartridge Material	All parts steel. All operating parts hardened steel.
Operating Temp. Range/Seals	-34°C to +121°C (Nitrile) (-30°F to +250°F) -26°C to +204°C (Fluorocarbon) (-15°F to +400°F)
Fluid Compatibility/Viscosity	Mineral-based or synthetic with lubricating properties at viscosities of 45 to 2000 SSU (6 to 420 cSt)
Filtration	ISO 4406 18/16/13, SAE Class 4
Approx. Weight	.18 kg (.40 lbs.)
Cavity	C08-4 (See BC Section for more details)

Performance Curves

Pressure Drop vs. Flow (Through cartridge only)

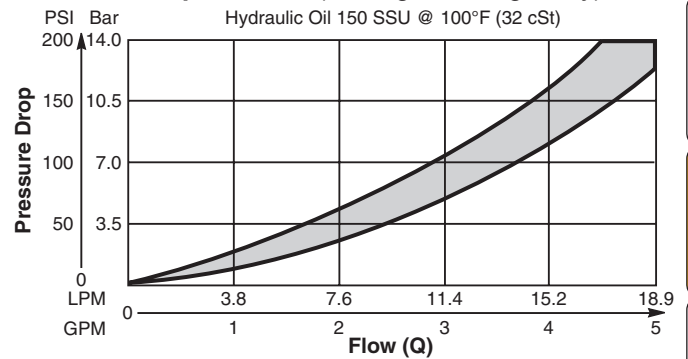

Operating Limits (Measured at 75% of Nominal Current)

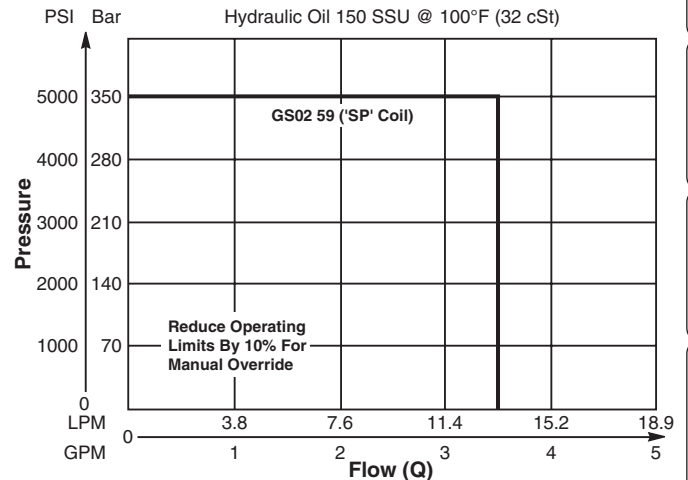

CV
Check Valves

SH
Shuttle Valves

LM
Load/Motor Controls

FC
Flow Controls

PC
Pressure Controls

LE
Logic Elements

DC
Directional Controls

SV
Solenoid Valves

PV
Proportional Valves

CE
Coils & Electronics

BC
Bodies & Cavities

TD
Technical Data

Dimensions Millimeters (Inches)

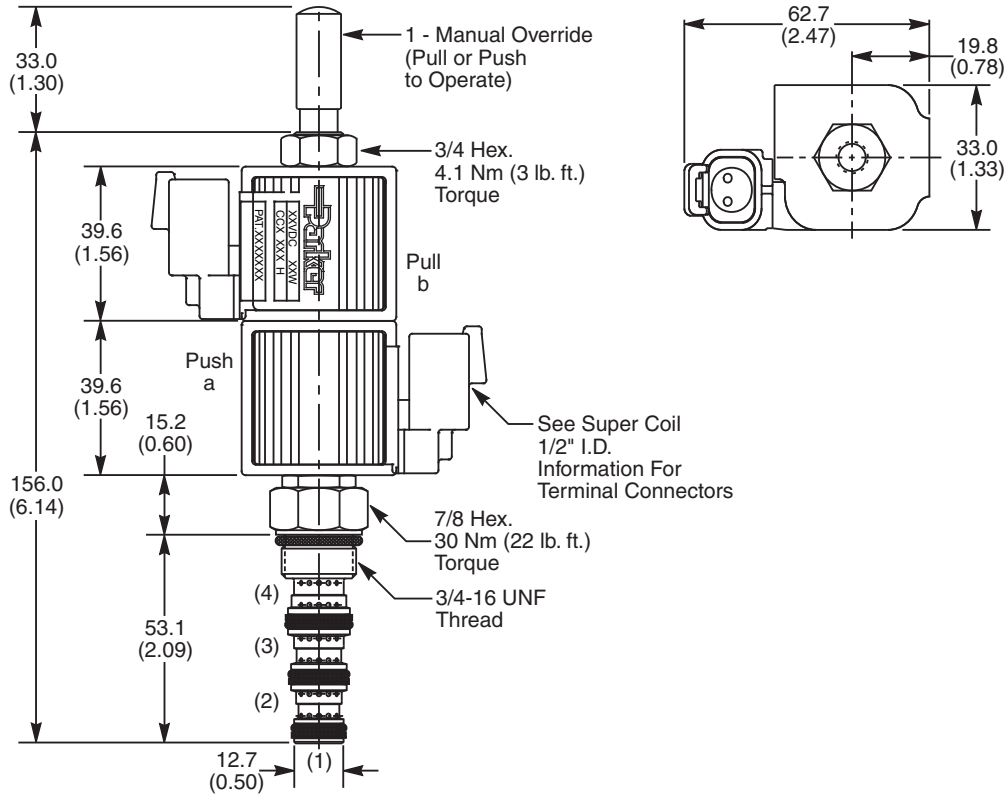

Ordering Information

GS02	59		0	N
08 Size Solenoid Valve	Style	Override Option	Screen	Seals

Highlighted represents preferred options that offer the shortest lead times. Other options may be available, but at extended lead times.

Coil(s) sold separately. Please see section CE of this catalog, 1/2" Super-Coil (CC series), for ordering information.

Code	Style
59	High Flow ('SP' Coil)

Code	Screen
0	Not Available

Code	Override Options
0	None
1	Manual Override

Code	Seals
N	Nitrile

Order Bodies Separately
 See section BC

B08	—	4	—	6T
08 size		4-Way Cavity		Port Size

Code	Port Size / Body Material
6T	SAE-6 / Steel (5000 PSI)

Kit	Part Number
Nitrile Seal	SK30078N-1
Fluorocarbon Seal	SK30078V-1

General Description

4-Way Spool Valves. For additional information see Technical Tips on pages SV2-SV6.

Features

- High flow capacity with reduced space requirements
- Standard valve bodies and common cavities
- Replaceable, one piece encapsulated coils with minimal amperage draw
- Manual overrides, seal variations and other options available
- Oil immersed armature solenoid, no dynamic seals
- Variety of coil terminations and voltages
- Polyurethane "D"-Ring

Specifications

Rated Flow	C2, C9 19 LPM (5 GPM) C1, C4 26 LPM (7 GPM)
Maximum Inlet Pressure	250 Bar (3600 PSI)
Leakage at 150 SSU (32 cSt)	160 cc/min. (10 in ³ /min.)
Minimum Operating Voltage	85% of rated voltage at 20°C (72°F).
Response Time	40 - 150 ms
Cartridge Material	All parts steel. All operating parts hardened steel.
Operating Temp. Range/Seals	-37°C to +93°C ("D"-Ring) (-35°F to +200°F) -34°C to +121°C (Nitrile) (-30°F to +250°F) -26°C to +204°C (Fluorocarbon) (-15°F to +400°F)
Fluid Compatibility/Viscosity	Mineral-based or synthetic with lubricating properties at viscosities of 45 to 2000 SSU (6 to 420 cSt)
Filtration	ISO 4406 18/16/13, SAE Class 4
Approx. Weight	.29 kg (.64 lbs.)
Cavity	C10-4

Curve Selection Chart

SPOOL CODE	SPOOL SHIFTED				SPOOL CENTERED		
	3 to 2	3 to 4	2 to 1	4 to 1	3 to 1	2 to 1	4 to 1
C1	2	2	4	4	—	—	—
C2	1	1	2	2	5	4	3
C4	2	2	5	5	—	4	4
C9	1	1	2	2	5	—	—



DSL105C1

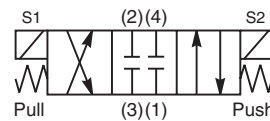

DSL105C1

Performance Curves

Pressure Drop vs. Flow (Through cartridge only)

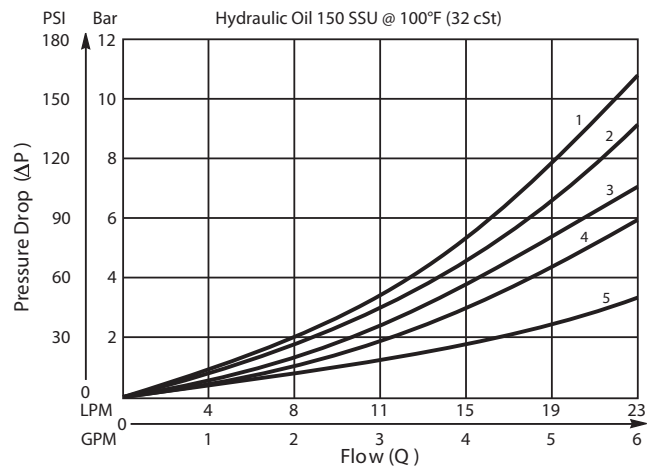

Shift Limit Characteristics (Min. Operating Voltage)

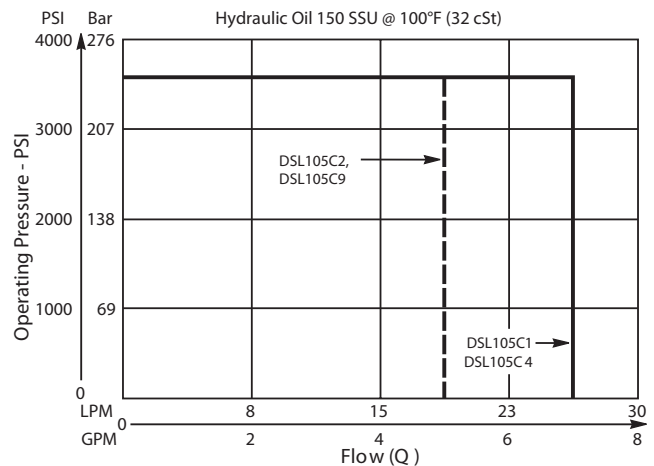

- CV
- Check Valves
- SH
- Shuttle Valves
- LM
- Load/Motor Controls
- FC
- Flow Controls
- PC
- Pressure Controls
- LE
- Logic Elements
- DC
- Directional Controls
- SV
- Solenoid Valves
- PV
- Proportional Valves
- CE
- Coils & Electronics
- BC
- Bodies & Cavities
- TD
- Technical Data

Dimensions Millimeters (Inches)

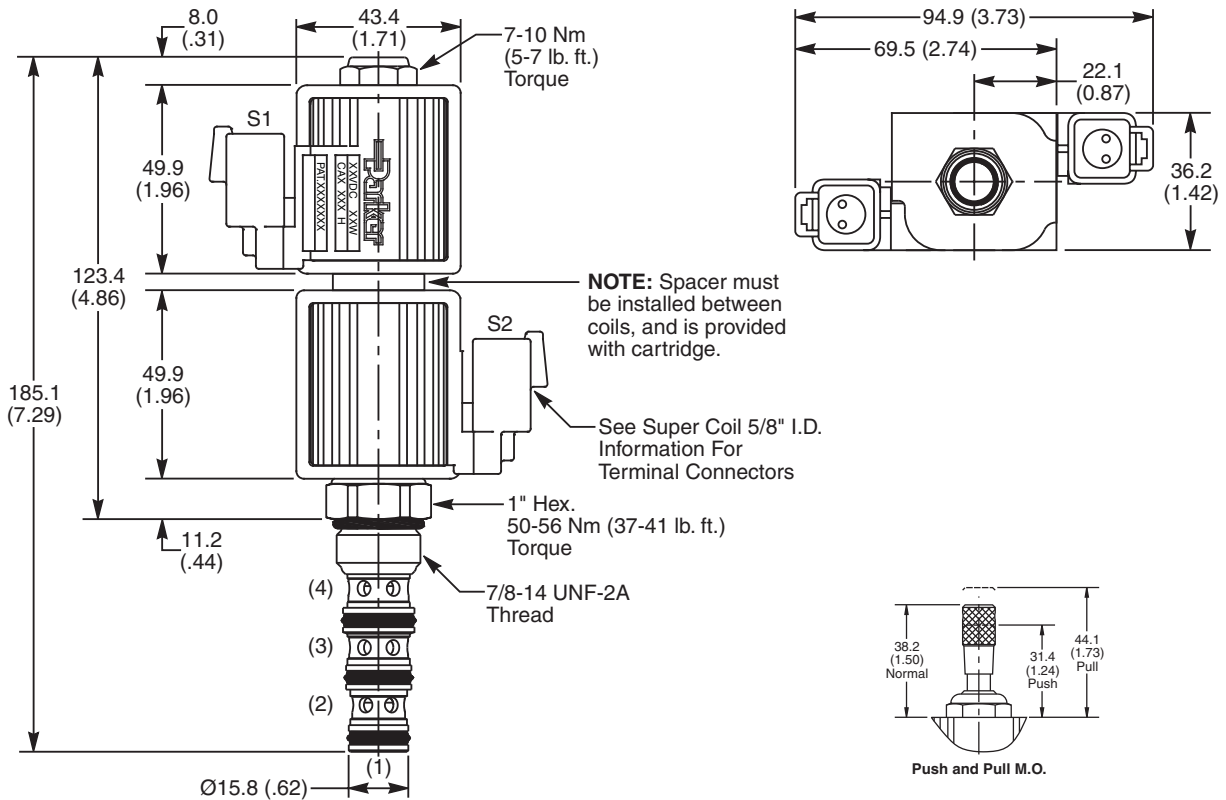

Ordering Information

DSL105		
10 Size Solenoid Valve	Style	Override Option

Highlighted represents preferred options that offer the shortest lead times. Other options may be available, but at extended lead times.

Coil(s) sold separately. Please see section CE of this catalog, 5/8" Super-Coil (CA series), for ordering information.

Code	Style
C1	
C2	
C4	
C9	

Code	Override Options
Omit	None

Code	Seals
Omit	"D"-Ring

Kit	Part Number
D-Ring Seal	SK10-4
Nitrile Seal	SK10-4
Fluorocarbon Seal	SK10-4V

Order Bodies Separately
 See section BC

B10	4	8T
10 size	4-Way Cavity	Port Size

Code	Port Size / Body Material
8T	SAE-8 / Steel (5000 PSI)

CV
Check Valves
SH
Shuttle Valves
LM
Load/Motor Controls
FC
Flow Controls
PC
Pressure Controls
LE
Logic Elements
DC
Directional Controls
SV
Solenoid Valves
PV
Proportional Valves
CE
Coils & Electronics
BC
Bodies & Cavities
TD
Technical Data

General Description

4-Way, 3 Position, Closed Center Spool Valve.
 For additional information see Technical Tips on pages SV2-SV6.

Features

- Four way closed center valve designed to operate double acting cylinders and bi-directional motors, etc.
- One piece cartridge housing ensures internal concentricity
- Coil: Waterproof, hermetically sealed, requires no O’Rings; Symmetrical coil can be reversed without affecting performance.

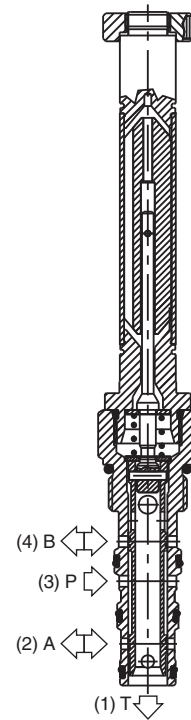
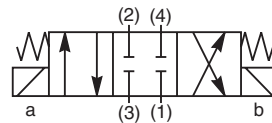

Specifications

Rated Flow	42 LPM (11 GPM)
Maximum Inlet Pressure	350 Bar (5000 PSI)
Maximum Tank Pressure	210 Bar (3000 PSI)
Leakage at 150 SSU (32 cSt)	160 cc/min @ 210 Bar (3000 PSI)
Minimum Operating Voltage	85% of rated voltage at 20°C (72°F).
Response Time	Open 30-60 ms Close 20-40 ms
Cartridge Material	All parts steel. All operating parts hardened steel.
Operating Temp. Range/Seals	-34°C to +121°C (Nitrile) (-30°F to +250°F) -26°C to +204°C (Fluorocarbon) (-15°F to +400°F)
Fluid Compatibility/Viscosity	Mineral-based or synthetic with lubricating properties at viscosities of 45 to 2000 SSU (6 to 420 cSt)
Filtration	ISO 4406 18/16/13, SAE Class 4
Approx. Weight	.26 kg (.58 lbs.)
Cavity	C10-4 (See BC Section for more details)

Performance Curves

Pressure Drop vs. Flow Energized - GS045250ND
 (Through cartridge only)

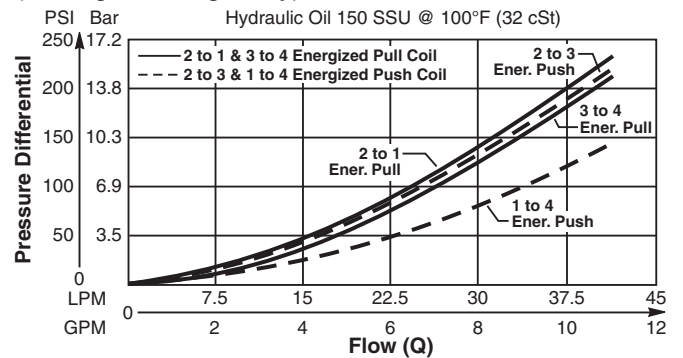

Operating Limits (Measured at 75% of Nominal Current)

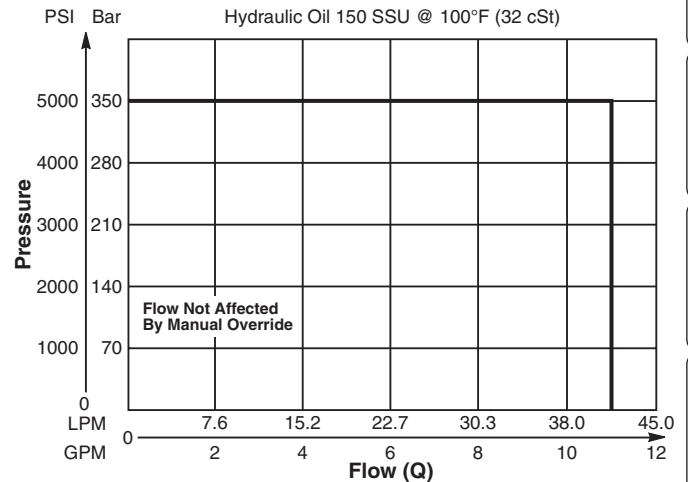

CV
Check Valves

SH
Shuttle Valves

LM
Load/Motor Controls

FC
Flow Controls

PC
Pressure Controls

LE
Logic Elements

DC
Directional Controls

SV
Solenoid Valves

PV
Proportional Valves

CE
Coils & Electronics

BC
Bodies & Cavities

TD
Technical Data

Dimensions Millimeters (Inches)

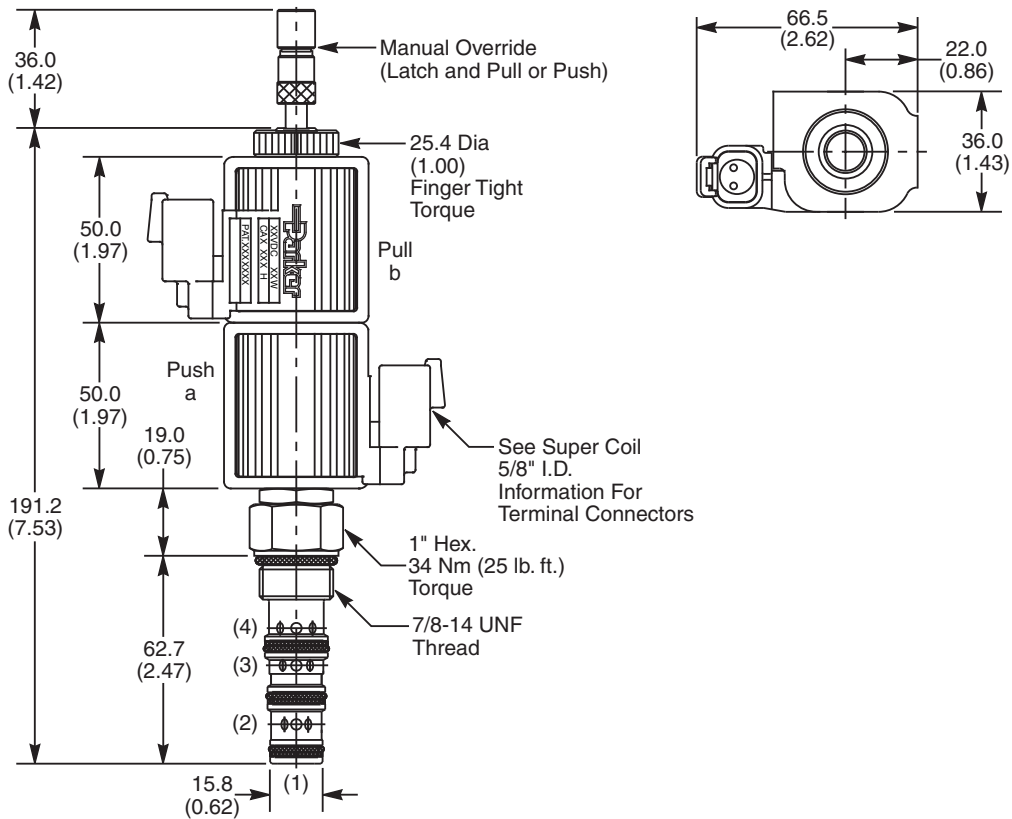

Ordering Information

GS04	52		0	N	D
10 Size Solenoid Valve	Style	Override Option	Screen	Seals	Design Level

Highlighted represents preferred options that offer the shortest lead times. Other options may be available, but at extended lead times.

Coil(s) sold separately. Please see section CE of this catalog, 5/8" Super-Coil (CA series), for ordering information.

Order Bodies Separately
 See section BC

Code	Style
52	High Flow and Pressure ('SP' Coil)

Code	Screen
0	None (Contact factory for OEM requirements)

B10	—	4	—	8T
10 size		4-Way Cavity		Port Size

Code	Override Options
0	None
5	Standard - Center Detent only, Latch Operated, Push and Pull (*40 nt/9 lbs.)

Code	Seals
N	Nitrile

Code	Port Size / Body Material
8T	SAE-8 / Steel (5000 PSI)

Code	Design Level
D	Industry Common Cavity

*Force to push at 210 Bar (3000 PSI).
 Less to Pull.

Kit	Part Number
Nitrile Seal	SK30506N-1
Fluorocarbon Seal	SK30506V-1



CV
Check Valves
SH
Shuttle Valves
LM
Load/Motor Controls
FC
Flow Controls
PC
Pressure Controls
LE
Logic Elements
DC
Directional Controls
SV
Solenoid Valves
PV
Proportional Valves
CE
Coils & Electronics
BC
Bodies & Cavities
TD
Technical Data

General Description

4-Way, 3 Position, Floating Center Spool Valve.
 For additional information see Technical Tips on pages SV2-SV6.

Features

- Four way floating center valve designed to operate double acting cylinders and bi-directional motors, etc.
- One piece cartridge housing ensures internal concentricity
- Coil: Waterproof, hermetically sealed, requires no O’Rings; Symmetrical coil can be reversed without affecting performance.

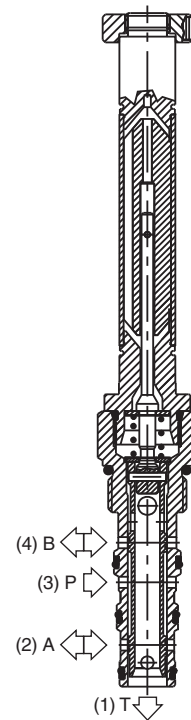
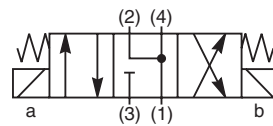
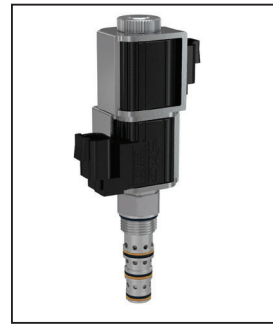

Specifications

Rated Flow	42 LPM (11 GPM)
Maximum Inlet Pressure	350 Bar (5000 PSI)
Maximum Tank Pressure	210 Bar (3000 PSI)
Leakage at 150 SSU (32 cSt)	160 cc/min @ 210 Bar (3000 PSI)
Minimum Operating Voltage	85% of rated voltage at 20°C (72°F).
Response Time	Open 30-60 ms Close 20-40 ms
Cartridge Material	All parts steel. All operating parts hardened steel.
Operating Temp. Range/Seals	-34°C to +121°C (Nitrile) (-30°F to +250°F) -26°C to +204°C (Fluorocarbon) (-15°F to +400°F)
Fluid Compatibility/Viscosity	Mineral-based or synthetic with lubricating properties at viscosities of 45 to 2000 SSU (6 to 420 cSt)
Filtration	ISO 4406 18/16/13, SAE Class 4
Approx. Weight	.26 kg (.58 lbs.)
Cavity	C10-4 (See BC Section for more details)

Performance Curves

Pressure Drop vs. Flow Energized - GS045450ND
 (Through cartridge only)

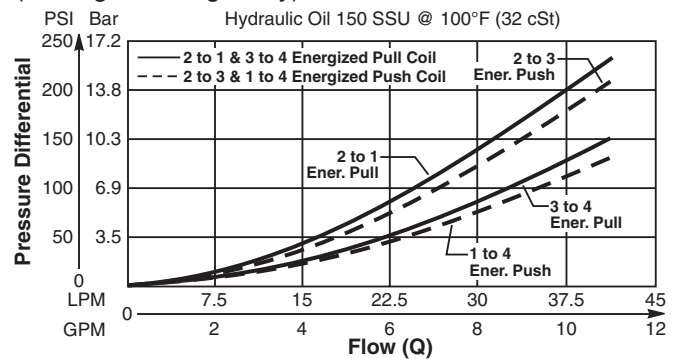

Operating Limits (Measured at 75% of Nominal Current)

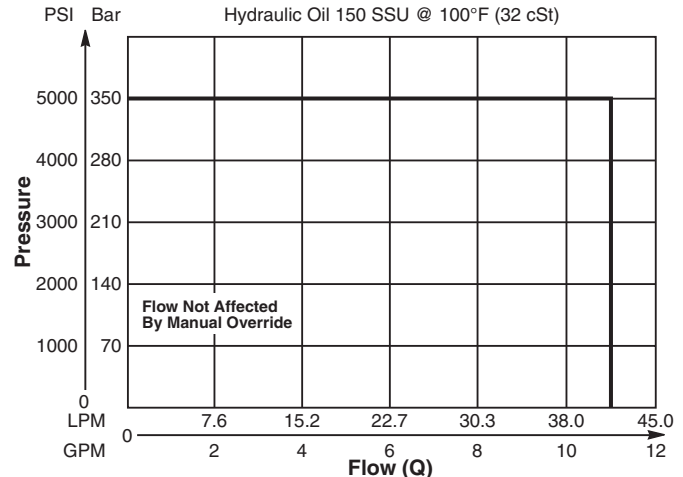

- CV Check Valves
- SH Shuttle Valves
- LM Load/Motor Controls
- FC Flow Controls
- PC Pressure Controls
- LE Logic Elements
- DC Directional Controls
- SV Solenoid Valves
- PV Proportional Valves
- CE Coils & Electronics
- BC Bodies & Cavities
- TD Technical Data

Dimensions Millimeters (Inches)

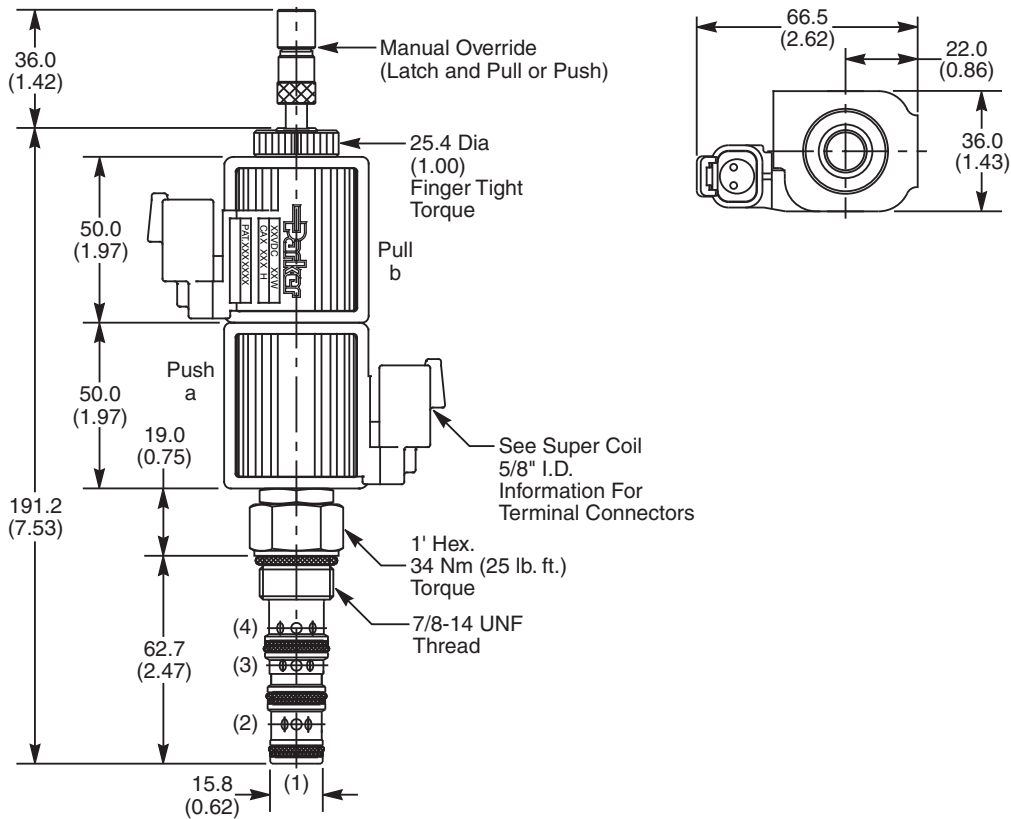

Ordering Information

GS04	54		0	N	D
10 Size Solenoid Valve	Style	Override Option	Screen	Seals	Design Level

Highlighted represents preferred options that offer the shortest lead times. Other options may be available, but at extended lead times.

Coil(s) sold separately. Please see section CE of this catalog, 5/8" Super-Coil (CA series), for ordering information.

Order Bodies Separately
 See section BC

Code	Style
54	High Flow and Pressure ('SP' Coil)

Code	Screen
0	None (Contact factory for OEM requirements)

B10	—	4	—	8T
10 size		4-Way Cavity		Port Size

Code	Override Options
0	None
5	Standard - Center Detent only, Latch Operated, Push and Pull (*40 nt/9 lbs.)

Code	Seals
N	Nitrile

Code	Port Size / Body Material
8T	SAE-8 / Steel (5000 PSI)

Code	Design Level
D	Industry Common Cavity

*Force to push at 210 Bar (3000 PSI).
 Less to Pull.

Kit	Part Number
Nitrile Seal	SK30506N-1
Fluorocarbon Seal	SK30506V-1



CV
Check Valves
SH
Shuttle Valves
LM
Load/Motor Controls
FC
Flow Controls
PC
Pressure Controls
LE
Logic Elements
DC
Directional Controls
SV
Solenoid Valves
PV
Proportional Valves
CE
Coils & Electronics
BC
Bodies & Cavities
TD
Technical Data

General Description

4-Way, 3 Position, Tandem Center Spool Valve.
 For additional information see Technical Tips on pages SV2-SV6.

Features

- Four way tandem center valve designed to operate double acting cylinders and bi-directional motors, etc.
- One piece cartridge housing ensures internal concentricity
- Coil: Waterproof, hermetically sealed, requires no O’Rings; Symmetrical coil can be reversed without affecting performance.

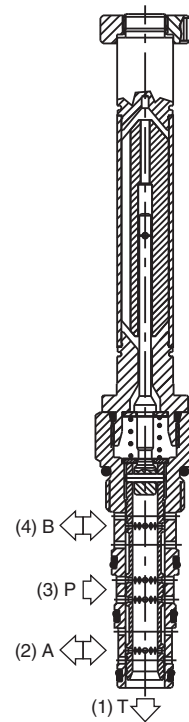
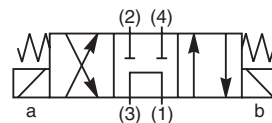
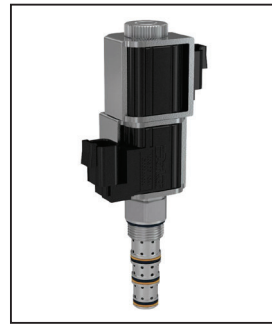

Specifications

Rated Flow	42 LPM (11 GPM)
Maximum Inlet Pressure	350 Bar (5000 PSI)
Maximum Tank Pressure	210 Bar (3000 PSI)
Leakage at 150 SSU (32 cSt)	160 cc/min @ 210 Bar (3000 PSI)
Minimum Operating Voltage	85% of rated voltage at 20°C (72°F).
Response Time	Open 30-60 ms Close 20-40 ms
Cartridge Material	All parts steel. All operating parts hardened steel.
Operating Temp. Range/Seals	-34°C to +121°C (Nitrile) (-30°F to +250°F) -26°C to +204°C (Fluorocarbon) (-15°F to +400°F)
Fluid Compatibility/Viscosity	Mineral-based or synthetic with lubricating properties at viscosities of 45 to 2000 SSU (6 to 420 cSt)
Filtration	ISO 4406 18/16/13, SAE Class 4
Approx. Weight	.26 kg (.58 lbs.)
Cavity	C10-4 (See BC Section for more details)

Performance Curves

Pressure Drop vs. Flow (Through cartridge only)

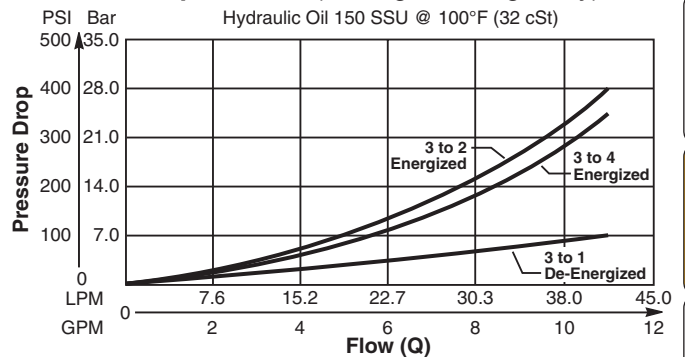

Operating Limits (Measured at 75% of Nominal Current)

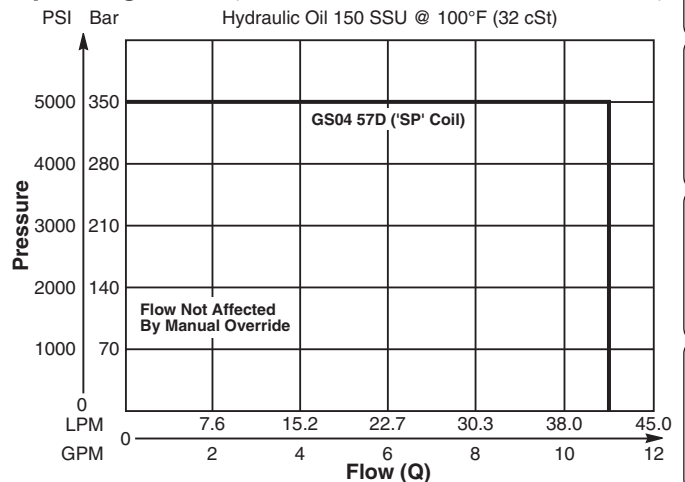

CV
Check Valves
SH
Shuttle Valves
LM
Load/Motor Controls
FC
Flow Controls
PC
Pressure Controls
LE
Logic Elements
DC
Directional Controls
SV
Solenoid Valves
PV
Proportional Valves
CE
Coils & Electronics
BC
Bodies & Cavities
TD
Technical Data

Dimensions Millimeters (Inches)

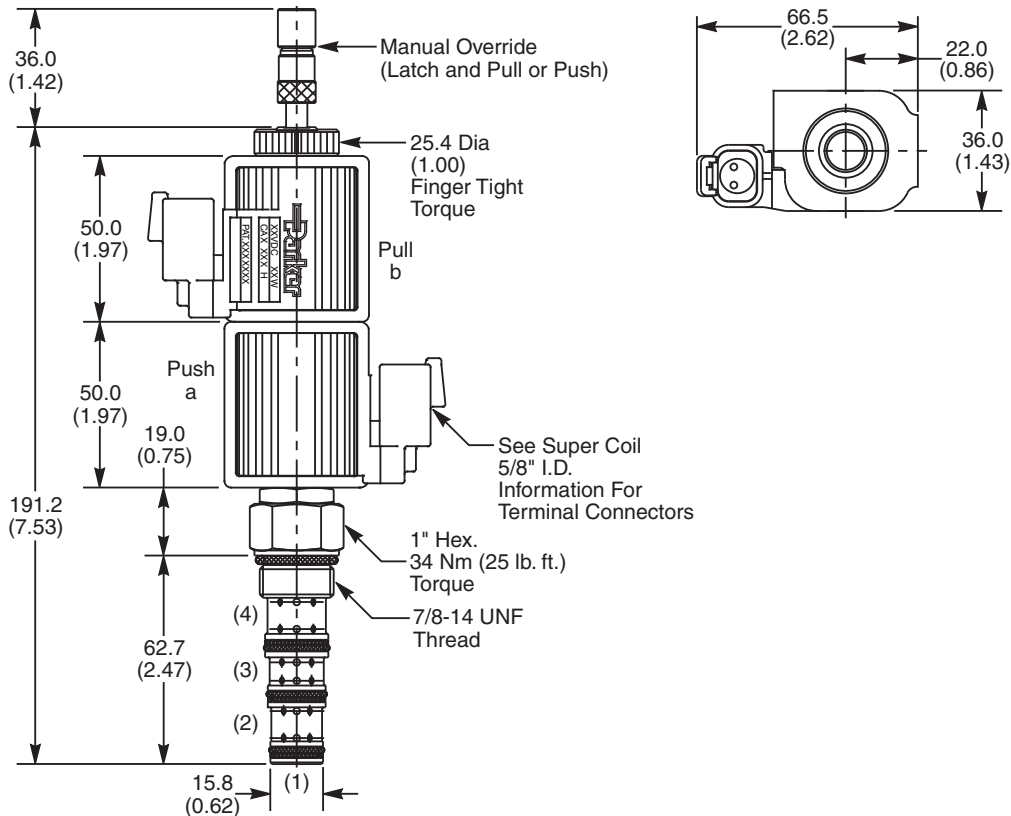

Ordering Information

GS04	57		0	N	D
10 Size Solenoid Valve	Style	Override Option	Screen	Seals	Design Level

Highlighted represents preferred options that offer the shortest lead times. Other options may be available, but at extended lead times.

Coil(s) sold separately. Please see section CE of this catalog, 5/8" Super-Coil (CA series), for ordering information.

Order Bodies Separately
 See section BC

Code	Style
57	High Flow and Pressure ('SP' Coil)

Code	Screen
0	None (Contact factory for OEM requirements)

B10	—	4	—	8T
10 size		4-Way Cavity		Port Size

Code	Override Options
0	None
5	Standard - Center Detent only, Latch Operated, Push and Pull (*40 nt/9 lbs.)

Code	Seals
N	Nitrile

Code	Port Size / Body Material
8T	SAE-8 / Steel (5000 PSI)

Code	Design Level
D	Industry Common Cavity

*Force to push at 210 Bar (3000 PSI). Less to Pull.

Kit	Part Number
Nitrile Seal	SK30506N-1
Fluorocarbon Seal	SK30506V-1



CV
Check Valves
SH
Shuttle Valves
LM
Load/Motor Controls
FC
Flow Controls
PC
Pressure Controls
LE
Logic Elements
DC
Directional Controls
SV
Solenoid Valves
PV
Proportional Valves
CE
Coils & Electronics
BC
Bodies & Cavities
TD
Technical Data

General Description

4-Way, 3 Position, Open Center Spool Valve.
 For additional information see Technical Tips on pages SV2-SV6.

Features

- Four way open center valve designed to operate double acting cylinders and bi-directional motors, etc.
- One piece cartridge housing ensures internal concentricity
- Coil: Waterproof, hermetically sealed, requires no O’Rings; Symmetrical coil can be reversed without affecting performance.

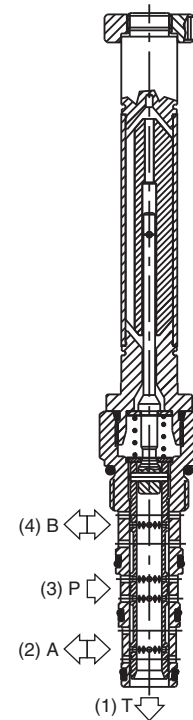
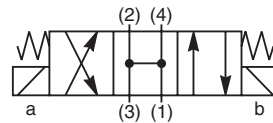
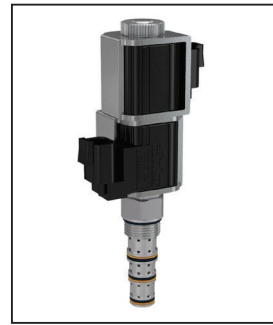

Specifications

Rated Flow	42 LPM (11 GPM)
Maximum Inlet Pressure	350 Bar (5000 PSI)
Maximum Tank Pressure	210 Bar (3000 PSI)
Leakage at 150 SSU (32 cSt)	160 cc/min @ 210 Bar (3000 PSI)
Minimum Operating Voltage	85% of rated voltage at 20°C (72°F).
Response Time	Open 30-60 ms Close 20-40 ms
Cartridge Material	All parts steel. All operating parts hardened steel.
Operating Temp. Range/Seals	-34°C to +121°C (Nitrile) (-30°F to +250°F) -26°C to +204°C (Fluorocarbon) (-15°F to +400°F)
Fluid Compatibility/Viscosity	Mineral-based or synthetic with lubricating properties at viscosities of 45 to 2000 SSU (6 to 420 cSt)
Filtration	ISO 4406 18/16/13, SAE Class 4
Approx. Weight	.26 kg (.58 lbs.)
Cavity	C10-4 (See BC Section for more details)

Performance Curves

Pressure Drop vs. Flow (Through cartridge only)

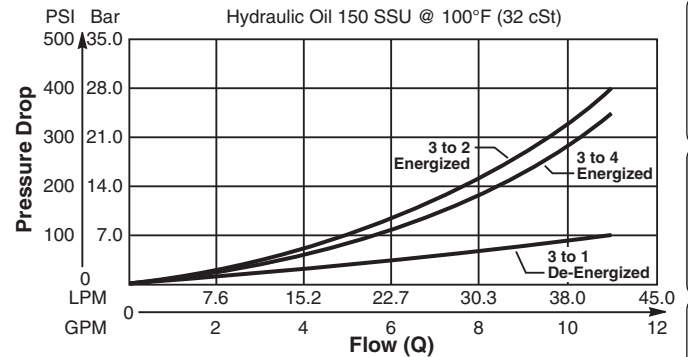

Operating Limits (Measured at 75% of Nominal Current)

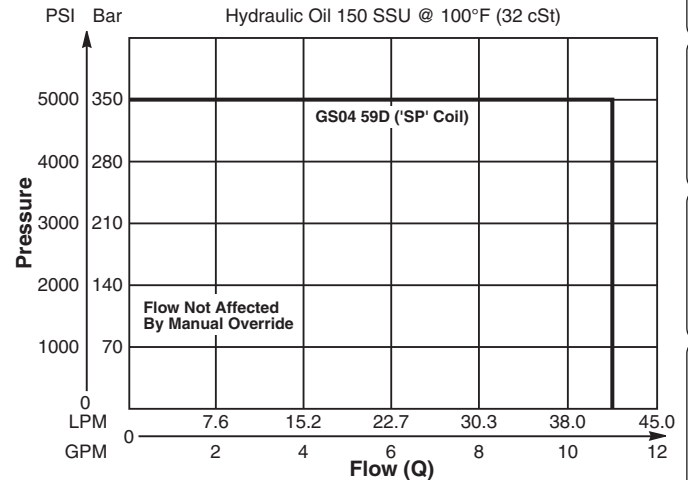

CV
Check Valves

SH
Shuttle Valves

LM
Load/Motor Controls

FC
Flow Controls

PC
Pressure Controls

LE
Logic Elements

DC
Directional Controls

SV
Solenoid Valves

PV
Proportional Valves

CE
Coils & Electronics

BC
Bodies & Cavities

TD
Technical Data

Dimensions Millimeters (Inches)

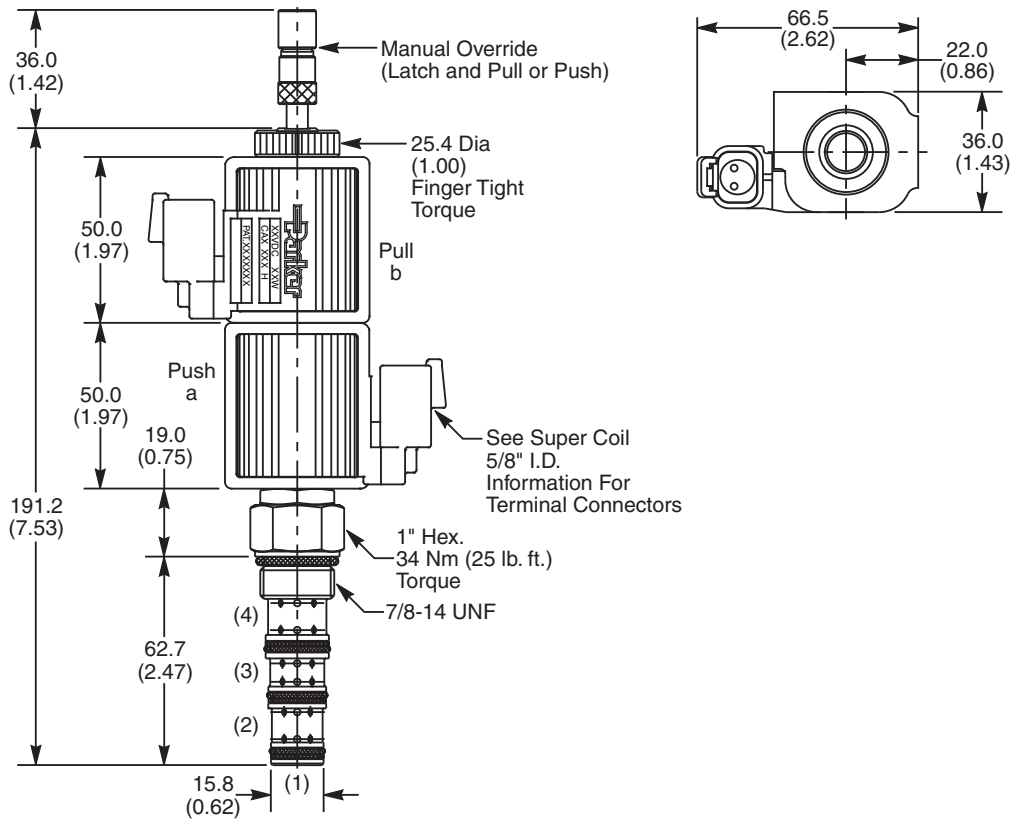

Ordering Information

GS04	59		0	N	D
10 Size Solenoid Valve	Style	Override Option	Screen	Seals	Design Level

Highlighted represents preferred options that offer the shortest lead times. Other options may be available, but at extended lead times.

Coil(s) sold separately. Please see section CE of this catalog, 5/8" Super-Coil (CA series), for ordering information.

Order Bodies Separately
 See section BC

Code	Style
59	High Flow and Pressure ('SP' Coil)

Code	Screen
0	None (Contact factory for OEM requirements)

B10	—	4	—	8T
10 size		4-Way Cavity		Port Size

Code	Override Options
0	None
5	Standard - Center Detent only, Latch Operated, Push and Pull (*40 nt/9 lbs.)

Code	Seals
N	Nitrile

Code	Port Size / Body Material
8T	SAE-8 / Steel (5000 PSI)

Code	Design Level
D	Industry Common Cavity

*Force to push at 210 Bar (3000 PSI). Less to Pull.

Kit	Part Number
Nitrile Seal	SK30506N-1
Fluorocarbon Seal	SK30506V-1

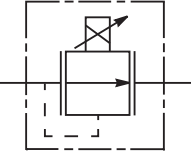
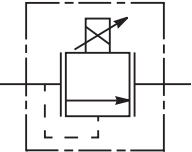
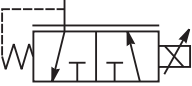
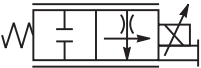
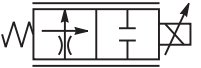
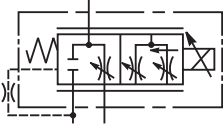
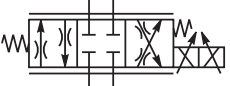
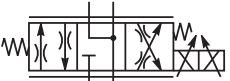

CV	Check Valves
SH	Shuttle Valves
LM	Load/Motor Controls
FC	Flow Controls
PC	Pressure Controls
LE	Logic Elements
DC	Directional Controls
SV	Solenoid Valves
PV	Proportional Valves
CE	Coils & Electronics
BC	Bodies & Cavities
TD	Technical Data

SERIES	CAVITY	DESCRIPTION	FLOW LPM/GPM	PRESSURE BAR/PSI	PAGE NO.	
Technical Tips					PV2-PV5	
PRESSURE RELIEVING						
	AP02B2YP	C08-2	Increase Pressure/Increase Current	5.3/1.4	350/5000	PV6-PV7
	AP04G2YP	C10-2	Increase Pressure/Increase Current	95/25	350/5000	PV8-PV9
	AP02B2YR	C08-2	Decrease Pressure/Increase Current	5.3/1.4	350/5000	PV10-PV11
	AP04G2YR	C10-2	Decrease Pressure/Increase Current	95/25	350/5000	PV12-PV13
PRESSURE REDUCING						
	EPR083R	C08-3L	Pressure Reducing/Relieving Valve	22.7/6	345/5000	PV14-PV15
	EPR111C	C10-3L	Pressure Reducing/Relieving Valve	37.5/10	350/5000	PV16-PV17
FLOW CONTROLS, 2-WAY						
	JP02C 21	C08-3	Flow Control, N.C.	23/6	210/3000	PV18-PV19
	JP04C 21	3X	Flow Control, N.C.	36/9.5	210/3000	PV20-PV21
	JP02P 21	C08-3	Flow Control, N.O.	19/5	210/3000	PV22-PV23
	FLOW CONTROLS, 3-WAY					
	JP04C 31	4C	Priority Flow Control, N.C.	30/8	210/3000	PV24-PV25
DIRECTIONAL CONTROL						
	GP02 51	C08-4	4 Way, 3 Pos - Closed Center	21/5.5	350/5000	PV26-PV27
	GP02 52	C08-4	4 Way, 3 Pos - Closed Center	17/4.5	350/5000	PV26-PV27
	GP02 53	C08-4	4 Way, 3 Pos - Float Center	17/4.5	350/5000	PV28-PV29
	GP02 54	C08-4	4 Way, 3 Pos - Float Center	17/4.5	350/5000	PV28-PV29
	DSP105C1	C10-4	4 Way, 3 Pos - Closed Center	32/8.5	210/3000	PV30-PV32
	DSP105C4	C10-4	4 Way, 3 Pos - Float Center	32/8.5	210/3000	PV30-PV32

CV
Check Valves

SH
Shuttle Valves

LM
Load/Motor Controls

FC
Flow Controls

PC
Pressure Controls

LE
Logic Elements

DC
Directional Controls

SV
Solenoid Valves

PV
Proportional Valves

CE
Coils & Electronics

BC
Bodies & Cavities

TD
Technical Data

INTRODUCTION

This technical tips section is designed to help familiarize you with the Parker line of Proportional Valves. In this section we present common options, technical terms, as well as a brief synopsis of the operation and applications of the various products offered in this section. The intent of this section is to help you in selecting the best products for your application.

COMMON OPTIONS

As you will see, Parker offers a variety of Proportional Valve products. As such, some of the options mentioned below may not be available on all valves. Consult the model coding and dimensions for each valve for specifics. Here are some of the common options available.

Seals: Valves are provided with either a 4301 Polyurethane “D”-Ring, Nitrile, or Fluorocarbon Seals. The “D”-Ring eliminates the need for backup rings. You should match the seal compatibility to the temperature and fluid being used in your application.

Overrides: Overrides are standard on many of the Parker proportional valves. The override is generally a push type that is flush with the end of the tube. Consult the individual catalog pages for more details.

TECHNICAL TERMS

To help in applying our proportional valve line of product, we have listed some technical terms below, as well as some helpful hints in applying our valves.

Ohm's Law: Electrical current is generated as a result of the relationship between input voltage and the resistance to the flow of electrical current. It is represented in equation form by $I = V/R$ (or $V=IR$), where I is current, V is voltage and R is resistance. This is an important relationship to remember when dealing with any electrically operated valves. Proportional valves allow varying control of flow or pressure, dependant on the current signal provided. As coils heat up, their resistance rises. This means a higher voltage must be available to maintain the same amount of pressure or flow. Thus, the application needs to be designed such that the full on position is about 70% of the initial current draw. On the individual catalog pages a maximum control current is specified to help in applying our proportional valves.

PWM: Pulse Width Modulation (PWM) is the preferred signal for controlling electrical current. PWM is on / off voltage in a square wave form. The percent “on” time or duty cycle provides the average voltage. The valve driver adjusts the duty cycle to obtain current control. We recommend valve drivers with current control for optimum performance. PWM signals also usually provide dither for the proportional valve. Dither is a

small back and forth movement of the valve spool around its set position. This rapid movement reduces the friction of the valve and leads to faster, more accurate response.

PWM Frequency: The frequency of a PWM signal is the rate at which the signal is turned on and off. Parker's analog proportional valves are designed to work with low frequency responses between 100-400 Hz. The performance curves on our catalog pages were performed with a PWM signal at 200 Hz.

Hysteresis: Due to various factors, the performance of a proportional valve will show a slightly different performance when the current signal is increasing than it will when the signal is being decreased. This difference is usually expressed as a percentage of total input change and is referred to as the hysteresis of the valve.

Deadband: Cracking or deadband refers to the amount of the control signal that is needed to produce any movement of the spool. Thus, a 20% deadband means that 20% of the control signal is needed before the spool will move.

CV	Check Valves
SH	Shuttle Valves
LM	Load/Motor Controls
FC	Flow Controls
PC	Pressure Controls
LE	Logic Elements
DC	Directional Controls
SV	Solenoid Valves
PV	Proportional Valves
CE	Coils & Electronics
BC	Bodies & Cavities
TD	Technical Data

PRODUCT TYPES / APPLICATIONS

Proportional valves are nothing more than electrically adjustable hydraulic valves. They give the operator nearly infinite adjustment control and flexibility. Parker Hannifin offers various types of proportional flow control, pressure reducing, and relief valves.

Proportional Flow Control Valve

Proportional flow control valves provide pseudo pressure compensation and are used on systems requiring variable electronic control of flow. They allow the operator to vary the control signal to accelerate or decelerate an actuator. A compensator valve can be added to the circuit for enhanced compensation. Some typical applications would include the hoist control for a lift, or the speed control for a winch circuit. Parker offers both normally closed and normally open versions of proportional flow controls.

Normally Closed Proportional Flow Control

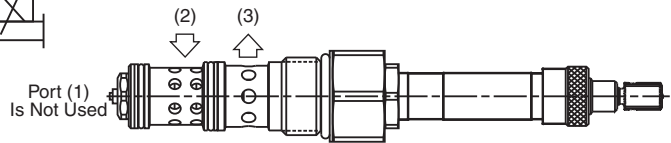
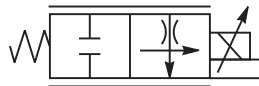

OPERATION - With the solenoid coil de-energized, the spool is held in a closed position by the spring force. When the solenoid coil is energized, the amperage of the signal moves the spool into an open position.

The spool is held in this position by a balance between spring force and electrical force. As the current increases, the spools opens further; allowing more flow. As the current decreases, the spool begins closing; allowing less flow. Pseudo compensation is obtained by the pressure drop across the orifices in the spool.

Normally Open Proportional Flow Control

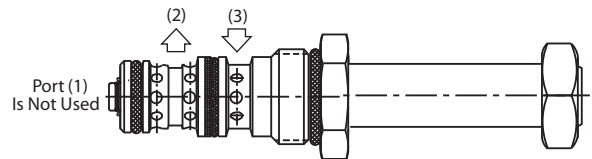
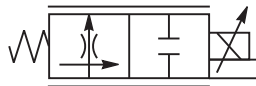

OPERATION - With the solenoid coil de-energized, the spool is held in an open position by spring force; allowing full flow to pass. As the solenoid coil is energized, the spool begins to move away from a full open position; allowing less flow to pass. Once a full electronic signal is given, the spool is held in a closed position; allowing no flow to pass.

As the electronic signal is then reduced, the spool begins to open; allowing flow to pass again. Once a constant electronic signal is given, the spool is held in that position by a balance between electronic force and spring force. Pseudo compensation is obtained by the pressure drop across the orifices in the spool.

Proportional Priority Bypass Flow Control

The proportional priority bypass flow controls allow electronic control of the flow setting for the priority flow circuit. The priority flow remains constant regardless of changes in load or pressure. The excess inlet flow is diverted or bypassed to tank. The bypass port must not have any restrictions or performance will be hindered.

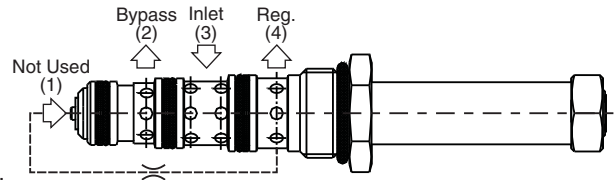
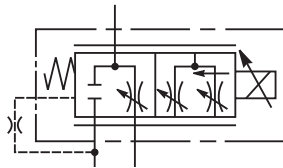

OPERATION - Flow enters the valve through port 3. With the coil de-energized, flow is bypassed to port 2. When the coil is energized, the internal orifice is increased allowing pressure compensated flow to the priority port (port 4). The excess flow is bypassed to port 2. As input current is increased, the priority flow increases and the bypass flow decreases. As the current is decreased, priority flow decreases and bypass flow is increased.

CV
Check Valves
SH
Shuttle Valves
LM
Load/Motor Controls
FC
Flow Controls
PC
Pressure Controls
LE
Logic Elements
DC
Directional Controls
SV
Solenoid Valves
PV
Proportional Valves
CE
Coils & Electronics
BC
Bodies & Cavities
TD
Technical Data

Normally Closed Proportional Pressure Reducing / Relieving Valve

Normally Closed Proportional Pressure Reducing/Relieving Valves are used to electronically reduce the inlet pressure to one leg of a hydraulic circuit. In addition these valves act as a relief valve, relieving any shocks or surges that occur between its regulating port and the actuator. Pilot operated are generally slower on response due to the two stage performance, but can have a reduced pressure as high as 3000 psi.

Pilot Operated

OPERATION - With the solenoid coil de-energized, the pilot dart is held open by the spring force. This allows the main spool to close and restricts flow from going from the inlet (2) port to the regulated port (1).

As the electronic signal is applied to the coil, the pilot dart is moved towards the pilot seat restricting pilot flow. This restriction raises the effective pressure inside the chamber between the spool and the pilot seat, allowing the spool to travel away from the pilot seat to a position where the pressure at inlet (2) is connected to the regulated pressure port (1).

At this point, reduced pressure becomes a function of the electronic signal. As long as the electronic signal is constant, the reduced pressure at the regulated pressure port (2) will remain fixed regardless of any changes in inlet flow or inlet pressure. As the electronic signal increases or decreases, the reduced pressure at port (1) will change with respect to the change in the electronic signal.

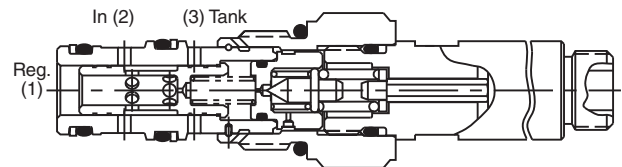
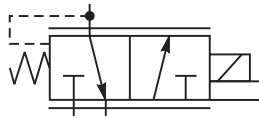

CV
Check Valves

SH
Shuttle Valves

LM
Load/Motor Controls

FC
Flow Controls

PC
Pressure Controls

LE
Logic Elements

DC
Directional Controls

SV
Solenoid Valves

PV
Proportional Valves

CE
Coils & Electronics

BC
Bodies & Cavities

TD
Technical Data

**Normally Closed
Proportional Relief Valve**

Normally closed proportional relief valves are used to electronically control the system pressure. These valves are ideal for circuits with varying system pressure demands. A small flow pilot version of the normally closed proportional relief is also offered for piloting a larger logic element or vented relief valve. The normally closed relief defaults to a maximum pressure setting (i.e. 3000 psi) when there is no current applied.

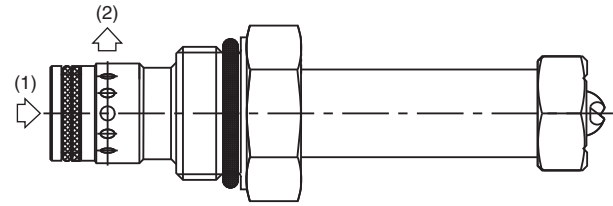
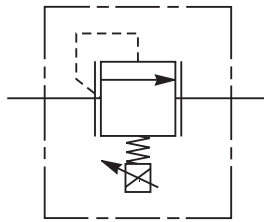

OPERATION - With the solenoid coil de-energized, the pilot dart is held closed by the spring. As current is applied to the coil, the pilot dart is moved creating less restriction of the pilot flow. As this restriction is reduced with the increasing current, the pressure setting also decreases. Once a constant electronic signal is given, the pilot dart is held in a given position, holding the pressure setting. This is maintained by the balance between the electronic spring force and the inlet pressure.

**Normally Open
Proportional Relief Valve**

Normally open proportional relief valves are used to electronically control the system pressure. These valves are ideal for circuits with varying system pressure demands. A small flow pilot version of the normally open proportional relief is also offered for piloting a larger logic element or vented relief valve. The normally open relief defaults to minimum system pressure (i.e. 150 psi) when there is no current applied. Normally closed versions are also available upon request.

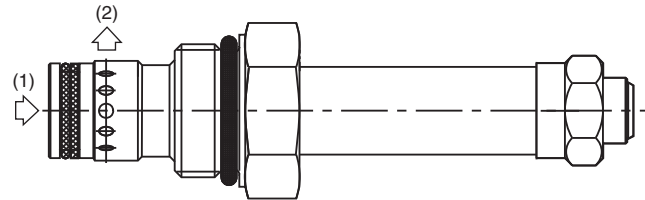
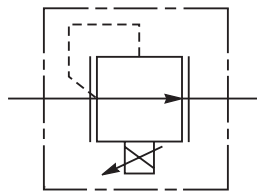

OPERATION - With the solenoid coil de-energized, the pilot dart is held open by the spring. This allows the main spool to open at minimum pressure 10.4 Bar (150 psi). As current is applied to the coil, the pilot dart is moved towards the pilot seat restricting pilot flow. This restriction raises the effective pressure setting of the valve. Once a constant electronic signal is given, the pilot dart is held in a given position, holding the pressure setting. This is maintained by a balance between electronic spring force and inlet pressure. As the electronic signal is reduced, the pilot dart is moved away from the pilot seat. This lowers the effective pressure setting of the valve.

CV	Check Valves
SH	Shuttle Valves
LM	Load/Motor Controls
FC	Flow Controls
PC	Pressure Controls
LE	Logic Elements
DC	Directional Controls
SV	Solenoid Valves
PV	Proportional Valves
CE	Coils & Electronics
BC	Bodies & Cavities
TD	Technical Data

General Description

Proportional Relief Valve. Increasing Pressure With Increasing Current. For additional information see Technical Tips on pages PV2-PV5.

Features

- Analog Proportional Relief Valve regulates pressure proportionally to the solenoid current
- Direct acting poppet design
- One piece cartridge housing ensures internal concentricity
- Coil: Waterproof, hermetically sealed, requires no O'Rings; Symmetrical coil can be reversed without affecting performance.

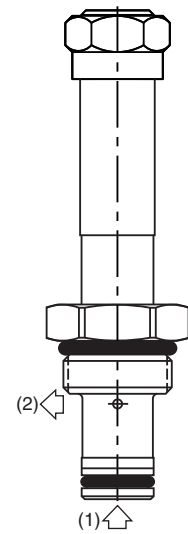
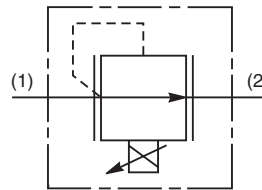
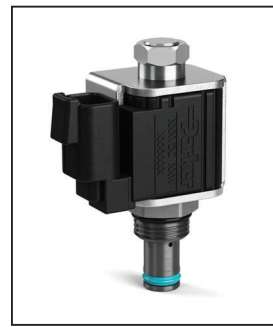

Specifications

Rated Flow (At 70 PSI ΔP)	21C	3.0 LPM (0.8 GPM)
	35C	1.3 LPM (.35 GPM)
Max. Pressure At Port 1 @ 75% Input Current	21C	210 Bar (3000 PSI)
	35C	350 Bar (5000 PSI)
Port 2 Pressure Limit	103 Bar (1000 PSI)	
Hysteresis @ 200 Hz PWM	5%	
Cracking Pressure	21C	0.21 Bar (3 PSI)
	35C	0.35 Bar (5 PSI)
Cartridge Material	All parts steel. All operating parts hardened steel.	
Operating Temp. Range/Seals	-37°C to +93°C ("D"-Ring) (-35°F to +200°F) -34°C to +121°C (Nitrile Buna-N) (-30°F to +250°F) -26°C to +204°C (Fluorocarbon) (-15°F to +400°F)	
Fluid Compatibility/Viscosity	Mineral-based or synthetic with lubricating properties at viscosities of 45 to 2000 SSU (6 to 420 cSt)	
Filtration	ISO-4406 18/16/13, SAE Class 4	
Approx. Weight	0.06 kg (0.14 lbs.)	
Cavity	C08-2 (See BC Section for more details)	

Performance Curves

▲ PWM Current Regulator Recommended

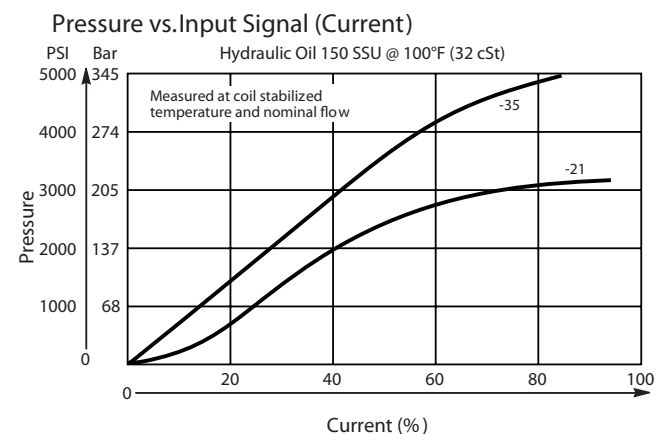
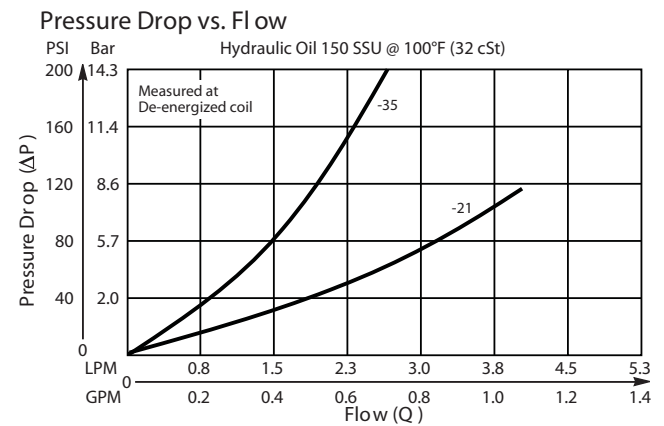

- CV
- Check Valves
- SH
- Shuttle Valves
- LM
- Load/Motor Controls
- FC
- Flow Controls
- PC
- Pressure Controls
- LE
- Logic Elements
- DC
- Directional Controls
- SV
- Solenoid Valves
- PV
- Proportional Valves
- CE
- Coils & Electronics
- BC
- Bodies & Cavities
- TD
- Technical Data

Dimensions Millimeters (Inches)

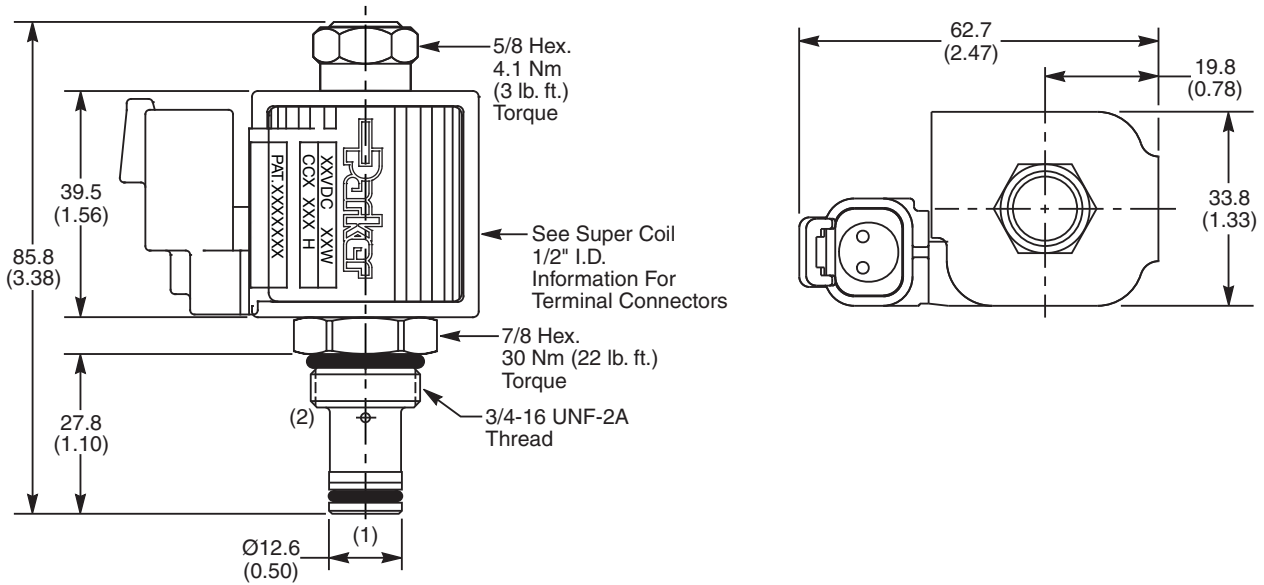

Ordering Information

AP02B2YP

08 Size Proportional Relief Valve Max Relief Setting

Highlighted represents preferred options that offer the shortest lead times. Other options may be available, but at extended lead times.

Coil(s) sold separately. Please see section CE of this catalog, 1/2" Super-Coil (CC series), for ordering information.

Code	Max Relief Setting
21C	210 Bar (3000 PSI)
35C	350 Bar (5000 PSI)

Code	Seals
Omit	"D"-Ring

Order Bodies Separately
 See section BC

B08 - **2** - **6T**

08 size 2-Way Cavity Port Size

Code	Porting / Body Material
6T	SAE-6 / Steel (5000 PSI)

Kit	Part Number
D-Ring Seal	SK08-2
Nitrile Seal	SK08-2
Fluorocarbon Seal	SK08-2V

- CV Check Valves
- SH Shuttle Valves
- LM Load/Motor Controls
- FC Flow Controls
- PC Pressure Controls
- LE Logic Elements
- DC Directional Controls
- SV Solenoid Valves
- PV Proportional Valves
- CE Coils & Electronics
- BC Bodies & Cavities
- TD Technical Data

General Description

Proportional Relief Valve. Increasing Pressure With Increasing Current. For additional information see Technical Tips on pages PV2-PV5.

Features

- Pilot operated spool-type design fits industry common cavity (10-2)
- Relieving pressure output is proportional to DC current input
- Precise setting of factory preset pressure in energized mode
- One piece cartridge housing ensures internal concentricity
- Coil: Waterproof, hermetically sealed, requires no O’Rings; Symmetrical coil can be reversed without affecting performance.

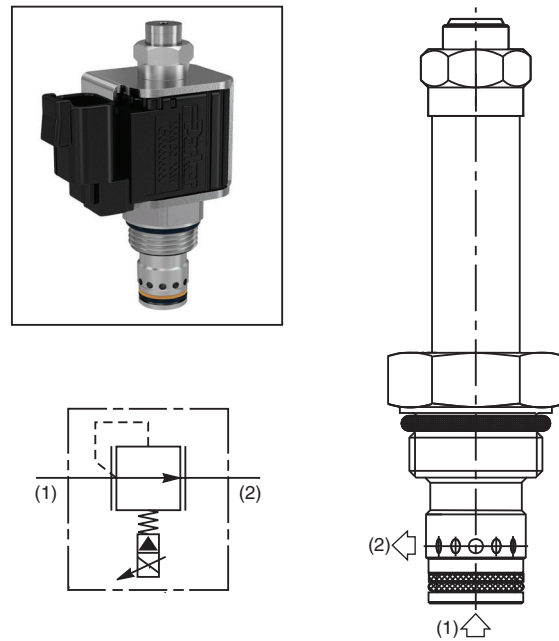

Specifications

Rated Flow (At 300 PSI ΔP) When Coil is Fully De-Energized	95 LPM (25 GPM)
Factory Set Relief Pressure When Coil De-Energized Measured at 45 LPM (12 GPM)	21C 210 Bar (3000 PSI) 35C 350 Bar (5000 PSI)
Port 2 Pressure Limit	103 Bar (1000 PSI)
Hysteresis @ 200 Hz PWM	< 7% of Maximum Pressure Setting
Response Time At 75% of Nominal Voltage Change (Measured To 90% of Press. Change)	To Unload 10ms To Load 21C 60 ms 35C 80 ms
Cartridge Material	All parts steel. All operating parts hardened steel.
Operating Temp. Range/Seals	-34°C to +121°C (Nitrile Buna-N) (-30°F to +250°F) -26°C to +204°C (Fluorocarbon) (-15°F to +400°F)
Fluid Compatibility/Viscosity	Mineral-based or synthetic with lubricating properties at viscosities of 45 to 2000 SSU (6 to 420 cSt)
Filtration	ISO-4406 18/16/13, SAE Class 4
Approx. Weight	0.14 kg (0.31 lbs.)
Cavity	C10-2 (See BC Section for more details)

Performance Curves

▲ PWM Current Regulator Recommended

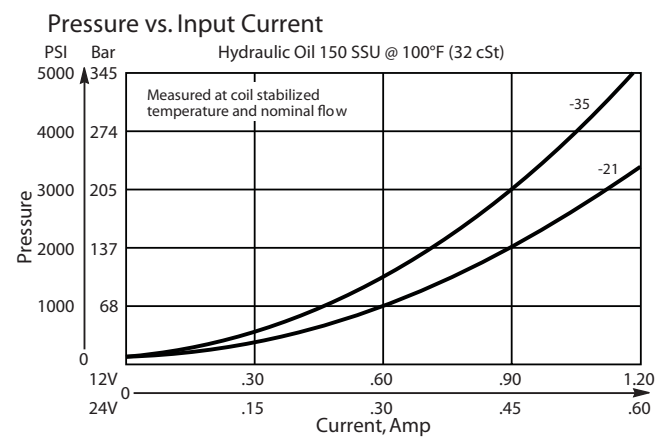
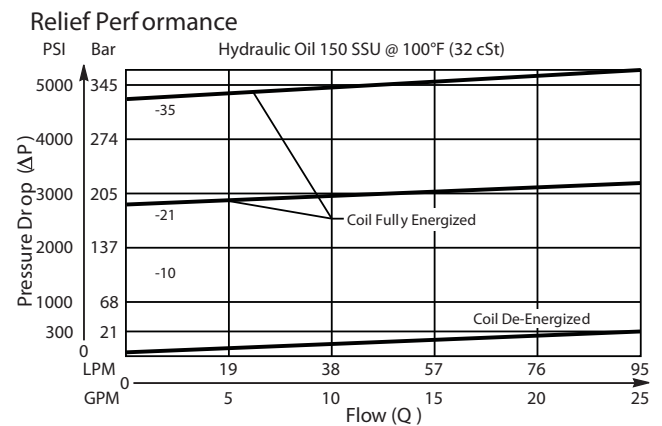

CV
Check Valves

SH
Shuttle Valves

LM
Load/Motor Controls

FC
Flow Controls

PC
Pressure Controls

LE
Logic Elements

DC
Directional Controls

SV
Solenoid Valves

PV
Proportional Valves

CE
Coils & Electronics

BC
Bodies & Cavities

TD
Technical Data

Dimensions Millimeters (Inches)

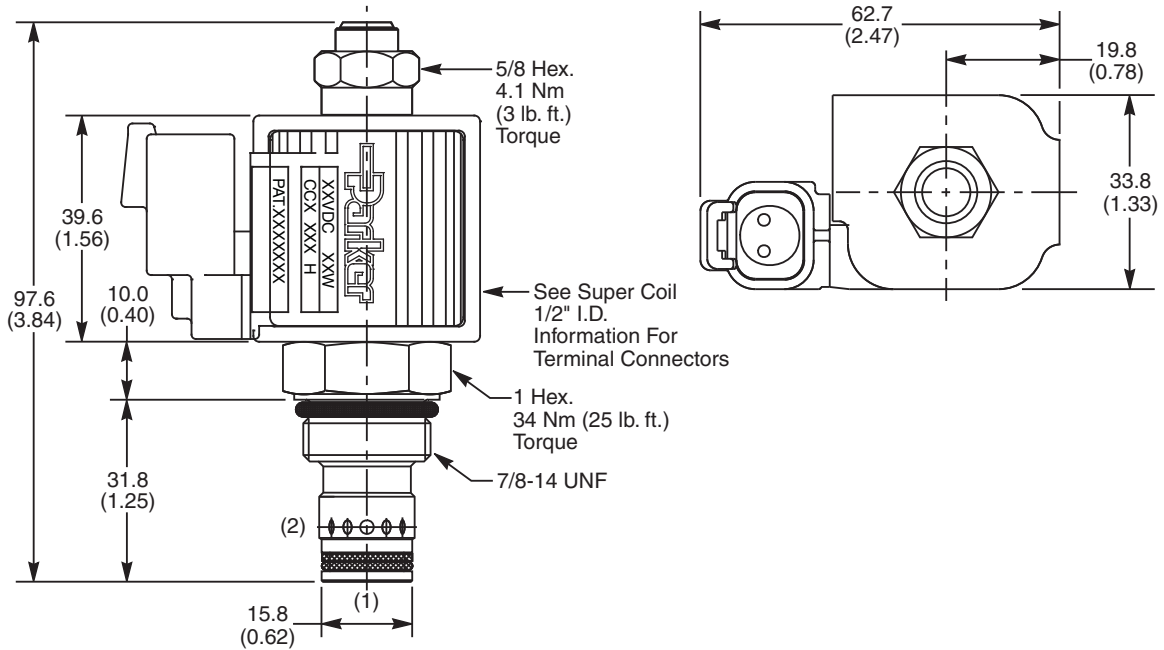

Ordering Information

AP04G2YP		N
10 Size Proportional Relief Valve	Max Relief Setting	Seals

Highlighted represents preferred options that offer the shortest lead times. Other options may be available, but at extended lead times.

Coil(s) sold separately. Please see section CE of this catalog, 1/2" Super-Coil (CC series), for ordering information.

Order Bodies Separately See section BC

Code	Max Relief Setting
21C	210 Bar (3000 PSI)
35C	350 Bar (5000 PSI)

Code	Seals
N	Nitrile

B10	—	2	—	8T
10 size		2-Way Cavity		Port Size

Code	Porting / Body Material
8T	SAE-8 / Steel (5000 PSI)

Kit	Part Number
Nitrile Seal	SK30503N-1
Fluorocarbon Seal	SK30503V-1

CV
Check Valves
SH
Shuttle Valves
LM
Load/Motor Controls
FC
Flow Controls
PC
Pressure Controls
LE
Logic Elements
DC
Directional Controls
SV
Solenoid Valves
PV
Proportional Valves
CE
Coils & Electronics
BC
Bodies & Cavities
TD
Technical Data

General Description

Proportional Relief Valve. Decreasing Pressure With Increasing Current. For additional information see Technical Tips on pages PV2-PV5.

Features

- Analog Proportional Relief Valve regulates pressure proportionally to the input solenoid current
- Direct acting poppet design
- One piece cartridge housing ensures internal concentricity
- Coil: Waterproof, hermetically sealed, requires no O’Rings; Symmetrical coil can be reversed without affecting performance.

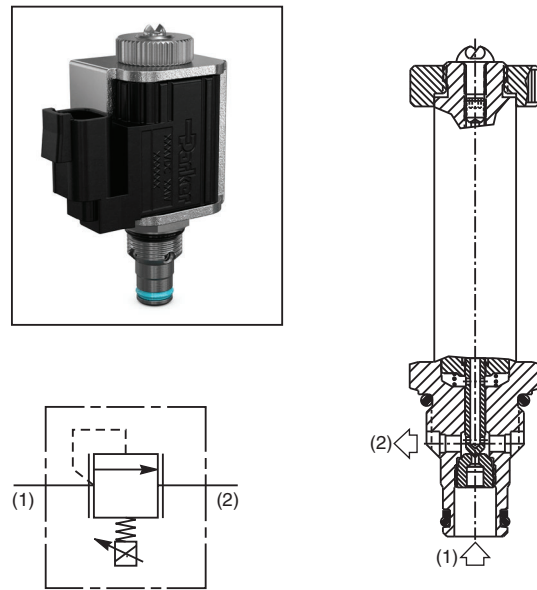

Specifications

Rated Flow (At 70 PSI ΔP)	21A 3.0 LPM (0.8 GPM) 35A 1.3 LPM (.35 GPM)
Factory Set Relief Pressure When De-Energized (±5% -Std. ±2% - Low Variation)	21A 210 Bar (3000 PSI) 35A 350 Bar (5000 PSI)
Port 2 Pressure Limit	103 Bar (1000 PSI)
Hysteresis @ 200 Hz PWM	< 10%
Cracking Pressure	21C 0.21 Bar (3 PSI) 35C 0.35 Bar (5 PSI)
Cartridge Material	All parts steel. All operating parts hardened steel.
Operating Temp. Range/Seals	-37°C to +93°C (“D”-Ring) (-35°F to +200°F) -34°C to +121°C (Nitrile Buna-N) (-30°F to +250°F) -26°C to +204°C (Fluorocarbon) (-15°F to +400°F)
Fluid Compatibility/ Viscosity	Mineral-based or synthetic with lubricating properties at viscosities of 45 to 2000 SSU (6 to 420 cSt)
Filtration	ISO-4406 18/16/13, SAE Class 4
Approx. Weight	0.09 kg (0.19 lbs.)
Cavity	C08-2 (See BC Section for more details)

Performance Curves

▲ PWM Current Regulator Recommended

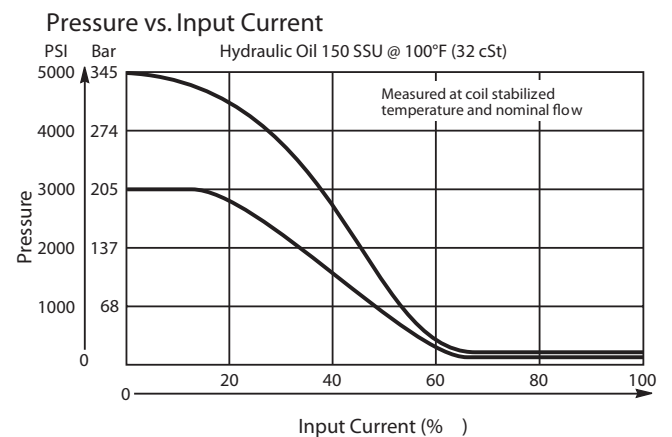
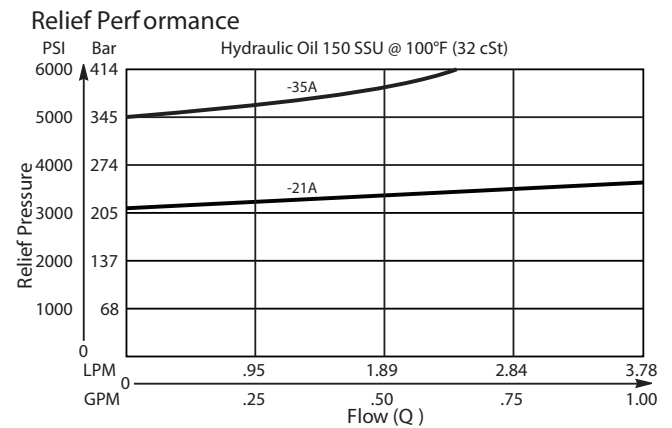

CV
Check Valves

SH
Shuttle Valves

LM
Load/Motor Controls

FC
Flow Controls

PC
Pressure Controls

LE
Logic Elements

DC
Directional Controls

SV
Solenoid Valves

PV
Proportional Valves

CE
Coils & Electronics

BC
Bodies & Cavities

TD
Technical Data

Dimensions Millimeters (Inches)

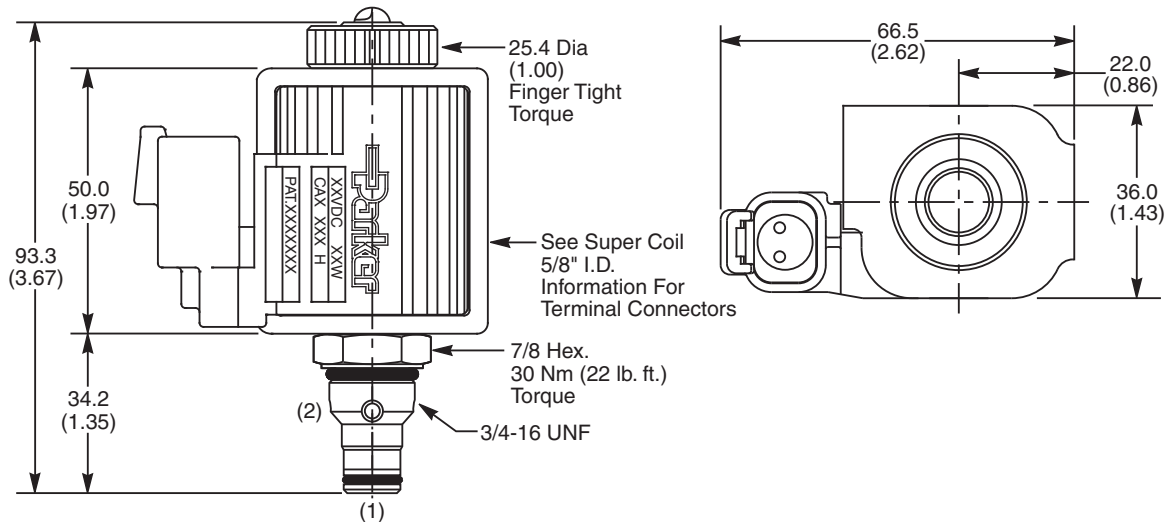

Ordering Information

AP02B2YR		L
08 Size Proportional Relief Valve	Max Relief Setting	Low Variation Now Standard

Highlighted represents preferred options that offer the shortest lead times. Other options may be available, but at extended lead times.

Coil(s) sold separately. Please see section CE of this catalog, 5/8" Super-Coil (CA series), for ordering information.

Order Bodies Separately See section BC

Code	Max Relief Setting
21A	210 Bar (3000 PSI)
35A	350 Bar (5000 PSI)

Code	Seals
Omit	"D"-Ring

B08	—	2	—	6T
08 size		2-Way Cavity		Port Size

Code	Porting / Body Material
6T	SAE-6 / Steel (5000 PSI)

Kit	Part Number
D-Ring Seal	SK08-2
Nitrile Seal	SK08-2
Fluorocarbon Seal	SK08-2V

CV
Check Valves
SH
Shuttle Valves
LM
Load/Motor Controls
FC
Flow Controls
PC
Pressure Controls
LE
Logic Elements
DC
Directional Controls
SV
Solenoid Valves
PV
Proportional Valves
CE
Coils & Electronics
BC
Bodies & Cavities
TD
Technical Data

General Description

Proportional Relief Valve. Decreasing Pressure With Increasing Current. For additional information see Technical Tips on pages PV2-PV5.

Features

- Pilot operated spool-type design
- Precise setting of factory preset pressure in de-energized mode
- One piece cartridge housing ensures internal concentricity
- Coil: Waterproof, hermetically sealed, requires no O’Rings; Symmetrical coil can be reversed without affecting performance.

Specifications

Rated Flow (At 300 PSI ΔP) When Coil is Fully Energized	95 LPM (25 GPM)
Factory Set Relief Pressure When Coil De-Energized Measured at 45 LPM (12 GPM)	21C 210 Bar (3000 PSI) 35C 350 Bar (5000 PSI)
Port 2 Pressure Limit	103 Bar (1000 PSI)
Hysteresis @ 200 Hz PWM	< 7% of Maximum Pressure Setting
Response Time At 75% of Nominal Voltage Change (Measured To 90% of Press. Change)	To Unload 45ms To Load 25 ms
Cartridge Material	All parts steel. All operating parts hardened steel.
Operating Temp. Range/Seals	-34°C to +121°C (Nitrile) (-30°F to +250°F) -26°C to +204°C (Fluorocarbon) (-15°F to +400°F)
Fluid Compatibility/Viscosity	Mineral-based or synthetic with lubricating properties at viscosities of 45 to 2000 SSU (6 to 420 cSt)
Filtration	ISO-4406 18/16/13, SAE Class 4
Approx. Weight	0.14 kg (0.30 lbs.)
Cavity	C10-2 (See BC Section for more details)

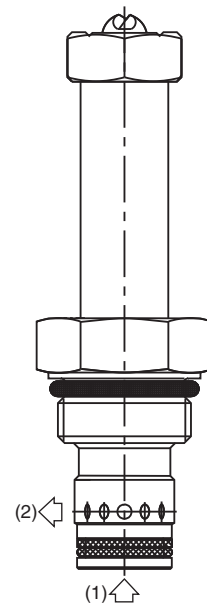
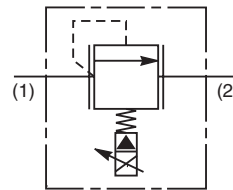

Performance Curves

▲ PWM Current Regulator Recommended

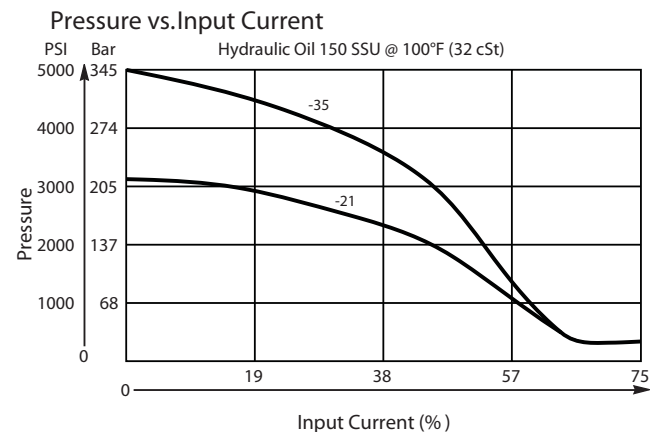
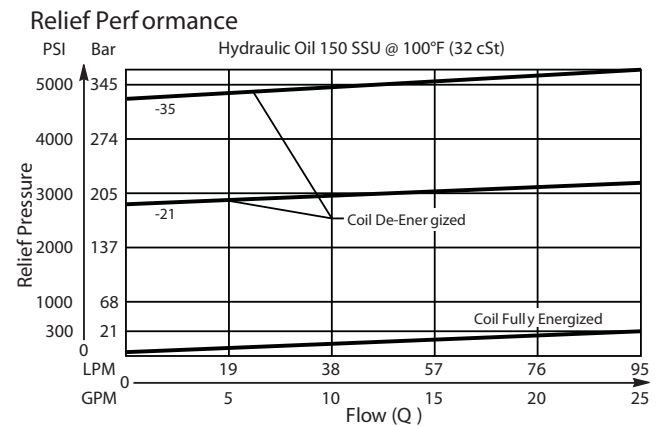

- CV
- Check Valves
- SH
- Shuttle Valves
- LM
- Load/Motor Controls
- FC
- Flow Controls
- PC
- Pressure Controls
- LE
- Logic Elements
- DC
- Directional Controls
- SV
- Solenoid Valves
- PV
- Proportional Valves
- CE
- Coils & Electronics
- BC
- Bodies & Cavities
- TD
- Technical Data

Dimensions Millimeters (Inches)

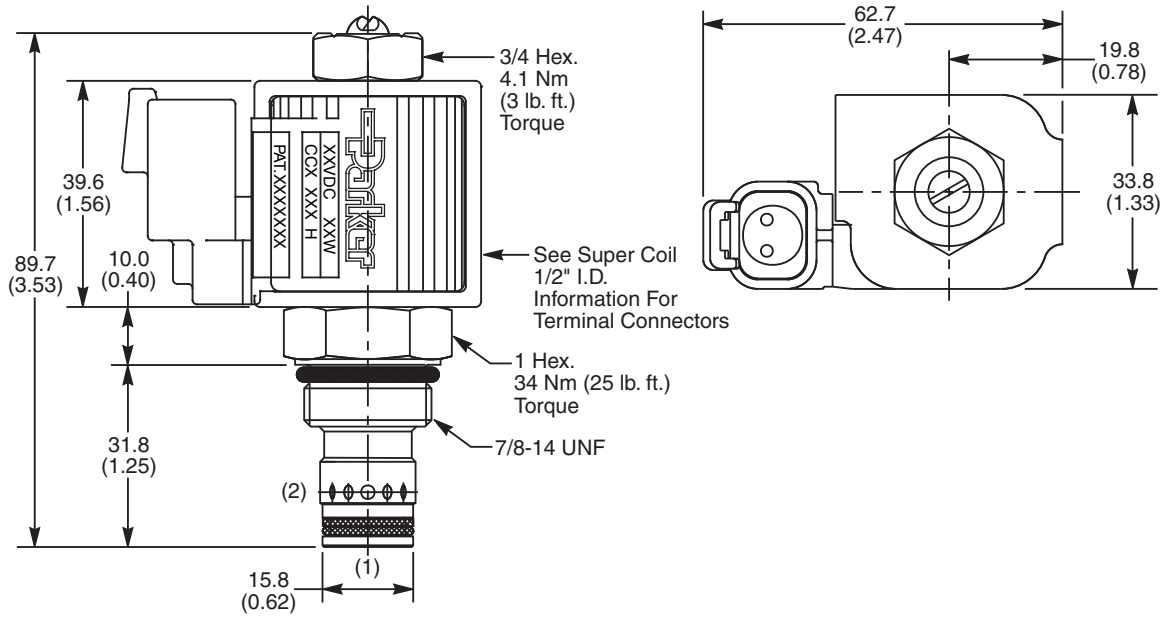

Ordering Information

AP04G2YR **N**

10 Size Proportional Relief Valve Max Relief Setting Seals

Highlighted represents preferred options that offer the shortest lead times. Other options may be available, but at extended lead times.

Coil(s) sold separately. Please see section CE of this catalog, 1/2" Super-Coil (CC series), for ordering information.

Order Bodies Separately See section BC

Code	Max Relief Setting
21C	210 Bar (3000 PSI)
35C	350 Bar (5000 PSI)

Code	Seals
N	Nitrile

B10 - **2** - **8T**

10 size 2-Way Cavity Port Size

Code	Porting / Body Material
8T	SAE-8 / Steel (5000 PSI)

Kit	Part Number
Nitrile Seal	SK30503N-1
Fluorocarbon Seal	SK30503V-1

CV
Check Valves

SH
Shuttle Valves

LM
Load/Motor Controls

FC
Flow Controls

PC
Pressure Controls

LE
Logic Elements

DC
Directional Controls

SV
Solenoid Valves

PV
Proportional Valves

CE
Coils & Electronics

BC
Bodies & Cavities

TD
Technical Data

General Description

Pilot Operated, Pressure Increasing with Current Proportional Pressure Reducing/ Relieving Valve. For additional information see Technical Tips on pages PV2-PV5.

Features

- Low hysteresis
- High flow capacity
- 400 Hz PWM signal preferred
- No dynamic seals
- Screw style manual override standard
- Polyurethane “D”-ring eliminates the need for back-up rings

Specifications

Rated Flow	22.7 LPM (6 GPM)
Max. Input Press. At Port 1	345 Bar (5000 PSI)
Max. Internal Leakage De-energised	230 cc/min (14 in ³ /min)
Hysteresis @ 400 Hz PWM	4% with 30% to 50% duty cycle
Power Consumption	8.4 Watts at max. reduced pressure
Frequency	200-600 Hz (PWM)
Continuous Duty Control Current	12VDC .730A 24VDC .365A
Cartridge Material	All parts steel. All operating parts hardened steel.
Operating Temp. Range/Seals	-37°C to +93°C (“D”-Ring) (-35°F to +200°F) -34°C to +121°C (Nitrile Buna-N) (-30°F to +250°F) -26°C to +204°C (Fluorocarbon) (-15°F to +400°F)
Fluid Compatibility/ Viscosity	Mineral-based or synthetic with lubricating properties at viscosities of 45 to 2000 SSU (6 to 420 cSt)
Filtration	ISO-4406 18/16/13, SAE Class 4
Approx. Weight	0.25 kg (0.55 lbs.) With coil
Cavity	C08-3L (See BC Section for more details)

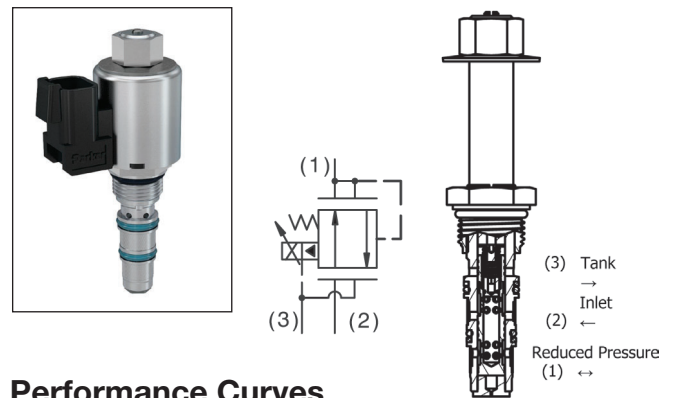

Performance Curves

Current Regulator PWM Recommended

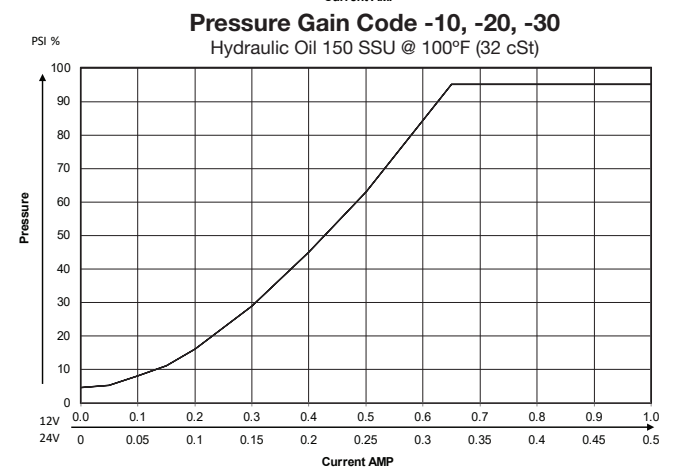
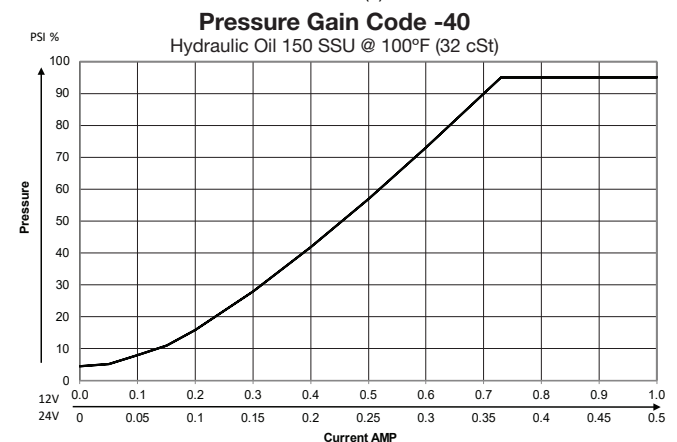
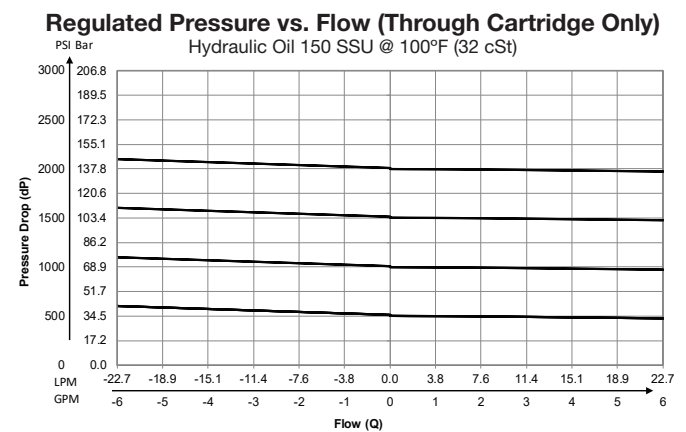

CV
Check Valves

SH
Shuttle Valves

LM
Load/Motor Controls

FC
Flow Controls

PC
Pressure Controls

LE
Logic Elements

DC
Directional Controls

SV
Solenoid Valves

PV
Proportional Valves

CE
Coils & Electronics

BC
Bodies & Cavities

TD
Technical Data

Dimensions Millimeters (Inches)

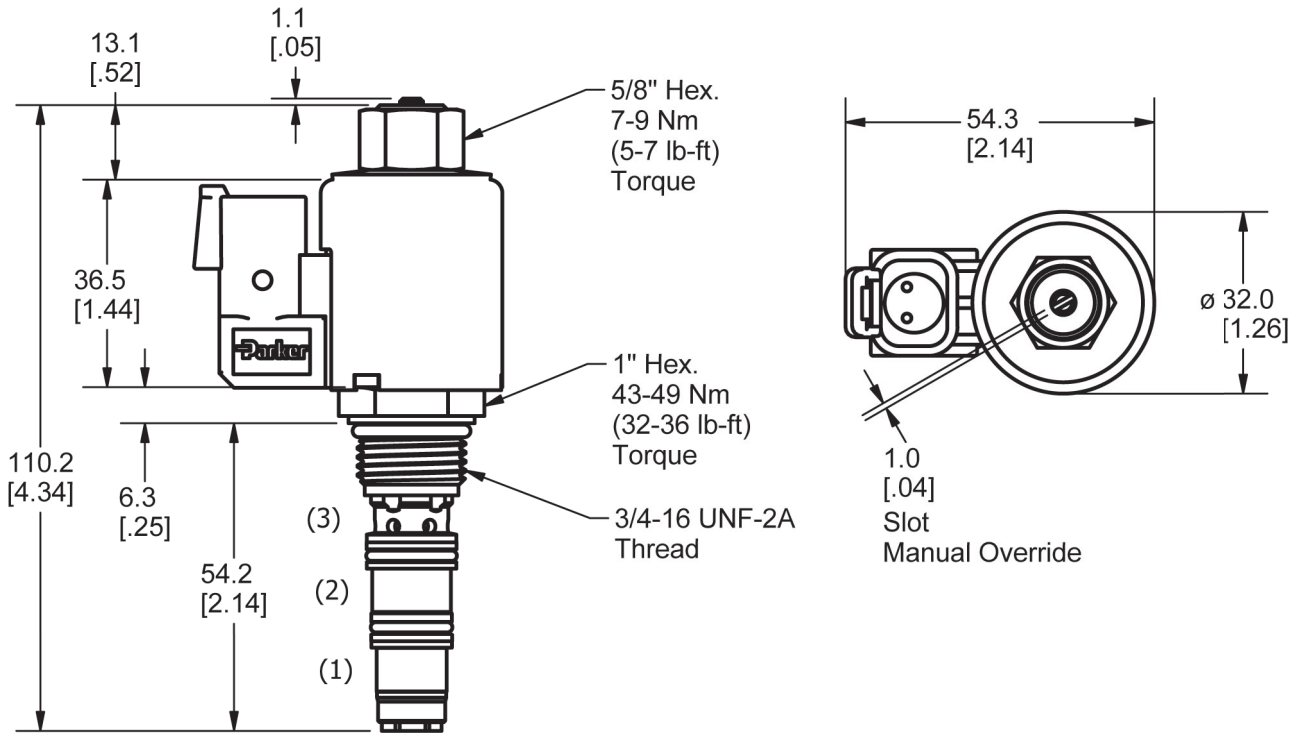

Ordering Information

EPR083	R	
08 Size Proportional Valve	Style	Pressure Range

Highlighted represents preferred options that offer the shortest lead times. Other options may be available, but at extended lead times.

Coil(s) sold separately. Please see section CE of this catalog, 1/2" Coil Short Proportional (SW7L series), for ordering information.

Order Bodies Separately
 See section BC

Code	Coil Type
R	Pilot operated increasing "rising" pressure

Code	Seals
Omit	"D"-Ring

B08	—	3L	—	8T
08 size		3-Way Cavity		Port Size

Code	Pressure Range (Output)
20	138 Bar (2000 PSI)
40	276 Bar (4000 PSI)

Code	Porting / Body Material
8T	SAE-8 / Steel (5000 PSI)

Kit	Part Number
D-Ring Seal	SK08-3
Nitrile Seal	SK08-3
Fluorocarbon Seal	SK08-3V



CV	Check Valves
SH	Shuttle Valves
LM	Load/Motor Controls
FC	Flow Controls
PC	Pressure Controls
LE	Logic Elements
DC	Directional Controls
SV	Solenoid Valves
PV	Proportional Valves
CE	Coils & Electronics
BC	Bodies & Cavities
TD	Technical Data

General Description

Pilot Operated, Normally Closed, Proportional Pressure Reducing/Relieving Valve. For additional information see Technical Tips on pages PV2-PV5.

Features

- High flow capacity
- Low hysteresis
- 400 Hz PWM signal preferred
- No dynamic seals
- Polyurethane "D"-Ring eliminates need for backup rings

Specifications

Rated Flow	37.5 LPM (10 GPM)
Maximum Input Pressure at Port 2	350 Bar (5000 PSI)
Maximum Internal Leakage	0.5 LPM (0.13 GPM) @ 20.7 Bar (300 PSI) 0.95 LPM (0.25 GPM) @ 207 Bar (3000 PSI)
Hysteresis @ 400 Hz PWM	4% with 60% duty cycle
Power Consumption	9 watts at max. reduced pressure
Frequency	200-600 Hz (PWM)
Maximum Control Current	12 VDC .90A 24 VDC .45A
Cartridge Material	All parts steel. All operating parts hardened steel.
Operating Temp. Range/Seals	-37°C to +93°C ("D"-Ring) (-35°F to +200°F) -34°C to +121°C (Nitrile) (-30°F to +250°F) -26°C to +204°C (Fluorocarbon) (-15°F to +400°F)
Fluid Compatibility/Viscosity	Mineral-based or synthetic with lubricating properties at viscosities of 45 to 2000 SSU (6 to 420 cSt)
Filtration	ISO-4406 18/16/13, SAE Class 4
Approx. Weight	0.59 kg (1.3 lbs.)
Cavity	C10-3L (See BC Section for more details)

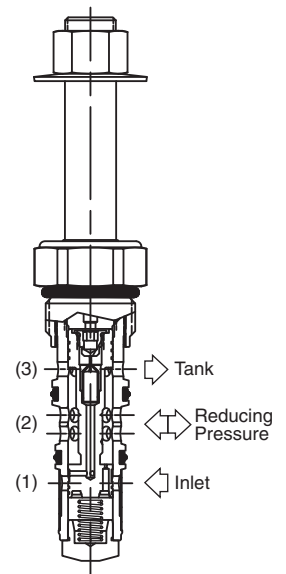
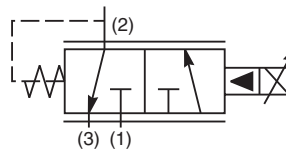

Performance Curves

▲ PWM Current Regulator Recommended

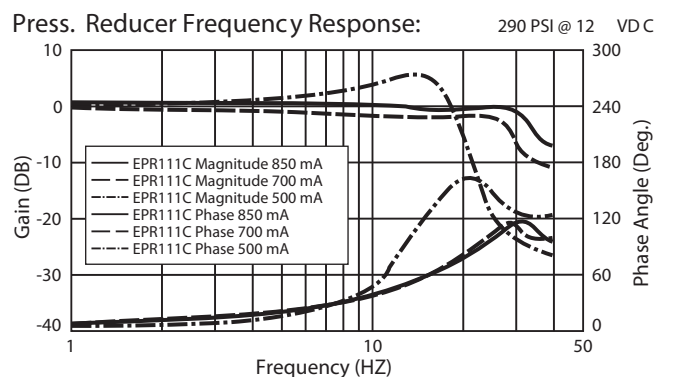
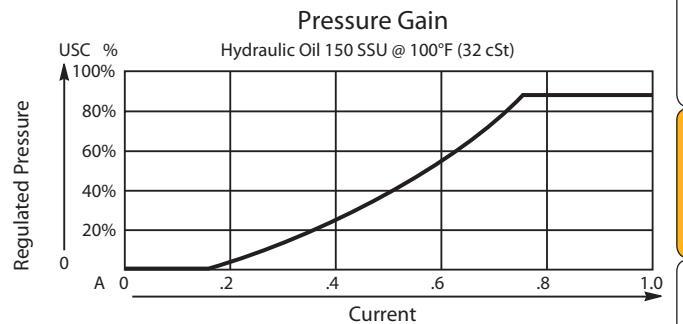
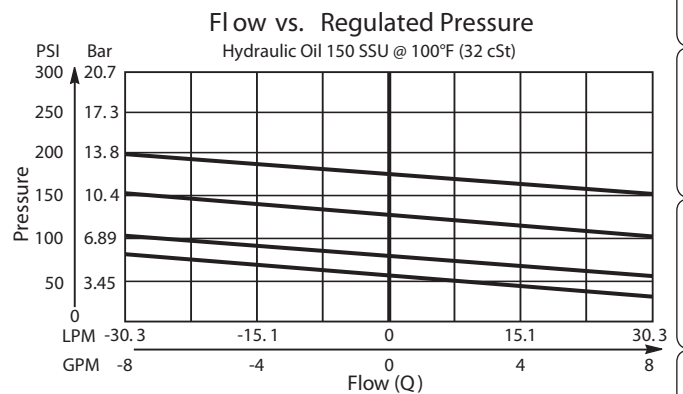

CV
Check Valves

SH
Shuttle Valves

LM
Load/Motor Controls

FC
Flow Controls

PC
Pressure Controls

LE
Logic Elements

DC
Directional Controls

SV
Solenoid Valves

PV
Proportional Valves

CE
Coils & Electronics

BC
Bodies & Cavities

TD
Technical Data

Dimensions Millimeters (Inches)

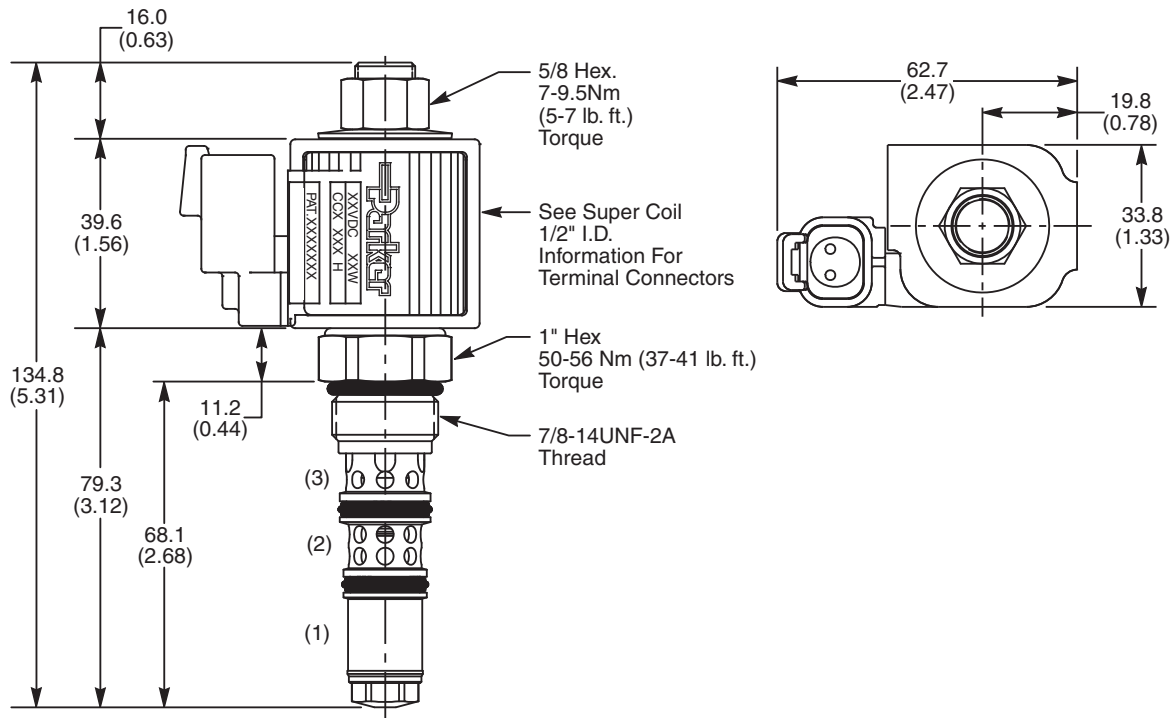

Ordering Information

EPR111	C	
11 Size Proportional Red./Rel. Valve	Style	Pressure Range

Highlighted represents preferred options that offer the shortest lead times. Other options may be available, but at extended lead times.

Coil(s) sold separately. Please see section CE of this catalog, 1/2" Super-Coil (CC series), for ordering information.

*Order Bodies Separately
See section BC*

Code	Style
C	Normally Closed, Pilot Operated

Code	Seals
Omit	"D"-Ring

B10	—	3	—	8T
10 size		3-Way Cavity		Port Size

Code	Pressure Range
10	68.9 Bar (1000 PSI)
20	138 Bar (2000 PSI)
30	207 Bar (3000 PSI)

Code	Porting / Body Material
8T	SAE-8 / Steel (5000 PSI)

Kit	Part Number
D-Ring Seal	SK10-3L
Nitrile Seal	SK10-3LN
Fluorocarbon Seal	SK10-3LV



CV
Check Valves
SH
Shuttle Valves
LM
Load/Motor Controls
FC
Flow Controls
PC
Pressure Controls
LE
Logic Elements
DC
Directional Controls
SV
Solenoid Valves
PV
Proportional Valves
CE
Coils & Electronics
BC
Bodies & Cavities
TD
Technical Data

General Description

2 Way, Normally Closed, Proportional Flow Regulator Valve. Pressure Compensated. For additional information see Technical Tips on pages PV2-PV5.

Features

- One piece cartridge housing ensures internal concentricity
- Coil: Waterproof, hermetically sealed, requires no O'Rings; Symmetrical coil can be reversed without affecting performance.
- Nonmagnetic spool and housing assembly
- Factory-adjusted low variation option (Model "L") is available for applications where low variation of flow from valve to valve is essential at a given current.

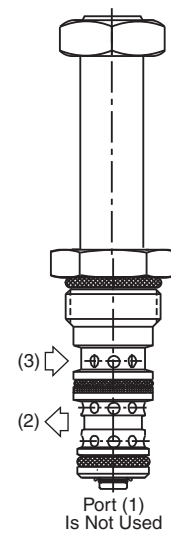
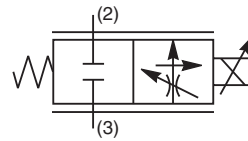
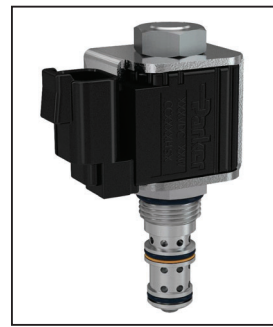

Specifications

Rated Flow	20 7.5 LPM (2 GPM) Low Flow ('SS' Coil) 21 15 LPM (4 GPM) Standard ('SS' Coil) 21 23 LPM (6 GPM) High Flow ('SP' Coil)
Maximum Input Pressure at Port 3	210 Bar (3000 PSI)
Minimum Pressure Differential	20 10.3 Bar (150 PSI) Low Flow 21 13.8 Bar (200 PSI) Standard 21 20.7 Bar (300 PSI) High Flow
Maximum Internal Leakage	570 cc (35 cu. in.) @ 210 Bar (3000 PSI)
Hysteresis @ 100 Hz PWM	<10% (Low Flow and Standard) <3% (High Flow)
Cracking Pressure	25% of Input Signal
Variation of Flow @ 35% of Rated Current	Model "L" ±7% Of Rated Flow
Cartridge Material	All parts steel. All operating parts hardened steel.
Operating Temp. Range/Seals	-34°C to +121°C (Nitrile) (-30°F to +250°F) -26°C to +204°C (Fluorocarbon) (-15°F to +400°F)
Fluid Compatibility/Viscosity	Mineral-based or synthetic with lubricating properties at viscosities of 45 to 2000 SSU (6 to 420 cSt)
Filtration	ISO-4406 18/16/13, SAE Class 4
Approx. Weight	0.08 kg (0.17 lbs.)
Cavity	C08-3 (See BC Section for more details)

Performance Curves

▲ PWM Current Regulator Recommended

Flow vs. Input Current

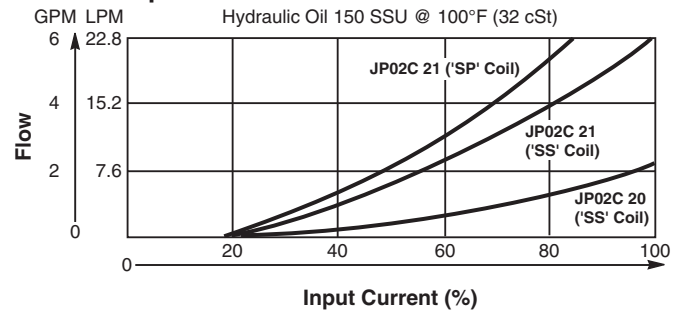

Flow Regulation (Measured 75% of Rated Current)

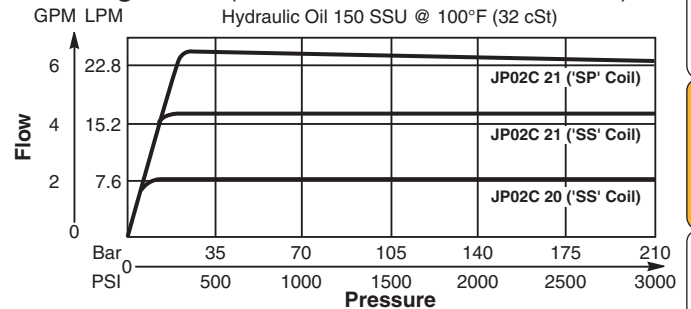

Pressure Drop vs. Flow

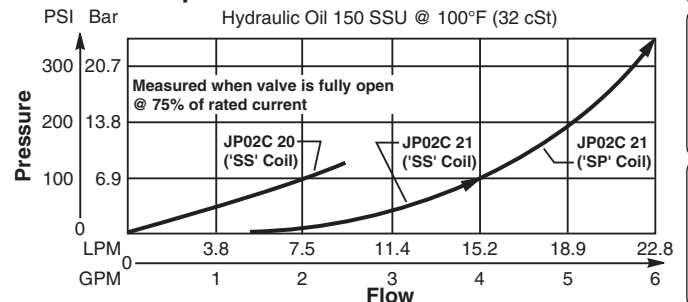

- CV
- Check Valves
- SH
- Shuttle Valves
- LM
- Load/Motor Controls
- FC
- Flow Controls
- PC
- Pressure Controls
- LE
- Logic Elements
- DC
- Directional Controls
- SV
- Solenoid Valves
- PV
- Proportional Valves
- CE
- Coils & Electronics
- BC
- Bodies & Cavities
- TD
- Technical Data

Dimensions Millimeters (Inches)

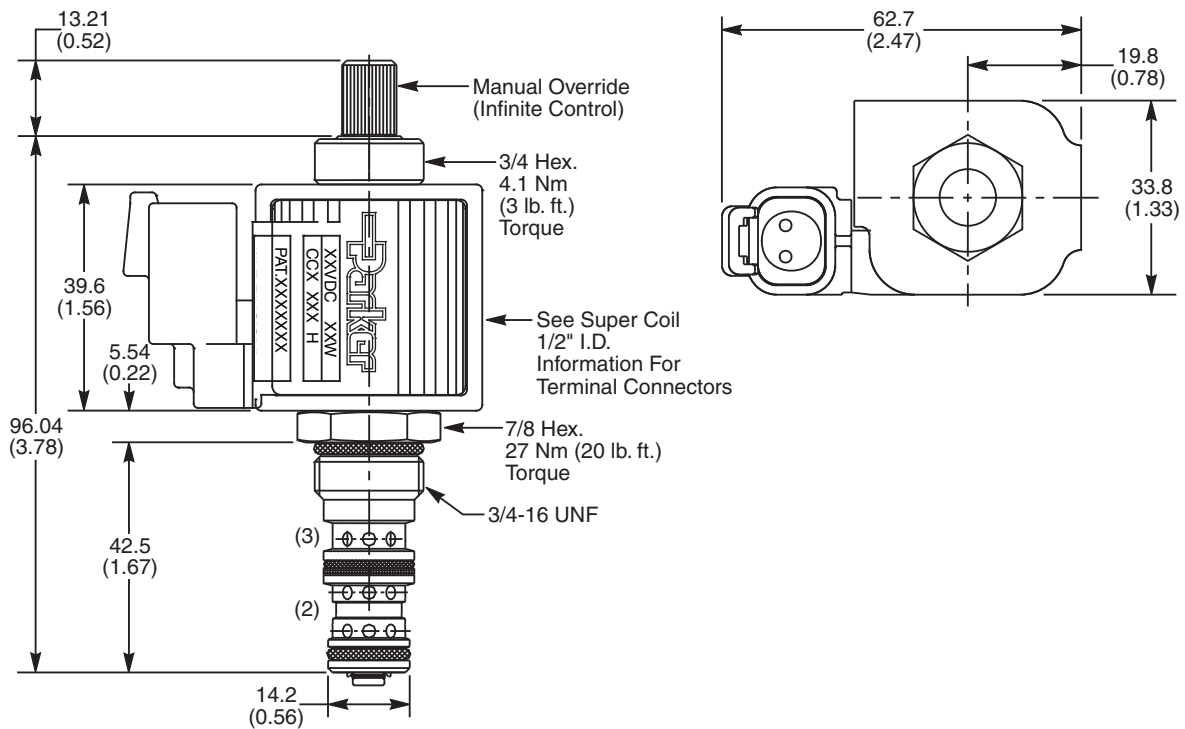

Ordering Information

JP02C				N	L
08 Size Proportional Valve	Style	Override Option	Filter Screen	Seals	Flow Variation

Highlighted represents preferred options that offer the shortest lead times. Other options may be available, but at extended lead times.

Coil(s) sold separately. Please see section CE of this catalog, 1/2" Super-Coil (CC series), for ordering information.

Order Bodies Separately
 See section BC

Code	Style (Maximum Regulated Flow)
20	Low Flow ('SS' Coil) 7.5 LPM (2 GPM)
21	Standard ('SS' Coil) 15 LPM (4 GPM)
21	High Flow ('SP' Coil) 23 LPM (6 GPM)

Code	Seals
N	Nitrile

B08	—	3	—	6T
08 size		3-Way Cavity		Port Size

Code	Porting / Body Material
6T	SAE-6 / Steel (5000 PSI)

Code	Override Option
0	Not Required
5	Infinite Control M.O.

Code	Flow Variation
L	Low Variation (±7% of Rated Flow)

Code	Filter Screen
0	Not Available
1	60 Mesh Screen on Inlet Port

Kit	Part Number
Nitrile Seal	SK30105N-1
Fluorocarbon Seal	SK30105V-1



CV
Check Valves
SH
Shuttle Valves
LM
Load/Motor Controls
FC
Flow Controls
PC
Pressure Controls
LE
Logic Elements
DC
Directional Controls
SV
Solenoid Valves
PV
Proportional Valves
CE
Coils & Electronics
BC
Bodies & Cavities
TD
Technical Data

General Description

2 Way, Normally Closed, Proportional Flow Regulator Valve. Pressure Compensated.
 For additional information see Technical Tips on pages PV2-PV5.

Features

- One piece cartridge housing ensures internal concentricity
- Coil: Waterproof, hermetically sealed, requires no O'Rings; Symmetrical coil can be reversed without affecting performance.
- Nonmagnetic spool and housing assembly
- Factory-adjusted low variation option (Model "L") is available for applications where low variation of flow from valve to valve is essential at a given current.

Specifications

Rated Flow	21 30 LPM (8 GPM) Standard ('SS' Coil) 21 36 LPM (9.5 GPM) High Flow ('SP' Coil)
Maximum Input Pressure at Port 2	210 Bar (3000 PSI)
Minimum Pressure Differential	21 13.8 Bar (200 PSI) Standard 21 20.7 Bar (300 PSI) High Flow
Maximum Internal Leakage	780 cc (46 cu. in.) @ 210 Bar (3000 PSI)
Hysteresis @ 100 Hz PWM	7%
Cracking Pressure	25% of Input Signal
Variation of Flow @ 35% of Rated Current	Model "L" ±7% Of Rated Flow
Cartridge Material	All parts steel. All operating parts hardened steel.
Operating Temp. Range/Seals	-34°C to +121°C (Nitrile) (-30°F to +250°F) -26°C to +204°C (Fluorocarbon) (-15°F to +400°F)
Fluid Compatibility/Viscosity	Mineral-based or synthetic with lubricating properties at viscosities of 45 to 2000 SSU (6 to 420 cSt)
Filtration	ISO-4406 18/16/13, SAE Class 4
Approx. Weight	0.13 kg (0.28 lbs.)
Cavity	3X (See BC Section for more details)

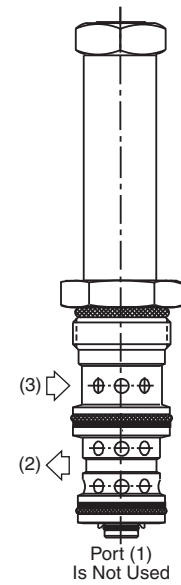
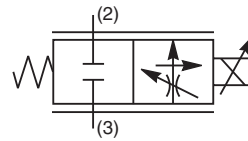
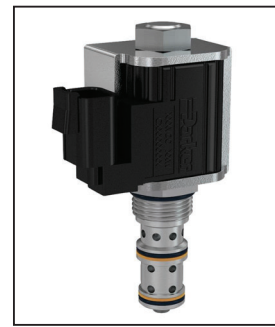

Performance Curves

▲ PWM Current Regulator Recommended

Flow vs. Input Signal

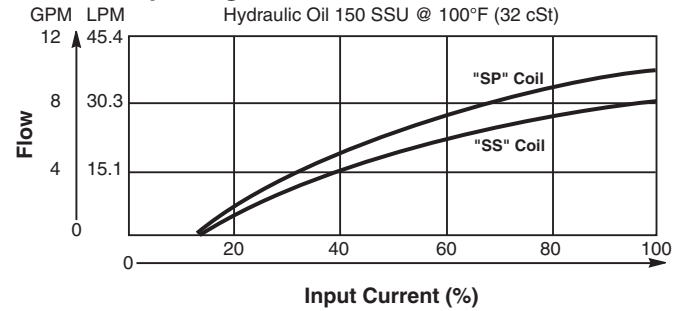

Flow Regulation (Measured 75% of Rated Current)

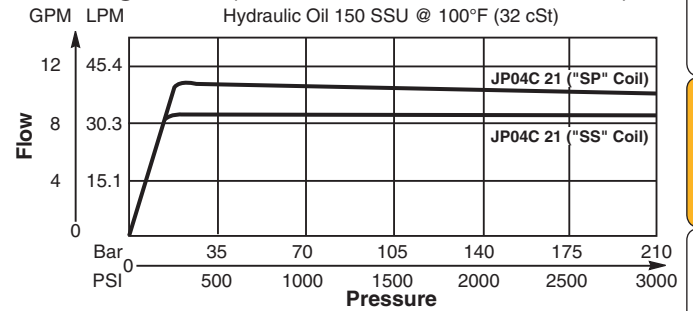

Pressure Drop vs. Flow

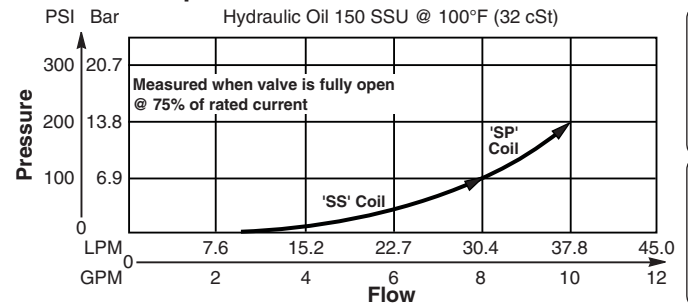

CV	Check Valves
SH	Shuttle Valves
LM	Load/Motor Controls
FC	Flow Controls
PC	Pressure Controls
LE	Logic Elements
DC	Directional Controls
SV	Solenoid Valves
PV	Proportional Valves
CE	Coils & Electronics
BC	Bodies & Cavities
TD	Technical Data

Dimensions Millimeters (Inches)

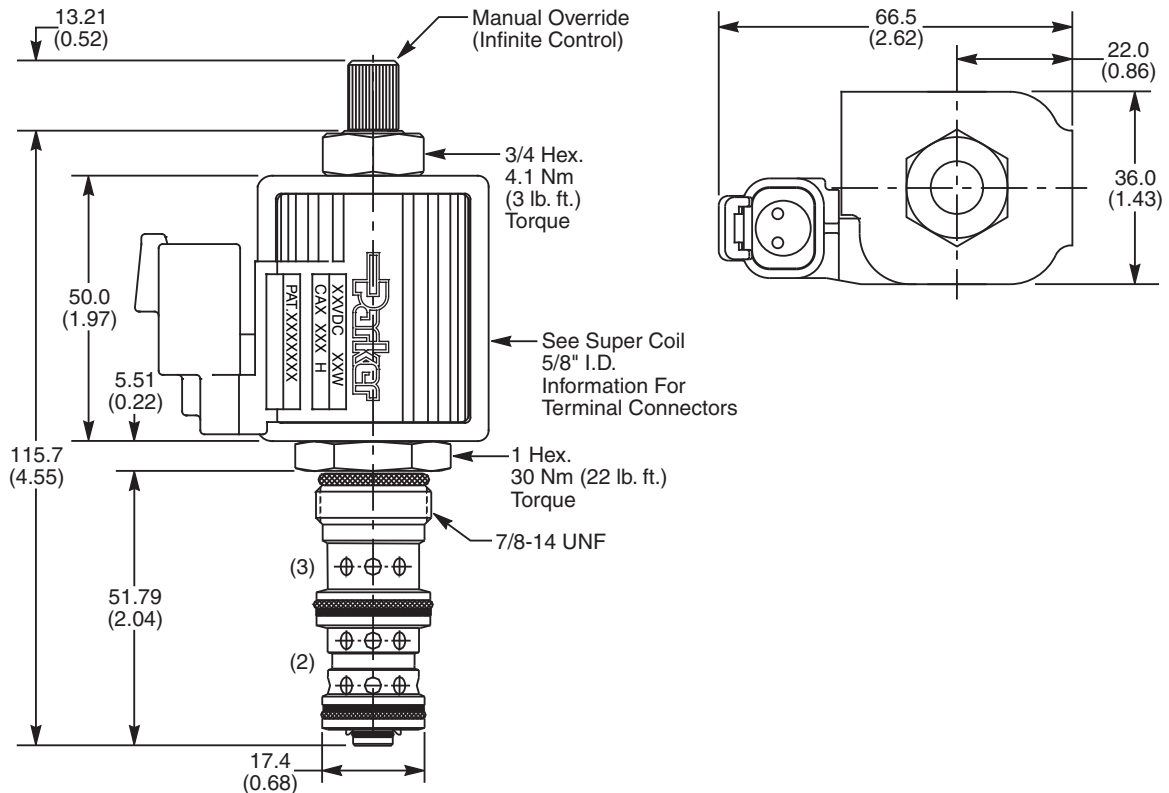

Ordering Information

JP04C	21			N	L
10 Size Proportional Valve	Style	Override Option	Filter Screen	Seals	Flow Variation

Highlighted represents preferred options that offer the shortest lead times. Other options may be available, but at extended lead times.

Coil(s) sold separately. Please see section CE of this catalog, 5/8" Super-Coil (CA series), for ordering information.

Code	Style (Maximum Regulated Flow)
21	Standard ('SS' Coil) 30 LPM (8 GPM)
21	High Flow ('SP' Coil) 36 LPM (9.5 GPM)

Code	Seals
N	Nitrile

Order Bodies Separately
 See section BC

LB10	553	S
Line Body	Porting	Body Material

Code	Override Option
0	Not Required
5	Infinite Control M.O.

Code	Flow Variation
L	Low Variation (±7% of Rated Flow)

Code	Porting
553	1/2" SAE

Code	Filter Screen
0	Not Available
1	60 Mesh Screen on Port 2

Kit	Part Number
Nitrile Seal	SK30106N-1
Fluorocarbon Seal	SK30106V-1

Code	Body Material
S	Steel (5000 PSI)



CV
Check Valves

SH
Shuttle Valves

LM
Load/Motor Controls

FC
Flow Controls

PC
Pressure Controls

LE
Logic Elements

DC
Directional Controls

SV
Solenoid Valves

PV
Proportional Valves

CE
Coils & Electronics

BC
Bodies & Cavities

TD
Technical Data

General Description

2 Way, Normally Open, Proportional Flow Regulator Valve. Pressure Compensated.
 For additional information see Technical Tips on pages PV2-PV5.

Features

- One piece cartridge housing ensures internal concentricity
- Coil: Waterproof, hermetically sealed, requires no O'Rings; Symmetrical coil can be reversed without affecting performance.
- Nonmagnetic spool and housing assembly
- Factory-adjusted low variation option (Model "L") is available for applications where low variation of flow from valve to valve is essential at a given current.

Specifications

Rated Flow	20 9.5 LPM (2.5 GPM) Standard ('SS' Coil) 21 19 LPM (5 GPM) High Flow ('SP' Coil)
Maximum Input Pressure at Port 2	210 Bar (3000 PSI)
Minimum Pressure Differential	20 10.3 Bar (150 PSI) Standard 21 20.7 Bar (300 PSI) High Flow
Maximum Internal Leakage	570 cc (35 cu. in.) @ 210 Bar (3000 PSI)
Hysteresis @ 100 Hz PWM	<3%
Cracking Pressure	25% of Input Signal
Variation of Flow @ 35% of Rated Current	Model "L" ±7% Of Rated Flow
Cartridge Material	All parts steel. All operating parts hardened steel.
Operating Temp. Range/Seals	-34°C to +121°C (Nitrile) (-30°F to +250°F) -26°C to +204°C (Fluorocarbon) (-15°F to +400°F)
Fluid Compatibility/Viscosity	Mineral-based or synthetic with lubricating properties at viscosities of 45 to 2000 SSU (6 to 420 cSt)
Filtration	ISO-4406 18/16/13, SAE Class 4
Approx. Weight	0.08 kg (0.17 lbs.)
Cavity	C08-3 (See BC Section for more details)

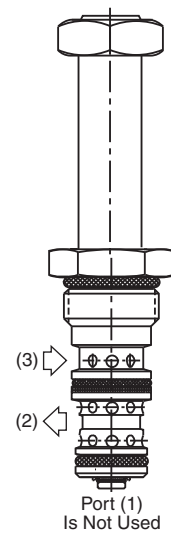
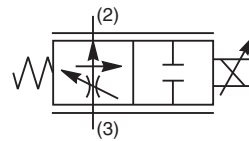

Performance Curves

▲ PWM Current Regulator Recommended

Flow vs. Input Current

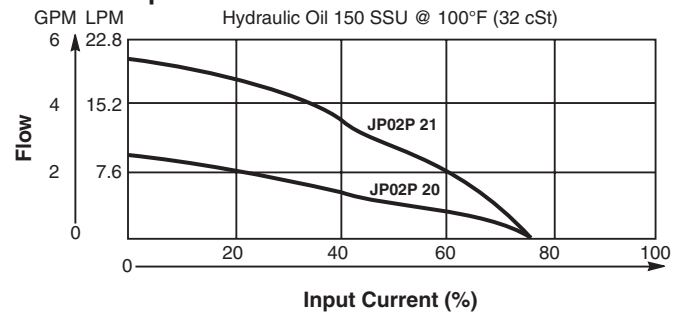

Flow Regulation (Measured 75% of Rated Current)

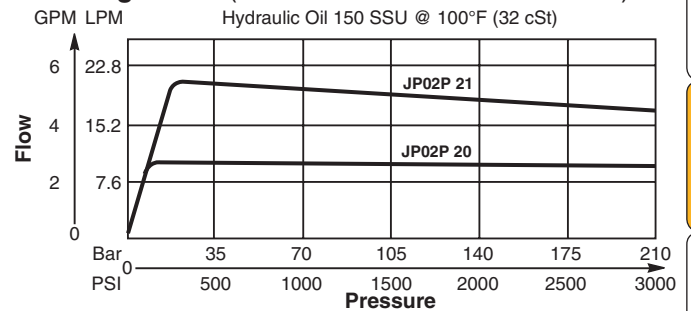

Pressure Drop vs. Flow

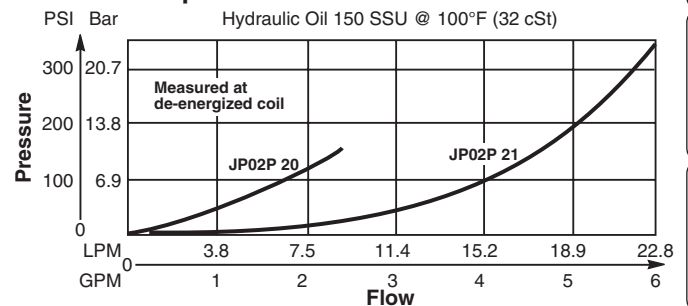

- CV Check Valves
- SH Shuttle Valves
- LM Load/Motor Controls
- FC Flow Controls
- PC Pressure Controls
- LE Logic Elements
- DC Directional Controls
- SV Solenoid Valves
- PV Proportional Valves
- CE Coils & Electronics
- BC Bodies & Cavities
- TD Technical Data

Dimensions Millimeters (Inches)

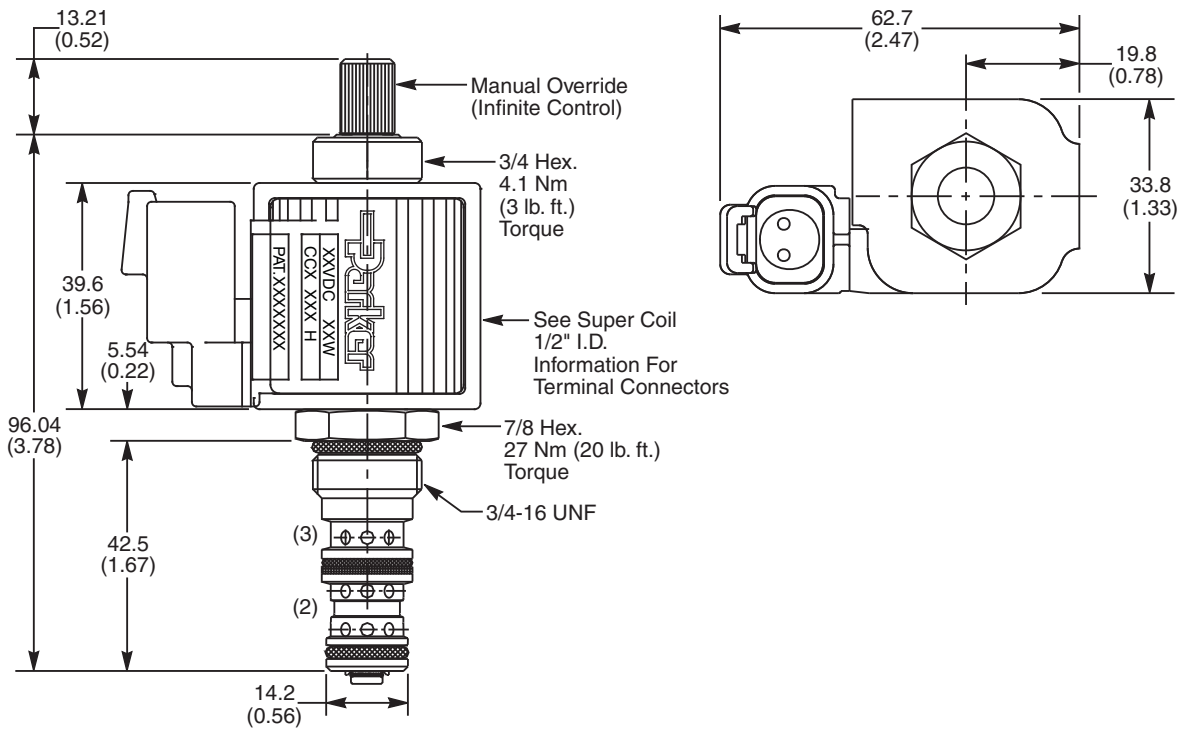

Ordering Information

JP02P				N	L
08 Size Proportional Valve	Style	Override Option	Filter Screen	Seals	Flow Variation

Highlighted represents preferred options that offer the shortest lead times. Other options may be available, but at extended lead times.

Coil(s) sold separately. Please see section CE of this catalog, 1/2" Super-Coil (CC series), for ordering information.

Code	Style (Maximum Regulated Flow)
20	Standard ('SS' Coil) 9.5 LPM (2.5 GPM)
21	High Flow ('SP' Coil) 19 LPM (5 GPM)

Code	Seals
N	Nitrile

Order Bodies Separately
 See section BC

B08	—	3	—	6T
08 size		3-Way Cavity		Port Size

Code	Override Option
0	Not Required
5	Infinite Control M.O.

Code	Flow Variation
L	Low Variation (±7% of Rated Flow)

Code	Porting / Body Material
6T	SAE-6 / Steel (5000 PSI)

Code	Filter Screen
0	Not Available
1	60 Mesh Screen on Port 2

Kit	Part Number
Nitrile Seal	SK30105N-1
Fluorocarbon Seal	SK30105V-1



CV
Check Valves
SH
Shuttle Valves
LM
Load/Motor Controls
FC
Flow Controls
PC
Pressure Controls
LE
Logic Elements
DC
Directional Controls
SV
Solenoid Valves
PV
Proportional Valves
CE
Coils & Electronics
BC
Bodies & Cavities
TD
Technical Data

General Description

3 Way, Normally Closed, Proportional Flow Regulator Valve. Pressure Compensated. For additional information see Technical Tips on pages PV2-PV5.

Features

- Analog proportional pressure compensated flow control valve regulates flow proportionally to the input solenoid current
- One piece cartridge housing ensures internal concentricity
- Coil: Waterproof, hermetically sealed, requires no O'Rings; Symmetrical coil can be reversed without affecting performance.
- Nonmagnetic spool and housing assembly
- Factory-adjusted low variation option (Model "L") is available for applications where low variation of flow from valve to valve is essential at a given current.

Specifications

Rated Inlet Flow	60 LPM (16 GPM)
Rated Regulated Flow	31 26 LPM (7 GPM) Standard ('SS' Coil) 31 30 LPM (8 GPM) High Flow ('SP' Coil)
Maximum Input Pressure at Port 3	210 Bar (3000 PSI)
Minimum Pressure Differential	31 13.8 Bar (200 PSI) Standard 31 20.7 Bar (300 PSI) High Flow
Maximum Internal Leakage	780 cc (46 cu. in.) @ 210 Bar (3000 PSI)
Hysteresis @ 100 Hz PWM	7%
Opening Point	Standard 21% of Nominal Amperage High Flow 17% of Nominal Amperage
Variation of Opening Point	Model "L" ±20% of Amperage
Cartridge Material	All parts steel. All operating parts hardened steel.
Operating Temp. Range/Seals	-34°C to +121°C (Nitrile) (-30°F to +250°F) -26°C to +204°C (Fluorocarbon) (-15°F to +400°F)
Fluid Compatibility/Viscosity	Mineral-based or synthetic with lubricating properties at viscosities of 45 to 2000 SSU (6 to 420 cSt)
Filtration	ISO-4406 18/16/13, SAE Class 4
Approx. Weight	0.14 kg (0.31 lbs.)
Cavity	4C (See BC Section for more details)

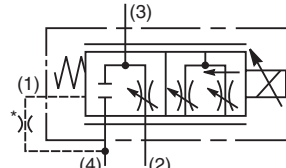
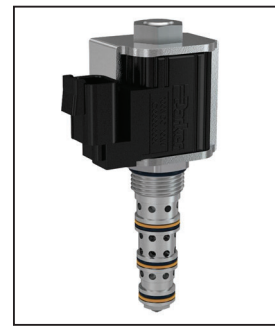

*Always connect Port (1) to Port (4) through .039" orifice.

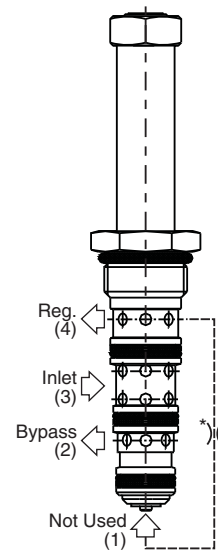

Performance Curves

▲ PWM Current Regulator Recommended

Pressure Compensation of Regulated Flow (Port 4)

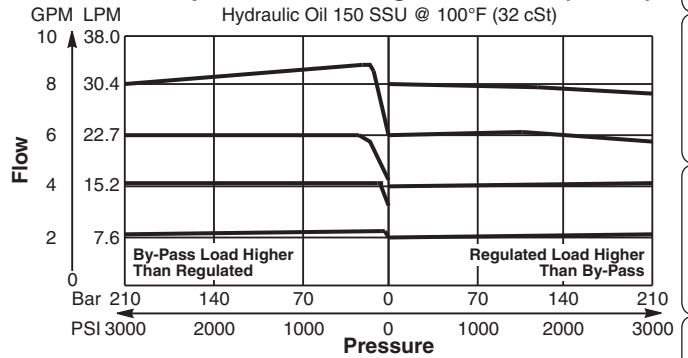

Regulated Flow vs. Input Current Stabilized

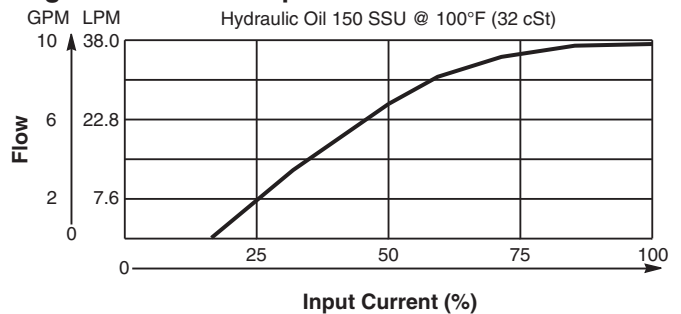

Pressure Drop vs. Flow at Coil Fully Energized

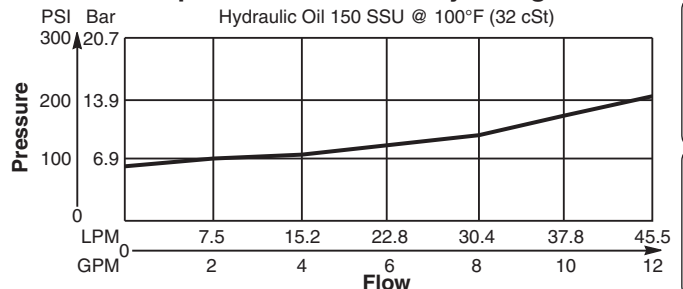

- CV Check Valves
- SH Shuttle Valves
- LM Load/Motor Controls
- FC Flow Controls
- PC Pressure Controls
- LE Logic Elements
- DC Directional Controls
- SV Solenoid Valves
- PV Proportional Valves
- CE Coils & Electronics
- BC Bodies & Cavities
- TD Technical Data

Dimensions Millimeters (Inches)

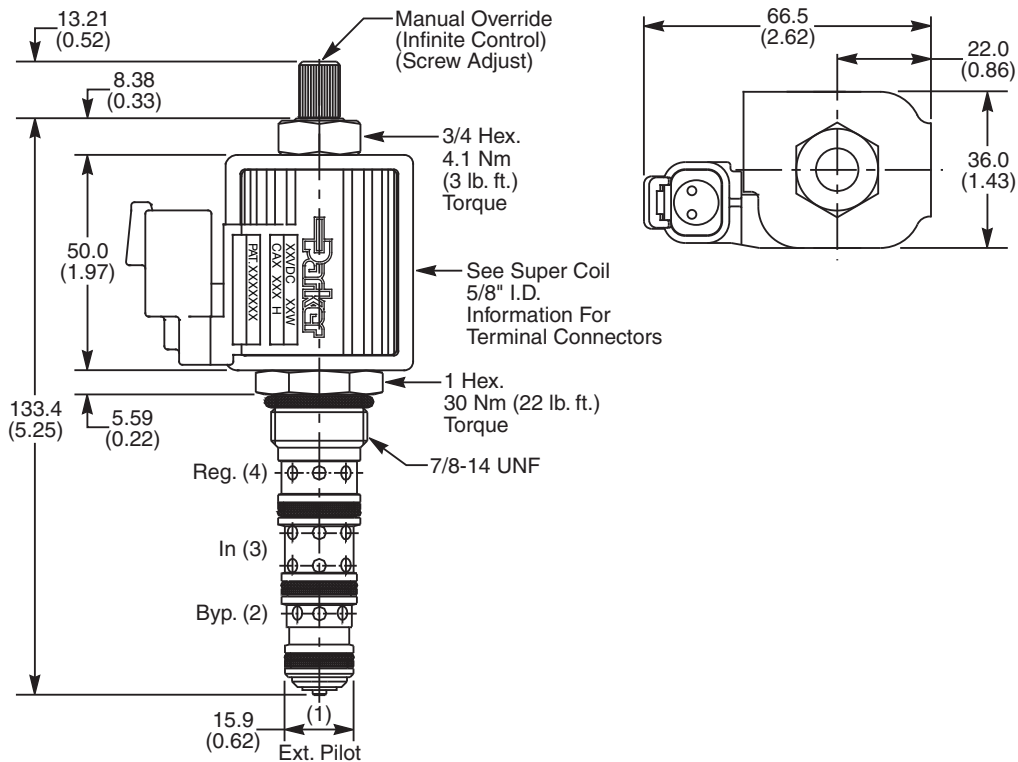

Ordering Information

JP04C	31		0	N	L
10 Size Proportional Valve	Style	Override Option	Filter Screen	Seals	Flow Variation

Highlighted represents preferred options that offer the shortest lead times. Other options may be available, but at extended lead times.

Coil(s) sold separately. Please see section CE of this catalog, 5/8" Super-Coil (CA series), for ordering information.

Code	Style (Maximum Regulated Flow)
31	Standard ('SS' Coil) 26 LPM (7 GPM)
31	High Flow ('SP' Coil) 30 LPM (8 GPM)

Code	Seals
N	Nitrile

Order Bodies Separately
 See section BC

LB10	562	S
Line Body	Porting	Body Material

Code	Override Option
0	Not Required
5	Screw Adjust (Infinite Control)

Code	Flow Variation
L	Low Variation (±7% of Rated Flow)

Code	Porting
562	1/2" SAE Steel (5000 PSI)

Code	Filter Screen
0	Not Available

Kit	Part Number
Nitrile Seal	SK30082N-1
Fluorocarbon Seal	SK30082V-1



CV
Check Valves

SH
Shuttle Valves

LM
Load/Motor Controls

FC
Flow Controls

PC
Pressure Controls

LE
Logic Elements

DC
Directional Controls

SV
Solenoid Valves

PV
Proportional Valves

CE
Coils & Electronics

BC
Bodies & Cavities

TD
Technical Data

General Description

4 Way, 3 Position, Proportional Directional Control Valve. Closed Center Spool. For additional information see Technical Tips on pages PV2-PV5.

Features

- One piece cartridge housing ensures internal concentricity
- Coil: Waterproof, hermetically sealed, requires no O'Rings; Symmetrical coil can be reversed without affecting performance.

Specifications

Operating Pressure	Ports 2, 3 and 4 350 Bar (5000 PSI) Port 1 210 Bar (3000 PSI)
Hysteresis @ 100 Hz PWM	<6%
Cracking Flow	25% to 30% of Input Signal
Variation of Flow	±15% @ 75% of Nominal Current and Constant ΔP Maintained by Pressure Compensator
Port to Port Leakage	10 cu. in./min @ 3000 PSI
Step Response Time at 75% of Amps	On 50 ms Off 40 ms
Cartridge Material	All parts steel. All operating parts hardened steel.
Operating Temp. Range/Seals	-34°C to +121°C (Nitrile) (-30°F to +250°F) -26°C to +204°C (Fluorocarbon) (-15°F to +400°F)
Fluid Compatibility/Viscosity	Mineral-based or synthetic with lubricating properties at viscosities of 45 to 2000 SSU (6 to 420 cSt)
Filtration	ISO-4406 18/16/13, SAE Class 4
Approx. Weight	0.15 kg (0.34 lbs.)
Cavity	C08-4 (See BC Section for more details)

Typical Performance

SPOOL TYPE AND FLOW	RATED FLOW AT 75% OF NOMINAL CURRENT LPM - (GPM)		SUPER COIL TYPE		Compensator ΔP Bar (PSI)
	'a' SOLENOID PUSH P to A, B to T	'b' SOLENOID PULL P to B, A to T	PUSH	PULL	
51 Standard	13.3 - (3.5)	17 - (4.5)	SP	SP	15 (220)
	11.4 - (3.0)	15.2 - (4.0)	SS	SS	15 (220)
52 High Flow	21 - (5.5)	17 - (4.5)	SP	SP	20 (290)
	17.4 - (4.5)	13 - (3.5)	SP	SP	15 (220)

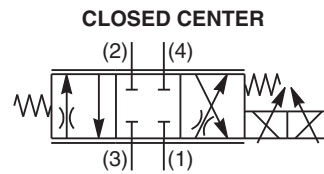
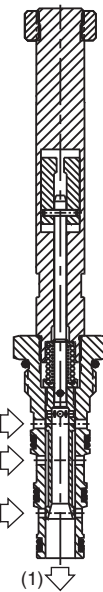

Performance Curves

▲ PWM Current Regulator Recommended

51L With 5 Bar, 75 PSI Compensator
 51 With 15 Bar, 220 PSI Compensator and SS Coil
 Hydraulic Oil 150 SSU @ 100°F (32 cSt)

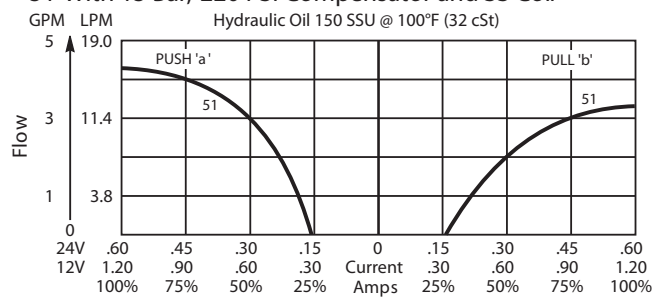

52 With 20 Bar, 290 PSI Compensator and SP Coil
 Hydraulic Oil 150 SSU @ 100°F (32 cSt)

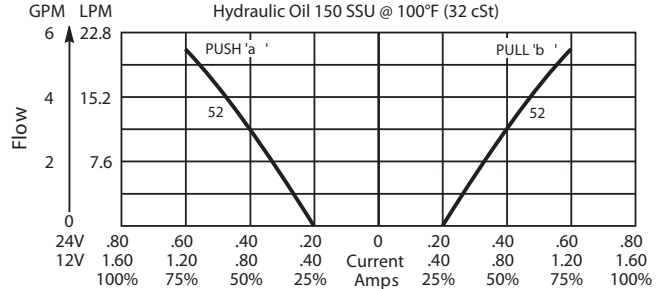

Flow vs. Load

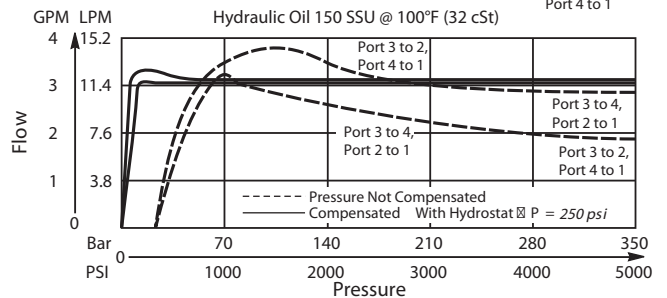

- CV
- Check Valves
- SH
- Shuttle Valves
- LM
- Load/Motor Controls
- FC
- Flow Controls
- PC
- Pressure Controls
- LE
- Logic Elements
- DC
- Directional Controls
- SV
- Solenoid Valves
- PV
- Proportional Valves
- CE
- Coils & Electronics
- BC
- Bodies & Cavities
- TD
- Technical Data

Dimensions Millimeters (Inches)

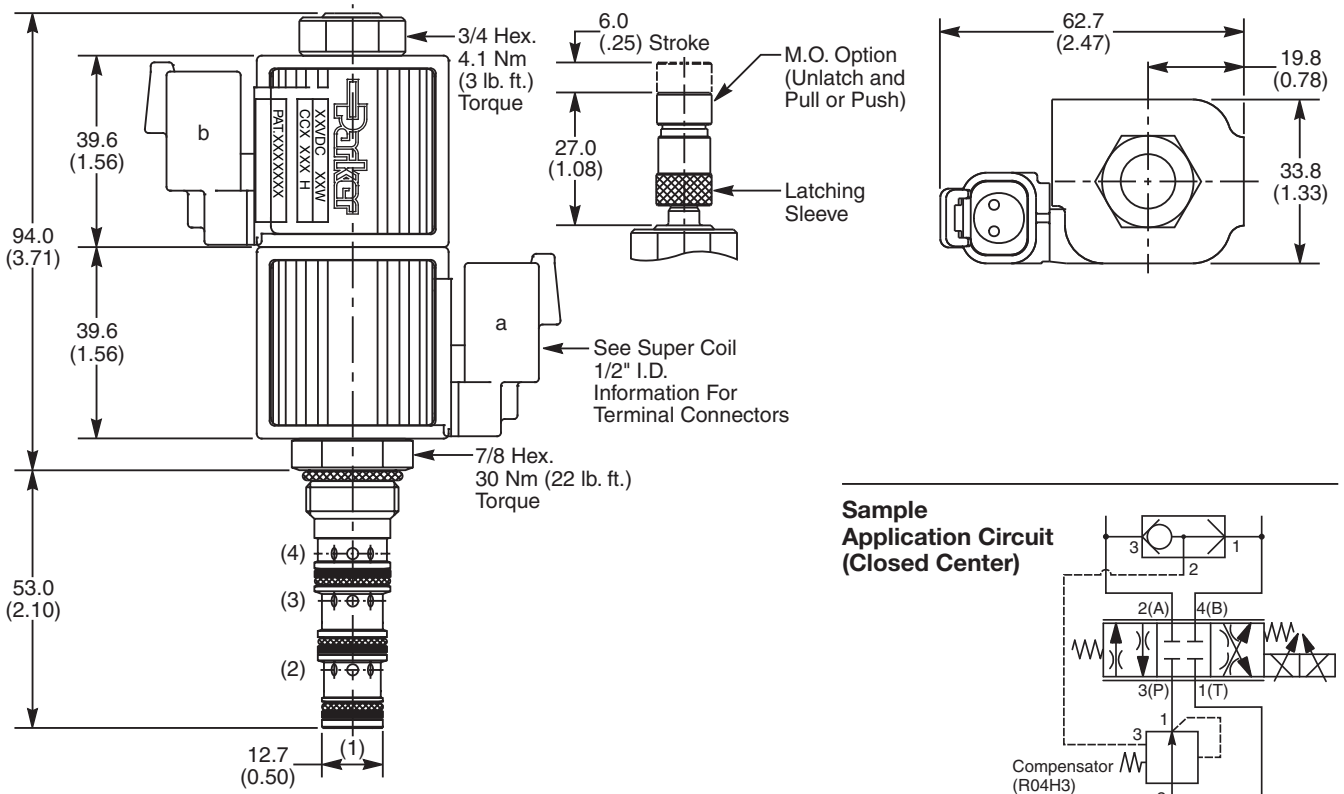

Ordering Information

GP02			N
08 Size Proportional Valve	Style	Override Option	Seals

Highlighted represents preferred options that offer the shortest lead times. Other options may be available, but at extended lead times.

Coil(s) sold separately. Please see section CE of this catalog, 1/2" Super-Coil (CC series), for ordering information.

Code	Style - Floating Center (Flow Pressure and Performance)
51	Standard
52	High Flow

Code	Seals
N	Nitrile

Code	Override Option
0	Not Required
1	Manual Override

Order Bodies Separately
 See section BC

B08	—	4	—	6T
08 size		4-Way Cavity		Port Size

Code	Porting / Body Material
6T	SAE-6 / Steel (5000 PSI)

Kit	Part Number
Nitrile Seal	SK30078N-1
Fluorocarbon Seal	SK30078V-1



General Description

4 Way, 3 Position, Proportional Directional Control Valve. Floating Center Spool. For additional information see Technical Tips on pages PV2-PV5.

Features

- One piece cartridge housing ensures internal concentricity
- Coil: Waterproof, hermetically sealed, requires no O'Rings; Symmetrical coil can be reversed without affecting performance.

Specifications

Operating Pressure	Ports 2, 3 and 4 350 Bar (5000 PSI) Port 1 210 Bar (3000 PSI)
Hysteresis @ 100 Hz PWM	<6%
Cracking Flow	25% to 30% of Input Signal
Variation of Flow	±15% @ 75% of Nominal Current and Constant ΔP Maintained by Pressure Compensator
Port to Port Leakage	10 cu. in/min @ 3000 PSI
Step Response Time at 75% of Amps	On 50 ms Off 40 ms
Cartridge Material	All parts steel. All operating parts hardened steel.
Operating Temp. Range/Seals	-34°C to +121°C (Nitrile) (-30°F to +250°F) -26°C to +204°C (Fluorocarbon) (-15°F to +400°F)
Fluid Compatibility/Viscosity	Mineral-based or synthetic with lubricating properties at viscosities of 45 to 2000 SSU (6 to 420 cSt)
Filtration	ISO-4406 18/16/13, SAE Class 4
Approx. Weight	0.15 kg (0.34 lbs.)
Cavity	C08-4 (See BC Section for more details)

Typical Performance

SPOOL TYPE AND FLOW	RATED FLOW AT 75% OF NOMINAL CURRENT LPM - (GPM)		SUPER COIL TYPE		Compensator ΔP Bar (PSI)
	'a' SOLENOID PUSH P to A, B to T	'b' SOLENOID PULL P to B, A to T	PUSH	PULL	
53 Standard	14 - (3.8)	15 - (4.0)	SP	SP	10 (150)
	9 - (2.5)	10 - (2.7)	SS	SS	5 (75)
54 High Flow	17 - (4.5)	19 - (5.0)	SP	SP	20 (290)
	15 - (4.0)	15 - (4.0)	SS	SS	15 (220)

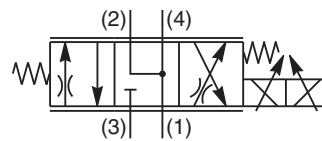
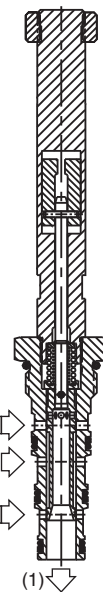

Performance Curves

▲ PWM Current Regulator Recommended

53 and 53L With 5 Bar, 75 PSI Compensator and SS Coil

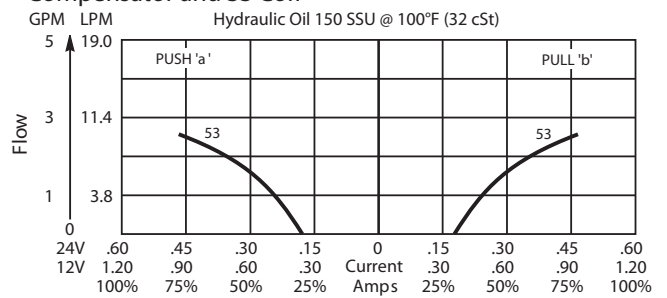

54 With 20 Bar, 290 PSI Compensator and SP Coil

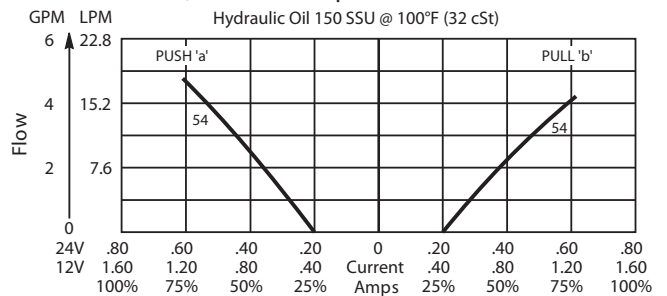

Flow vs. Load

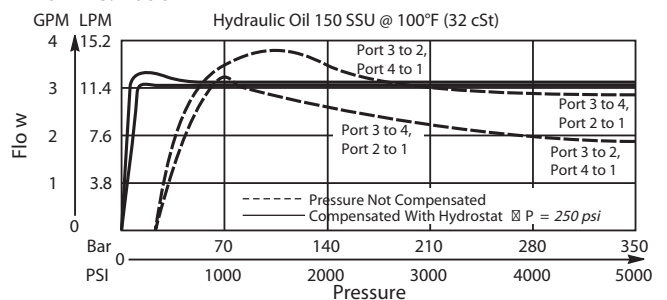

CV
Check Valves

SH
Shuttle Valves

LM
Load/Motor Controls

FC
Flow Controls

PC
Pressure Controls

LE
Logic Elements

DC
Directional Controls

SV
Solenoid Valves

PV
Proportional Valves

CE
Coils & Electronics

BC
Bodies & Cavities

TD
Technical Data

Dimensions Millimeters (Inches)

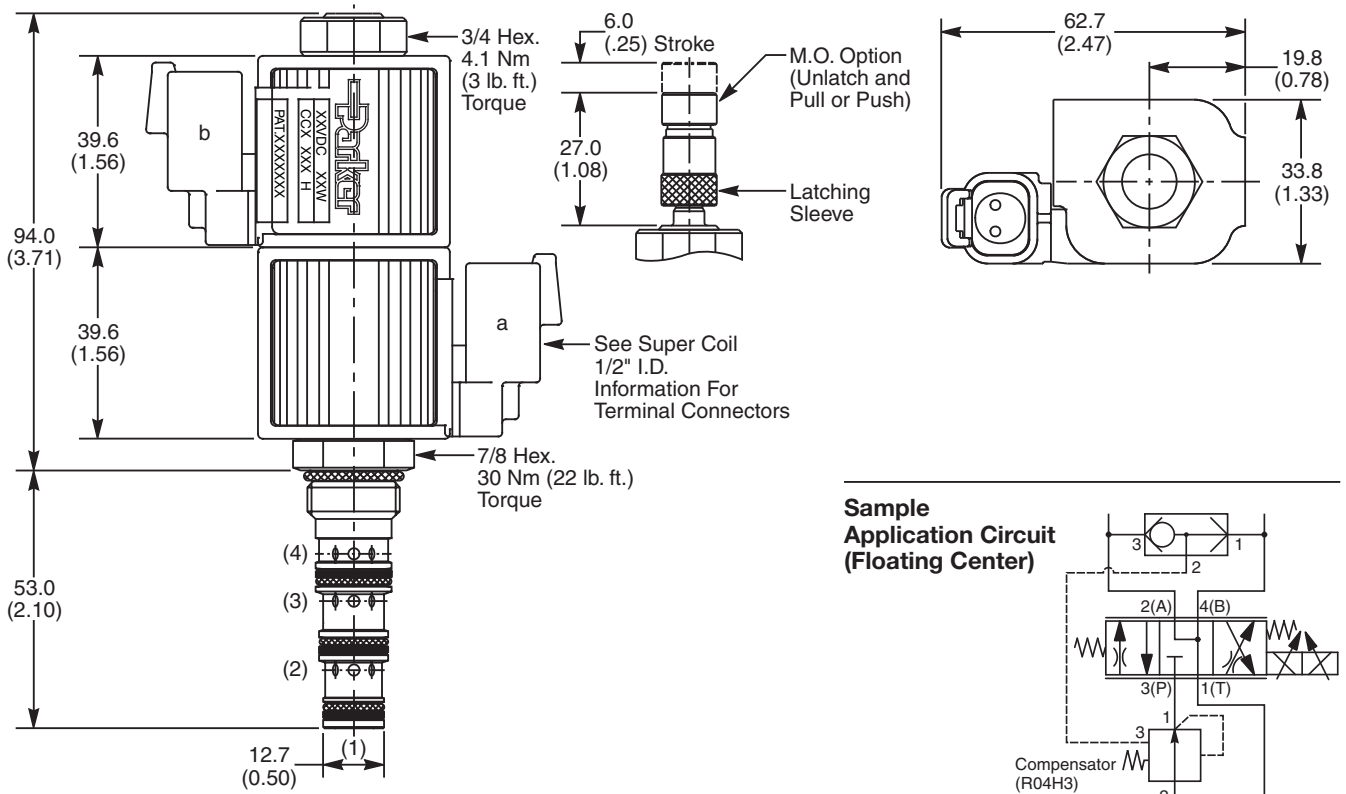

Ordering Information

GP02			N
08 Size Proportional Valve	Style	Override Option	Seals

Highlighted represents preferred options that offer the shortest lead times. Other options may be available, but at extended lead times.

Coil(s) sold separately. Please see section CE of this catalog, 1/2" Super-Coil (CC series), for ordering information.

Code	Style - Floating Center (Flow Pressure and Performance)
53	Standard
54	High Flow

Code	Seals
N	Nitrile

Order Bodies Separately
 See section BC

B08	—	4	—	6T
08 size		4-Way Cavity		Port Size

Code	Porting / Body Material
6T	SAE-6 / Steel (5000 PSI)

Code	Override Option
Omit	Not Required
1	Manual Override

Kit	Part Number
Nitrile Seal	SK30078N-1
Fluorocarbon Seal	SK30078V-1

General Description

4 Way, 3 Position, Proportional Directional Control Valve. Closed Center or Floating Center Spool. For additional information see Technical Tips on pages PV2-PV5.

Features

- One piece cartridge housing ensures internal concentricity
- Coil: Waterproof, hermetically sealed, requires no O'Rings; Symmetrical coil can be reversed without affecting performance.
- All external parts zinc plated

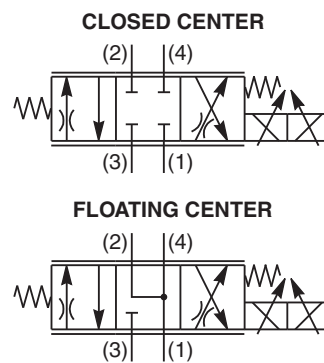
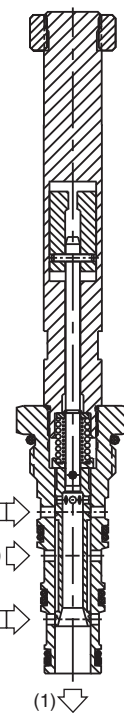
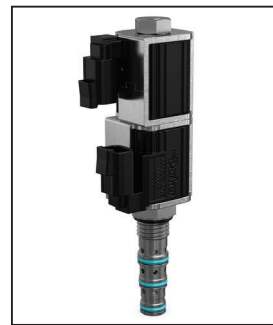

Specifications

Operating Pressure	210 Bar (3000 PSI)
Hysteresis @ 100 Hz PWM	<6%
Cracking Flow	25% to 30% of Input Signal
Variation of Flow	±15% @ 75% of Nominal Current and Constant ΔP Maintained by Pressure Compensator
Port to Port Leakage	10 cu. in. @ 3000 PSI
Step Response Time at 75% of Amps	On 50 ms Off 40 ms
Cartridge Material	All parts steel. All operating parts hardened steel.
Operating Temp. Range/Seals	-37°C to +93°C ("D"-Ring) (-35°F to +200°F) -34°C to +121°C (Nitrile) (-30°F to +250°F) -26°C to +204°C (Fluorocarbon) (-15°F to +400°F)
Fluid Compatibility/Viscosity	Mineral-based or synthetic with lubricating properties at viscosities of 45 to 2000 SSU (6 to 420 cSt)
Filtration	ISO-4406 18/16/13, SAE Class 4
Approx. Weight	0.28 kg (0.57 lbs.)
Cavity	C10-4 (See BC Section for more details)

Sample Application Circuit

Closed Center

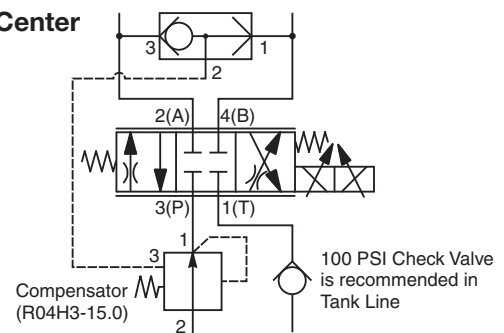

Floating Center

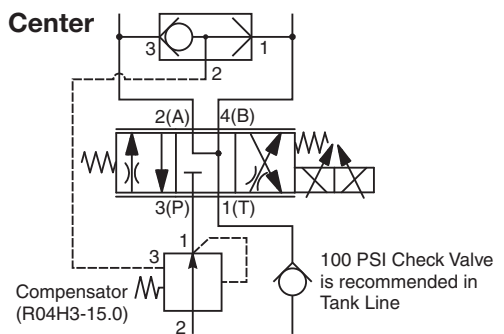

CV
Check Valves

SH
Shuttle Valves

LM
Load/Motor Controls

FC
Flow Controls

PC
Pressure Controls

LE
Logic Elements

DC
Directional Controls

SV
Solenoid Valves

PV
Proportional Valves

CE
Coils & Electronics

BC
Bodies & Cavities

TD
Technical Data

Dimensions Millimeters (Inches)

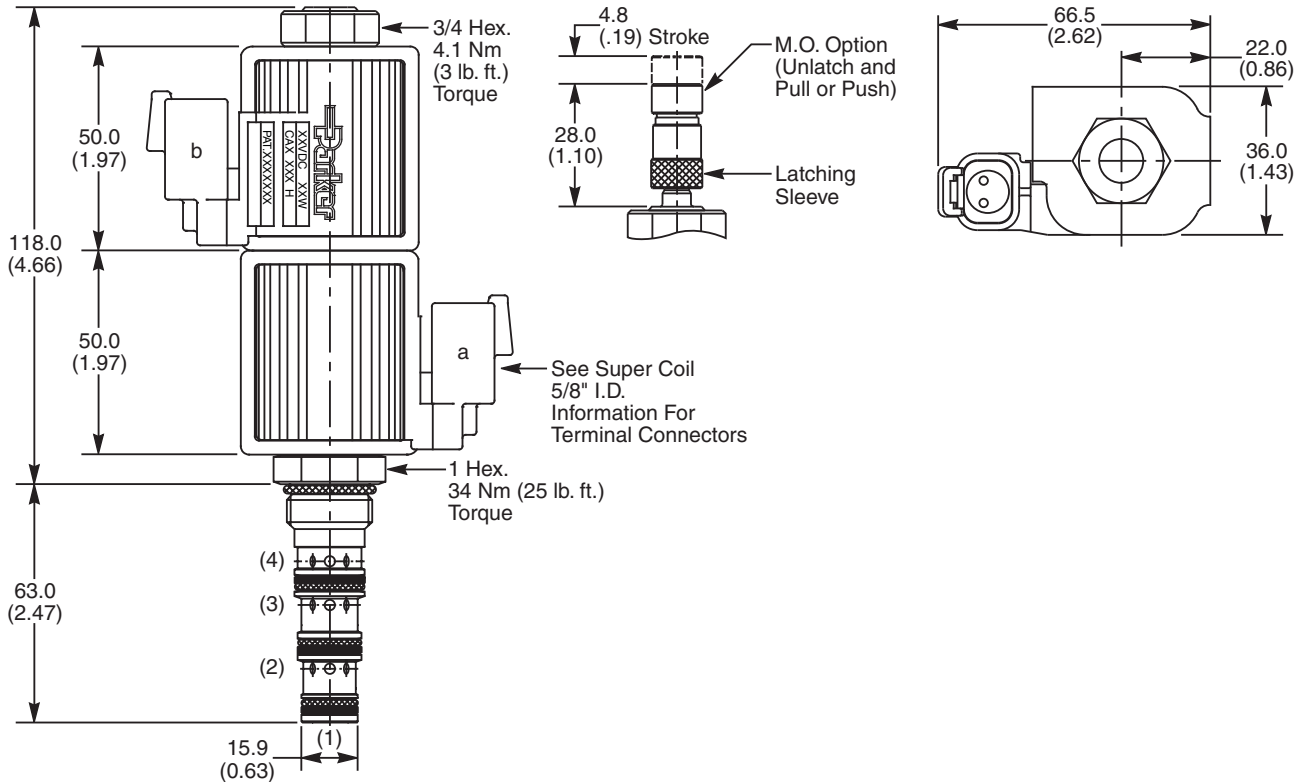

Ordering Information

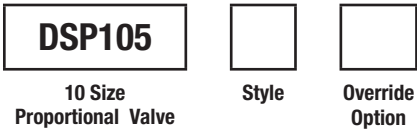

Highlighted represents preferred options that offer the shortest lead times. Other options may be available, but at extended lead times.

Coil(s) sold separately. Please see section CE of this catalog, 5/8" Coil (CA series), for ordering information.

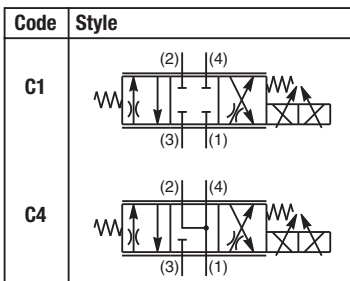

Code	Override Options
Omit	None
M	Push/Pull

Code	Seals
Omit	"D"-Ring

Kit	Part Number
D-Ring Seal	SK10-4
Nitrile Seal	SK10-4
Fluorocarbon Seal	SK10-4V

Order Bodies Separately
 See section BC



Code	Porting / Body Material
8T	SAE-6 / Steel (5000 PSI)



CV
Check Valves

SH
Shuttle Valves

LM
Load/Motor Controls

FC
Flow Controls

PC
Pressure Controls

LE
Logic Elements

DC
Directional Controls

SV
Solenoid Valves

PV
Proportional Valves

CE
Coils & Electronics

BC
Bodies & Cavities

TD
Technical Data

▲ PWM Current Regulator Recommended

C1 With 15 Bar, 220 PSI Compensator and SP Coil

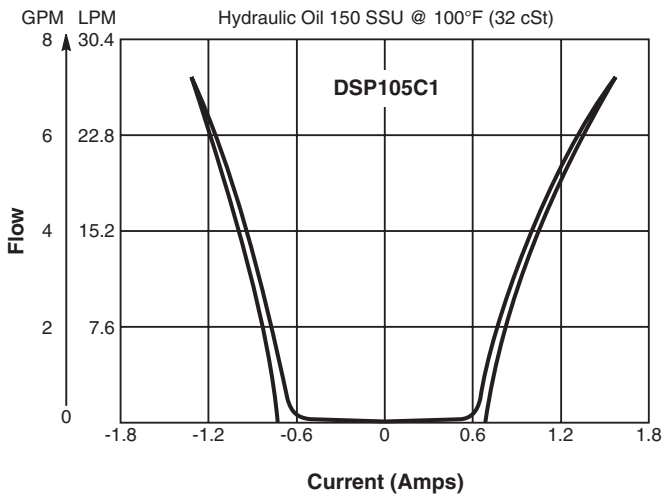

C4 With 15 Bar, 220 PSI Compensator and SP Coil

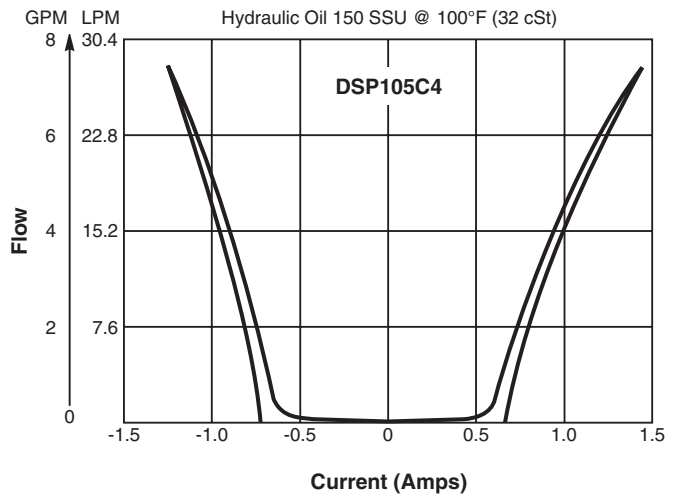

**Pressure Compensation Pull Coil
 Inlet to Work Port**

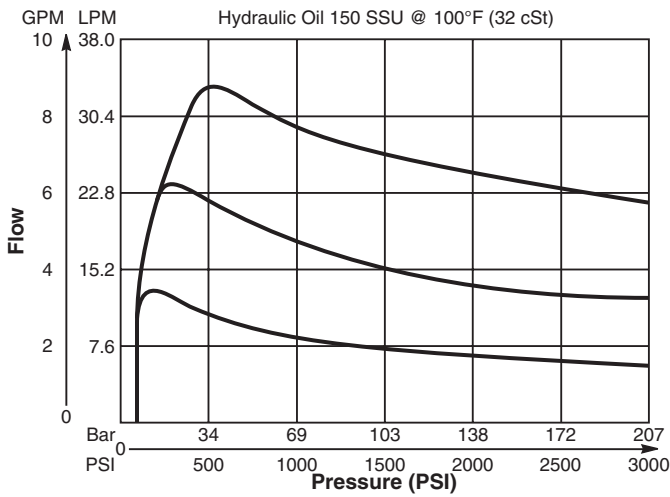

**Pressure Compensation Push Coil
 Inlet to Work Port**

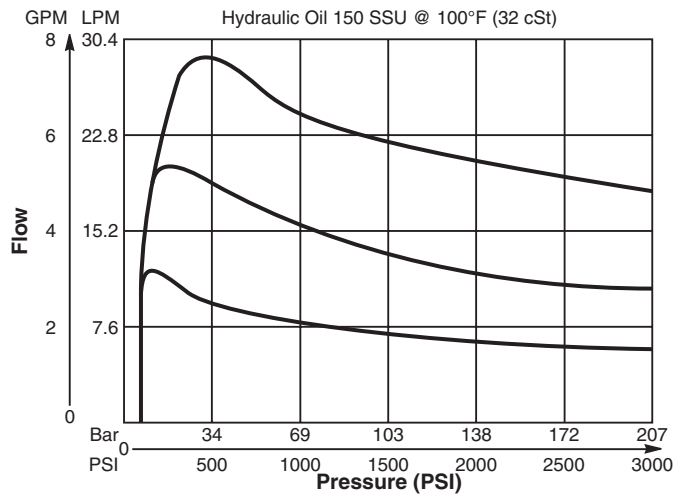

C1 Spool Port 3 to 4

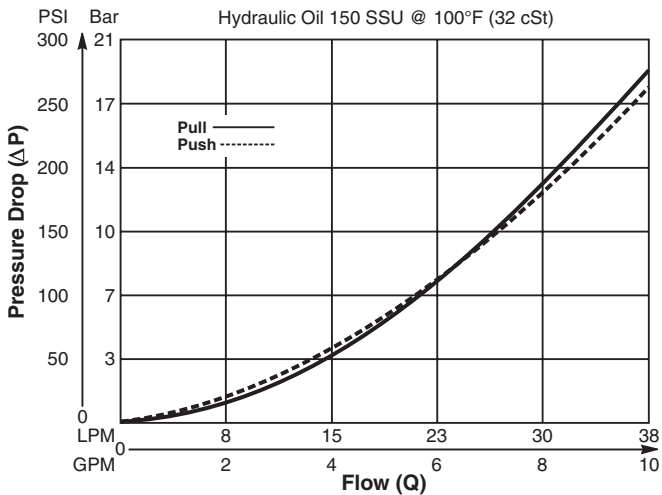

CV
Check Valves
SH
Shuttle Valves
LM
Load/Motor Controls
FC
Flow Controls
PC
Pressure Controls
LE
Logic Elements
DC
Directional Controls
SV
Solenoid Valves
PV
Proportional Valves
CE
Coils & Electronics
BC
Bodies & Cavities
TD
Technical Data

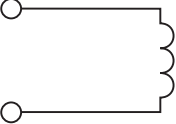
	SERIES	DESCRIPTION	PAGE NO.
	Technical Tips.....		CE2-CE3
	SUPER COILS		
	CC	1/2" Solenoid Tubes	CE4-CE5
	CA.....	5/8" Solenoid Tubes	CE6-CE7
	SW7L.....	1/2" Solenoid Tube - Short.....	CE8- CE9

CV

Check Valves

SH

Shuttle Valves

LM

Load/Motor Controls

FC

Flow Controls

PC

Pressure Controls

LE

Logic Elements

DC

Directional Controls

SV

Solenoid Valves

PV

Proportional Valves

CE

Coils & Electronics

BC

Bodies & Cavities

TD

Technical Data

INTRODUCTION

This technical tips section is designed to help familiarize you with the Parker line of Coils. In this section we highlight the features and discuss some of the available options.

We also use this section to present some common terminology related to coil and coil technology.

COMMON OPTIONS

Below are some of the common options to the Super Coil product offering.

Continuous Duty: Parker’s standard line of coils are rated for continuous duty operation. This means the coil can be left on continuously without fear of the magnet wire insulation breakdown, when used in standard climate conditions. The Super Coils are made of a high quality Class N magnet wire. This Class N rating signifies the internal wires are rated to 200°C (392°F).

Continuous duty does not mean the coil will have the same amount of power after hours of operation as it had at initial actuation. Coils do heat up during use. This internal heat rise increases the resistance of the coil and thus, decreases the current ($V = IR$). The performance curves presented on the solenoid valve pages are based on a coil at room temperature and 85% of voltage. Thus, when using a valve in continuous duty applications, you may need to derate the performance. In short, the continuous duty rating signifies that while the coil will get hot during use and resistance will increase, it will not generate enough heat to damage the coil.

Terminations: Parker offers a wide variety of coil terminations for all coils to meet the demands of your application. Over the years, the dual lead wire and dual spade offerings have been popular due to their ease of installation and availability. In the past few years, the demand for more secure termination connections has increased.

In addition, the integral connectors reduce cost and improve integrity by reducing the number of connections. As such, the DIN, and Integral Deutsch have increased in popularity.

If you do not find your desired coil termination in our catalog, contact your factory sales representative.

Current Types: Both direct current (DC) and alternating current (AC) versions are available for the Parker line of coils. The AC versions are essentially DC coils with a full wave rectifier integrally molded into the coil. The rectifiers are rated for voltage peaks up to 1000 volts maximum. For voltage transients greater than 1000 volts, a Harris Thyrector is recommended. The AC coils operate at 50/60 cycles (Hz). Since the AC versions are rectified DC coils, there is no inrush current like with “true” AC coils. It also means DC coils and AC coils are interchangeable.

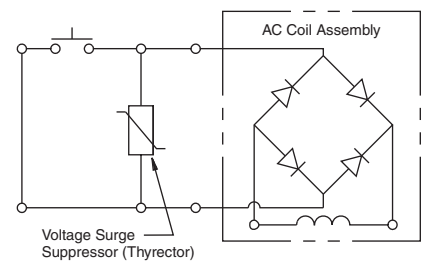

Voltages: Parker has a wide selection of coils available to meet your needs. Most coil terminations are available with our standard voltages of 12, 24 Volts DC and 115 Volts AC. Contact your Parker representative should your application call for voltages other than our standard offering.

Wattages: Parker offers a variety of coil wattages to meet the demands of your application. However, when using Parker valves, please note that all performance curves/values are based on using the higher watt coil. Selecting a lower watt coil could possibly de-rate the performance of the valve. Contact your Parker representative should your application call for wattages other than our standard offering.

CV
Check Valves

SH
Shuttle Valves

LM
Load/Motor Controls

FC
Flow Controls

PC
Pressure Controls

LE
Logic Elements

DC
Directional Controls

SV
Solenoid Valves

PV
Proportional Valves

CE
Coils & Electronics

BC
Bodies & Cavities

TD
Technical Data

Technical Tips

Diodes: The Parker Coils can be ordered with a diode molded internally. The Super Coil (HSZN termination) uses a Zener Diode that is not polarity sensitive. Other Super Coil terminations that can be available with a IN5627 diode are polarity sensitive. Diodes are sometimes used to protect sensitive, downstream electrical components from potential surges from the coil. By internally molding the diode into the coil, you can reduce the assembly time and cost associated with externally wiring a diode. One should be careful not to switch the polarity (“+” and “-” terminals), when wiring a coil with an internal diode. If these terminals are switched, the first time voltage is applied to the coil; the short circuit will destroy the diode and render the coil use-less.

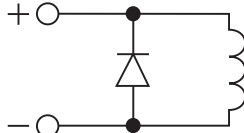

Parker coils with diodes have “+” and “-” molded near the termination outlet to help identify polarity.

Coils and Electronics

DIN Connectors: Parker does offer connectors for use with the DIN style coils. As shown below, the DIN connectors are available in both rectified and non-rectified forms. The cable gland versions can be ordered for type PG9 or PG11.

Cable Gland

Type	Non-Rectified	Rectified
PG9	710549-00	712126-01
PG11	710549-01	712126-00

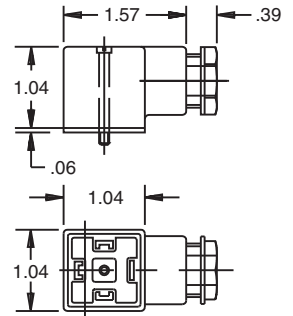

Conduit

Rectified
712704-00

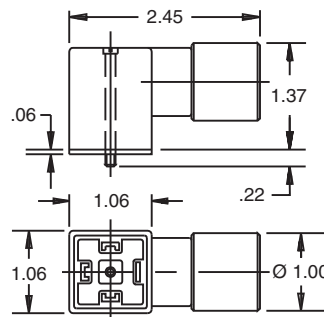

Conduit

Non-Rectified
710549-02

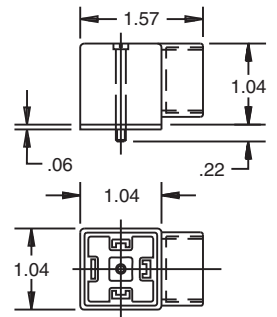

CV	Check Valves
SH	Shuttle Valves
LM	Load/Motor Controls
FC	Flow Controls
PC	Pressure Controls
LE	Logic Elements
DC	Directional Controls
SV	Solenoid Valves
PV	Proportional Valves
CE	Coils & Electronics
BC	Bodies & Cavities
TD	Technical Data

Features

- Integral Deutsch connector coil exceeds IP69K standards
- Integral Deutsch connector coil thermal shock dunk test rated
- Universal 50/60 Hz operation
- Waterproof coil hermetically sealed, requires no O-rings or waterproofing kits
- External plated steel flux-carrying band (unlike encapsulated band) enables coil to withstand severe thermal shocks without cracking
- Symmetrical coil can be reversed without affecting performance

Specifications

Coil Type	S Standard P Puissant
Nominal Wattage (See Ordering Information For Exact Wattage)	S 14 Watts P 19 Watts
Duty Cycle	Continuous @ 100% voltage
Magnetic Wire Insulation Class	'N' Rated at 200°C (392°F)
Temperature Range	-40°C to +200°C (-40°F to +392°F)
Temperature Rise At Nominal Voltage And Natural Ventilation	S 75°C (135°F) P 95°C (172°F)
Dielectric Strength Maximum Current Leakage (Amps)	.0005 In dry lab condition at 1000V AC for 30 seconds .001 After being immersed in 23°C (77°F) water with waterproof connector for 24 hours at 500V AC
Encapsulating Material	Glass filled rynite
Color Identification On The Terminal Boss	S Black Ring P Red Ring
Weight	0.20 kg (0.44 lbs.)

AC Coil Assembly

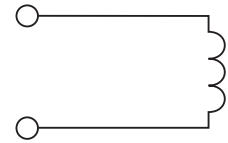
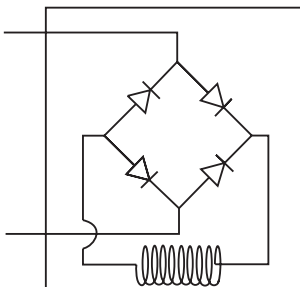

Ordering Information

CC Super Coil 1/2" I.D.

Wattage Voltage Termination

Code	Wattage
S	Standard
P	Puissant

Code	Voltage	Watts		Amps		Ohms**	
		S	P	S	P	S	P
		Volts					
012*	12 VDC	14	19	1.15	1.58	10.43	7.58
024*	24 VDC	14	19	0.58	0.79	41.74	30.30
115*	115 VAC	16	19	0.17	0.20	680	576

*Standard Voltages **Resistance ±10% at 68°F

Code	Termination
*D	DIN 43650 (AC or DC, Supplied without DIN Connector)
*HSN	Integral Deutsch with Anti-vibration ring (DC Only)
*HSZN	Integral Deutsch with Anti-vibration ring and Zener Diode (DC Only) *Zener Diode for use with on/off solenoid valves and not recommended for proportional valves.

***UL Listed**
 Note: Additional voltages and other terminals may be available. For details please consult factory.
 DIN Female Mating Connector: See page CE3
 Deutsch Mating Connector: # DT06-2S

CV
Check Valves

SH
Shuttle Valves

LM
Load/Motor Controls

FC
Flow Controls

PC
Pressure Controls

LE
Logic Elements

DC
Directional Controls

SV
Solenoid Valves

PV
Proportional Valves

CE
Coils & Electronics

BC
Bodies & Cavities

TD
Technical Data

Terminal Styles and Dimensions

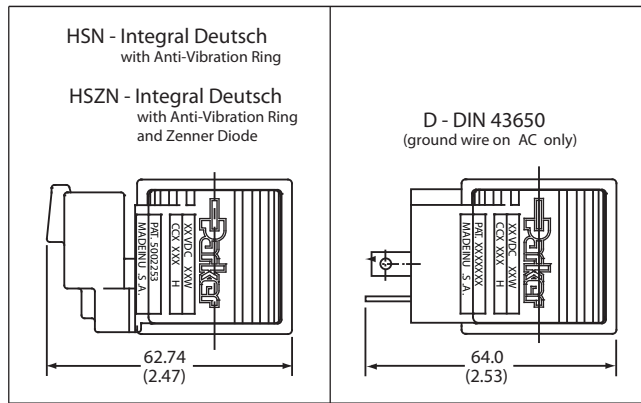
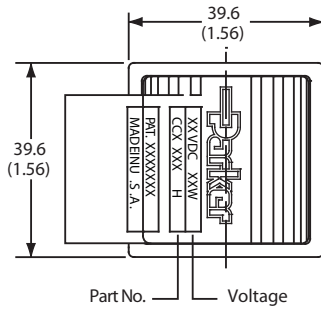
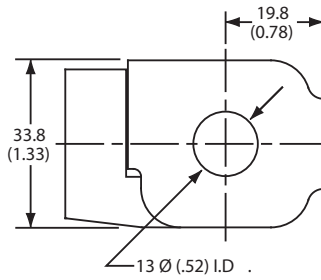

NOTES:

1. The standard A.C. coil includes a molded-in full wave rectifier rated for 800 peak reverse voltage.
2. All P Puissant (high wattage) coils use a red ring as an indication marker on the terminal boss.



CV
Check Valves
SH
Shuttle Valves
LM
Load/Motor Controls
FC
Flow Controls
PC
Pressure Controls
LE
Logic Elements
DC
Directional Controls
SV
Solenoid Valves
PV
Proportional Valves
CE
Coils & Electronics
BC
Bodies & Cavities
TD
Technical Data

Features

- Integral Deutsch connector coil exceeds IP69K standards
- Integral Deutsch connector coil thermal shock dunk test rated
- Universal 50/60 Hz operation
- Coil hermetically sealed, requires no O-rings or waterproofing kits
- External plated steel flux-carrying band (unlike encapsulated band) enables coil to withstand severe thermal shocks without cracking
- Symmetrical coil can be reversed without affecting performance

Specifications

Coil Type	S Standard P Puissant
Nominal Wattage (See Ordering Information For Exact Wattage)	S 18 Watts P 28 Watts
Duty Cycle	Continuous @ 100% voltage
Magnetic Wire Insulation Class	'N' Rated at 200°C (392°F)
Temperature Range	-40°C to +200°C (-40°F to +392°F)
Temperature Rise At Nominal Voltage And Natural Ventilation	S 75°C (135°F) P 95°C (172°F)
Dielectric Strength Maximum Current Leakage (Amps)	.0005 In dry lab condition at 1000V AC for 30 seconds .001 After being immersed in 23°C (77°F) water with waterproof connector for 24 hours at 500V AC
Encapsulating Material	Glass filled rynite
Color Identification On The Terminal Boss	S Black Ring P Red Ring
Weight	0.29 kg (0.64 lbs.)

AC Coil Assembly

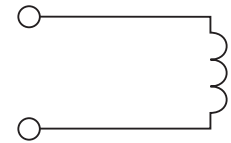
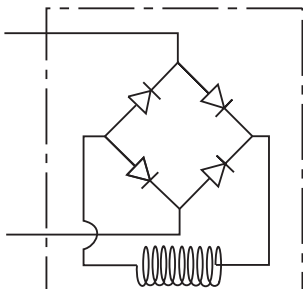

Ordering Information

CA
 Super Coil Wattage Voltage Termination
 5/8" I.D.

Code	Wattage
S	Standard
P	Puissant

Code	Voltage	Watts		Amps		Ohms**	
		S	P	S	P	S	P
012*	12 VDC	18	28	1.50	2.33	8.00	5.14
024*	24 VDC	18	28	0.75	1.17	32.0	20.6
115*	115 VAC	18	28	0.20	0.26	554	417

*Standard Voltages **Resistance ±10% at 68°F

Code	Termination
*D	DIN 43650 (AC or DC, Supplied without DIN Connector)
*HSN	Integral Deutsch with Anti-vibration ring (DC Only)
*HSZN	Integral Deutsch with Anti-vibration ring and Zener Diode (DC Only) *Zener Diode for use with on/off solenoid valves and not recommended for proportional valves.

***UL Listed**

Note: Additional voltages and other terminals may be available. For details please consult factory.
 DIN Female Mating Connector: See page CE3
 Deutsch Mating Connector: # DT06-2S

CV Check Valves

SH Shuttle Valves

LM Load/Motor Controls

FC Flow Controls

PC Pressure Controls

LE Logic Elements

DC Directional Controls

SV Solenoid Valves

PV Proportional Valves

CE Coils & Electronics

BC Bodies & Cavities

TD Technical Data

Terminal Styles and Dimensions

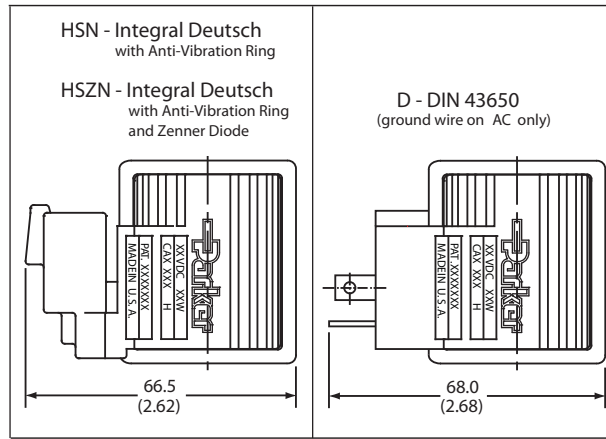
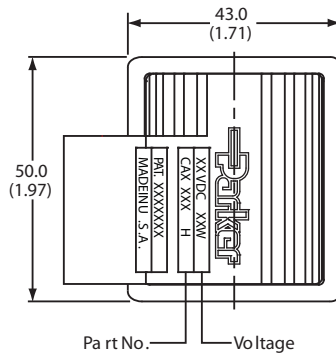
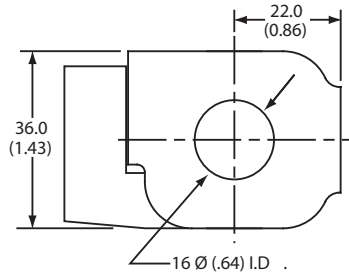

NOTES:

1. The standard A.C. coil includes a molded-in full wave rectifier rated for 800 peak reverse voltage.
2. All P Puissant (high wattage) coils use a red ring as an indication marker on the terminal boss. (No ring on Integral Deutsch connector).



CV
Check Valves
SH
Shuttle Valves
LM
Load/Motor Controls
FC
Flow Controls
PC
Pressure Controls
LE
Logic Elements
DC
Directional Controls
SV
Solenoid Valves
PV
Proportional Valves
CE
Coils & Electronics
BC
Bodies & Cavities
TD
Technical Data

Features

- For utilization on **EPR083R** product only
- Integral Deutsch connector coil exceeds IP69K standards
- Integral Deutsch connector coil thermal shock dunk test rated
- Coil hermetically sealed, requires no O-rings or waterproofing kits
- Coil shell is zinc plated, low carbon steel
- Symmetrical coil can be reversed without affecting performance



Specifications

Nominal Wattage	L 14 Watts
Duty Cycle	Continuous @ 100% voltage
Lead Wire	(12 VDC) 22 gauge 24" long (24 VDC) 22 gauge 24" long
Magnetic Wire Insulation Class	'N' Rated at 200°C (392°F)
Temperature Range	-40°C to +200°C (-40°F to +392°F)
Encapsulating	Glass-Filled Polyethylene Material Terephthalate (PET)
Weight	0.29 kg (0.64 lbs.)

Ordering Information

SW7	L		
1/2" I.D.	Wattage 14W	Termination	Voltage

Code	Wattage
L	Standard, 14W

Code	Termination
H	Integral Deutsch
W	Double Lead

Code	Voltage				
	Volts	Watts (Ref)	Amps (Ref)	Ohms* (Ref)	Lead Wire** Color
D012	12VDC	14.2	1.2	10.1	Red
D024	24VDC	14.5	0.6	39.6	Blue

*Resistance ±5% at 68°F

*Applicable to W Double Lead Termination

Note: Additional voltages and other terminals may be available.
 For details please consult factory.
 Deutsch Mating Connector: # DT06-2S

CV
Check Valves

SH
Shuttle Valves

LM
Load/Motor Controls

FC
Flow Controls

PC
Pressure Controls

LE
Logic Elements

DC
Directional Controls

SV
Solenoid Valves

PV
Proportional Valves

CE
Coils & Electronics

BC
Bodies & Cavities

TD
Technical Data

Terminal Styles and Dimensions

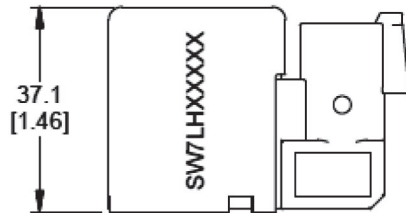
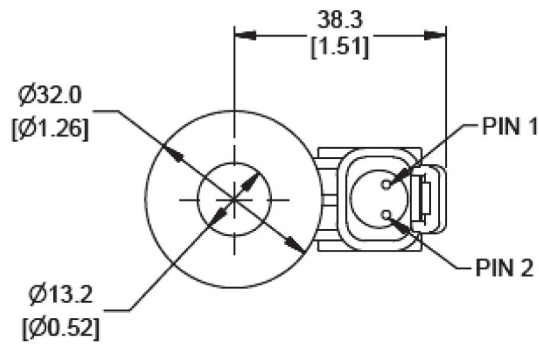

H - Integral Deutsch

W - Double Lead

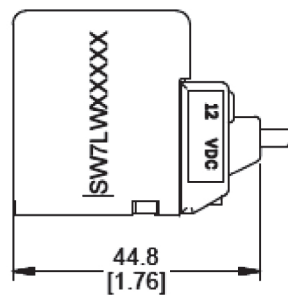
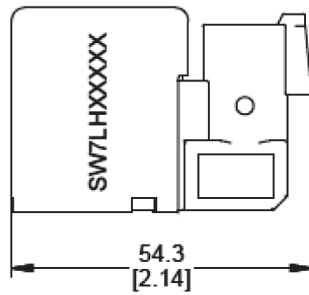

CV
Check Valves

SH
Shuttle Valves

LM
Load/Motor Controls

FC
Flow Controls

PC
Pressure Controls

LE
Logic Elements

DC
Directional Controls

SV
Solenoid Valves

PV
Proportional Valves

CE
Coils & Electronics

BC
Bodies & Cavities

TD
Technical Data

SERIES	DESCRIPTION	BODY NO.	PAGE NO.
Technical Tips.....			BC2-BC3
PARKER STANDARD BODIES AND CAVITIES			
C04-3.....	04 Size, 3 Way.....	B04-3-*	BC4
C08-2.....	08 Size, 2 Way.....	B08-2-*	BC5
C08-3.....	08 Size, 3 Way.....	B08-3-*	BC6
C08-3L.....	08 Size, 3 Way, Long.....	B08-3L-*	BC7
C08-4.....	08 Size, 4 Way.....	B08-4-*	BC8
C10-2.....	10 Size, 2 Way.....	B10-2-*	BC9
C10-3.....	10 Size, 3 Way.....	B10-3-*	BC10
C10-3L.....	10 Size, 3 Way, Long.....	B10-3L-*	BC11
C10-3S.....	10 Size, 3 Way, Short.....	B10-3S-*	BC12
C10-4.....	10 Size, 4 Way.....	B10-4-*	BC13
C12-2.....	12 Size, 2 Way.....	B12-2-*	BC14
C12-3.....	12 Size, 3 Way.....	B12-3-*	BC15
C16-2.....	16 Size, 2 Way.....	B16-2-*	BC16
C16-3.....	16 Size, 3 Way.....	B16-3-*	BC17
C16-3S.....	16 Size, 3 Way, Short.....	B16-3S-*	BC18
C16-4.....	16 Size, 4 Way.....	B16-4-*	BC19
C20-2.....	20 Size, 2 Way.....	B20-2-*	BC20
C20-3S.....	20 Size, 3 Way, Short.....	B20-3S-*	BC21
COUNTERBALANCE CAVITIES AND BODIES			
MHC-010.....	Single and Dual Counterbalance Bodies.....	MHC-010-*	BC22
PILOT PISTON CAVITIES			
10 Size.....	10 Size Cavity for Dual Check and Pilot Piston.....		BC23
SPECIAL BODIES AND CAVITIES			
CAVOW-2.....	2 Port.....	LB10795S.....	BC24
CAVSW-3.....	3 Port.....	LB10815S.....	BC25
CAVT11A.....	3 Port.....	LB10825S.....	BC26
2C.....	2 Port.....	LB10212S.....	BC27
2R.....	2 Port.....	LB10543S.....	BC28
2U.....	2 Port.....	LB10220S.....	BC29
3A.....	3 Port.....	LB10066S.....	BC30
3C.....	3 Port.....	LB10069S.....	BC31
3K.....	3 Port.....	LB10089S.....	BC32
3M.....	3 Port.....	LB10078S.....	BC33
3X.....	3 Port.....	LB10553S.....	BC34
4C.....	4 Port.....	LB10562S.....	BC35
5A.....	5 Port.....	LB10321S.....	BC36
53-1.....	3 Port.....	LB10318S.....	BC37
68-1.....	3 Port.....	LB10253S.....	BC38
100-1.....	5 Port.....	LB10317S.....	BC39

CV

Check Valves

SH

Shuttle Valves

LM

Load/Motor Controls

FC

Flow Controls

PC

Pressure Controls

LE

Logic Elements

DC

Directional Controls

SV

Solenoid Valves

PV

Proportional Valves

CE

Coils & Electronics

BC

Bodies & Cavities

TD

Technical Data



INTRODUCTION

This Technical Tips section is split into two parts; Standard Line Bodies and Cavities. In the standard line bodies section, we highlight the features and options of our standard offering of line bodies. In the cavity section we discuss “common” cavities.

The Technical Tips are provided to help you become more familiar with Parker Hannifin’s line of product and assist you in applying our product.

STANDARD LINE BODIES

Parker offers standard line bodies for each valve and cavity size. Below are some of the features of Parker’s standard line bodies.

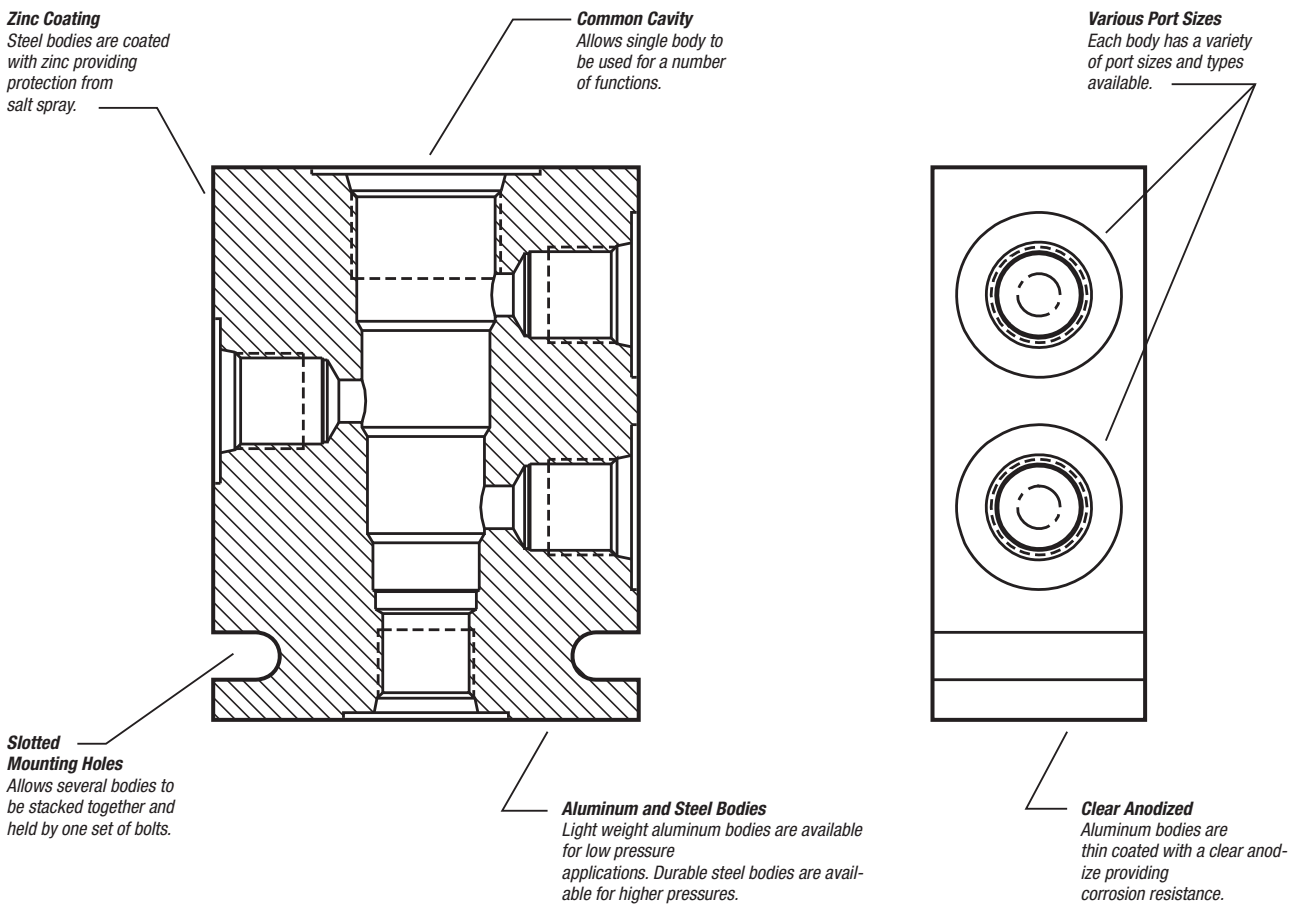

COMMON OPTIONS & FEATURES

Aluminum vs. Steel: Parker offers standard line bodies in both aluminum and steel. Aluminum bodies are most often used for general applications. Parker’s aluminum bodies are coated with a clear anodize to provide a corrosion resistant protection. Aluminum bodies should never be used in applications above 210 bar (3000 psi.) Steel bodies are more durable and

heavier than aluminum bodies. They are ideal for applications with elevated pressures or where rugged construction is desired. Steel bodies are suitable for applications up to 350 bar (5000 psi.) Parker’s steel bodies are coated with zinc providing corrosion resistance. Zinc even provides the steel body many hours of protection from salt spray.

CV	Check Valves
SH	Shuttle Valves
LM	Load/Motor Controls
FC	Flow Controls
PC	Pressure Controls
LE	Logic Elements
DC	Directional Controls
SV	Solenoid Valves
PV	Proportional Valves
CE	Coils & Electronics
BC	Bodies & Cavities
TD	Technical Data

COMMON OPTIONS & FEATURES (Cont.)

Pressure Drop: The pressure drop through a line body is fairly minimal. Each catalog page shows a pressure drop curve. This should be added to the pressure drop through the cartridge when trying to estimate total pressure drop for a function.

Porting: Parker offers a variety of port sizes and types for each line body. While NPT or pipe ports were once very popular and are still offered, we recommend SAE ports for new applications. SAE ports and fittings provide a more secure connection than pipe ports.

“If using an HY15-3502 or an older catalog, note we have re-numbered the ports on our 3-way line bodies” In the past, three way bodies were numbered with the nose being port 1, the middle port labeled (3), and the

top port labeled (2). Over the years, this has caused some confusion, so we have relabeled the ports sequentially from the bottom.

For identification, the current design will be marked with a Parker symbol like the one shown.

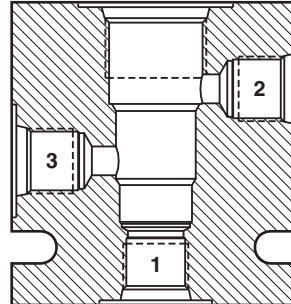

Previous Design

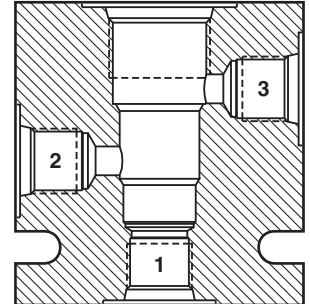

Current Design

CAVITIES

The hole that the cartridge valve is screwed into is called a cavity. Many cartridge producers manufacture valves that fit a “common” cavity. With a “common” cavity, a valve theoretically could be removed from a cavity and replaced by another manufacturer’s product. One should be careful though to check cross drill ports and thread depths when pursuing this activity. While it is true that many manufacturer’s products fit inside another’s cavity, the cross drills sometimes expose an o-ring to pressure, causing the o-ring to be extruded.

Valve / Cavity Compatibility Chart: Through acquisition, Parker Hannifin has accumulated a number of manufacturers with “common” cavities. To accommodate all of our product lines, you will find a chart like the one shown on this page on each catalog page. The purpose of this chart is to help identify if a valve from one acquisition can be replaced by a Parker valve, or another acquisition valve. The valves are designated by the columns of the chart and the cavities by the rows. If you have an existing cavity, you find it on the chart and follow across to see which valves you may put in the cavity. For instance, using the chart below, let’s say you have an existing manifold in which you had manufactured a FPS cavity (maybe you were using a SV2A-10). By finding the row labeled FPS and following across, you find that you could use the FPS product, or a CEC product of the same size in this cavity. A Parker or Waterman valve will not fit in this cavity without modifying the cavity.

		VALVE			
		Parker	Waterman	FPS	CEC
CAVITY	Parker	X	X		
	Waterman	X	X		
	FPS				
	CEC				

CV

Check Valves

SH

Shuttle Valves

LM

Load/Motor Controls

FC

Flow Controls

PC

Pressure Controls

LE

Logic Elements

DC

Directional Controls

SV

Solenoid Valves

PV

Proportional Valves

CE

Coils & Electronics

BC

Bodies & Cavities

TD

Technical Data

Valve/Cavity Compatibility

For additional information see Technical Tips on pages BC2-BC3.

		VALVE			
		Parker	Waterman	FPS	CEC
CAVITY	Parker	X	X		
	Waterman	X	X		
	FPS				
	CEC				

Performance Curve
Pressure Drop vs. Flow

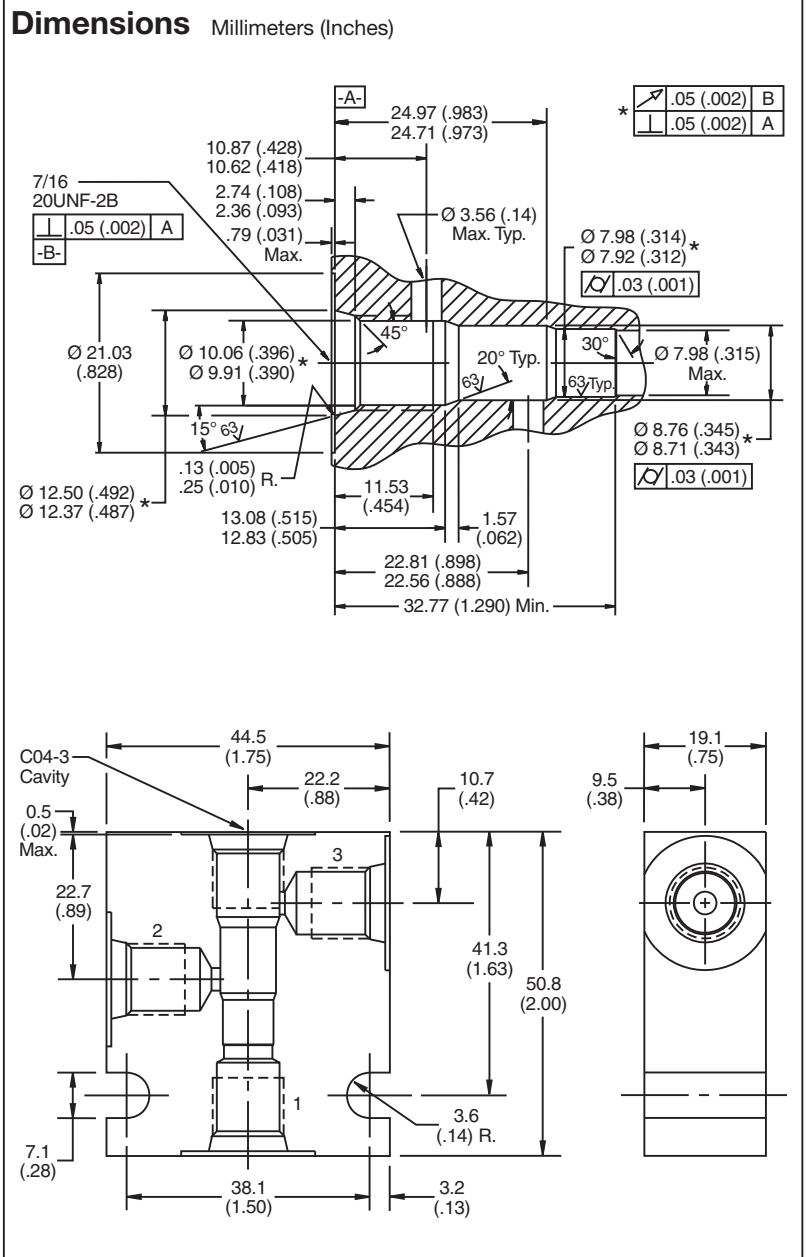
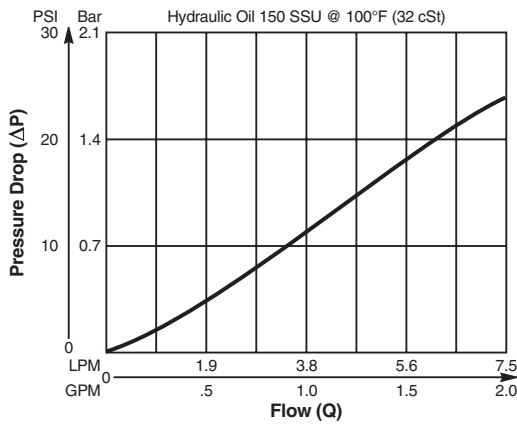

Ordering Information

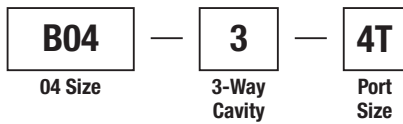

Code	Port Size / Material
4T	SAE-4 Steel

Weight: .10 kg (.23 lbs.)

- CV
- Check Valves
- SH
- Shuttle Valves
- LM
- Load/Motor Controls
- FC
- Flow Controls
- PC
- Pressure Controls
- LE
- Logic Elements
- DC
- Directional Controls
- SV
- Solenoid Valves
- PV
- Proportional Valves
- CE
- Coils & Electronics
- BC
- Bodies & Cavities
- TD
- Technical Data

Valve/Cavity Compatibility

For additional information see Technical Tips on pages BC2-BC3.

		VALVE			
		Parker	Waterman	FPS	CEC
CAVITY	Parker	X	X	X	X
	Waterman	X	X	X	X
	FPS	X	X	X	X
	CEC	X	X	X	X

Performance Curve
Pressure Drop vs. Flow

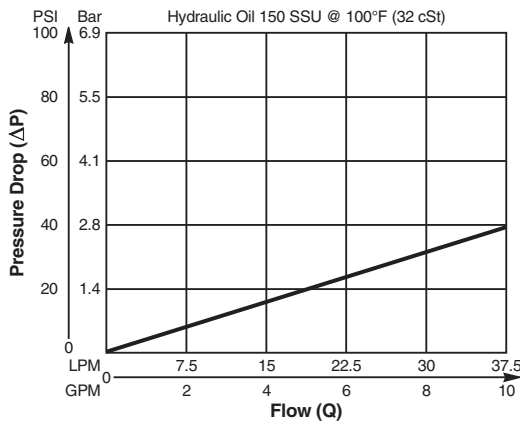

Dimensions Millimeters (Inches)

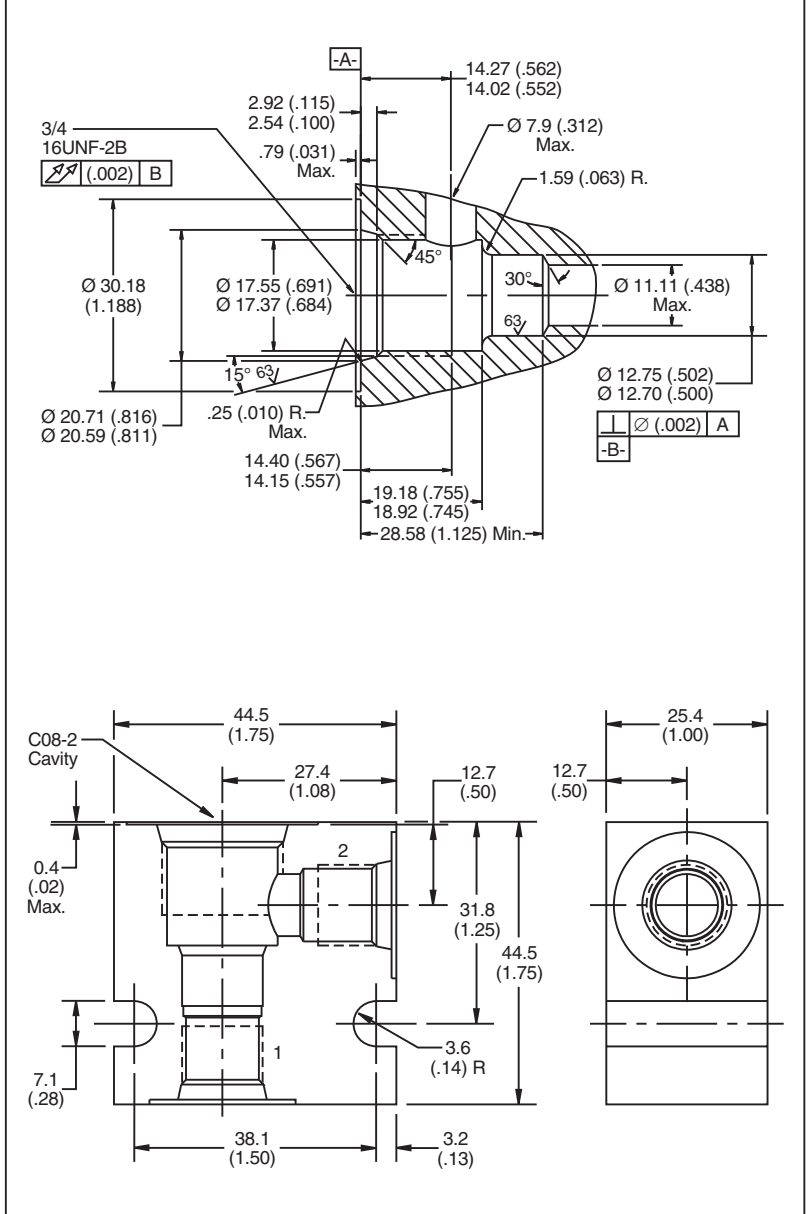

Ordering Information

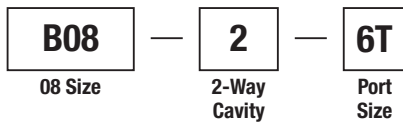

Code	Port Size
6T	SAE - 6/Steel (5000PSI)

Weight: .11 kg (.25 lbs.)

- CV
- Check Valves
- SH
- Shuttle Valves
- LM
- Load/Motor Controls
- FC
- Flow Controls
- PC
- Pressure Controls
- LE
- Logic Elements
- DC
- Directional Controls
- SV
- Solenoid Valves
- PV
- Proportional Valves
- CE
- Coils & Electronics
- BC
- Bodies & Cavities
- TD
- Technical Data

Valve/Cavity Compatibility

For additional information see Technical Tips on pages BC2-BC3.

		VALVE			
		Parker	Waterman	FPS	CEC
CAVITY	Parker	X	X		
	Waterman	X	X		
	FPS			X	X
	CEC			X	X

Performance Curve
Pressure Drop vs. Flow

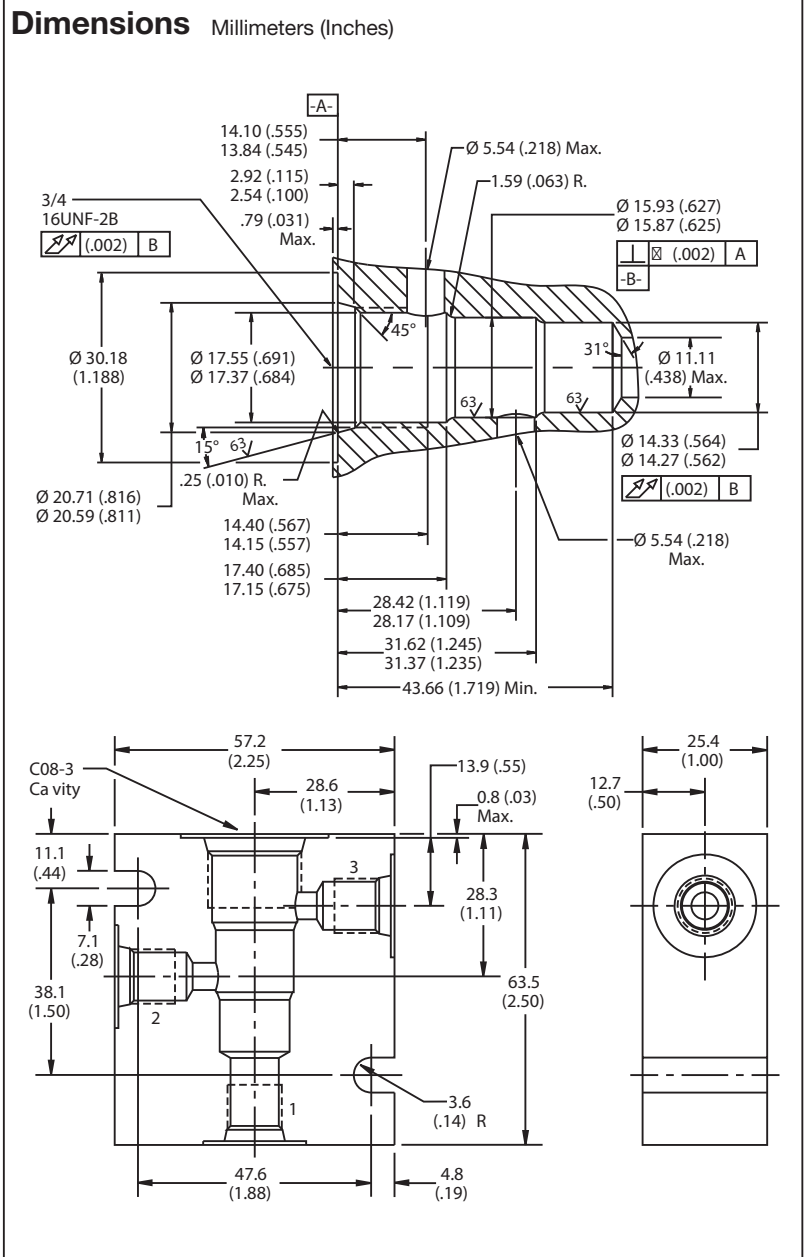
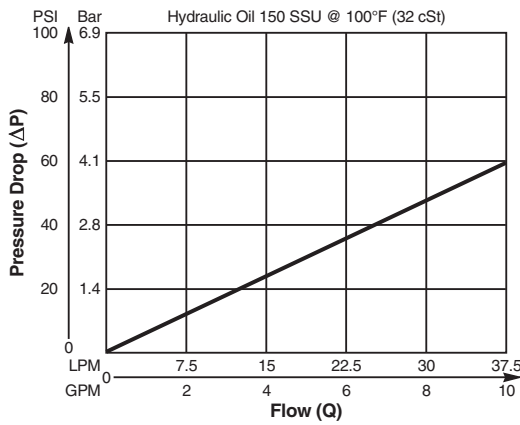

Ordering Information

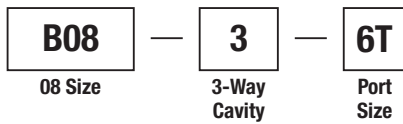

Code	Port Size
6T	SAE - 6/Steel (5000PSI)

Weight: .27 kg (.60 lbs.)

- CV
- Check Valves
- SH
- Shuttle Valves
- LM
- Load/Motor Controls
- FC
- Flow Controls
- PC
- Pressure Controls
- LE
- Logic Elements
- DC
- Directional Controls
- SV
- Solenoid Valves
- PV
- Proportional Valves
- CE
- Coils & Electronics
- BC
- Bodies & Cavities
- TD
- Technical Data

Valve/Cavity Compatibility

For additional information see Technical Tips on pages BC2-BC3.

		VALVE			
		Parker	Waterman	FPS	CEC
CAVITY	Parker	X			
	Waterman				
	FPS				
	CEC				

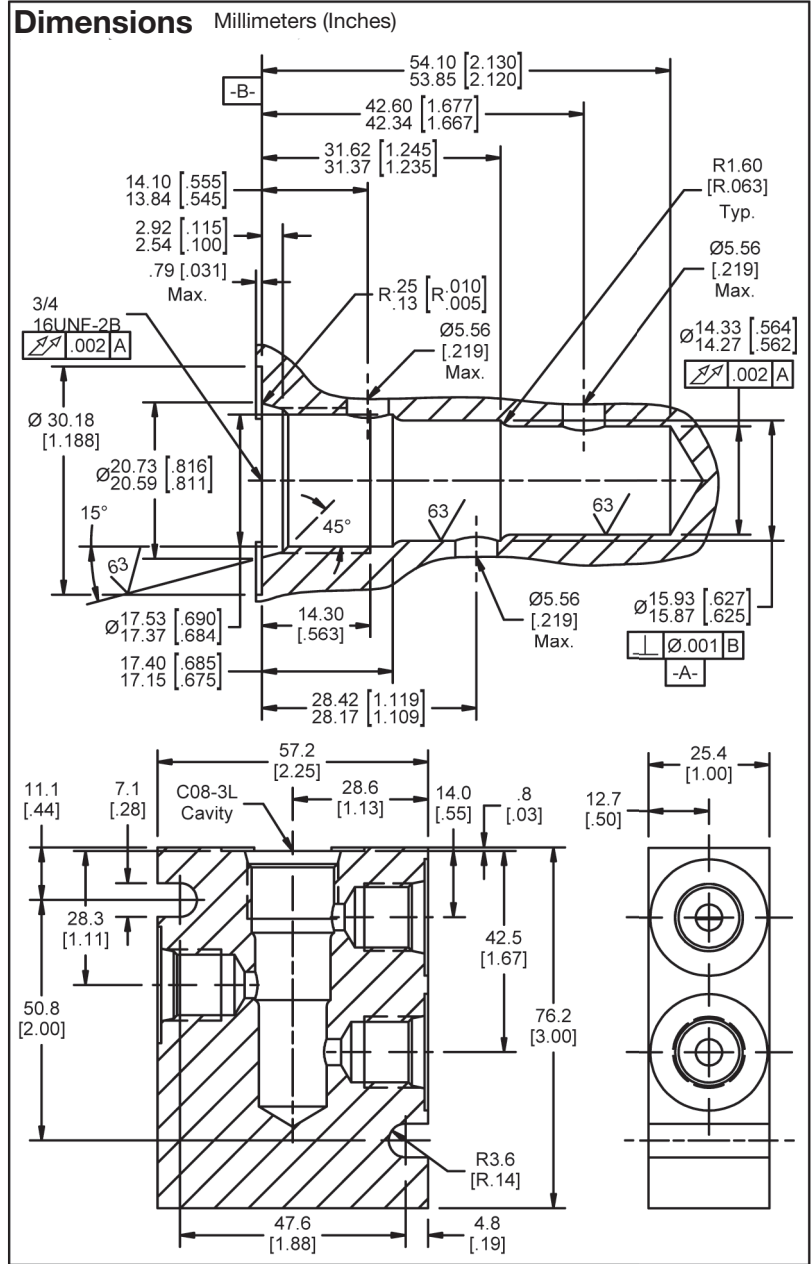

Ordering Information

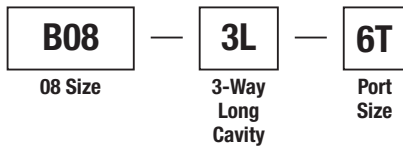

Code	Port Size
6T	SAE - 6/Steel (5000PSI)

Weight: .68 kg (1.5 lbs.)

- CV
- Check Valves
- SH
- Shuttle Valves
- LM
- Load/Motor Controls
- FC
- Flow Controls
- PC
- Pressure Controls
- LE
- Logic Elements
- DC
- Directional Controls
- SV
- Solenoid Valves
- PV
- Proportional Valves
- CE
- Coils & Electronics
- BC
- Bodies & Cavities
- TD
- Technical Data

Valve/Cavity Compatibility

For additional information see Technical Tips on pages BC2-BC3.

		VALVE			
		Parker	Waterman	FPS	CEC
CAVITY	Parker	X	X		
	Waterman	X	X		
	FPS			X	
	CEC				

Performance Curve
Pressure Drop vs. Flow

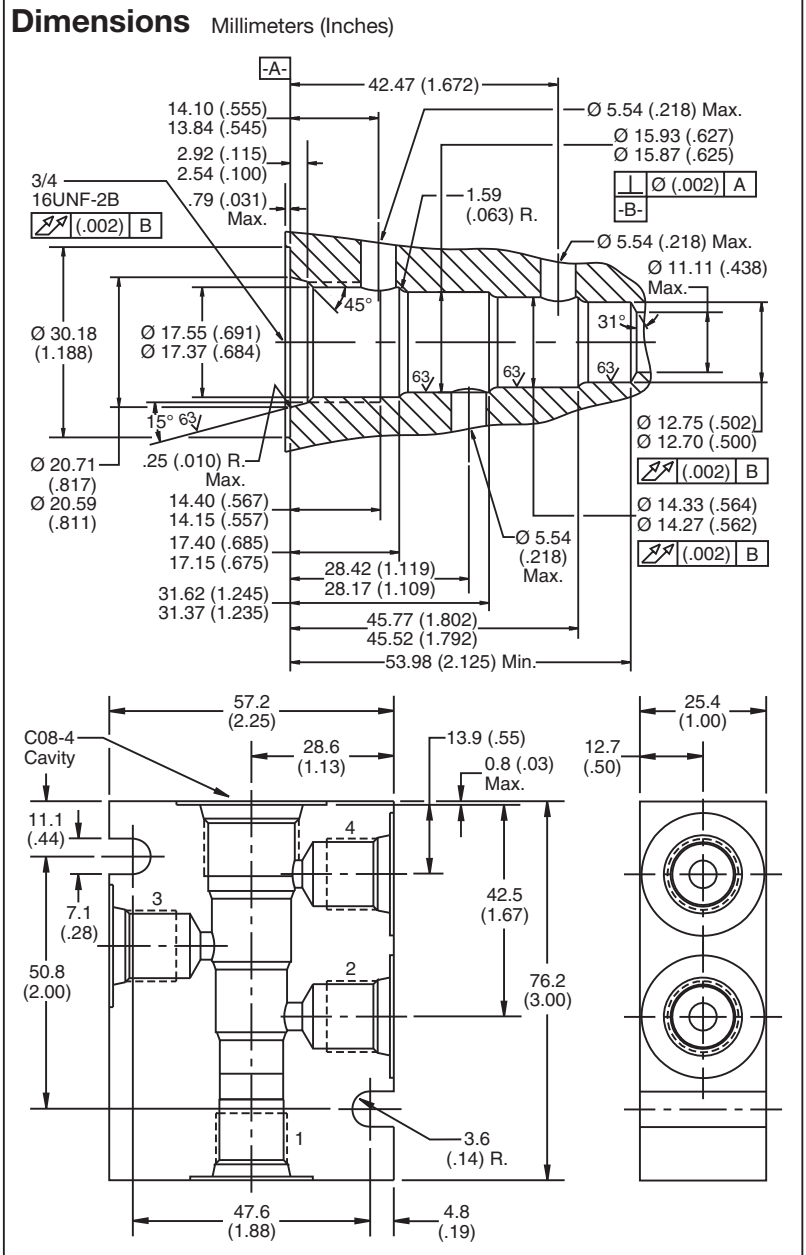
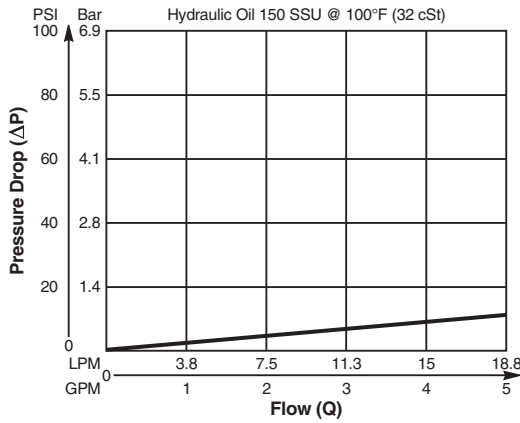

Ordering Information

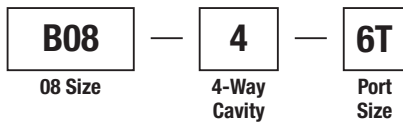

Code	Port Size
6T	SAE - 6/Steel (5000PSI)

Weight: .45 kg (1.0 lbs.)

- CV
- Check Valves
- SH
- Shuttle Valves
- LM
- Load/Motor Controls
- FC
- Flow Controls
- PC
- Pressure Controls
- LE
- Logic Elements
- DC
- Directional Controls
- SV
- Solenoid Valves
- PV
- Proportional Valves
- CE
- Coils & Electronics
- BC
- Bodies & Cavities
- TD
- Technical Data

Valve/Cavity Compatibility

For additional information see Technical Tips on pages BC2-BC3.

		VALVE			
		Parker	Waterman	FPS	CEC
CAVITY	Parker	X	X		
	Waterman	X	X		
	FPS			X	X
	CEC			X	X

Performance Curve
Pressure Drop vs. Flow

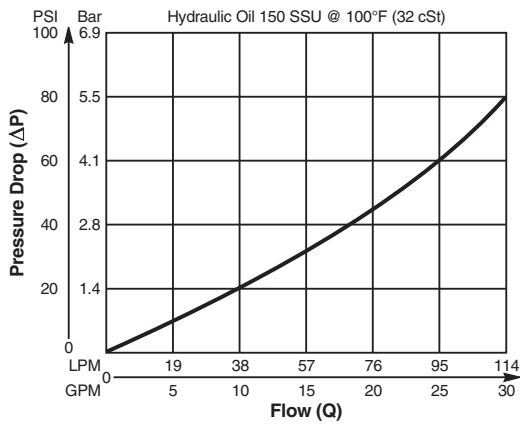

Dimensions Millimeters (Inches)

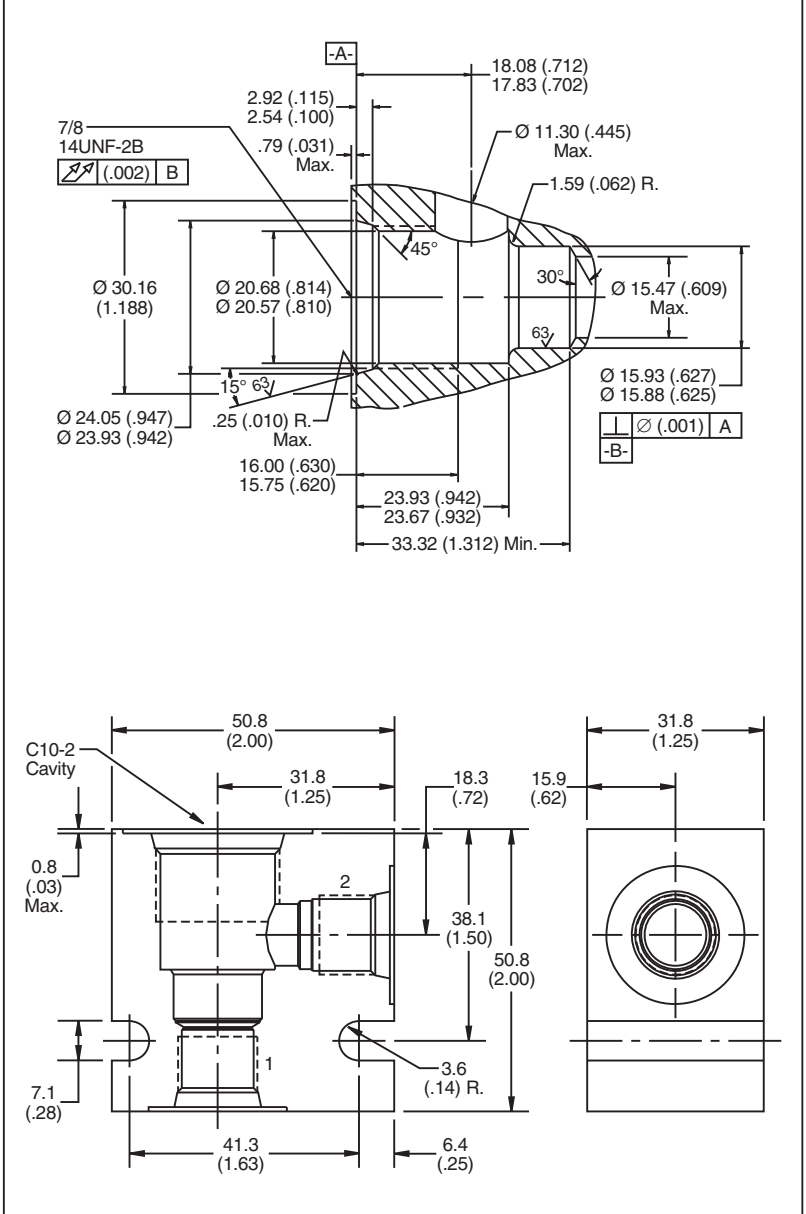

Ordering Information

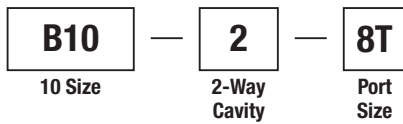

Code	Port Size
8T	SAE - 8/Steel (5000PSI)

Weight: .45 kg (1.0 lbs.)

- CV
- Check Valves
- SH
- Shuttle Valves
- LM
- Load/Motor Controls
- FC
- Flow Controls
- PC
- Pressure Controls
- LE
- Logic Elements
- DC
- Directional Controls
- SV
- Solenoid Valves
- PV
- Proportional Valves
- CE
- Coils & Electronics
- BC
- Bodies & Cavities
- TD
- Technical Data

Valve/Cavity Compatibility

For additional information see Technical Tips on pages BC2-BC3.

		VALVE			
		Parker	Waterman	FPS	CEC
CAVITY	Parker	X	X	X	X
	Waterman	X	X	X	X
	FPS	X	X	X	X
	CEC	X	X	X	X

Performance Curve
Pressure Drop vs. Flow

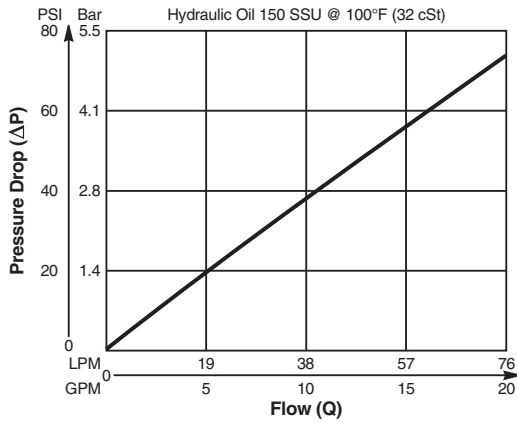

Dimensions Millimeters (Inches)

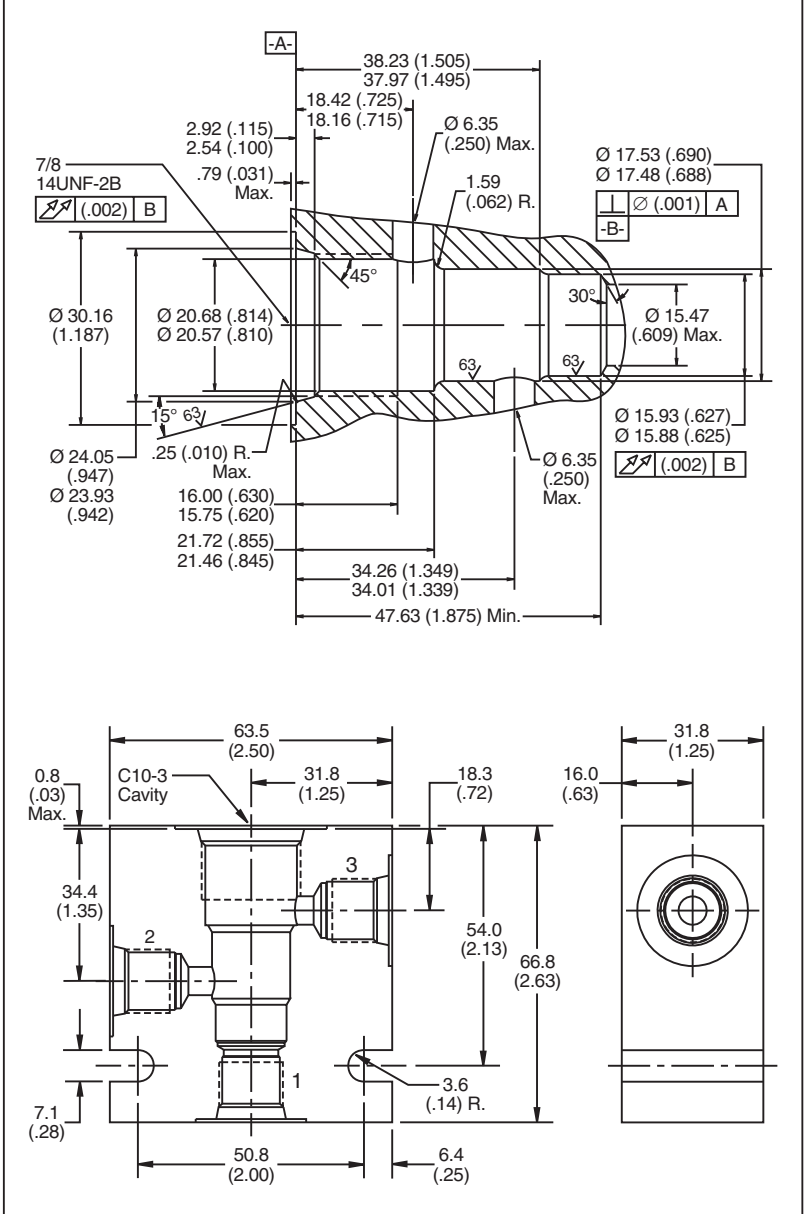

Ordering Information

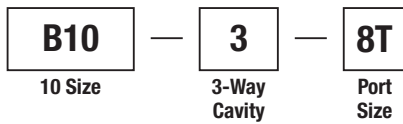

Code	Port Size
8T	SAE - 8/Steel (5000PSI)

Weight: .77 kg (1.7 lbs.)

- CV
- Check Valves
- SH
- Shuttle Valves
- LM
- Load/Motor Controls
- FC
- Flow Controls
- PC
- Pressure Controls
- LE
- Logic Elements
- DC
- Directional Controls
- SV
- Solenoid Valves
- PV
- Proportional Valves
- CE
- Coils & Electronics
- BC
- Bodies & Cavities
- TD
- Technical Data

Valve/Cavity Compatibility

For additional information see Technical Tips on pages BC2-BC3.

		VALVE			
		Parker	Waterman	FPS	CEC
CAVITY	Parker				
	Waterman				
	FPS			X	X
	CEC			X	X

Performance Curve
Pressure Drop vs. Flow

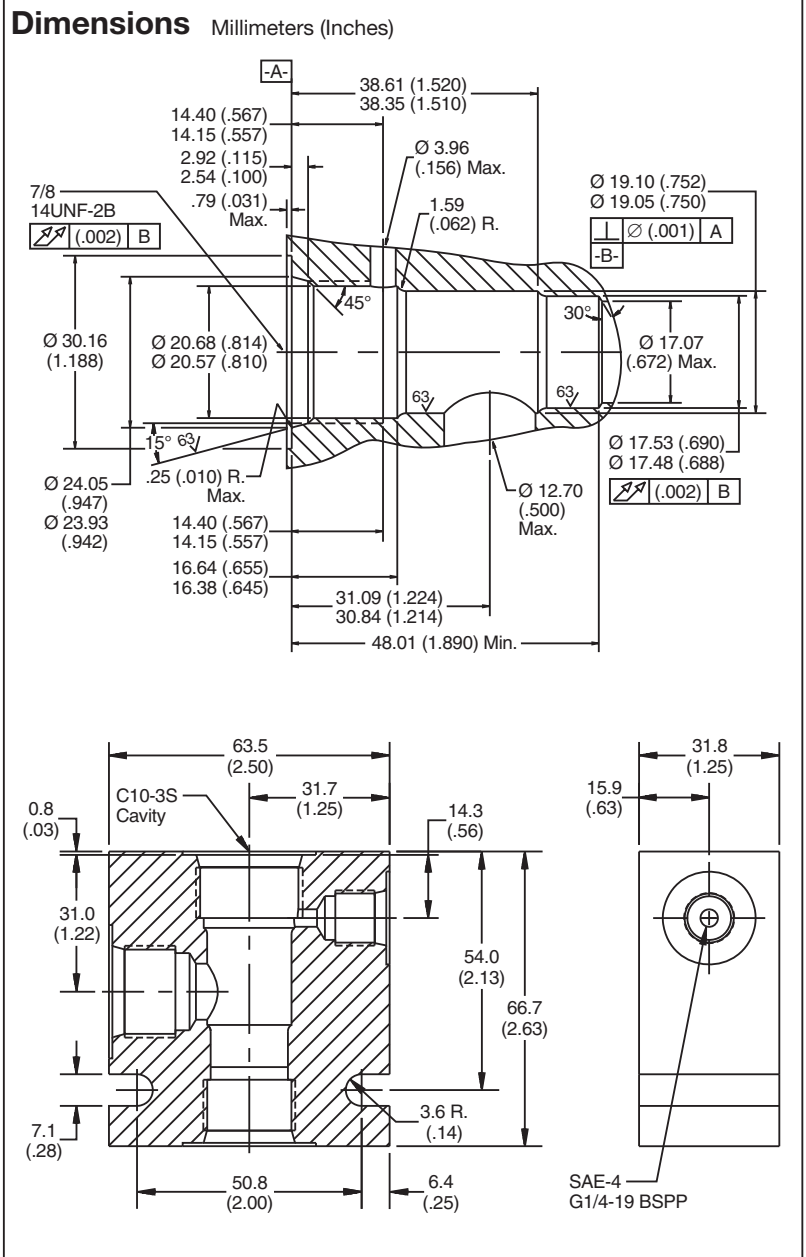
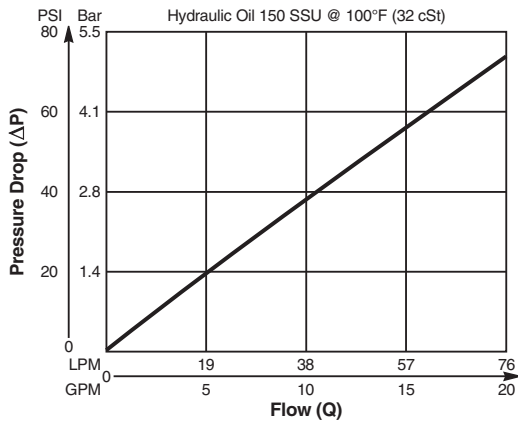

Ordering Information

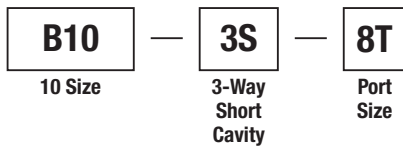

Code	Port Size
8T	SAE - 8/Steel (5000PSI)

Weight: .77 kg (1.7 lbs.)

***Please be advised that this is a non-core line body.**
 Additional lead-time and/or pricing requirements may exist when ordering.

- CV
- Check Valves
- SH
- Shuttle Valves
- LM
- Load/Motor Controls
- FC
- Flow Controls
- PC
- Pressure Controls
- LE
- Logic Elements
- DC
- Directional Controls
- SV
- Solenoid Valves
- PV
- Proportional Valves
- CE
- Coils & Electronics
- BC
- Bodies & Cavities
- TD
- Technical Data

Valve/Cavity Compatibility

For additional information see Technical Tips on pages BC2-BC3.

		VALVE			
		Parker	Waterman	FPS	CEC
CAVITY	Parker	X	X		
	Waterman	X	X		
	FPS				
	CEC				X

Performance Curve
Pressure Drop vs. Flow

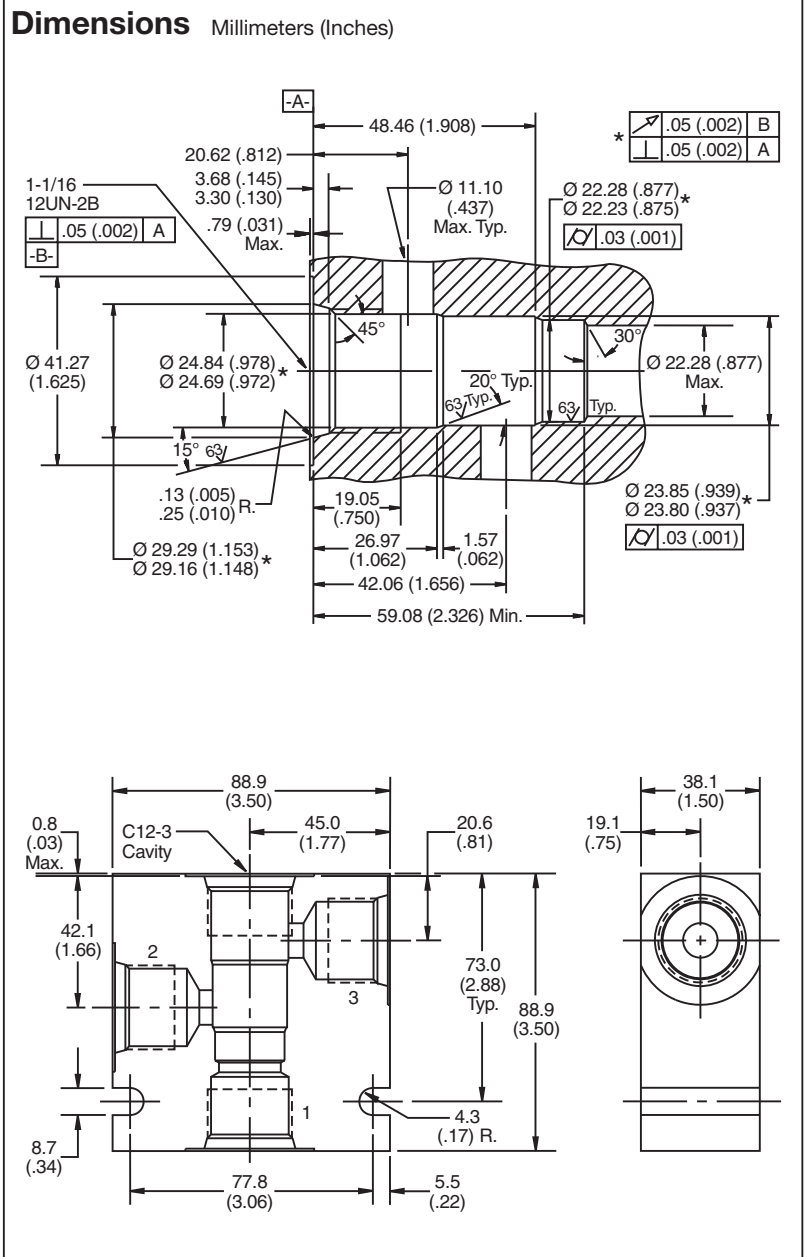
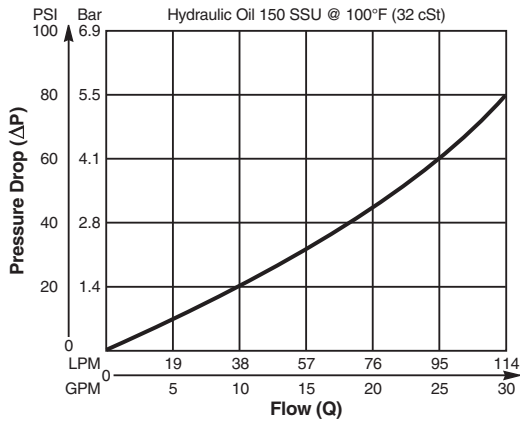

Ordering Information

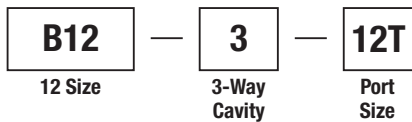

Code	Port Size
12T	SAE - 12/Steel (5000PSI)

Weight: 2.0 kg (4.5 lbs.)

- CV
- Check Valves
- SH
- Shuttle Valves
- LM
- Load/Motor Controls
- FC
- Flow Controls
- PC
- Pressure Controls
- LE
- Logic Elements
- DC
- Directional Controls
- SV
- Solenoid Valves
- PV
- Proportional Valves
- CE
- Coils & Electronics
- BC
- Bodies & Cavities
- TD
- Technical Data

Valve/Cavity Compatibility

For additional information see Technical Tips on pages BC2-BC3.

		VALVE			
		Parker	Waterman	FPS	CEC
CAVITY	Parker	X	X		
	Waterman	X	X		
	FPS			X	X
	CEC			X	X

Performance Curve
Pressure Drop vs. Flow

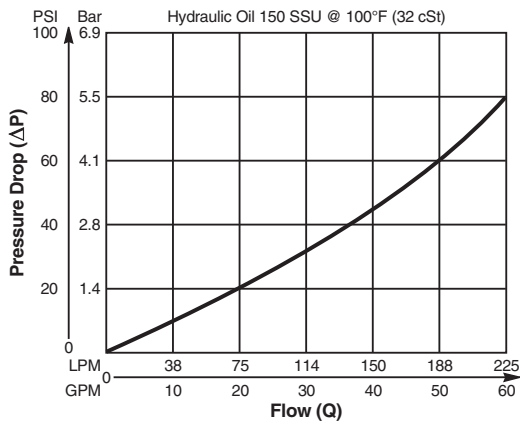

Dimensions Millimeters (Inches)

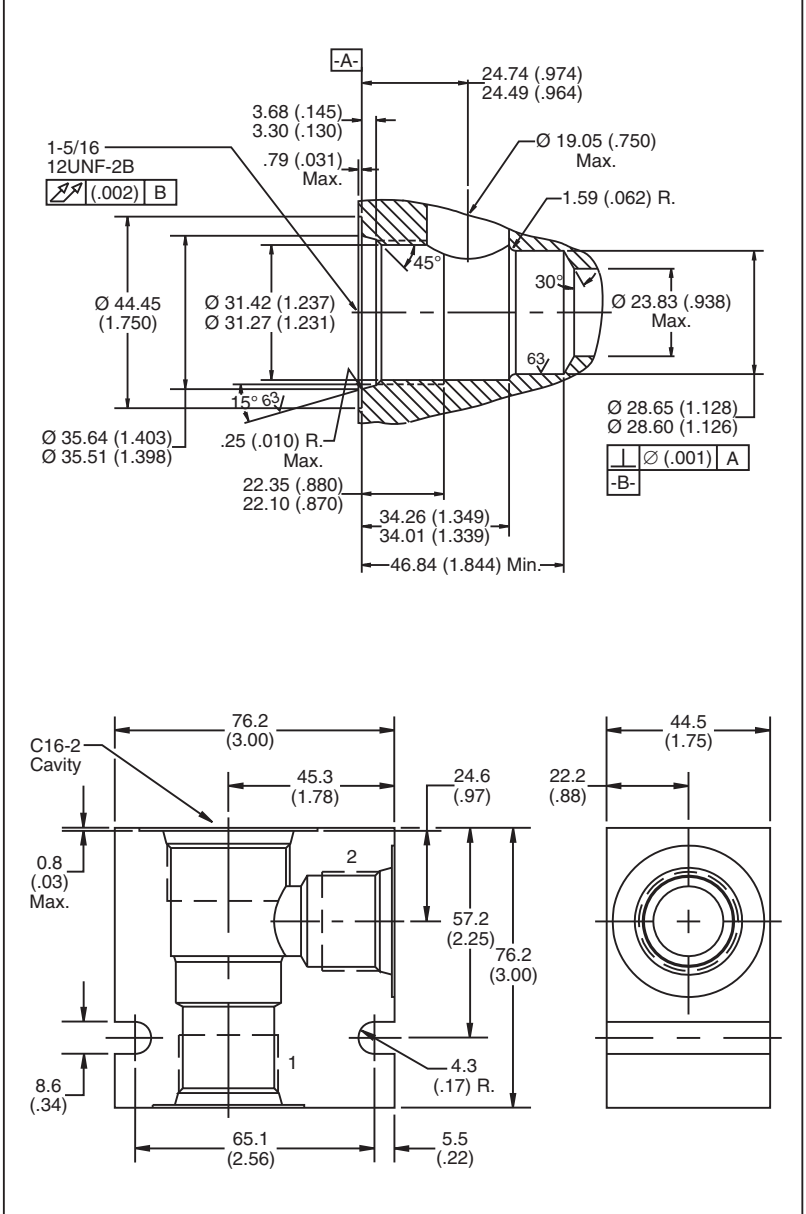

Ordering Information

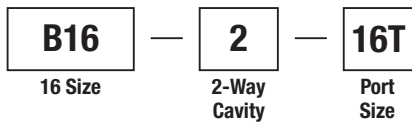

Code	Port Size
16T	SAE - 16/Steel (5000PSI)

Weight: 1.5 kg (3.4 lbs.)

- CV
- Check Valves
- SH
- Shuttle Valves
- LM
- Load/Motor Controls
- FC
- Flow Controls
- PC
- Pressure Controls
- LE
- Logic Elements
- DC
- Directional Controls
- SV
- Solenoid Valves
- PV
- Proportional Valves
- CE
- Coils & Electronics
- BC
- Bodies & Cavities
- TD
- Technical Data

Valve/Cavity Compatibility

For additional information see Technical Tips on pages BC2-BC3.

		VALVE			
		Parker	Waterman	FPS	CEC
CAVITY	Parker	X	X		
	Waterman	X	X		
	FPS			X	X
	CEC			X	X

Performance Curve
Pressure Drop vs. Flow

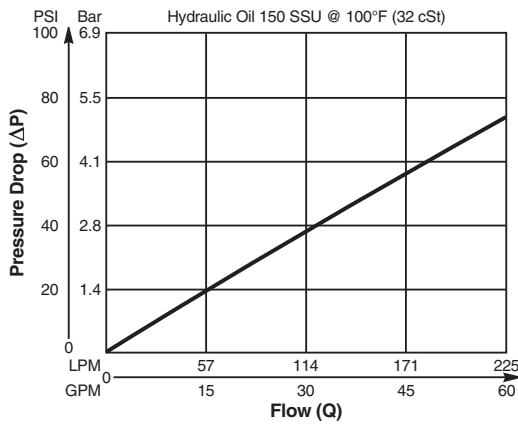

Dimensions Millimeters (Inches)

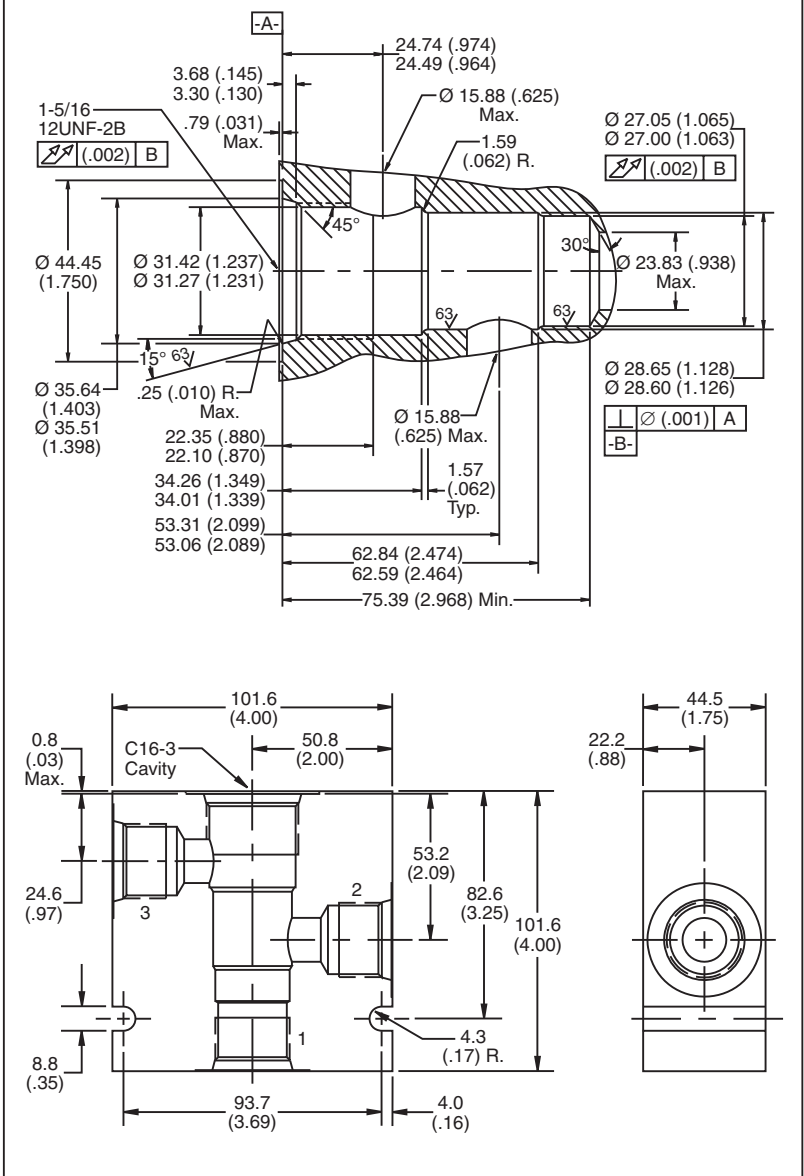

Ordering Information

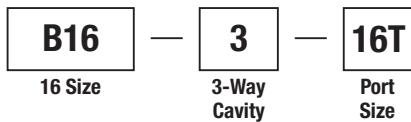

Code	Port Size
16T	SAE - 16/Steel (5000PSI)

Weight: 3.0 kg (6.5 lbs.)

- CV
- Check Valves
- SH
- Shuttle Valves
- LM
- Load/Motor Controls
- FC
- Flow Controls
- PC
- Pressure Controls
- LE
- Logic Elements
- DC
- Directional Controls
- SV
- Solenoid Valves
- PV
- Proportional Valves
- CE
- Coils & Electronics
- BC
- Bodies & Cavities
- TD
- Technical Data

Valve/Cavity Compatibility

For additional information see Technical Tips on pages BC2-BC3.

		VALVE			
		Parker	Waterman	FPS	CEC
CAVITY	Parker	X	X	X	X
	Waterman	X	X	X	X
	FPS	X	X	X	X
	CEC	X	X	X	X

Performance Curve
Pressure Drop vs. Flow

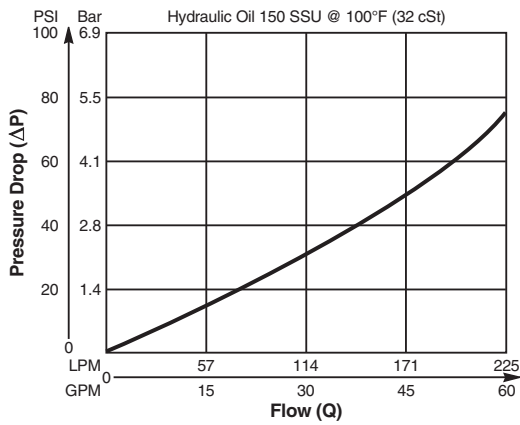

Dimensions Millimeters (Inches)

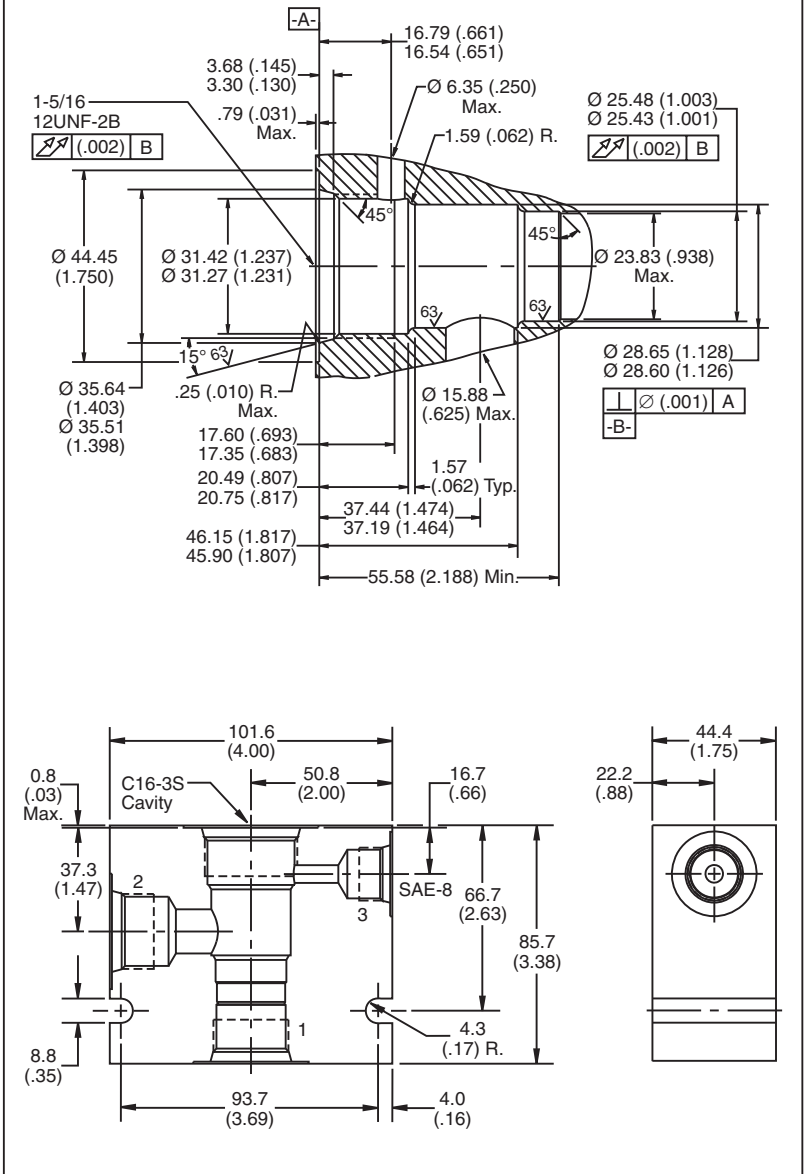

Ordering Information

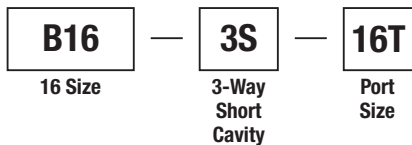

Code	Port Size
16T	SAE - 16/Steel (5000PSI)

Weight: 2.4 kg (5.4 lbs.)

- CV
- Check Valves
- SH
- Shuttle Valves
- LM
- Load/Motor Controls
- FC
- Flow Controls
- PC
- Pressure Controls
- LE
- Logic Elements
- DC
- Directional Controls
- SV
- Solenoid Valves
- PV
- Proportional Valves
- CE
- Coils & Electronics
- BC
- Bodies & Cavities
- TD
- Technical Data

Valve/Cavity Compatibility

For additional information see Technical Tips on pages BC2-BC3.

		VALVE			
		Parker	Waterman	FPS	CEC
CAVITY	Parker	X	X		
	Waterman	X	X		
	FPS			X	X
	CEC			X	X

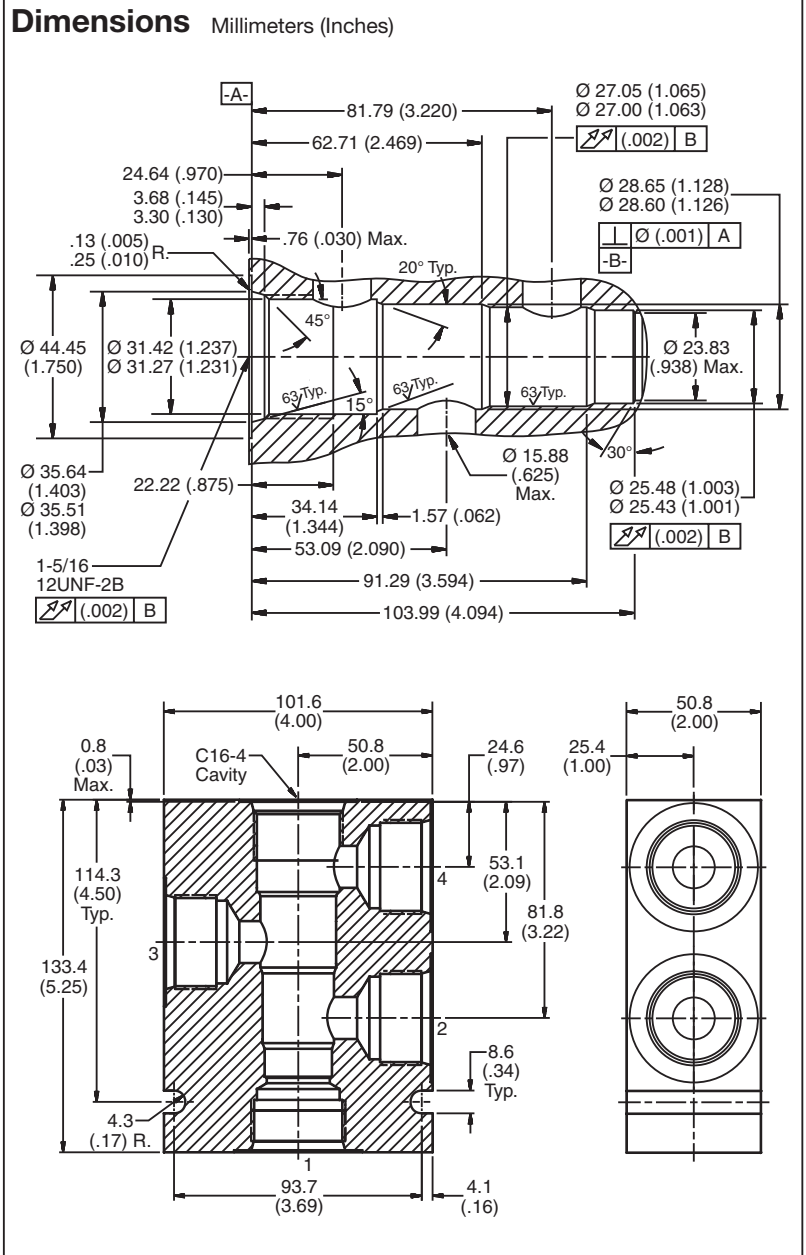

Ordering Information

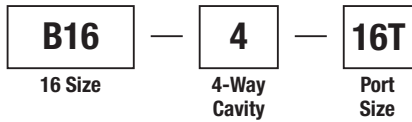

Code	Port Size
16T	SAE - 16/Steel (5000PSI)

Weight: 3.75 kg (8.125 lbs.)

- CV
- Check Valves
- SH
- Shuttle Valves
- LM
- Load/Motor Controls
- FC
- Flow Controls
- PC
- Pressure Controls
- LE
- Logic Elements
- DC
- Directional Controls
- SV
- Solenoid Valves
- PV
- Proportional Valves
- CE
- Coils & Electronics
- BC
- Bodies & Cavities
- TD
- Technical Data

Valve/Cavity Compatibility

For additional information see Technical Tips on pages BC2-BC3.

		VALVE			
		Parker	Waterman	FPS	CEC
CAVITY	Parker				
	Waterman				
	FPS				
	CEC				X

Performance Curve
Pressure Drop vs. Flow

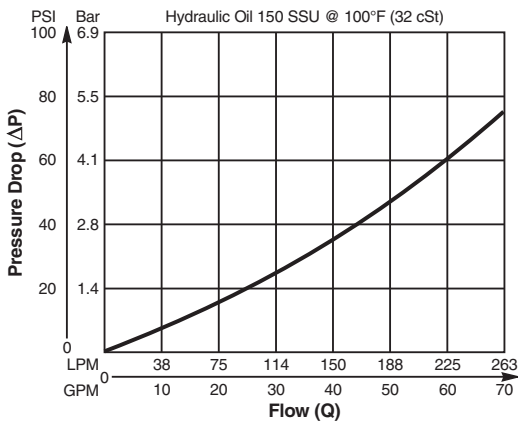

Dimensions Millimeters (Inches)

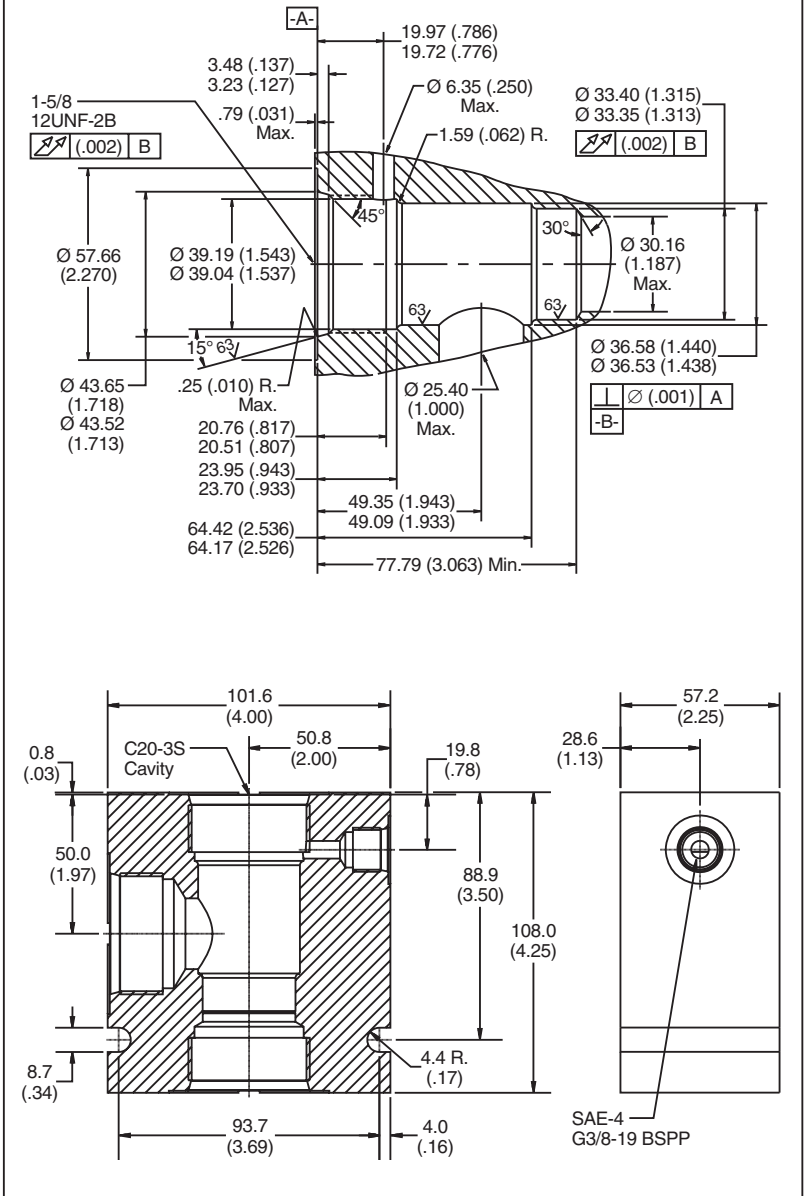

Ordering Information

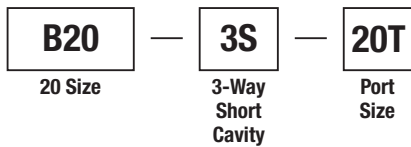

Code	Port Size
20T	SAE - 20/Steel (5000PSI)

Weight: 10.8 kg (22.2 lbs.)

***Please be advised that this is a non-core line body.**
 Additional lead-time and/or pricing requirements may exist when ordering.



- CV
- Check Valves
- SH
- Shuttle Valves
- LM
- Load/Motor Controls
- FC
- Flow Controls
- PC
- Pressure Controls
- LE
- Logic Elements
- DC
- Directional Controls
- SV
- Solenoid Valves
- PV
- Proportional Valves
- CE
- Coils & Electronics
- BC
- Bodies & Cavities
- TD
- Technical Data

Valve/Cavity Compatibility

For additional information see Technical Tips on pages BC2-BC3.

		VALVE	
		MHC-010	2-N-4*-10
CAVITY	MHC-010	X	X
	2-N-4*-10	X	X

Dimensions Millimeters (Inches)

CDD-1010

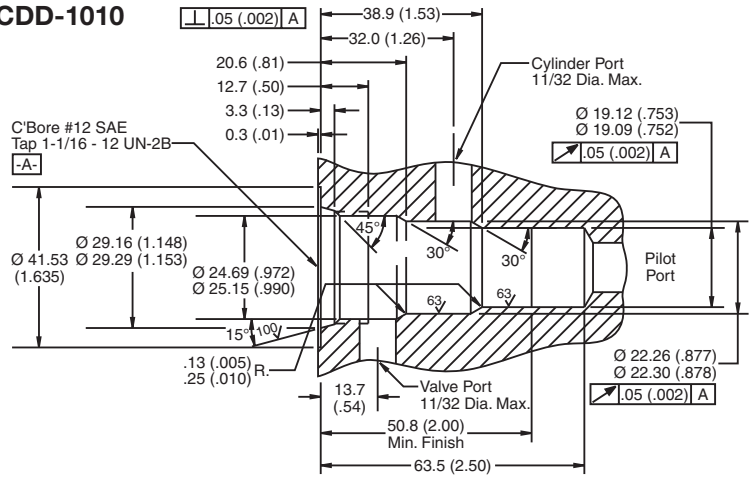

Single Body

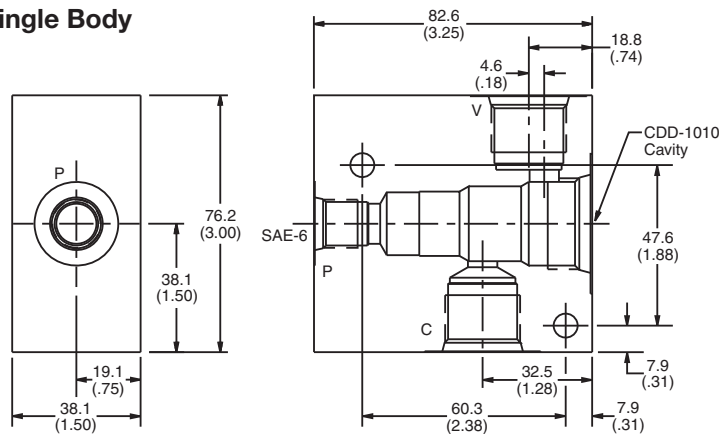

Ordering Information

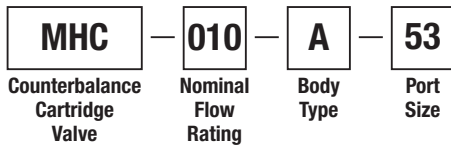

Code	Body Type	Code	Port Size
A	Single	53	SAE-10 through port

Weight: Single 1.1 kg (2.25 lbs.)

***Please be advised that this is a non-core line body. Additional lead-time and/or pricing requirements may exist when ordering.**

CV
Check Valves
SH
Shuttle Valves
LM
Load/Motor Controls
FC
Flow Controls
PC
Pressure Controls
LE
Logic Elements
DC
Directional Controls
SV
Solenoid Valves
PV
Proportional Valves
CE
Coils & Electronics
BC
Bodies & Cavities
TD
Technical Data

Dimensions Millimeters (Inches)

**10 Size Cavity for Dual
 Check and Pilot Piston**

*For Check Valves Use 2
 CVH103P***

*For Pilot Piston Use
 717917 No Seal*

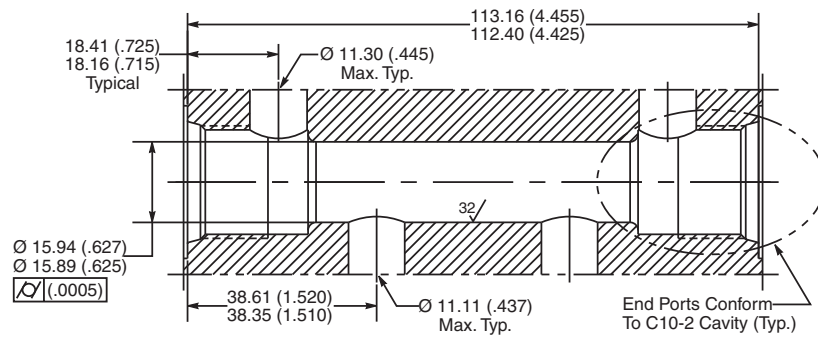

CV
 Check Valves

SH
 Shuttle Valves

LM
 Load/Motor Controls

FC
 Flow Controls

PC
 Pressure Controls

LE
 Logic Elements

DC
 Directional Controls

SV
 Solenoid Valves

PV
 Proportional Valves

CE
 Coils & Electronics

BC
 Bodies & Cavities

TD
 Technical Data

For additional information see Technical Tips on pages BC2-BC3.

Dimensions

Millimeters (Inches)

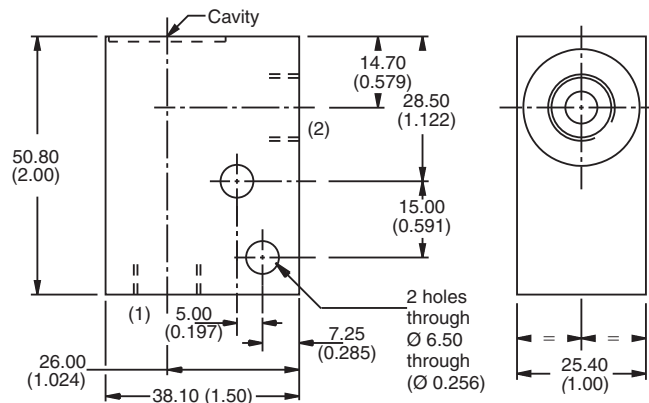
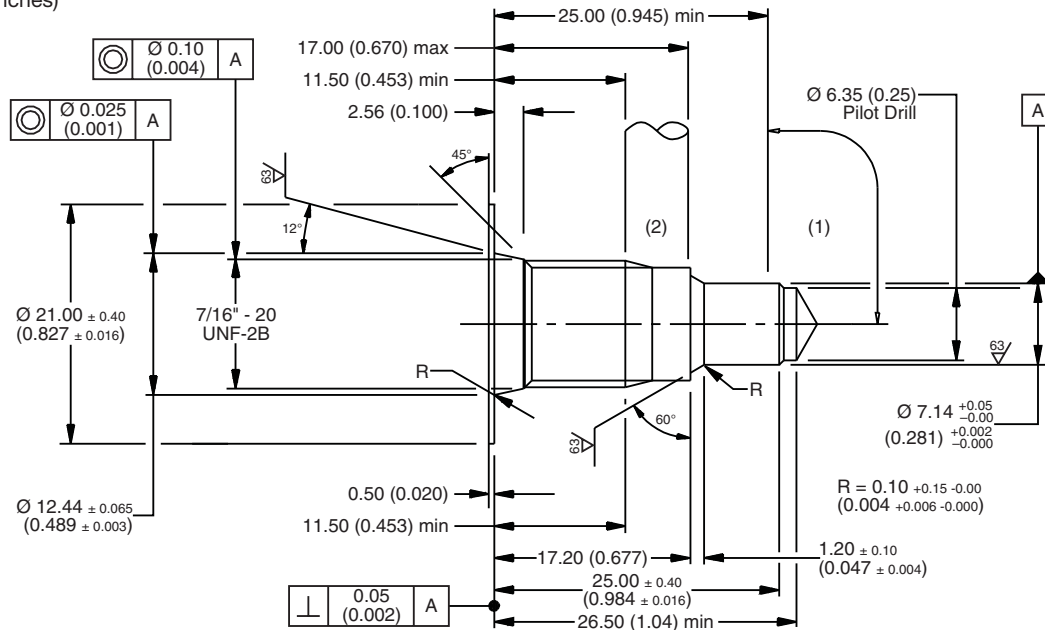

Ordering Information

LB10	795	S
Line Body	Port Size	Body Material

Code	Port Size
795	1/4 SAE

Code	Body Material
S	Steel

***Please be advised that this is a non-core line body.
 Additional lead-time and/or pricing requirements may exist when ordering.**

For additional information see Technical Tips on pages BC2-BC3.

Dimensions

Millimeters (Inches)

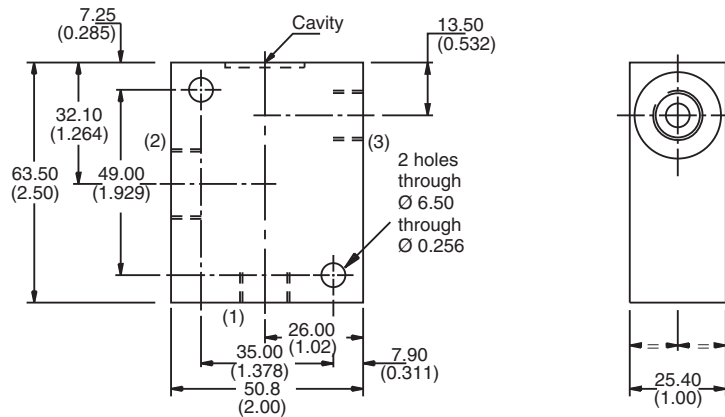
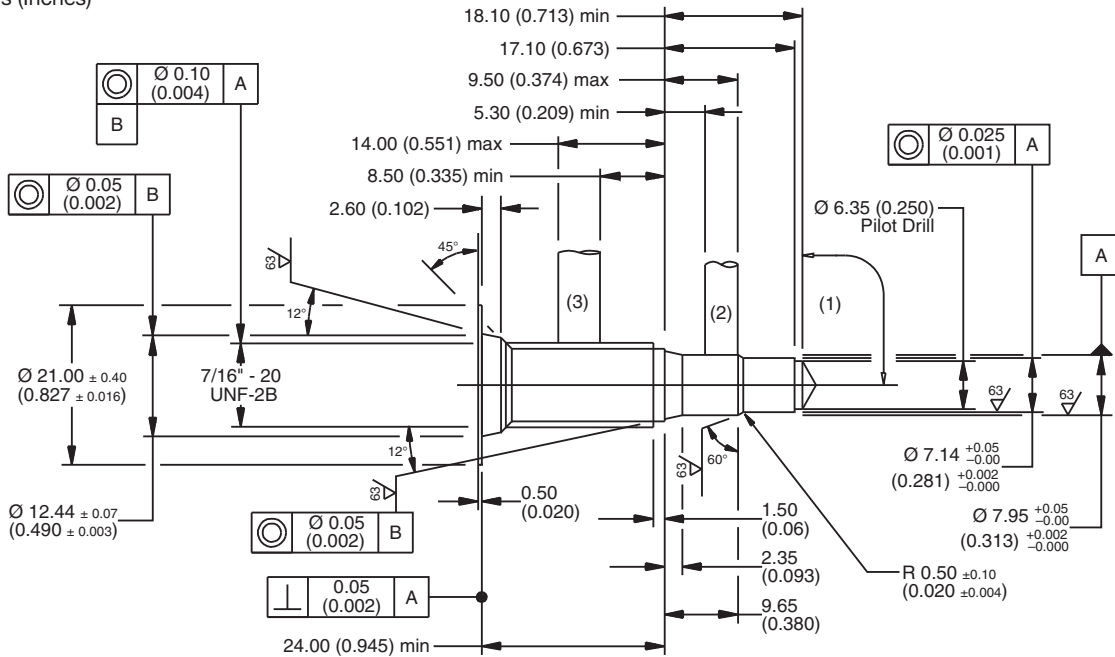

Ordering Information

LB10	815	S
Line Body	Port Size	Body Material

Code	Port Size
815	1/4 SAE

Code	Body Material
S	Steel

***Please be advised that this is a non-core line body.
 Additional lead-time and/or pricing requirements may exist when ordering.**

For additional information see Technical Tips on pages BC2-BC3.

Dimensions
 Millimeters (Inches)

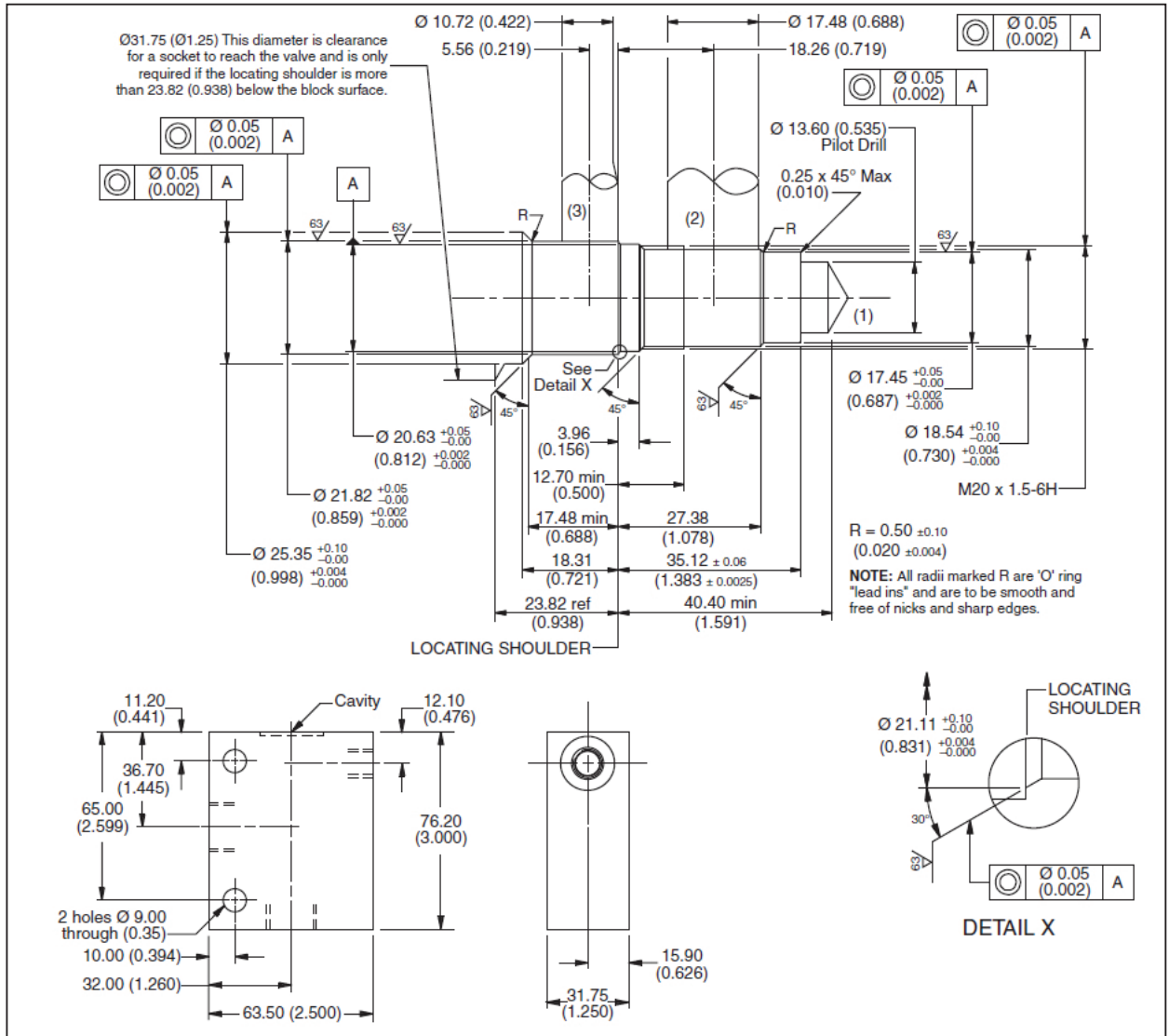

Ordering Information

LB10	825	S
Line Body	Port Size	Body Material

Code	Port Size
825	1/4 SAE

Code	Body Material
S	Steel

***Please be advised that this is a non-core line body.**
 Additional lead-time and/or pricing requirements may exist when ordering.

- CV
- Check Valves
- SH
- Shuttle Valves
- LM
- Load/Motor Controls
- FC
- Flow Controls
- PC
- Pressure Controls
- LE
- Logic Elements
- DC
- Directional Controls
- SV
- Solenoid Valves
- PV
- Proportional Valves
- CE
- Coils & Electronics
- BC
- Bodies & Cavities
- TD
- Technical Data

For additional information see Technical Tips on pages BC2-BC3.

Dimensions
 Millimeters (Inches)

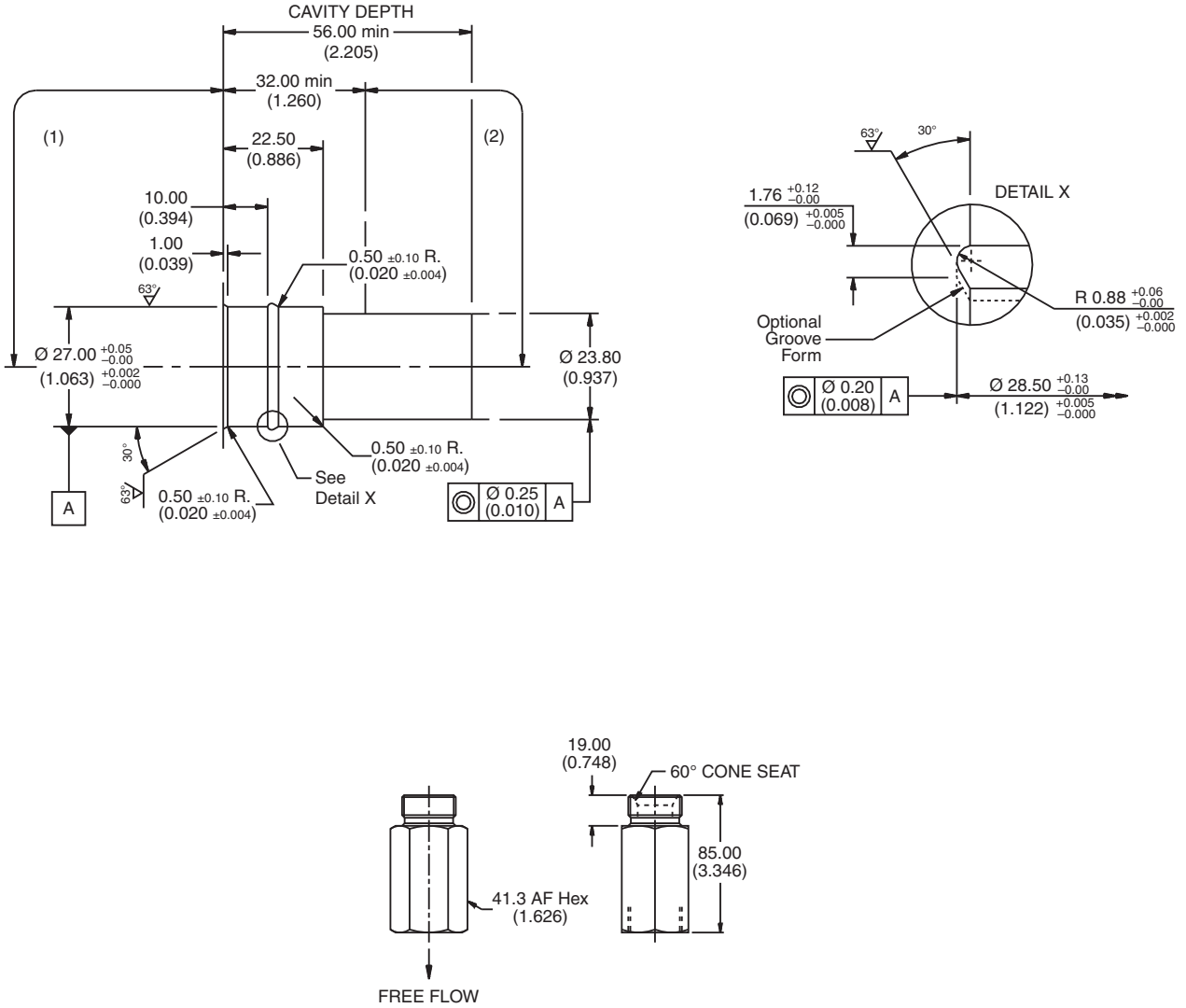

Ordering Information

LB10	212	S
Line Body	Port Size	Body Material

Code	Port Size
212	1 SAE

Code	Body Material
S	Steel

***Please be advised that this is a non-core line body.
 Additional lead-time and/or pricing requirements may exist when ordering.**

CV	Check Valves
SH	Shuttle Valves
LM	Load/Motor Controls
FC	Flow Controls
PC	Pressure Controls
LE	Logic Elements
DC	Directional Controls
SV	Solenoid Valves
PV	Proportional Valves
CE	Coils & Electronics
BC	Bodies & Cavities
TD	Technical Data

For additional information see Technical Tips on pages BC2-BC3.

Dimensions

Millimeters (Inches)

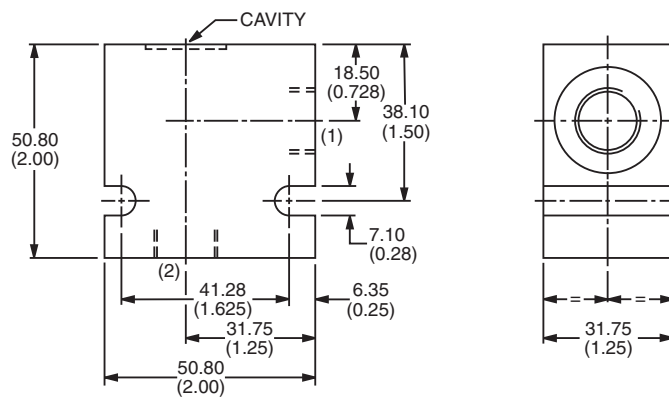
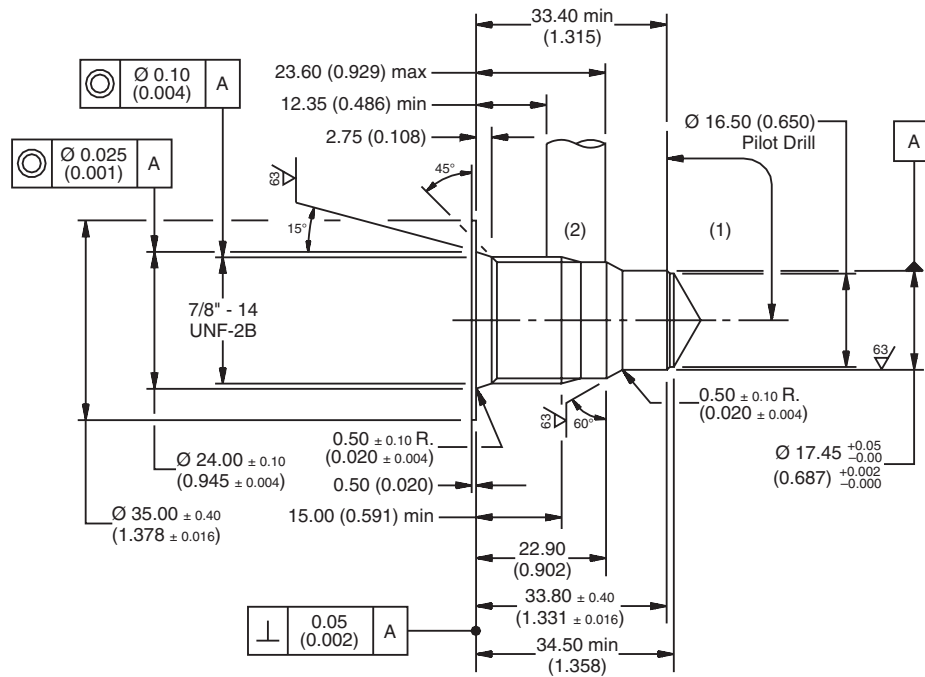

Ordering Information

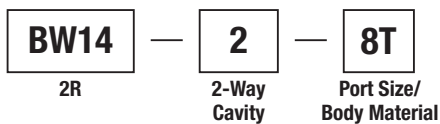

Code	Body Material
8T	SAE - 8/Steel (5000PSI)

***Please be advised that this is a non-core line body.**
Additional lead-time and/or pricing requirements may exist when ordering.

CV
Check Valves
SH
Shuttle Valves
LM
Load/Motor Controls
FC
Flow Controls
PC
Pressure Controls
LE
Logic Elements
DC
Directional Controls
SV
Solenoid Valves
PV
Proportional Valves
CE
Coils & Electronics
BC
Bodies & Cavities
TD
Technical Data

For additional information see Technical Tips on pages BC2-BC3.

Dimensions
 Millimeters (Inches)

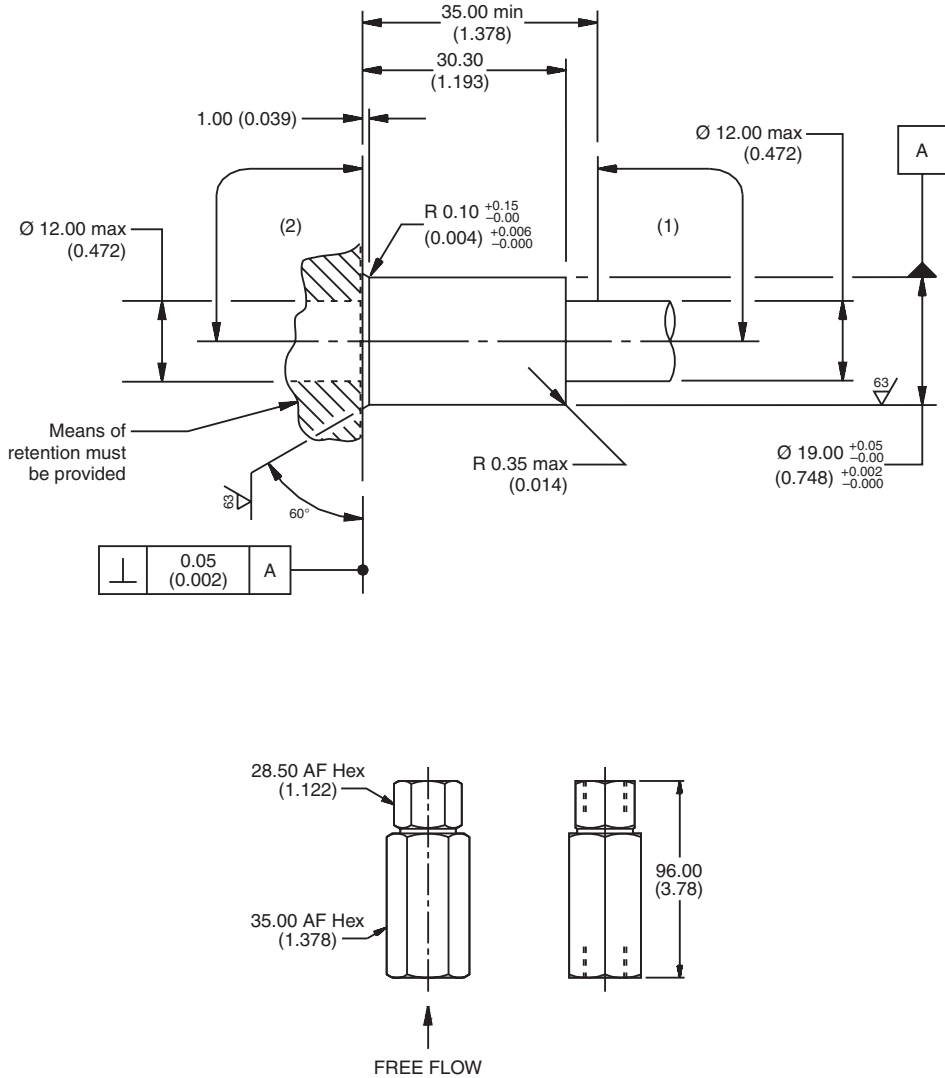

Ordering Information

LB10	220	S
Line Body	Port Size	Body Material

Code	Port Size
220	1 SAE

Code	Body Material
S	Steel

***Please be advised that this is a non-core line body.
 Additional lead-time and/or pricing requirements may exist when ordering.**

CV	Check Valves
SH	Shuttle Valves
LM	Load/Motor Controls
FC	Flow Controls
PC	Pressure Controls
LE	Logic Elements
DC	Directional Controls
SV	Solenoid Valves
PV	Proportional Valves
CE	Coils & Electronics
BC	Bodies & Cavities
TD	Technical Data

For additional information see Technical Tips on pages BC2-BC3.

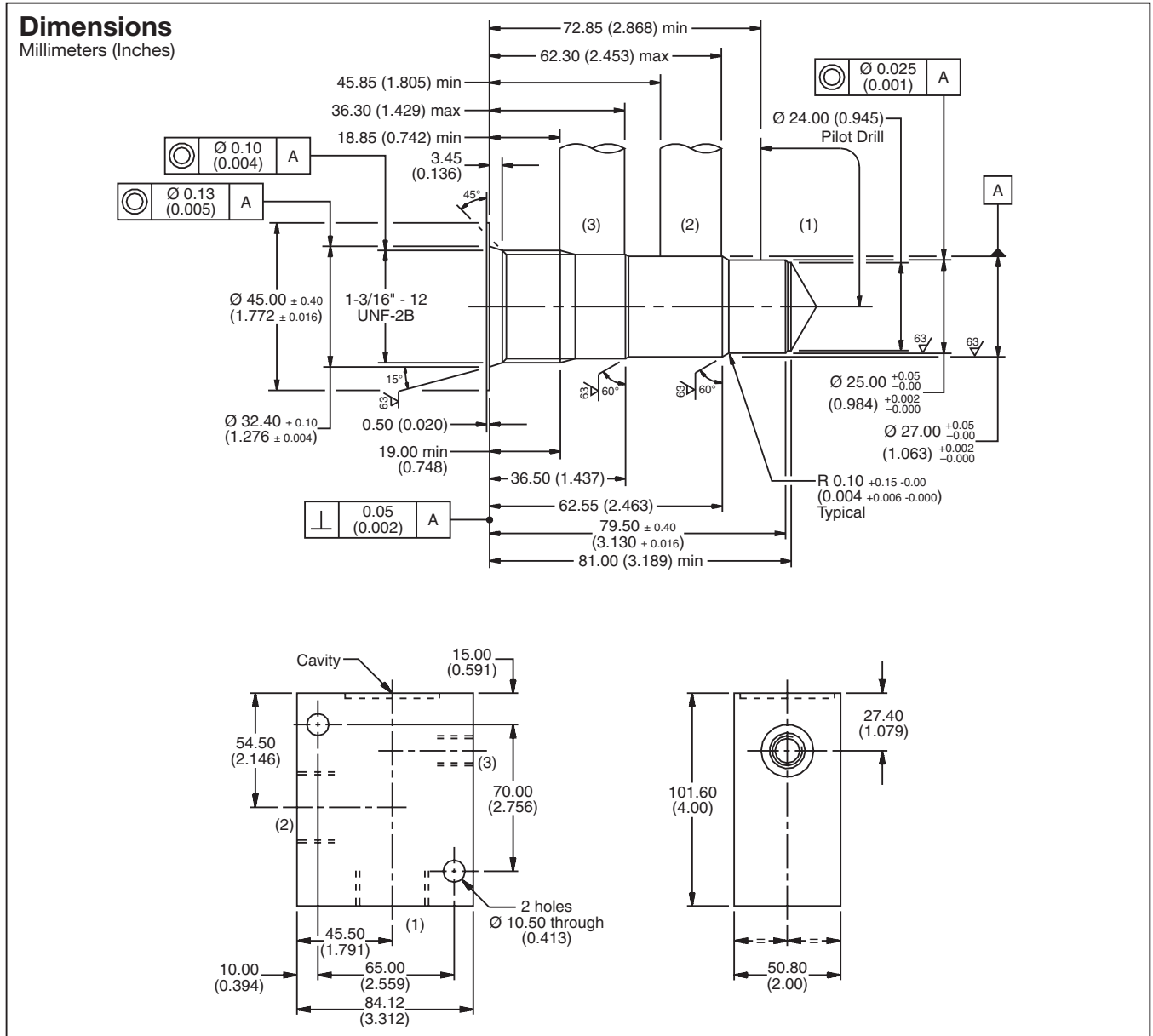

Ordering Information

LB10	066	S
Line Body	Port Size	Body Material

Code	Port Size
066	SAE16

Code	Body Material
S	Steel

***Please be advised that this is a non-core line body.**
 Additional lead-time and/or pricing requirements may exist when ordering.

CV
Check Valves
SH
Shuttle Valves
LM
Load/Motor Controls
FC
Flow Controls
PC
Pressure Controls
LE
Logic Elements
DC
Directional Controls
SV
Solenoid Valves
PV
Proportional Valves
CE
Coils & Electronics
BC
Bodies & Cavities
TD
Technical Data

For additional information see Technical Tips on pages BC2-BC3.

Dimensions

Millimeters (Inches)

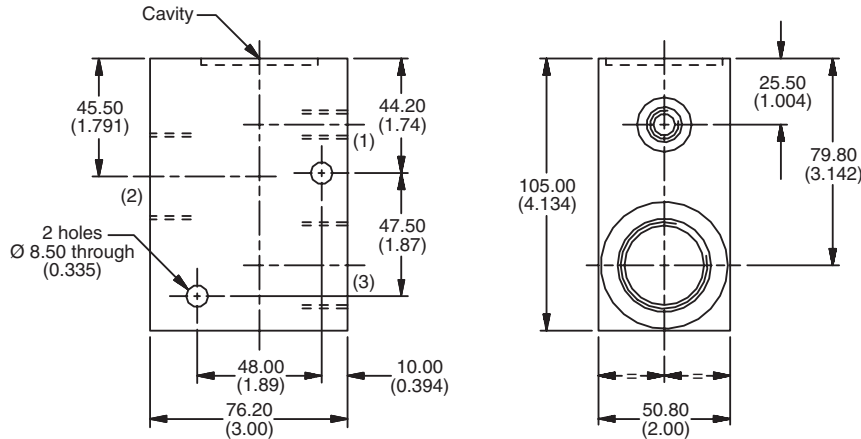
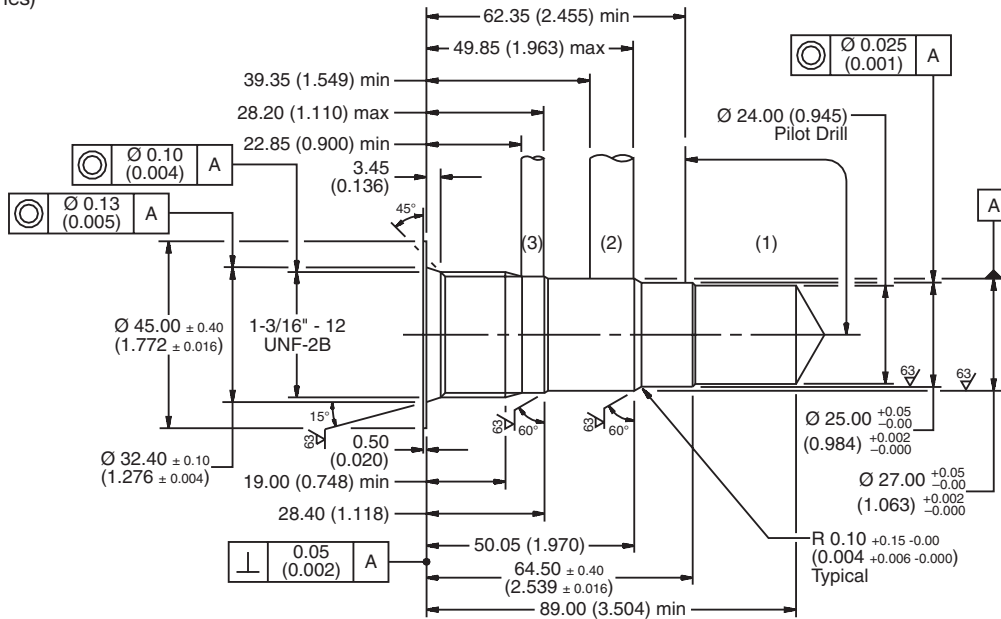

Ordering Information

LB10	069	S
Line Body	Port Size	Body Material

Code	Port Size
069	1 SAE (Main) 1/4 SAE (Aux)

Code	Body Material
S	Steel

***Please be advised that this is a non-core line body.
 Additional lead-time and/or pricing requirements may exist when ordering.**

CV
Check Valves
SH
Shuttle Valves
LM
Load/Motor Controls
FC
Flow Controls
PC
Pressure Controls
LE
Logic Elements
DC
Directional Controls
SV
Solenoid Valves
PV
Proportional Valves
CE
Coils & Electronics
BC
Bodies & Cavities
TD
Technical Data

For additional information see Technical Tips on pages BC2-BC3.

Dimensions

Millimeters (Inches)

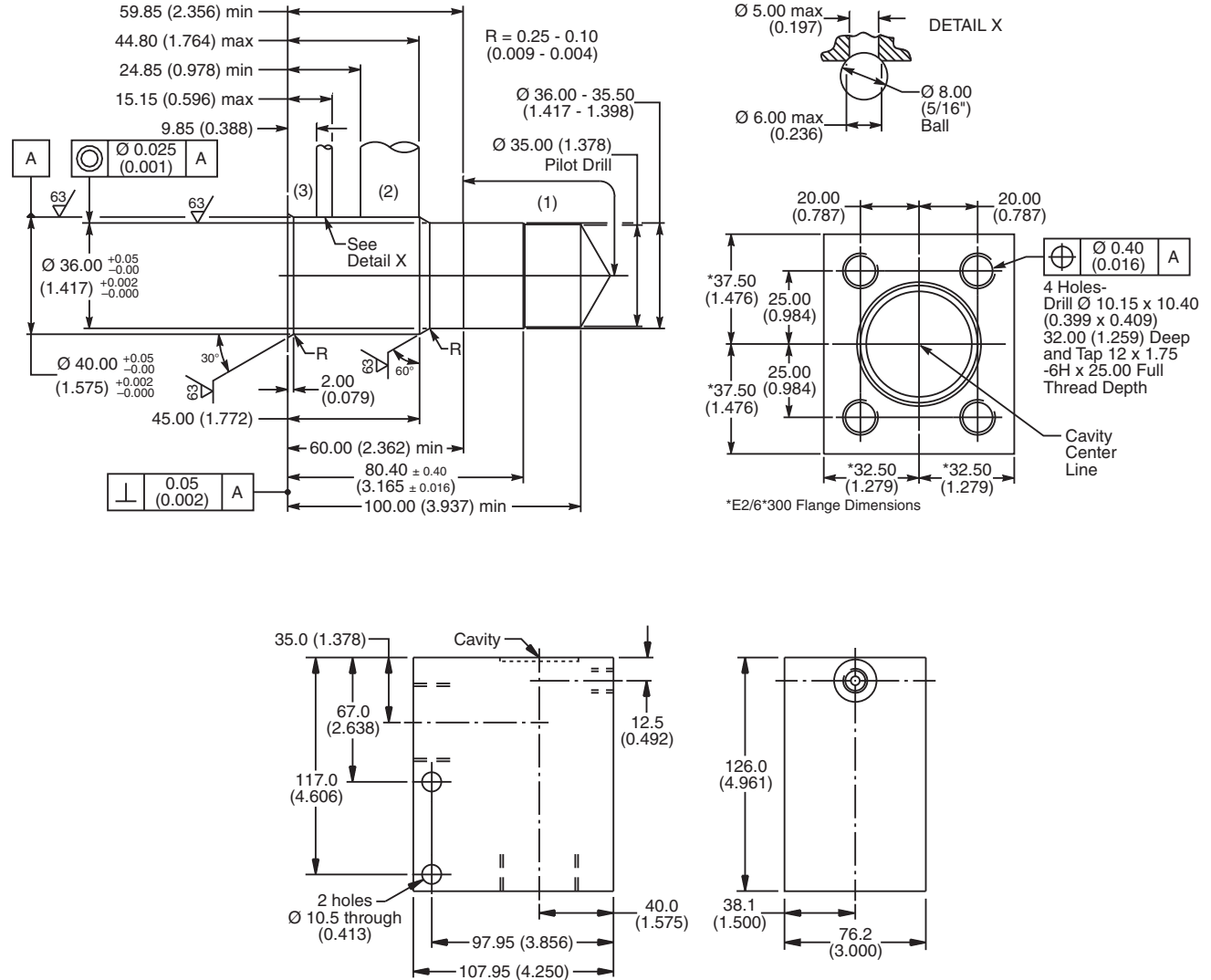

Ordering Information

LB10	089	S
Line Body	Port Size	Body Material

Code	Port Size
089	1 SAE (Main) 1/4 SAE (Aux)

Code	Body Material
S	Steel

***Please be advised that this is a non-core line body.
 Additional lead-time and/or pricing requirements may exist when ordering.**

For additional information see Technical Tips on pages BC2-BC3.

Dimensions

Millimeters (Inches)

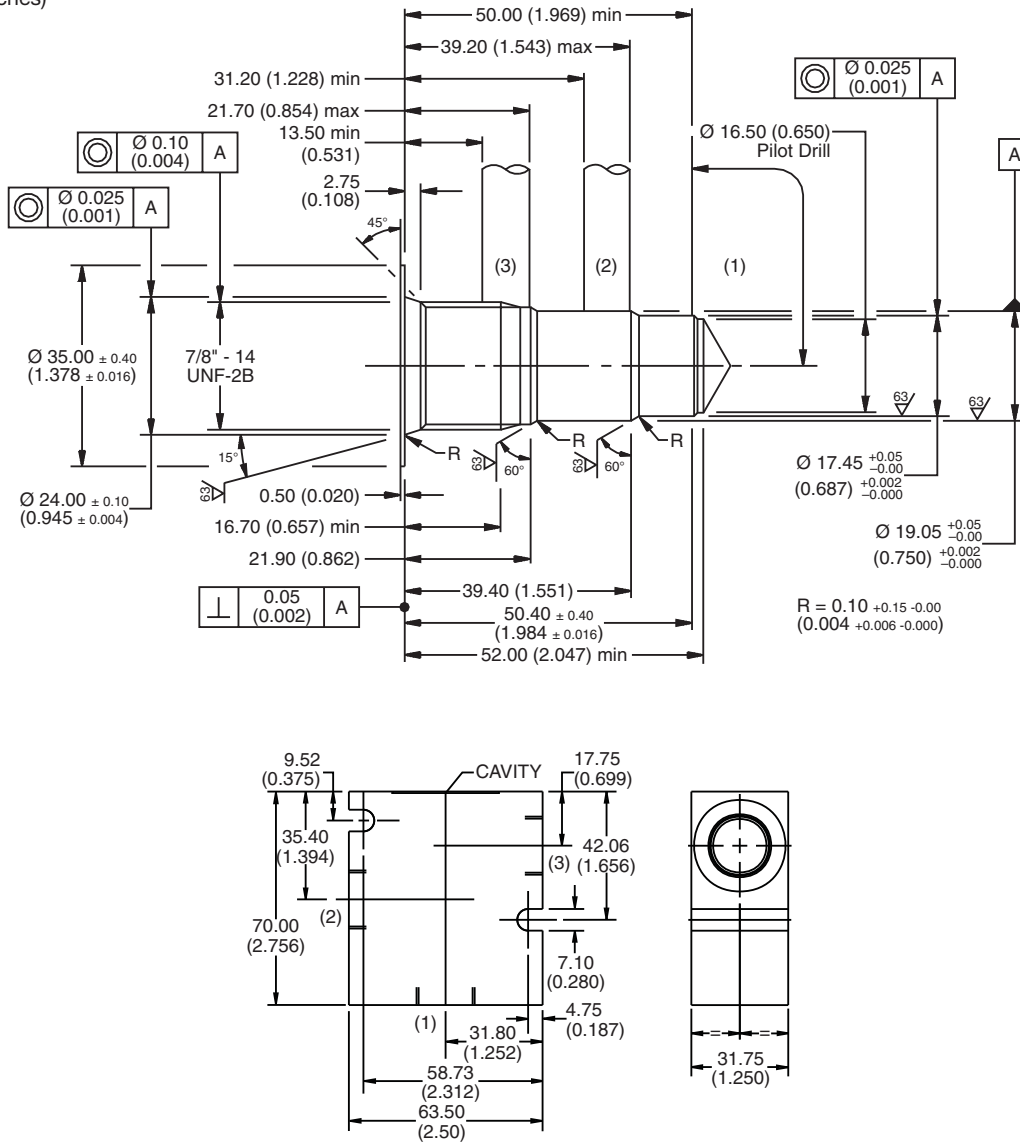

Ordering Information

LB10	553	S
Line Body	Port Size	Body Material

Code	Port Size
553	1/2 SAE

Code	Body Material
S	Steel

***Please be advised that this is a non-core line body.
 Additional lead-time and/or pricing requirements may exist when ordering.**

CV
Check Valves
SH
Shuttle Valves
LM
Load/Motor Controls
FC
Flow Controls
PC
Pressure Controls
LE
Logic Elements
DC
Directional Controls
SV
Solenoid Valves
PV
Proportional Valves
CE
Coils & Electronics
BC
Bodies & Cavities
TD
Technical Data

For additional information see Technical Tips on pages BC2-BC3.

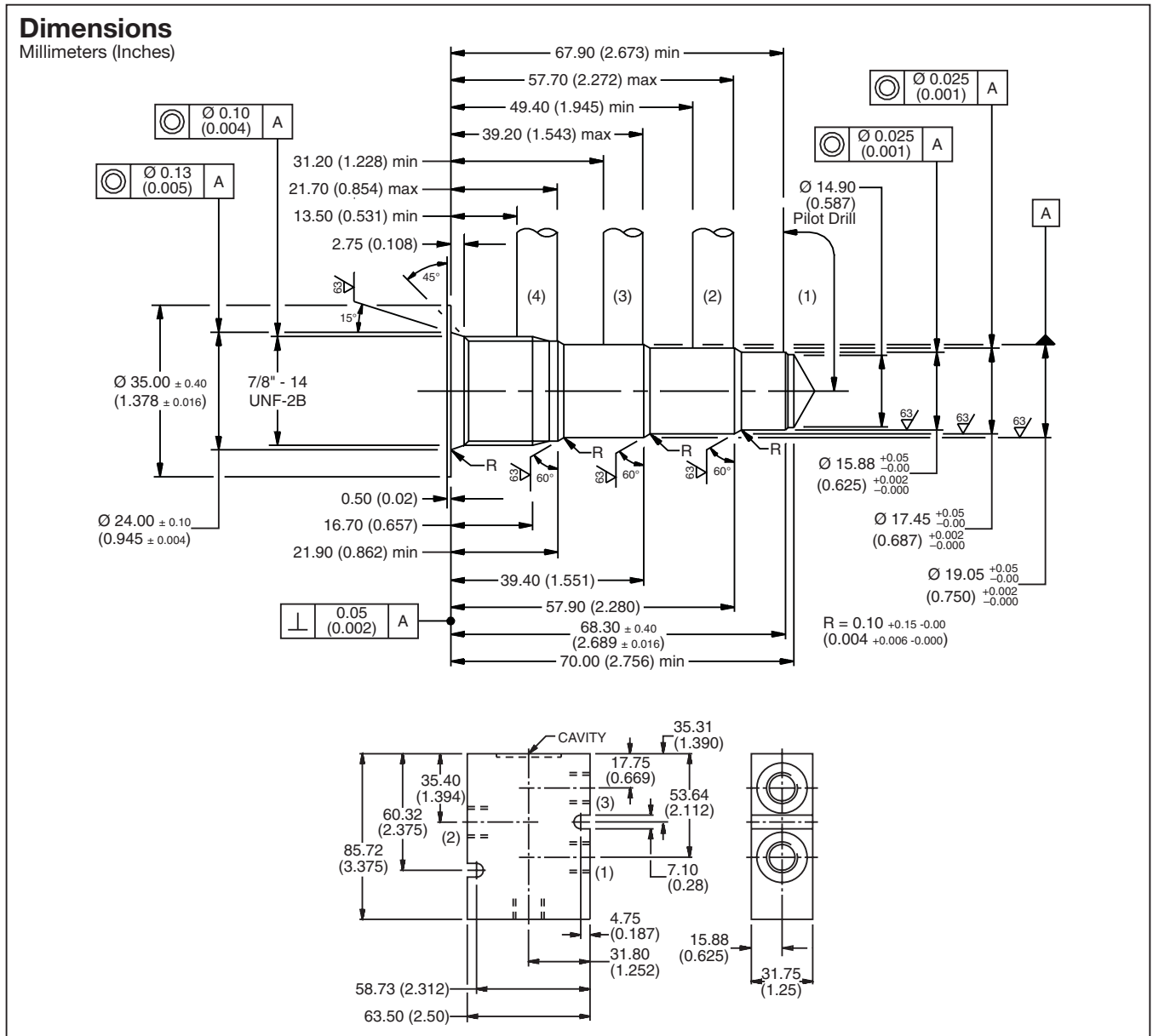

CV
Check Valves
SH
Shuttle Valves
LM
Load/Motor Controls
FC
Flow Controls
PC
Pressure Controls
LE
Logic Elements
DC
Directional Controls
SV
Solenoid Valves
PV
Proportional Valves
CE
Coils & Electronics
BC
Bodies & Cavities
TD
Technical Data

For additional information see Technical Tips on pages BC2-BC3.

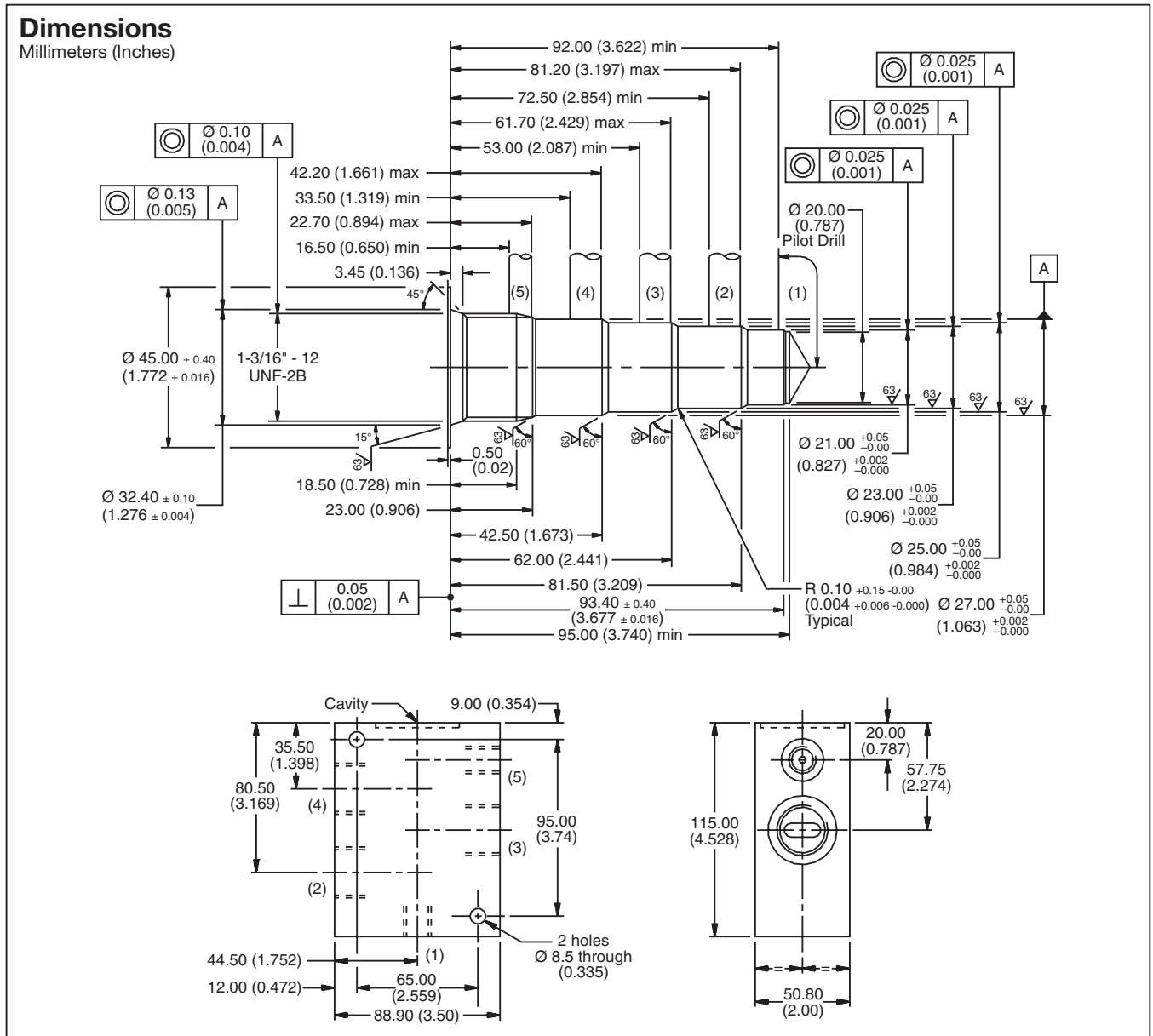

Ordering Information

LB10	321	S
Line Body	Port Size	Body Material

Code	Port Size
321	3/4 SAE (Main) 1/4 SAE (Aux)

Code	Body Material
S	Steel

***Please be advised that this is a non-core line body.
 Additional lead-time and/or pricing requirements may exist when ordering.**

CV
Check Valves
SH
Shuttle Valves
LM
Load/Motor Controls
FC
Flow Controls
PC
Pressure Controls
LE
Logic Elements
DC
Directional Controls
SV
Solenoid Valves
PV
Proportional Valves
CE
Coils & Electronics
BC
Bodies & Cavities
TD
Technical Data

For additional information see Technical Tips on pages BC2-BC3.

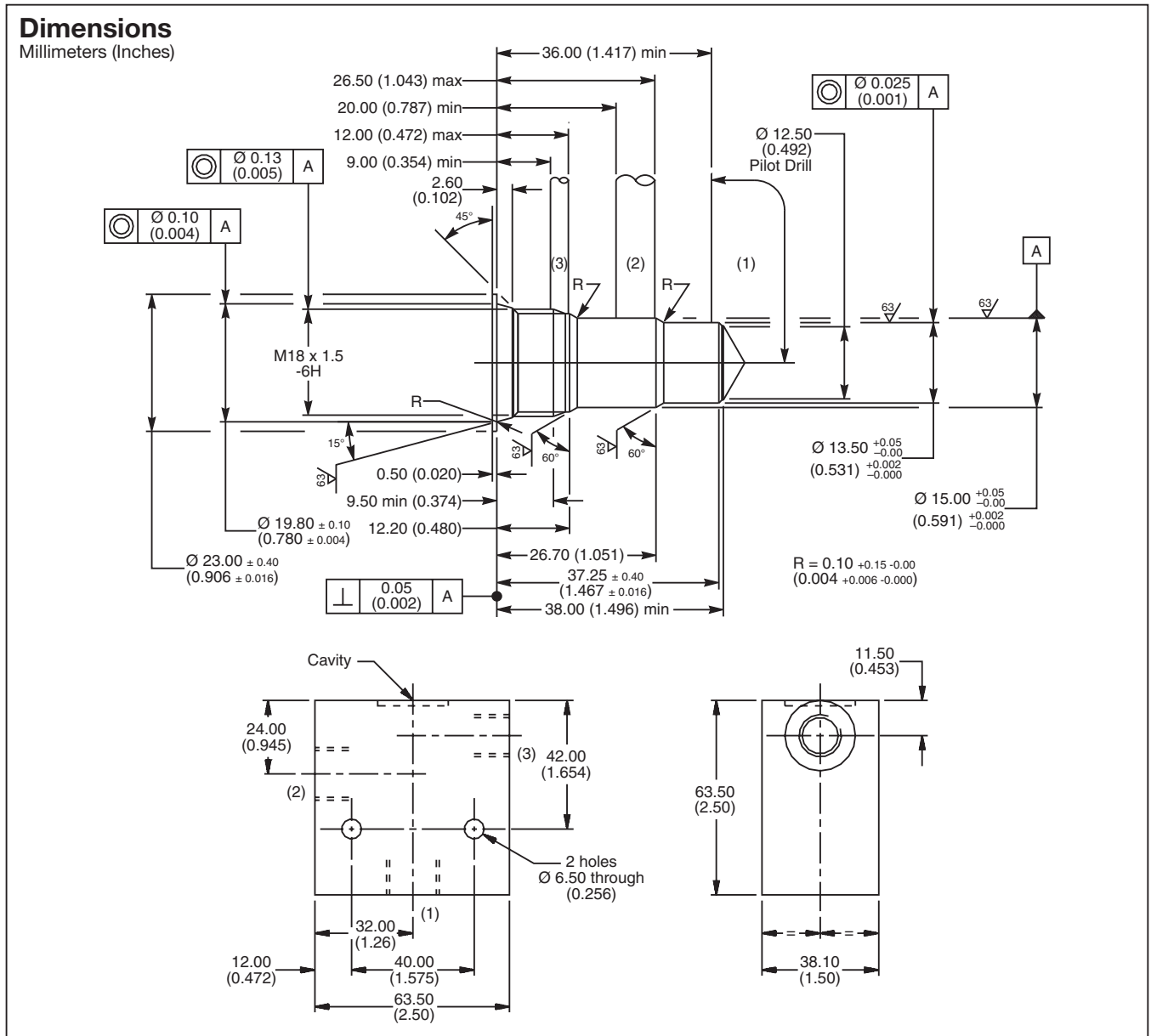

Ordering Information

LB10	318	S
Line Body	Port Size	Body Material

Code	Port Size
318	3/8 SAE (Main) 1/4 SAE (Aux)

Code	Body Material
S	Steel

***Please be advised that this is a non-core line body.
 Additional lead-time and/or pricing requirements may exist when ordering.**

CV
Check Valves
SH
Shuttle Valves
LM
Load/Motor Controls
FC
Flow Controls
PC
Pressure Controls
LE
Logic Elements
DC
Directional Controls
SV
Solenoid Valves
PV
Proportional Valves
CE
Coils & Electronics
BC
Bodies & Cavities
TD
Technical Data

For additional information see Technical Tips on pages BC2-BC3.

Dimensions

Millimeters (Inches)

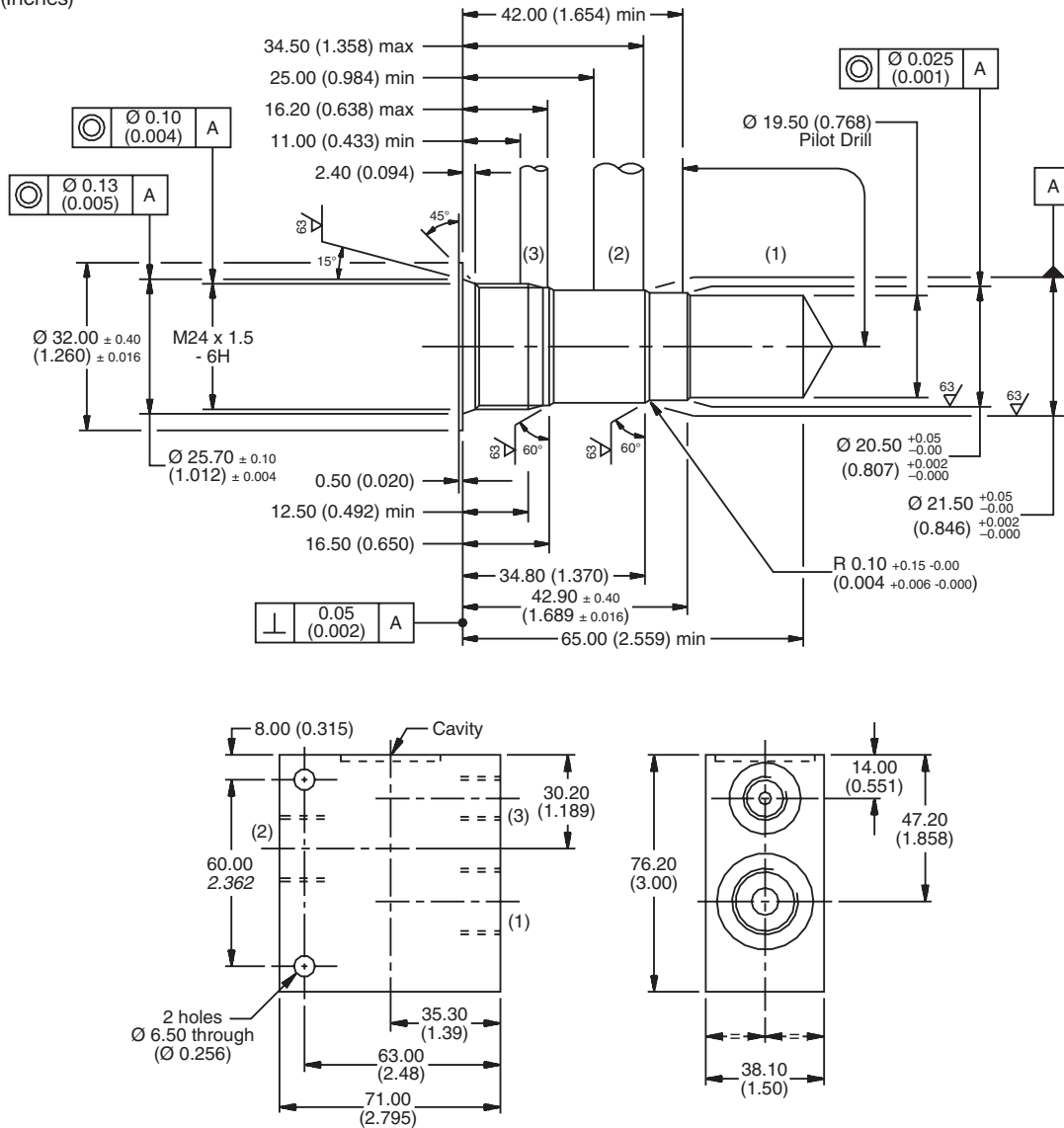

Ordering Information

LB10	253	S
Line Body	Port Size	Body Material

Code	Port Size
253	1-1/4 SAE (Main) 3/8 SAE (Aux)

Code	Body Material
S	Steel

***Please be advised that this is a non-core line body.
 Additional lead-time and/or pricing requirements may exist when ordering.**

CV
Check Valves
SH
Shuttle Valves
LM
Load/Motor Controls
FC
Flow Controls
PC
Pressure Controls
LE
Logic Elements
DC
Directional Controls
SV
Solenoid Valves
PV
Proportional Valves
CE
Coils & Electronics
BC
Bodies & Cavities
TD
Technical Data

DESCRIPTION	PAGE NO.
Basic Hydraulic Formulas.....	TD2
Ratings and Testing	TD2
Temperature Ratings.....	TD2
Viscosity	TD2
Pressure Ratings.....	TD2
Thermal Shock	TD2
Service and Components	TD2
Limitations in Use	TD2
Seal Material Selection	TD3
Hydraulic Fluids	TD4
Hydraulic Filtration.....	TD4
Application of Product.....	TD4

CV
Check Valves
SH
Shuttle Valves
LM
Load/Motor Controls
FC
Flow Controls
PC
Pressure Controls
LE
Logic Elements
DC
Directional Controls
SV
Solenoid Valves
PV
Proportional Valves
CE
Coils & Electronics
BC
Bodies & Cavities
TD
Technical Data

INTRODUCTION

In this section you will find a variety of technical information pertinent to general hydraulics as well as cartridge valve technology.

HYDRAULIC FORMULAS

Below are a few of the common hydraulic formulas to assist you in calculating the requirements for your system:

Voltage = *Current* × *Resistance*

Flow = *Volume* ÷ *Unit of Time*

Pressure = *Force* ÷ *Area*

Horsepower = *Flow* × *Pressure* ÷ (1714 × *Efficiency*)

Hydraulic power (kW) = $\frac{\Delta p \text{ (Bar)} \times \text{flow rate (LPM)}}{600}$

where Δp = pressure drop

Hydraulic power (HP) = $\frac{\Delta p \text{ (PSI)} \times \text{flow rate (GPM)}}{1714}$

RATINGS & TESTING

All Parker cartridge valve products have been performance tested with the results shown on the individual valve catalog pages. The performance data shown represents typical operation characteristics of the product. In addition, our valves are endurance tested. Validation is conducted by testing or similarity in designs. **Note:** Not every cartridge option is endurance tested. In other words, one three way spool is endurance tested, and the others are assumed by similarity.

TEMPERATURE RATINGS

Product operating limits are broadly in the range -30°C to 150°C (-20°F to 300°F) but satisfactory operation within the specification may not be accomplished. Leakage and response will be affected when used at temperature extremes and it is the user’s responsibility to determine acceptability at these levels.

Seals used in these products generally have the following temperature limitations:

Nitrile (Buna N)	-34°C to 121°C (-30°F to 250°F)
Fluorocarbon	-26°C to 204°C (-15°F to 400°F)
Hytrell	-54°C to 135°C (-65°F to 275°F)
GTPFE	-30°C to 150°C (-20°F to 300°F)
4301 Polyurethane	-37°C to 93°C (-35°F to 200°F)

VISCOSITY

Catalog data is from tests conducted on mineral oil at a viscosity of 32 cSt (150 SSU) using an ISO 32 fluid at 100 degrees F.

Product should ideally be used at viscosities in the range of 15 to 50 cSt (80 to 230 SSU).

Product will perform with reduced efficiency in the ranges, 5 to 15 cSt (42 to 80 SSU) and 50 to 500 cSt (230 to 2300 SSU). These extreme conditions must be evaluated by the user to establish suitability of the product’s performance.

PRESSURE RATINGS

Unless otherwise stated, all Parker cartridges have a continuous duty pressure rating as shown in the catalog. All pressure ratings are based on the cartridge valve only. Exposure to elevated pressures may affect the performance and fatigue life of the product. The material chosen for the body or carrier may affect the pressure rating we recommend. Parker does not recommend the use of cartridge valves in aluminum bodies at pressures above 207 bar (3000 psi).

THERMAL SHOCK

It is unreasonable to expect product to withstand rapid temperature changes - this could affect both performance and life and care should be taken to protect the product from such situations.

SERVICE & COMPONENTS

One of the advantages of integrated hydraulic circuits is their serviceability. Should a valve need to be replaced for any reason, a user only needs to unscrew the valve from the manifold and screw the replacement into the cavity. As such, there are few replacement parts available for the Parker cartridge products. As with any hydraulic system, the operator should bleed off any trapped pressure and consult machine service manuals prior to service. Parker does not offer any service parts for internal components, but external components such as coils, knobs, and seals are available.

LIMITATIONS IN USE

Parker cartridge valves are designed for a wide variety of industrial and mobile applications. Despite their flexibility, Parker Hannifin does not recommend or support the use of our cartridge valves in any on-highway or aerospace applications. We also do not recommend our products for use in the transport of explosive products or in hazardous environments.

CV	Check Valves
SH	Shuttle Valves
LM	Load/Motor Controls
FC	Flow Controls
PC	Pressure Controls
LE	Logic Elements
DC	Directional Controls
SV	Solenoid Valves
PV	Proportional Valves
CE	Coils & Electronics
BC	Bodies & Cavities
TD	Technical Data



SEAL MATERIAL SELECTION

You should match the seal compatibility to the temperature and fluid being used in your application. Parker offers three seal materials to meet your application requirements. Parker's standard material is a 4301 Polyurethane RESILON™ material "D"-Ring. We also offer Fluorocarbon and Nitrile seals. A brief synopsis of each seal material is given below to help you choose the best seal for your application.

"D"-Ring (4301 Polyurethane RESILON™ Material)

The "D"-Ring is the standard seal material on the Winner's Circle threaded cartridge valves. The "D"-Ring is molded of a special 4301 Polyurethane RESILON™. Polyurethane materials exhibit better wear resistance and tensile strength than standard Nitrile or Fluorocarbon material. In addition, it has an excellent resistance to compression set. This increased strength eliminates the need for back-rings and simplifies installation.

The 4301 compound is a Parker exclusive material designed to prevent hydrolysis at high temperatures.

Thus, the "D"-Ring outperforms standard polyurethane o-rings, especially when using high water content fluids at elevated temperatures. The "D"-Ring is compatible with most water-glycol, water/oil emulsions, and high grade petroleum based hydraulic fluids at temperatures between -37°C to +93°C (-35°F to +200°F)

The unique shape of the Parker "D"-Ring also provides a variety of design advantages. The seal is molded into a "D" shape where the seal is higher in the middle and lower on the ends. This prevents the seal edge from folding over on a corner inside the manifold during installation. In addition, this design has a minimal lip, thus, friction is reduced. Another unique feature of the "D"-Ring is its symmetrical design, resulting in no performance degradation from the reverse direction, or worry of backward installation. The "D"-Ring is also equipped with "pressure pedestals" to reduce the effects of "blow-by" common in reverse cycling. The pressure pedestals increase the sealing capability of the "D"-Ring, by reducing the radial pressure forces that compress the sealing face of the o-ring. The drawing below depicts the shape and highlights the features.

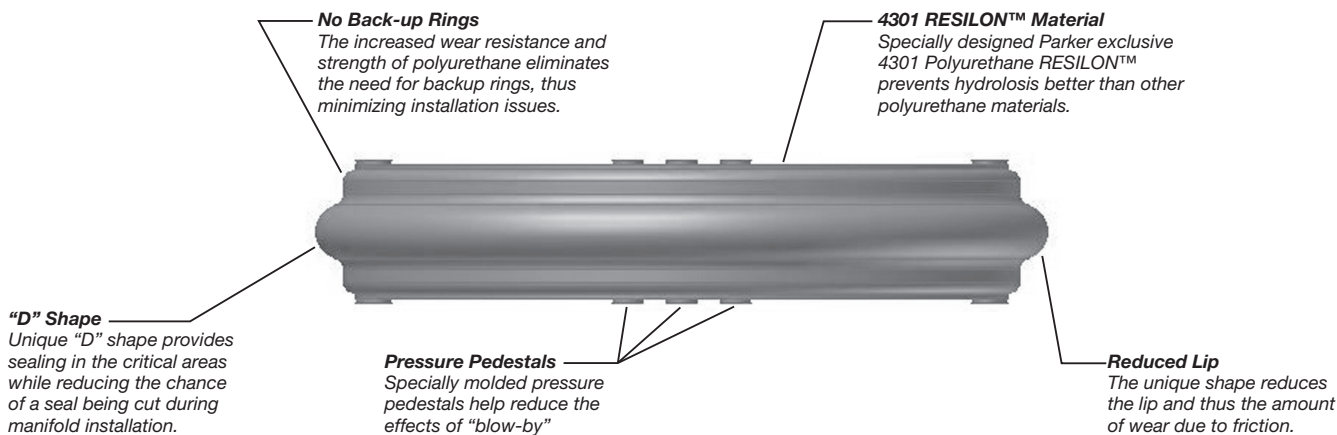

Nitrile

Nitrile o-rings are also compatible with most water-glycol, water/oil emulsions, and high grade petroleum based hydraulic fluids. Parker only recommends Nitrile o-rings for temperatures between -34°C to +121°C (-30°F to +250°F). Nitrile o-rings do require a full back-up ring, or two half back-ups.

Fluorocarbon

Fluorocarbon o-rings are compatible with most phosphate ester fluids and phosphate ester blends. Parker only recommends Fluorocarbon seals for temperatures between -26°C to +204°C (-15°F to +400°F). Fluorocarbon o-rings do require a full back-up ring, or two half back-ups.

CV
Check Valves
SH
Shuttle Valves
LM
Load/Motor Controls
FC
Flow Controls
PC
Pressure Controls
LE
Logic Elements
DC
Directional Controls
SV
Solenoid Valves
PV
Proportional Valves
CE
Coils & Electronics
BC
Bodies & Cavities
TD
Technical Data

HYDRAULIC FLUIDS

Parker recommends using top-quality mineral based or synthetic hydraulic fluids with lubricating properties at viscosities of 45 to 2000 SSU (6 to 420 cSt) at 38°C (100°F). The absolute viscosity range 80 to 1000 SSU (16 to 220 cSt.). Fluids should have high anti-wear characteristics and be treated to protect against oxidation.

HYDRAULIC FILTRATION

Hydraulic systems that include Parker valves should be carefully protected against fluid contamination. The proper cleanliness level for Parker cartridge valves should be maintained at an ISO cleanliness level of 18/16/13.

75% of all system failures are a direct result of contamination. Contamination interferes with four functions of hydraulic fluids.

1. To act as an energy transmission medium.
2. To lubricate internal moving parts of components.
3. To act a heat transfer medium.
4. To seal clearances between moving components.

A properly selected filter will provide adequate protection and reduce operating cost. This is achieved by increasing the expected life of the valves and reducing the cost of maintenance and repairs. Operation will be smoother and more precise.

There is no direct correlation between using a specific ISO cleanliness classification. Numerous other variables should be considered such as particulate ingestion, actual flow through filters, and filter location.

A number of interrelated system factors combine to determine proper media and filter combinations. To accurately determine which combination is ideal for your system, all these factors need to be accounted for. With the development of filtration sizing software such as Parker inPHorm, this information can be used to compute the optimal selection. In many instances the information available may be limited. In these cases, “rules of thumb” based on empirical data and proven examples are applied to get an initial starting point.

APPLICATION OF PRODUCT

CAUTION - It is important to note that the Parker Hydraulic Cartridge Systems Division makes a variety of valves, many of which fit into the same cavity. However, their functionality may differ considerably from one valve type to another. Accordingly fit interchangeability does not necessarily mean form or function interchangeability. Users should ensure that the appropriate valve is installed in the cavity by cross checking the part number stamped on the valve with that published in approved service literature or in the installation drawing.

CV	Check Valves
SH	Shuttle Valves
LM	Load/Motor Controls
FC	Flow Controls
PC	Pressure Controls
LE	Logic Elements
DC	Directional Controls
SV	Solenoid Valves
PV	Proportional Valves
CE	Coils & Electronics
BC	Bodies & Cavities
TD	Technical Data

Parker Hannifin - Hydraulic Valve Systems and Mobile Systems Division - Europe

Parker HVS and MSDE Divisions are leaders in the cartridge valve and custom manifold industry, serving both the mobile and industrial machine markets.

Our team of application engineers and manufacturers consistently challenge valve standards to achieve the most efficient and flexible designs. They work hard to provide the highest level of customer satisfaction and support. Discover how Parker HVS and MSDE can be the ONE source for all your hydraulic cartridge and manifold needs.

Have questions? Visit us at www.parker.com

Parker Hannifin Corporation
Hydraulic Valve Systems
520 Ternes Avenue
Elyria, Ohio 44036-4026
United States
Ph: (440) 366 5100
hvd.support@support.parker.com
www.parker.com/hvs

Parker Hannifin Corporation
**Mobile Hydraulic Systems
Division Europe**
Parker Hannifin Manufacturing LTD
Blacknell Lane - Crewkerne
TA18 8LL
UK
Tel: +44 (0) 01460 271800
MSDE.Crewkerne.ProductSupport@support.parker.com
www.parker.com/msde

Parker Hannifin Corporation
Corporate Headquarters
6035 Parkland Blvd
Cleveland, OH 44124
USA
Tel: 216-896-3000
Fax: 216-896-4000

For information, please contact Parker toll free at 1-800-C-PARKER (1-800-272-7537).
Outside of North America contact us via Freephone at 00800 27 27 5374.

