

# W-A2M20 2-STEP MOTION TYPE

MULTI-APERTURE, IRREGULAR ORIFICE/  
ANALOG ADJUSTABLE TYPE



## 2-STEP MOTION, BODY-SCREWED TYPE SHOCK ABSORBER WITH SMALL, LIGHT, ANALOG ADJUSTABLE TYPE

- Shock absorber of energy absorption adjustable type. The first half and last half of stroke indicates the energy absorption characteristics of multi-aperture orifice and single aperture orifice respectively.
- With the mounting thread provided on the outer surface of body, the handling is easy as if bolt is mounted.
- Ideal for the shock absorption with air cylinder.

## PRECAUTIONS FOR HANDLING

- For mounting MINI-SOFTER, the impact load shall be applied at the center line of rod. The impact angle shall be set at less than  $\pm 0.05$ rad against the center line of rod.
- Do not use MINI-SOFTER as stopper.
- When using, the auxiliary stopper nut shall be applied as much as possible.
- Use at the location with ambient temperature of  $-5 \sim +70$  °C.
- Do not damage the piston rod. The lowering of durability and the inferiority of return may be caused.
- Do not use the piston rod in such environment that cutting oil and other liquids may be adhered.
- Do not use over 2 MINI-SOFTERS in parallel.
- Nut clamp torque is 30N·m.

## ADJUSTMENT METHOD

As shown below, turn the adjusting dial with fingers. For adjustment, set mark at strong, medium, weak of nameplate according to requirement.

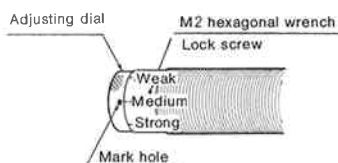

With the analog method adopted, the setting at the intermediate position is available. After the completion of adjustment, the lock screw shall be locked.

## SPECIFICATIONS

| Code                            |                     | W-A2M20N016SD<br>(Fundamental type)             | W-A2M20S016SD-C<br>(With cap) |
|---------------------------------|---------------------|---|-------------------------------|
| Max. energy absorption          | J                   | 5.88~29.4                                       |                               |
| Stroke                          | mm                  | 16  |                               |
| Equivalent weight range         | kg                  | 200   |                               |
| (※1) Max. energy capacity       | J/min               | 343   |                               |
| Impact speed range              | m/s                 | 2 and less                                      |                               |
| (※3) Max. resisting force value | N                   | 4900  |                               |
| (※2) Rod return force           | N                   | 18.0  |                               |
| (※2) Rod return time            | s                   | 0.5   |                               |
| Max. operating cycle            | cycle/min           | 60  |                               |
| Operating temp. range           | °C                  | $-5 \sim +70$ (at non-freezing condition)       |                               |
| Weight<br>g                     | Body                | 180   | 202                           |
|                                 | Mounting attachment | FA attachment: 110                              |                               |
| Accessories                     |                     | Auxiliary stopper nut • Adapter for declination |                               |

(※1) The max. energy capacity per minute in the table is shown at the ambient temperature of 26.7 °C.

The max. energy capacity per minute at the ambient temperature T(°C) mentioned as  $E_2$ (J/min) is calculated according to the following formula:

$$E_2 = \frac{(82.2 - T)}{55.5} \times (\text{Max. energy capacity per min. in table})$$

(※2) It indicates the maximum value when stroke 16mm is pushed.

(※3) Max. resisting force value is the value in case that appropriate adjustment has been conducted.

## DIMENSIONAL DRAWINGS

Unit:mm

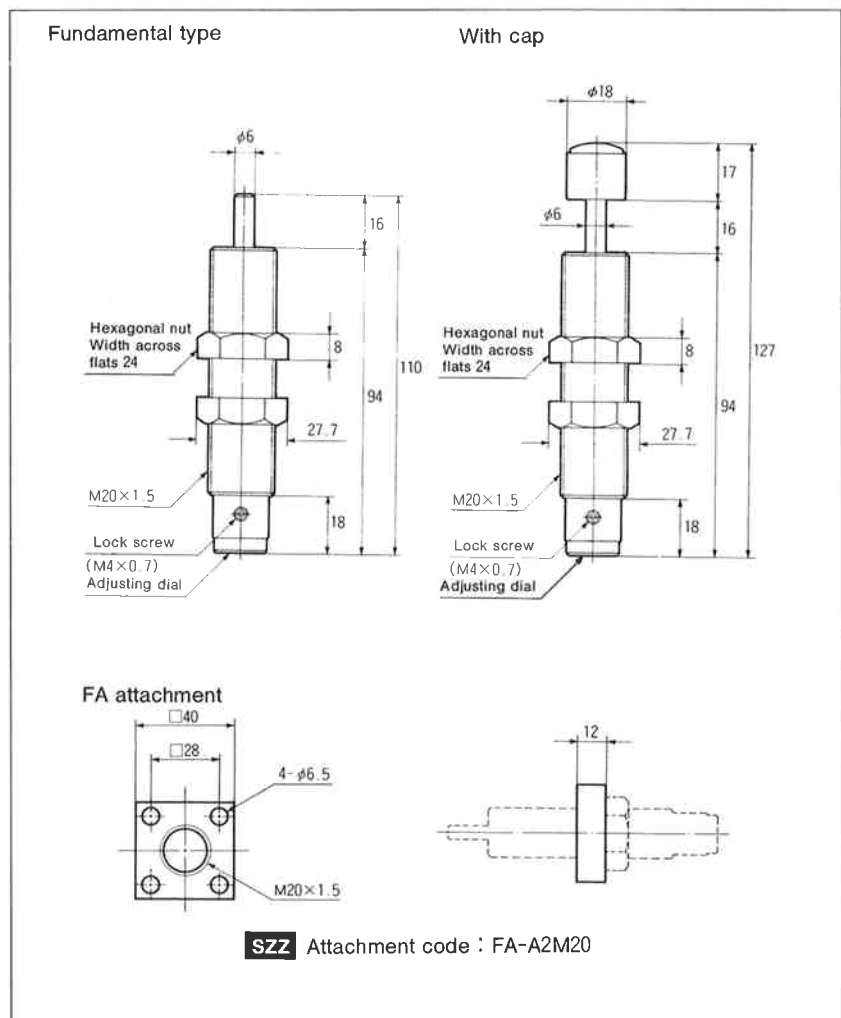

\* For the dimensional drawings of auxiliary stopper nut and adapter for declination, refer to Accessories on Page 37.