

Suitable for clamp of work.

- Excellent in durability by setting cam on bush and few plays at arm end.
Also roller structure enable smooth operation.
- Usable even in adverse environment of plenty of dust by adopting strong scraper.
- The same dimensions on mounting pitch as our slim pneumatic cylinder, 10S-6 series.



Standard Specifications

Action style	Double-acting		
Structure	Standard type · Switch set		
Cylinder bore (mm)	φ 40	φ 50	φ 63
Theoretical clamp force (N) *Note.1	527	825	1401
Allowable moment (N · m) *Note.2	47	107	182
Rotating stroke	20mm		
Straight stroke	10mm · 20mm		
Non-rotation accuracy at straight stroke	±0.7°	±0.5°	±0.5°
Rotating angle	90°		
Rotating angle tolerance	±5°	±7°	±7°
Rotating direction *Note.3	Right · Left		
Working fluids	Air		
Lubrication	Not necessary (but possible)		
Operating pressure range	0.1 to 1MPa		
Proof test pressure	1.5MPa		
Operating temperature range	Standard type: -10 to +70°C Switch set: 0 to +70°C (Do not use when frozen)		
Cushion mechanism	With cushion pad on both ends		
Tolerance for thread	JIS 6H/6g		
Mounting style	SD · FA · FB		

Note.1) Value at allowable pressure of 0.5MPa

Note.2) Max. bending moment applied to piston rod

Note.3) Rotating direction from rod side when piston rod is pulled.

Theoretical Clamp Force Table

Unit: N

Bore	Working direction	Operating Pressure (MPa)									
		0.1	0.2	0.3	0.4	0.5	0.6	0.7	0.8	0.9	1.0
φ 40	Extend side	126	251	377	503	628	754	880	1005	1131	1257
	Retract side	106	211	317	422	528	633	739	844	950	1056
φ 50	Extend side	196	393	589	785	982	1178	1374	1571	1767	1963
	Retract side	165	330	495	660	825	990	1155	1319	1484	1649
φ 63	Extend side	312	623	935	1247	1559	1870	2182	2494	2806	3117
	Retract side	280	561	841	1121	1402	1682	1962	2242	2523	2803

Product Lineup

Unit:mm

Action style	Structure	Option	φ40	φ50	φ63
Double-acting	Standard RCA2	Without arm	●	●	●
		With arm	●	●	●
	Switch set RCA2	Without arm	●	●	●
		With arm	●	●	●

Working description

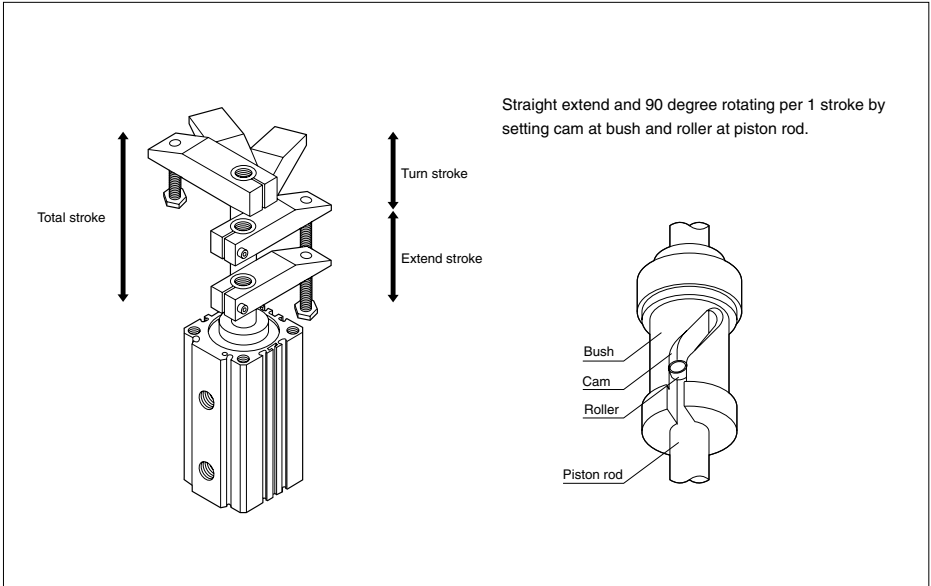

Weight Table

Unit: g

Bore	Piping position	Basic weight		Rod end square additional weight	Arm weight	Flange weight	Switch weight (1 pease)	
		10 strokes	20 strokes				1m Cord	3m Cord
φ 40	Side port	1130	1280	-20	210	290	15	60
φ 50	Side port	1915	2165	-50	480	450		
φ 63	Side port	2510	2800	-50	480	610		

Calculation formula Cylinder weight(g) = Basic weight + Arm weight + (Switch weight x Switch quantity) + Flange weight

Calculation example Bore φ 50, Straight stroke 10mm, With arm, PD12L1(with cord 1m) x 2pcs, FA

$$1,915 + 480 + (15 \times 2) + 450 = 2,875g$$

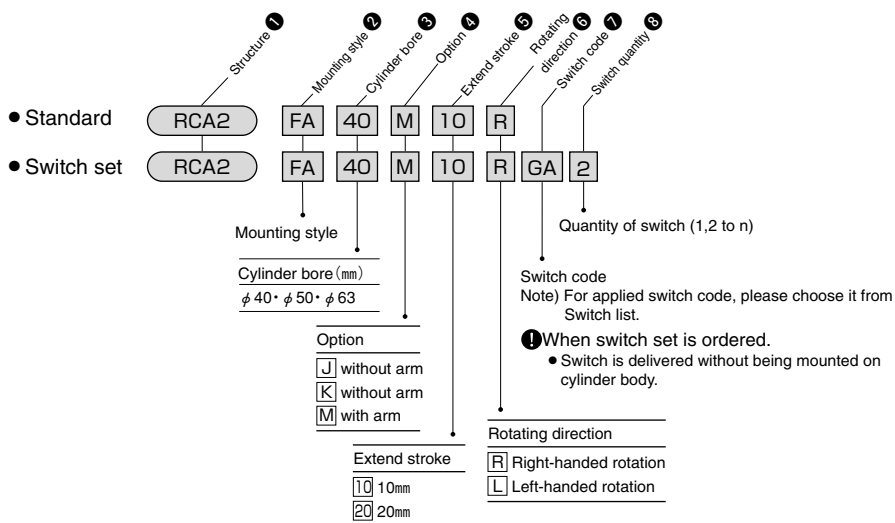

★ About rotation direction

In order to choose rotating direction of piston rod, please look at rotary clamp from rod side and choose it when piston rod is retracted.

Choose R in case of right-handed rotation (clockwise), and choose L in case of left-handed rotation (counterclockwise).

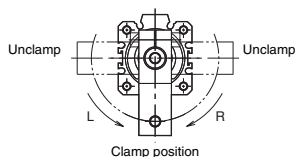

★ Option

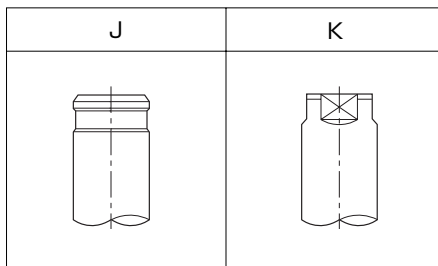

Mounting Accessories Parts Code

Bore (mm)	FA ; FB style
$\phi 40$	MAS5-FA040
$\phi 50$	MAS5-FA050
$\phi 63$	MAS5-FA063
Remarks	With 4 pcs of mounting screw

Optional Parts Code (Arm)

Bore (mm)	Arm code
$\phi 40$	RCA-M040
$\phi 50$	RCA-M050
$\phi 63$	RCA-M063

Switch List

Type	Switch code	Load voltage range	Load current range	Protective circuit	Indicating lamp	Wiring method	Cord length	Classification
Contact	GA PD12L1	DC24V AC110V	DC:2.5~40mA AC:2.5~20mA	None	None	0.2mm ² 2-core dimension ϕ 2.6 Rear wiring	1 m	General
	GB PD12L3						3 m	
	GC PD11L1		DC:5~40mA AC:5~20mA		LED (Light lights up during ON)	0.2mm ² 2-core dimension ϕ 2.6 Rear wiring	1 m	
	GD PD11L3						3 m	
	GE PD32L1		DC:2.5~40mA AC:2.5~20mA		None	0.2mm ² 2-core dimension ϕ 2.6 Upper wiring	1 m	
	GF PD32L3						3 m	
	GG PD31L1		DC:5~40mA AC:5~20mA		LED (Light lights up during ON)	0.2mm ² 2-core dimension ϕ 2.6 Upper wiring	1 m	
	GH PD31L3						3 m	
Noncontact	GJ PD14L1	DC10~28V	5~20mA	Present	LED (Light lights up during ON)	0.2mm ² 2-core dimension ϕ 2.6 Rear wiring	1 m	General
	GK PD14L3	DC28V or less	0.1~40mA				3 m	
	GL PD13L1				DC10~28V	5~20mA	LED (Light lights up during ON)	
	GM PD13L3	3 m						
	GN PE34L1	DC10~28V	5~20mA		LED (Light lights up during ON)	0.2mm ² 2-core dimension ϕ 2.6 Upper wiring	1 m	
	GP PE34L3						3 m	
	GR PE33L1	DC28V or less	0.1~40mA		LED (Light lights up during ON)	0.15mm ² 3-core dimension ϕ 2.6 Upper wiring	1 m	
	GS PE33L3						3 m	

Note) ● For the switches without a protective circuit, be sure to provide the protective circuit (SK-100) with load devices when using induction load devices (relay, etc.)

● When using switches by a series connection, we recommend you to use AND unit (AU series).

● General type

PD · PE style switch



Mounting style

SD (Standard)

FA (Rod side rectangle flange style)

FB (Head side rectangle flange style)

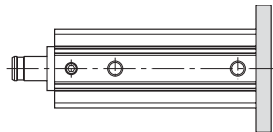
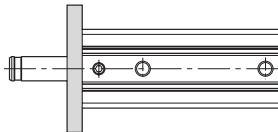
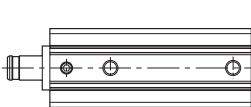

RCA2/TRCA2 Bore CAD/DATA is available.



SD

RCA2 SD Bore Option Extend stroke Rotating direction

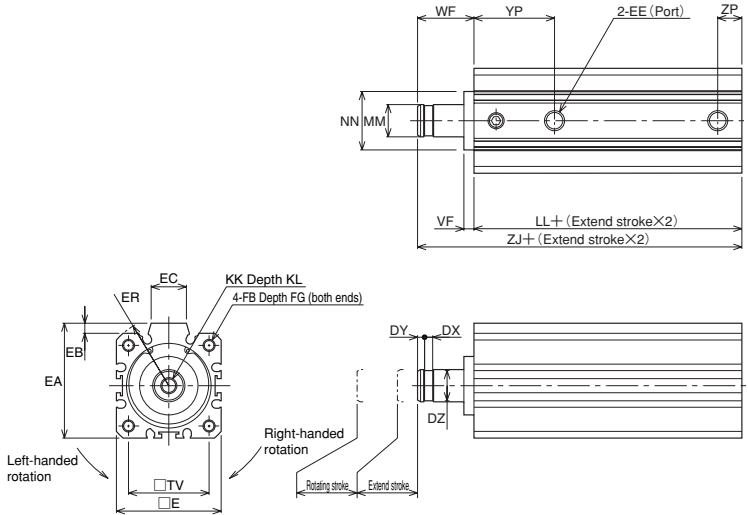

Note) For Rod end option K, please refer to the page for Rod end Square.

FA

RCA2/TRCA2 Bore Rod end

RCA2 FA Bore Option Extend stroke Rotating direction

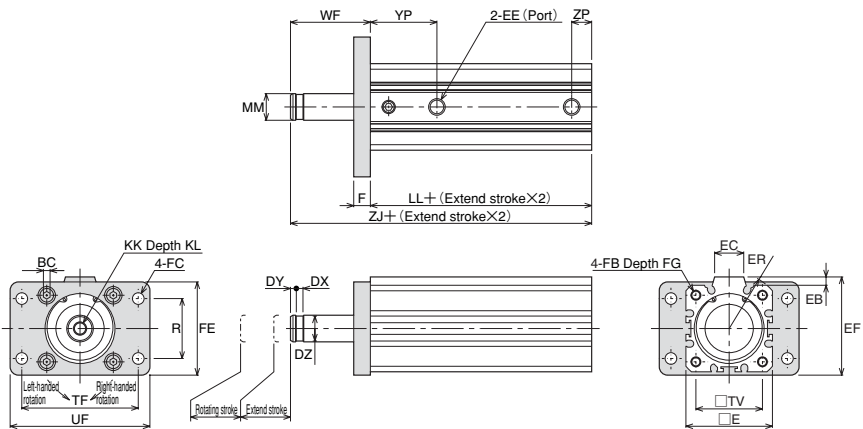

Note) For Rod end option K, please refer to the page for Rod end Square.

Dimensional Table / SD

Code Bore	DX	DY	DZ	E	EA	EB	EC	EE	ER	FB	FG	KK	KL
φ 40	4	3.5	φ 15	52	57	5	17.5	Rc1/8	R34.5	M6×1	12	M8×1.25	13
φ 50	4	12	φ 19	64	71	7	19	Rc1/4	R42.5	M8×1.25	16	M10×1.5	17
φ 63	4	12	φ 19	77	84	7	19	Rc1/4	R51	M10×1.5	20	M10×1.5	17

Code Bore	LL	MM	NN	TV	VF	WF	YP	ZJ	ZP
φ 40	113	φ 16	φ 29f9	40	5	28	40	141	12
φ 50	124	φ 20	φ 36f9	50	5	38	45	162	12
φ 63	127	φ 20	φ 40f9	60	5	38	45	165	13.5

Dimensional Table / FA

Code Bore	BC	DX	DY	DZ	E	EB	EC	EE	EF	ER	F	FB	FC	FE	FG
φ 40	4	4	3.5	φ 15	52	5	17.5	Rc1/8	59	R34.5	10	M6×1	φ 7	56	12
φ 50	5	4	12	φ 19	64	7	19	Rc1/4	74	R42.5	10	M8×1.25	φ 9	70	16
φ 63	6	4	12	φ 19	77	7	19	Rc1/4	87.5	R51	10	M10×1.5	φ 9	84	20

Code Bore	KK	KL	LL	MM	R	TF	TV	UF	WF	YP	ZJ	ZP
φ 40	M8×1.25	13	113	φ 16	36	70	40	84	48	40	161	12
φ 50	M10×1.5	17	124	φ 20	47	86	50	104	58	45	182	12
φ 63	M10×1.5	17	127	φ 20	56	98	60	116	58	45	185	13.5

RCA2/TRCA2 Bore CAD/DATA is available.



FB

RCA2 FB Bore Option Extend stroke Rotating direction

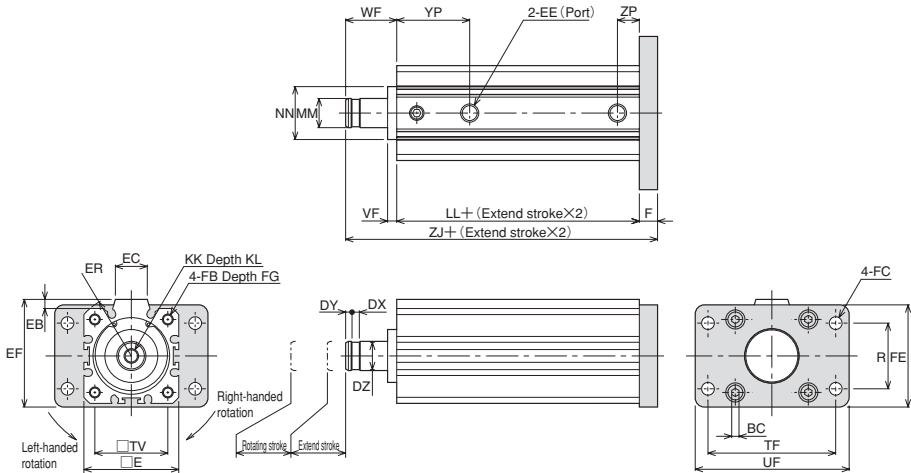

Note) For Rod end option K, please refer to the page for Rod end Square.

Dimensional Table / FB

Code Bore	BC	DX	DY	DZ	E	EB	EC	EE	EF	ER	F	FB	FC	FE	FG	KK	KL
φ 40	4	4	3.5	φ 15	52	5	17.5	Rc1/8	59	R34.5	10	M6×1	φ 7	56	12	M8×1.25	13
φ 50	5	4	12	φ 19	64	7	19	Rc1/4	74	R42.5	10	M8×1.25	φ 9	70	16	M10×1.5	17
φ 63	6	4	12	φ 19	77	7	19	Rc1/4	87.5	R51	10	M10×1.5	φ 9	84	20	M10×1.5	17

Code Bore	LL	MM	NN	R	TF	TV	UF	VF	WF	YP	ZJ	ZP
φ 40	113	φ 16	φ 29f9	36	70	40	84	5	28	40	151	12
φ 50	124	φ 20	φ 36f9	47	86	50	104	5	38	45	172	12
φ 63	127	φ 20	φ 40f9	56	98	60	116	5	38	45	175	13.5

Switch set

RCA2

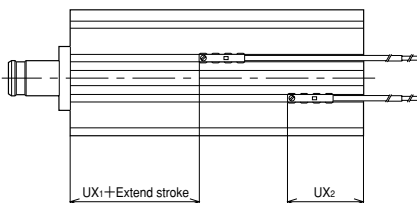

Dimensional Table

Bore (mm)	Contact		Noncontact	
	UX ₁	UX ₂	UX ₁	UX ₂
φ 40	58.5	34.5	62.5	30.5
φ 50	66.5	37.5	70.5	33.5
φ 63	66.5	40.5	70.5	36.5

Note) UX dimension is best mounting position when searching stroke end.

Operating range and hysteresis

Bore (mm)	Contact		Noncontact	
	Operating range	Hysteresis	Operating range	Hysteresis
φ 40	9~13	1.5 or less	2.5~5.5	1 or less
φ 50	10~14		3~7	
φ 63	11~15.5		3~7	

How to set switch detection position

- Screw the switch fixed screw until it touches nut.
(Please screw it counterclockwise, as shown in Fig.1, because it is left-handed screw.)
- Insert switch into switch mounting groove of cylinder body from head side or rod side and slide it.
- Fix it at best suited set position.
(When switch fixed screw is screwed clockwise, as shown in Fig.2, it is fixed on switch mounting groove of cylinder body.) Please set clamping torque around 0.1 to 0.2N · m.
- In case of the type with indicating lamp, light lights up when switch is on.

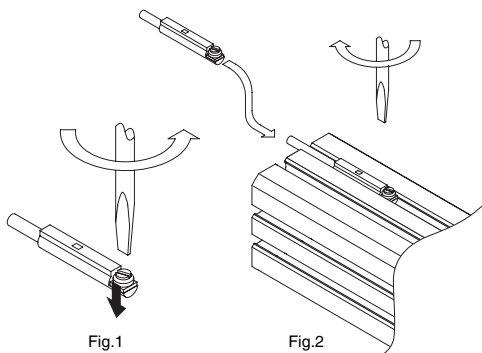

Rod End Square

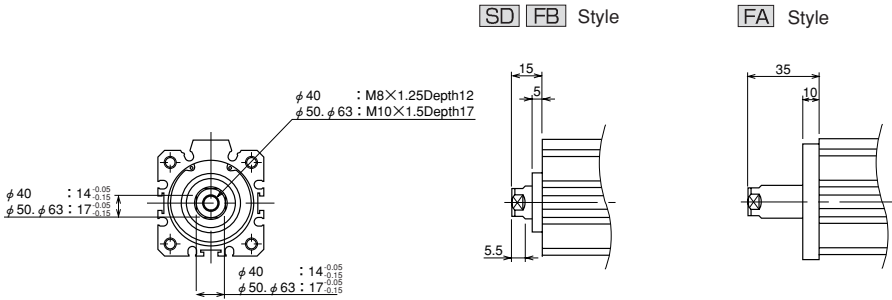

Arm section

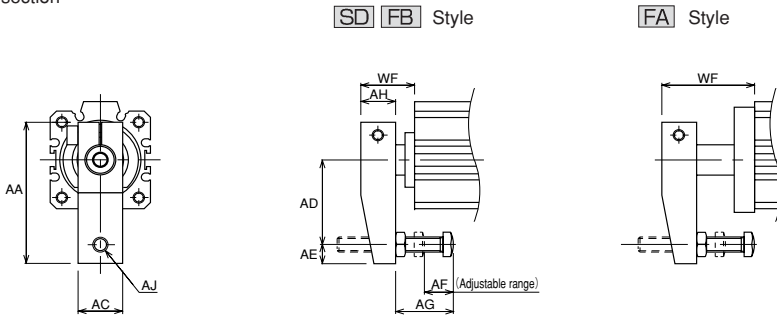

Dimensional Table

Code Bore	AA	AC	AD	AE	AF	AG	AH	AJ	WF	
									SD, FB	FA
$\phi 40$	75	23	45	10	15	30	18	M8×1.25	28	48
$\phi 50$	99	30	65	12	15	30	28	M10×1.25	38	58
$\phi 63$	99	30	65	12	15	30	28	M10×1.25	38	58

Handling Instructions

Precautions For Use

Movement & Mounting

- Sliding surface of piston rod shall not get scratched or dented. It may damage seals and cause air leakage.
- Body mounting surface and plate mounting surface on both sides shall not get scratched or dented, which may impair plain degree.
- When the body is mounted, piston rod shall not be twisted or bended as it will make working resistance high abnormally and bearing part will be abraded quickly, which may cause accuracy inferiority and air leakage.

Piping

- When piping, dust and foreign matter shall not be mixed in pipes. Pipe and fitting shall be fully flushed with fresh air before connected.
- Make sure to provide air filter on way of piping so that dust, moisture and foreign matter shall not be entered in pallet stopper.

Lubrication

- Although it is usable with non-lubrication, lubricant JIS K2213-1 (additive-free turbine oil ISO VG32) or equivalent shall be applied in case of lubrication.
Do not use machine oil and spindle oil.

Cleaning

- Please clean piston rod regularly when it gets heavily dirty.

Precautions For Arm Manufacturing And Mounting

Length of arm and moment of inertia shall be within range shown in the chart.

Please refer to next page for calculation for moment of inertia.

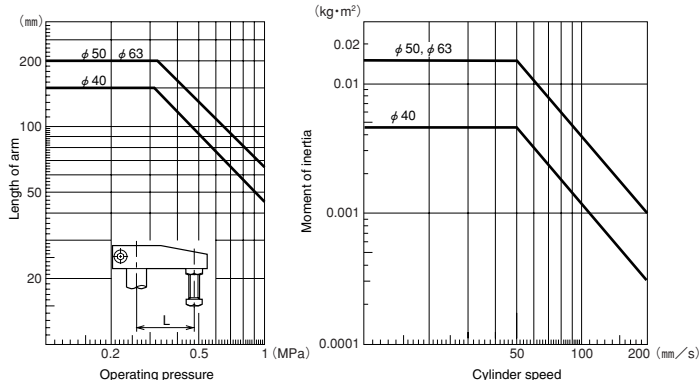

<Note> When mounting arm with female screw at both ends of piston rod, please use it under pressure shown in below table.

Bore	Pressure (MPa)
φ40	1
φ50	0.8
φ63	0.5

Arm Removal And Mounting Method

In order to remove arm from piston rod or mount it, bolt with hexagonal hole shall be tightened or loosened.

Standard mounting position is where arm upper face is as high as piston rod upper face.

Arm shall be removed or mounted when piston rod is pulled in.
Recommended clamping bolt: 4 to 5N · m

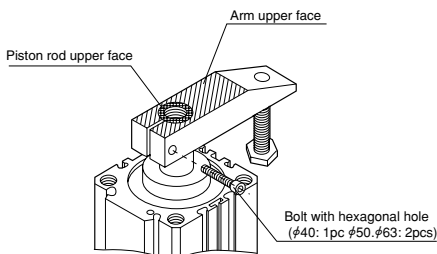

Moment Of Inertia Calculation Table

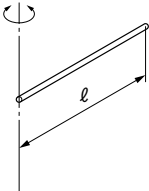
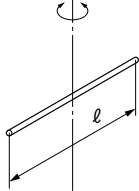
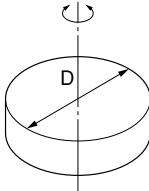
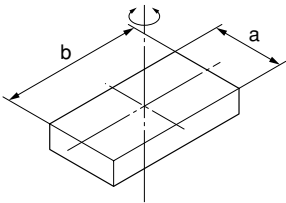
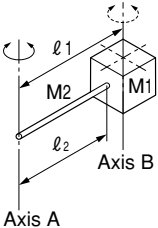
Outline	I : Moment of inertia	Outline	I : Moment of inertia
<ul style="list-style-type: none"> In case axis is at rod end 	$I = \frac{M \ell^2}{3}$	<ul style="list-style-type: none"> In case axis is at rod center  <p>Note) Axis runs through center of gravity</p>	$I = \frac{M \ell^2}{12}$
<ul style="list-style-type: none"> In case of cylindrical solid (incl. disc)  <p>Note) Axis runs through center of gravity</p>	$I = \frac{MD^2}{8}$	<ul style="list-style-type: none"> In case of rectangular solid  <p>Note) Axis runs through center of gravity</p>	$I = \frac{M}{12} (a^2 + b^2)$
<ul style="list-style-type: none"> In case of arm (rotated around on axis A)  <p>M1 : Attachment weight M2 : Arm weight l1 : Length from Axis A to center of gravity l2 : Arm length</p>	$I = I_1 + M_1 \ell_1^2 + \frac{M_2 \ell_2^2}{3}$ <p>I₁ : Inertia of attachment in case axis (axis B) running through center of gravity of attachment is centered.</p>	<p>I (I₁) : Moment of inertia kg · m² M (M₁, M₂) : Weight kg ℓ , a, b : Length m D : Diameter m</p>	