

Digital Flow Switch

Flow rate specifications	Low flow rate	Medium flow rate			High flow rate	
Type	Resin body	Resin body (Standard type)	Metal body	Stainless steel body	Metal body	Stainless steel body
Detection method	Magnetic proximity/ Iron proximity	Magnetic proximity/ Iron proximity	Magnetic proximity			
Machine type	DFS3-1002/5002	DFS3-1000/5000	DFS3-1200	DFS3-1500	DFS3-2000	DFS3-2500
Main unit material	Polyacetal (including glass)	Polyacetal (including glass)	BC6(Nickeling)	S C S 14	BC6(Nickeling)	S C S 14

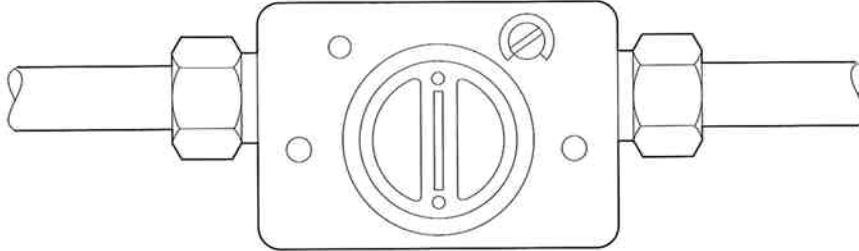

Digital Flow Switch + Digital Flow Meter

Combination in case interlock signal is to be issued when flow rate is insufficient, and reading flow rate

(DFS3-1002
 DFS3-5002
 DFS3-1000
 DFS3-2000
 DFS3-2500
 DFS3-1200
 DFS3-1500
 DFS3-5000) + (DFM2-1000)

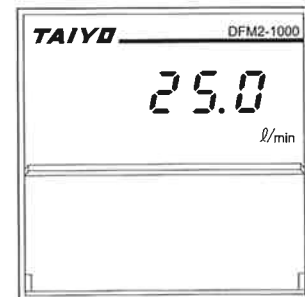
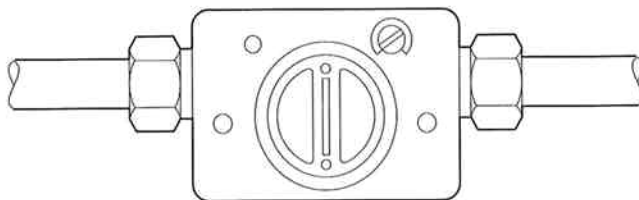

Notice) In case the digital flow switch is used as the sensor

Digital Flow Sensor + Digital Flow Meter

Combination in case only flow rate is read

DFT-1000

DFM2-1000

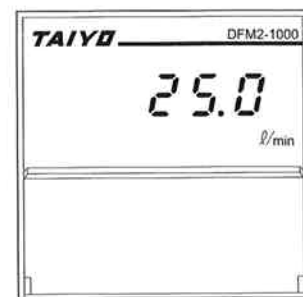
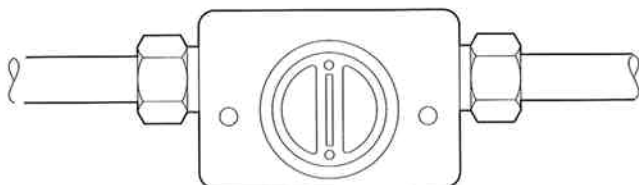

<Operation>

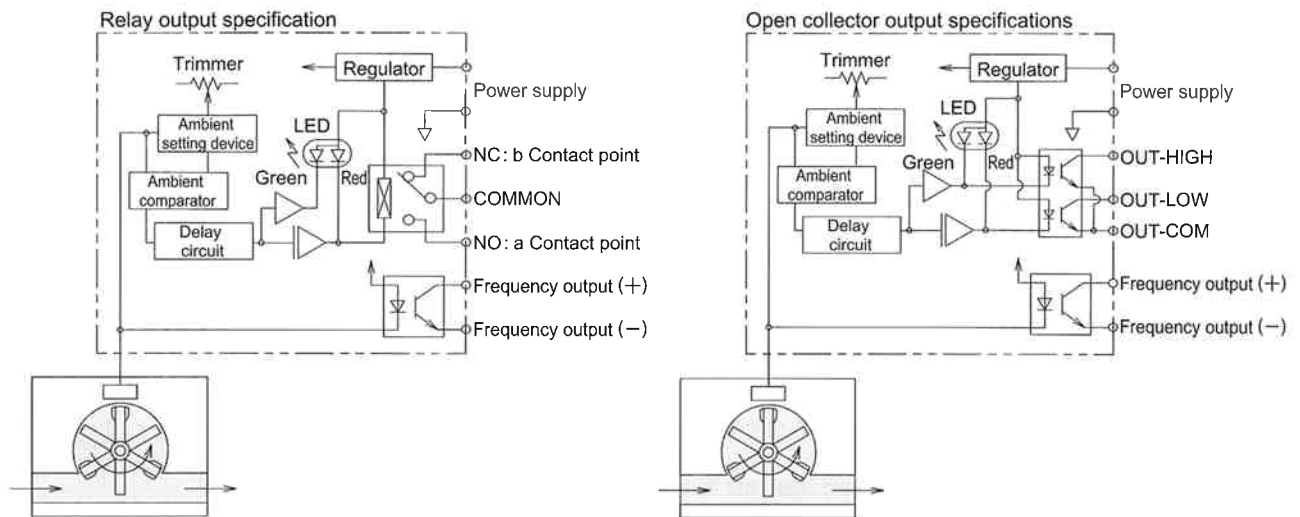

The rotor rotates (at the rotation number) in proportion to flow rate of fluid. Rotation of the rotor is sensed by the sensor on the body side, and is converted to electric pulse signal. Since this pulse signal adopts the digital type sensor, rectangular wave at constant wave height can be obtained structurally regardless of rotor rotation number, unlike in generating power by coil.

By comparing this pulse frequency with the frequency having been set by the trimmer, alarm is output and the output indication lamp (Red) lights up when the frequency exceeds the set value (or lowers the set value). Further, for preventing unnecessary alarm output by ripple of flow rate or instantaneous shut down, it is structured that alarm is output only when the frequency exceeds the set value in 500ms in the delay circuit shown by the figure.

Application Study

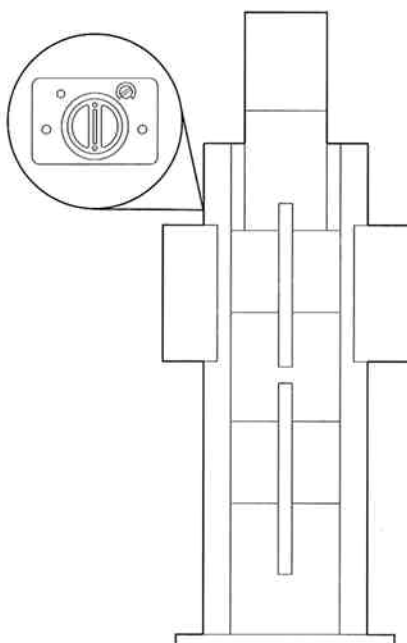

- Various vacuum systems including vacuum evaporator
- Semiconductor production system
- Spot welder (including chip drop detection)
- Laser processing machine
- Electron microscope
- X-ray
- Water treatment plant
- Nuclear power plant
- Others

Digital Flow Switch DFS3 Series

Precautions in using

- In using the flow switch, be sure to observe ambient temperature range and fluid temperature range. Using in exceeding the temperature ranges invites lowering magnetic power of the rotor magnet, output switching failure, shortening life time, etc.
- Be sure to use the flow switch in the flow rate range. Since flow rate is changed according to viscosity and temperature of the fluid, it is recommended to set the trimmer by actually making abnormal flow rate by the actual machine.
- If foams exist in the flow switch or in the fluid, rotation number of the rotor is raised than usual rotation number, and flow rate outputting alarm is changed. By standing the pipes of the flow switch on the downstream side and other means, make the flow switch inside being filled with water continuously. Flush the pipe inside beforehand, to remove dust and foreign matters.
- When rust, metal powder, dust and other abrasive materials are in the fluid, mount the filter on the upstream of the flow switch. Among others, when magnetic proximity type flow switch is used, iron powder, etc. in the fluid attach the magnet, liable to cause error operation.
- Check on power supply voltage, load voltage and electric specifications of the flow switch. Using incorrect voltage and current specifications may cause operation failure or breakage of the flow switch. Use the pipe adapter when the resin body type is used at the places affected by heat cycle and heat shock. Set the tightening torque to 5 ~ 10N.m, in case the pipe is directly fit to the resin body.

Precautions in wiring

- In working for wiring, be sure to turn off the power supply of the system of the electric circuit on the connection side, to prevent electric shock to the workers and breakage of the digital flow switch or load during working.
- Check on power supply voltage of the digital flow switch, load voltage and current specifications. Using incorrect voltage and current specifications may cause operation failure and breakage of the digital flow switch.
- Do not apply weight to the cable by bending, pulling, twisting, etc, to prevent disconnection of the cable.
- When the connection distance to the cable is long, fix the cable in the interval of about 20cm to prevent loosening of the cable. Loosening the cable may cause disconnection of the cable by pulling by feet, etc.
- When the cable is placed on the floor, protect the cable by metal pipes, etc. to prevent disconnection of the cable or short-circuit the cable, by treading directly and placing the cable under the system.
- Do not bind the cable together with high voltage wires of other electric machines, power supply cable and cables for power supply, or do not wire the cable nearby. Noise from high voltage wire, power supply cable and cables for power supply interferes the cable of the digital flow switch, causing error operation of the digital flow switch and load. It is recommended to protect the cable by shield pipes, etc. In AC100V specification, do not shield the power supply cable and signal cable together.
- Wires for earthing are used for protecting the digital flow switch from noise of the power supply line and overvoltage of power supply, etc. It is recommended to earth the earth wire in No.3 Class type.

Wiring method

Relay output specification

• DC

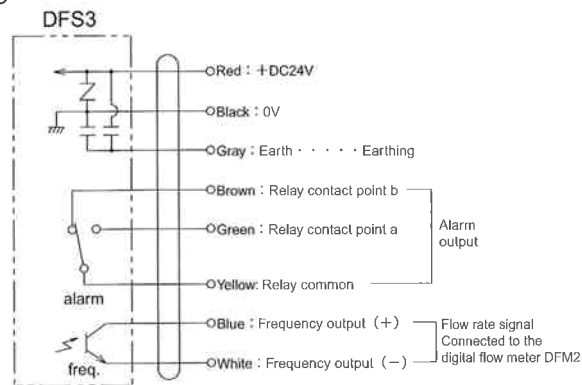

• AC

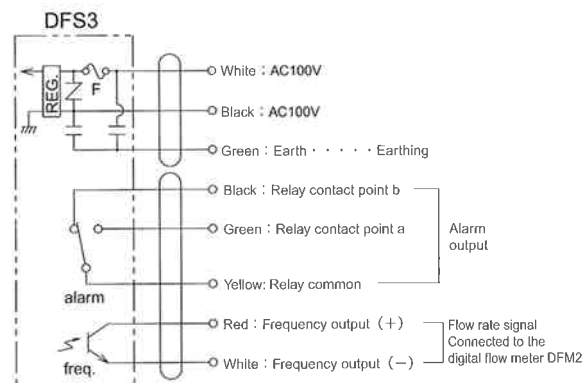

Open collector output specification

• DC

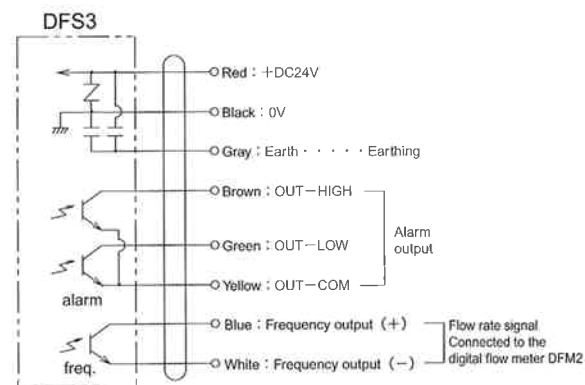

• AC

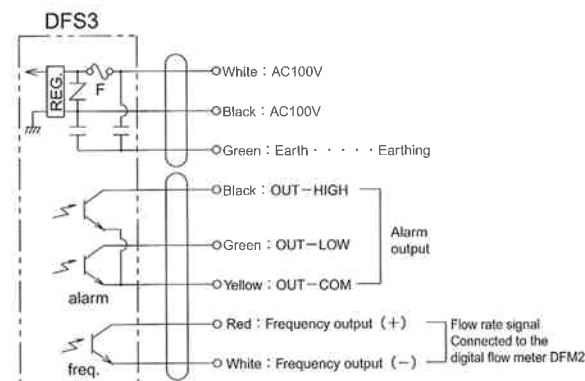

Relay output specification

Precautions in using the output relay

- In working wiring, be sure to turn off the power supply of the systems of the electric circuit on the connection side, to prevent electric shock to the workers or breakage of the digital flow switch and load.
- Be sure to connect load to the output contact point. Directly connecting the power supply without connecting load may cause fusion and burning of the contact points, etc.
- Do not let the alarm output relay output for long time (such as detecting abnormal increase of flow rate), to prevent raising temperature of the output relay coil and corrosion of the contact points. It is recommended to select the open collector output specification.
- Be sure to use the output contact points within the range of contact point capacity. Using by exceeding the Max. value of the contact point capacity may cause troubles such as abnormal wear of the contact points, shutdown, fusion, burning, etc.
When the output contact points are used for micro current circuit, continuity failure may be caused due to adsorption of oxide and carbide to the contact points. In using the output contact points for micro current circuit, it is recommended to select the open collector output specification.
- Never structure the circuit making overcurrent or causing burning, in case 3 output contact points of NC, NO and COM are short-circuited.

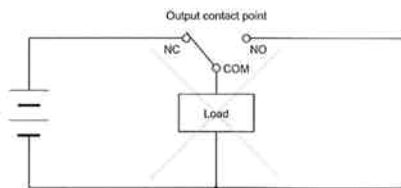

- If the digital flow switch is used in the atmosphere with high humidity and load liable to cause arc is connected to the output contact point, metal in the output relay may be corroded, disturbing operation. Use at ambient humidity 85%RH or under (ambient temperature 20°C).
- Do not switch high load and low load at one output relay, to prevent disturbing operation by attaching the contact point flying matters generated in switching high load to the switching contact point of low load.

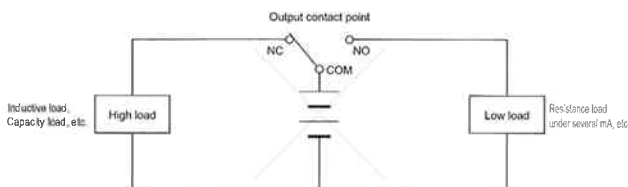

- In case of driving semiconductor at the output contact point, response may be made to the bouncing and chattering of the contact point. Under such conditions, it is recommended to select open collector output specification.
- In using the A contact point of the output relay, the contact point is closed when actual flow rate is lowered than the set flow rate.
- The output relay is driven when actual flow rate is lowered than the set flow rate. Therefore, if power supply is turned off due to any reason, the output contact point is put in the state exceeding the set flow rate. Take special notice to this point, in designing the system.

Precautions in protecting contact points

- In case of connecting inductive load such as DC relay by using the output contact points, be sure to perform surge absorption by diode, etc. When the inductive load circuit is opened, reverse voltage of several hundreds to several thousands V is generated and discharging occurs at the contact points. By this discharge, organic matters in the air are decomposed, generating oxide and carbide to the contact points and inviting connection failure, and further, causing drifting of the contact points and locking the contact points.

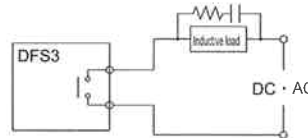

Standard capacitor value:
0.5 ~ 1(μF) to current 1mA
Standard resistance:
0.5 ~ 1(Ω) to contact point current 1V

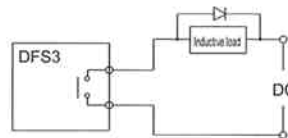

Use diode whose peak inverse voltage is 10 times or more of the circuit voltage and forward current is above the load current.

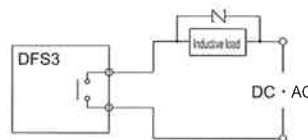

Select the cut voltage Vd satisfying the below conditions. In AC current, multiplying by √2 is required.
Max. voltage at the contact point > Vc > Power supply voltage x 1.5

- In fitting protective elements, it is necessary to fit just near the load or the contact point. If not, effect of the protective element may be lowered. Fit within 50cm as standard.
- In case the lead wire connecting the output contact point and load exceeds 10m or the lead wire is connected to the AC input type PLC (programmable controller) and capacitive load (capacitor, etc.), rush current is generated by output ON. Be sure to provide the protective circuit, as shown in the figure.

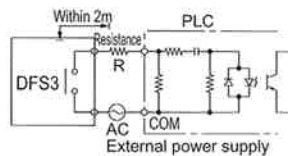

R: Rush current clamping resistance
R= Use resistance as high as possible within the range allowed by the load side circuit.

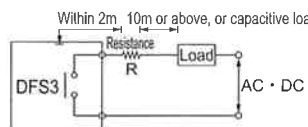

Note) Excessively high resistance may not operate load. Wire as near as the switch possible. (within 2m)

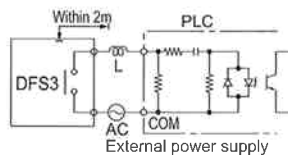

L : Choke coil
L=Equivalent to about 2mH
Note) Wire as near as the switch possible. (within 2m)

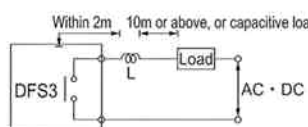

- If protection circuit is not provided as in the above figure, the inside electric circuit of the digital flow switch may be broken by rush current.

Open collector output specification

Precautions in using open collector output

- In working for wiring, be sure to turn off the power supply of the system of the electric circuit on the connection side, to prevent electric shock of the workers or breakage of the digital flow switch and load during working.
- Do not use by exceeding the use voltage range (Max. allowable voltage DC50V). If voltage above the use voltage range is applied or AC power supply is applied, internal elements may be broken or burned.

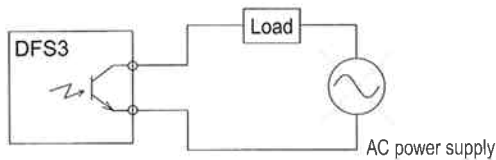

- Do not short-circuit load, to prevent breakage or burning of the internal elements.

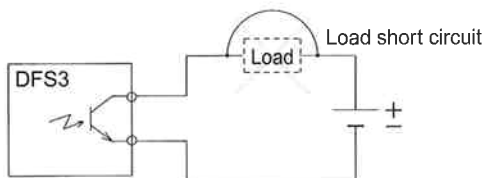

- Do not confuse polarities of power supply in wiring, to prevent breakage or burning of the internal elements.

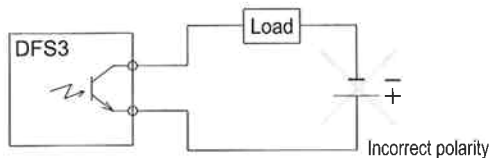

- Be sure to wire by applying load. If not, the internal elements may be broken or burned.

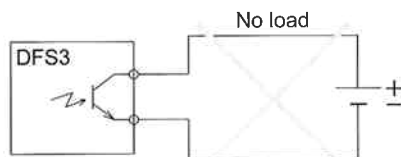

Connection with PLC (programmable controller)

- In case power supply is integrated in the PLC

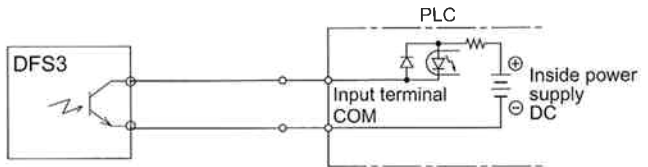

Note) As for details, confirm with the PLC Instruction Manual.

- In case power supply is not integrated in the PLC

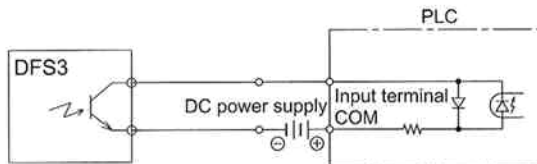

Note) As for details, confirm with the PLC Instruction Manual.

- In case outputs of several digital flow switches are connected in parallel to the load (in case of inputting to PLC in the OR circuit, etc.), take care of output leak current of the digital flow switch. Load may operate by the leak current.

Leak current per one output $I_{CEO} \leq 0.1\text{mA}$
($V_{CEO}=80\text{V}$ $T_a=25^\circ\text{C}$)

- In case output of several digital flow switches are connected in series to the load (in case of inputting to PLC in the AND circuit, etc.), take care of output residual voltage of the digital flow switch. Load may not operate due to output residual voltage.

Output residual voltage per one output $V_{CEO} \leq 0.8\text{V}$
($I_c=10\text{mA}$ $T_a=25^\circ\text{C}$)

Precautions in protecting output circuit

- In connecting inductive load of the DC relay, etc., be sure to absorb surge due to diode, etc. By reverse voltage generated to load in output OFF, the output elements of the digital flow switch may be broken.

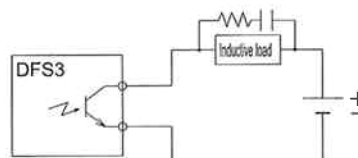

Resistance value is around load resistance. Capacitor value is determined through experiment.

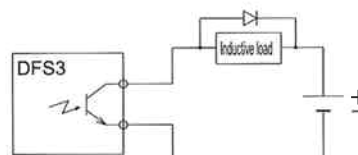

Select diode whose peak inverse voltage is around 5 ~ 10 times of the circuit voltage and whose forward current is above circuit current.

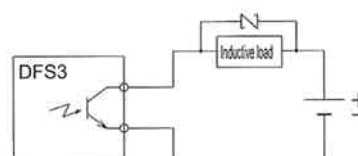

Varistor's cut voltage V_C is selected by the below condition.
Power supply voltage $< V_C < 80\text{V}$

Plug mounting method

- Select necessary flow rate range from the flow rate range A and B, screw the attached plug into the unnecessary range port.
Notice) In DFS3-2000 2500, selecting flow rate range is not necessary.

DFS3-1000
DFS3-5000

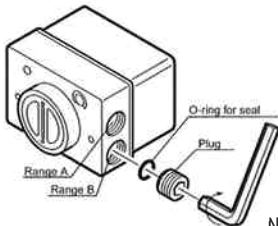

- Ex.)
- In case of the set flow rate 1 l/min (Constant time flow rate 2 l/min) and primary side pressure 0.2MPa, select the range A, and plug the range B.
 - In case of the set flow rate 3 l/min (constant time flow rate 6 l/min) and primary side pressure 0.1MPa, select the range B, and plug the range A.

Note) • In fitting DFS3-1000,5000 plug, use the attached O-ring for seal. Since the plug is of resin, tighten at 3 ~4N · m torque.

• In fitting DFS3-1200,1500 plug, be sure to use the seal tape.

Notice) Do not use plugs other than the attached ones.

DFS3-1200
DFS3-1500

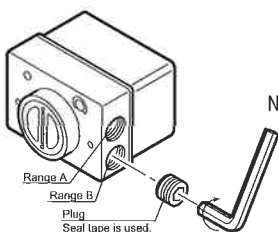

Pipe adapter mounting method

Mounting the pipe adapter set (DF-AP)

Surely screw the pipe adapter to firmly contact the body side and the adapter working face.

Tightening torque: 15 ~20N · m
(DFS3-1000,5000)

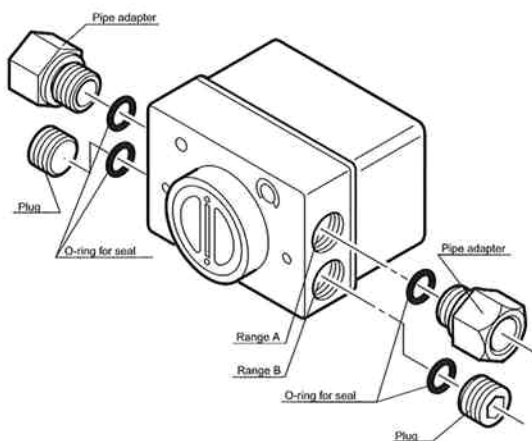

Note) • The figure is the mounting figure in using the A range.
The adapter for piping can be fit to both A and B.
• Fit the plug according to the plug fitting method.

- In piping, perform flushing before connecting, never to include cuts of the seal tape, dust, rust, etc.

Note) In piping to the pipe adapter, be sure to use the seal tape, and tighten at screwing torque 15 ~20N · m. (Wind the seal tape by 2 round winding or under.)

Mounting the low flow rate pipe adapter set (DF-FW2)

- For piping in low flow rate type, insert the attached nozzle into the range A flowing direction N side, then, insert the O-ring for seal and screw the low flow rate pipe adapter.

Tightening torque: 15 ~20 N · m

- Fit the pipe adapter attached to the low flow rate type to the range A flowing direction OUT side together with the O-ring for seal, only when necessary.

Tightening torque: 15 ~ 20N · m

Note) The adapter cutting V channel on the hexagon side is the low flow rate pipe adapter. If the pipe adapter is mounted instead of the low flow rate pipe adapter, leak of liquid and breakage of the port may be caused, requiring special notice in mounting.

<DFS3-1002 · 5002>

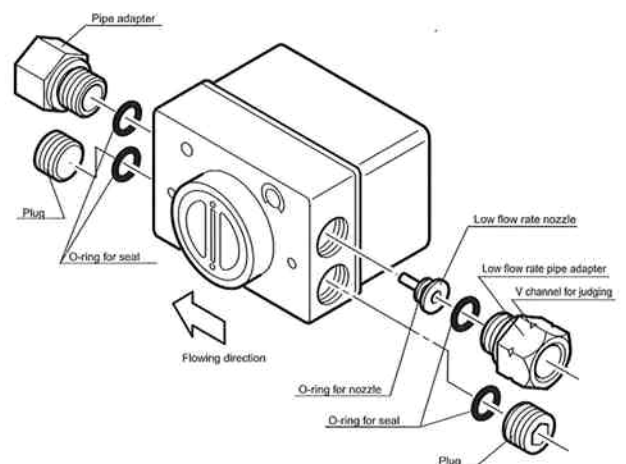

Note) • The figure is the mounting figure in case of flowing water in the arrow direction.
• Fit the plug according to the plug fitting method.

Note) • Firmly insert the low flow rate nozzle, to screw the low flow rate pipe adapter to the deepest.
• Firmly screw the adapter to tightly connect the body side and the adapter working face.

- In piping, perform flushing before connecting, never to include cuts of the seal tape, dust, rust, etc. in the pipe.

Note) In piping to the low flow rate pipe adapter and the pipe adapter, be sure to use the seal tape, and tighten at the screwing torque 15 ~ 20 N · m.

(Wind the seal tape by 2 round winding or under.)

Tightening Torque Table

Unit: N · m

Tightening part	Tightening torque range
Direct piping to the resin body	5~10 Note 1)
Fitting the resin plug	3~4
Fitting the pipe adapter	15~20
Fitting the low flow rate pipe adapter	
Piping to the pipe adapter	1.2~1.8
Fitting the resin body M5×0.8	

Note 1) In the resin body type, it is recommended to use the pipe adapter. (Wind the seal tape by 2 round winding or under.)

Main unit mounting method

Mounting direction of the main unit is freely determined. Take the below notices in mounting.

- (1) In case of suspending the digital flow switch by steel pipes

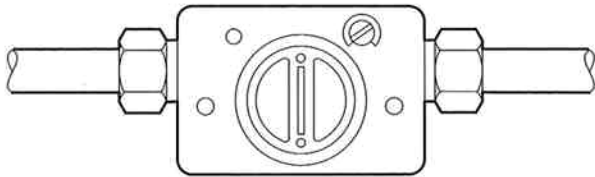

Note) In the resin body DFS3-100※, 500※, it is recommended to fit the pipe adapter DF-AP (relating parts), to prevent breakage of the port.

- (2) In case one side is screwed into the steel pipe and other side is piped with the resin tube.

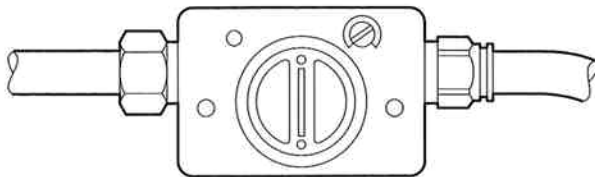

Note) In the resin body DFS3-100※, 500※, it is recommended to fit the pipe adapter DF-AP (relating parts), to prevent breakage of the port.

- (3) In case of fixing the main unit to the plate and piping with the resin tube

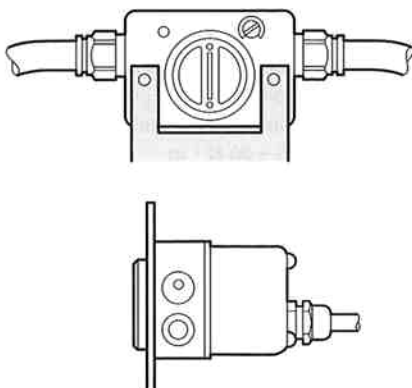

Note) Tighten the fitting screw part at 1.2 ~ 1.8N · m torque.
(DFS3-100※, 500※)

Disassembling method

- Never remove the cover. (When the cover was removed by users and operation became abnormal, warranty is not applied.)
- By inserting the attached rotor cap opener into the channel of the rotor cap and rotating left, the rotor cap, rotor and rotor pin can be disassembled easily.
- Excluding DFS3-1500, 2500, in re-assembling, apply grease thinly to the rotor cap O-ring part. As grease, silicone grease or Teflon grease are recommendable.
In applying grease to DFS3-1500, 2500, use the one suitable to the fluid.
- When iron powder is attached to the rotor magnet part in disassembling, the sensor may not detect magnet. It is recommended to select the iron proximity detection type.

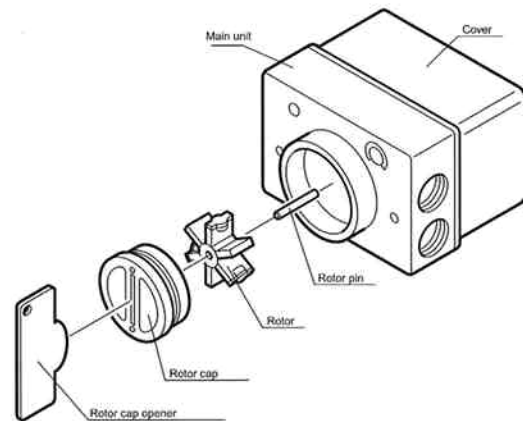

Note) Place the rotor cap opener near the flow switch by holding with a string, to be used any time.

Parts Table at liquid touching part

Name	Rotor cap		Rotor			Rotor pin
	Polyether sulfon	SUS316	Polyacetal	ETFE	Polyacetal	Alumina ceramic
Type	DF-RCP	DF-RCS	DF-RP	DF-RF	DF-RS	DF-PS
DFS3-1000	●	—	●	—	—	●
DFS3-1002	●	—	●	—	—	●
DFS3-1200	●	—	●	—	—	●
DFS3-1500	—	●	—	●	—	●
DFS3-2000	●	—	●	—	—	●
DFS3-2500	—	●	—	●	—	●
DFS3-5000	●	—	—	—	●	●
DFS3-5002	●	—	—	—	●	●

Digital Flow Sensor DFT Series

Wiring method

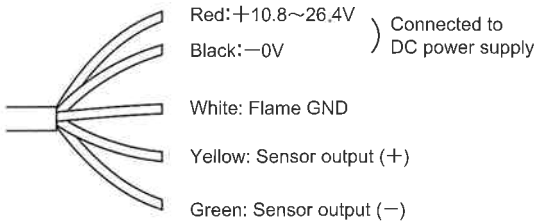

Wiring method with Digital Flow Meter

(Digital Flow Sensor DFT1000) (Digital Flow Meter DFM2-1000)

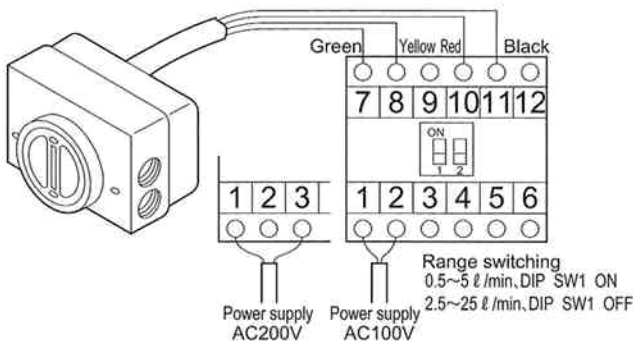

As for wiring method, refer to the Digital Flow Meter Instruction Manual.

Wiring method with devices other than Digital Flow Meter

Connection with PLC (programmable controller)

- In case power supply is integrated in the PLC

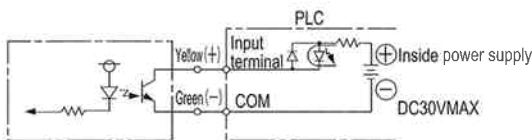

Note) As for details, refer to the PLC Instruction Manual.

- In case power supply is not integrated in the PLC

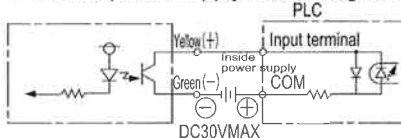

Note) As for details, refer to the PLC Instruction Manual.

Precautions in wiring

- In working for wiring, be sure to turn off the power supply of the system of the electric circuit on the connection side, to prevent electric shock to the workers and breakage of the digital flow sensor during working.

- Do not apply weight to the cable by bending, pulling, twisting, etc, to prevent disconnection of the cable.
- When the connection distance to the cable is long, fix the cable in the interval of about 20cm to prevent loosening of the cable. Loosening the cable may cause disconnection of the cable by pulling by feet, etc.
- When the cable is placed on the floor, protect the cable by metal pipes, etc. to prevent disconnection of the cable or short-circuit the cable, by treading directly and placing the cable under the system.
- Do not bind the cable together with high voltage wires of other electric machines, power supply cable and cables for power supply, or do not wire the cable nearby.
Noise from high voltage wire, power supply cable and cables for power supply interferes the cable of the digital flow sensor, causing error operation of the digital flow sensor and load. It is recommended to protect the cable by shield pipes, etc.

Piping method

- Select necessary flow rate range from the flow rate range A and B, screw the attached plug into the unnecessary range port.

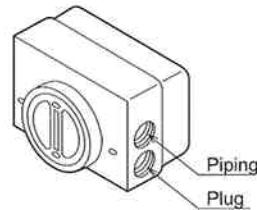

Ex.) • In case of the set flow rate 1 ℓ /min (Constant time flow rate 2 ℓ /min) and primary side pressure 0.2MPa, select the range A, and plug the range B.

Ex.) • In case of the set flow rate 3 ℓ /min (Constant time flow rate 6 ℓ /min) and primary side pressure 0.1MPa, select the range B, and plug the range A.

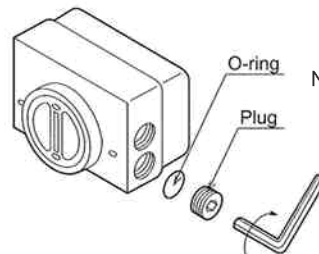

Note) In fitting the plug, use the attached O-ring for seal. Since the plug is of resin, tighten at 3~4N · m torque.

- In piping, perform flushing before connecting, never to include cuts of the seal tape, dust, rust, etc.

Tightening Torque Table

Unit: N · m

Tightening part	Tightening torque range
Direct piping to the resin body	5~10 Note 1)
Fitting the resin plug	3~4
Fitting the pipe adapter	15~20
Fitting the low flow rate pipe adapter	
Piping to the pipe adapter	1.2~1.8
Fitting the resin body M5×0.8	

Note 1) In the resin body type, it is recommended to use the pipe adapter. (Wind the seal tape by 2 round winding or under.)

Mounting method

- ① In case the Flow Sensor is suspended with steel pipe



- (Notice) In case the steel pipe is excessively long, moment is applied to the Flow Sensor main unit, liable to break the port. Fitting the adapter DF-AP (relating parts) for piping is recommendable.

- ② In case one side is screwed into the steel pipe and the other side is piped with the resin tube



- (Notice) In case the steel pipe is excessively long, moment is applied to the Flow Sensor main unit, liable to break the port. Fitting the adapter DF-AP (relating parts) for piping is recommendable.

- ③ In case the main unit is fixed to the plate, and is piped with the resin tube

1)

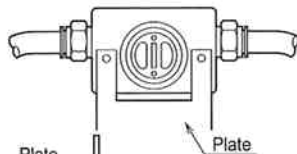

2)

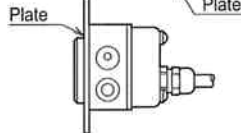

- (Notice) Tighten the fitting screw part with 1.2 ~ 1.8N · m torque.

Disassembling method

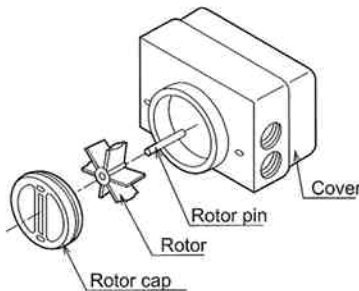

- Never remove the cover. (When the cover was removed by users and operation became abnormal, warranty is not applied.)
- By inserting the attached rotor cap opener into the channel of the rotor cap and rotating left, the rotor cap, rotor and rotor pin can be disassembled easily.

- In re-assembling, apply grease thinly to the rotor cap O-ring part. As grease, silicone grease or Teflon grease are recommendable.

Precautions in use

- In using the flow sensor, be sure to observe ambient temperature range and fluid temperature range. Using in exceeding the temperature ranges invites lowering magnetic power of the rotor magnet, output switching failure, shortening life time, etc.
- Be sure to use the flow sensor within the use flow rate range.
- If foams exist in the flow sensor or in the fluid, rotation number of the rotor is raised than usual rotation number. By standing the pipes of the flow sensor on the downstream side and other means, make the flow sensor inside being filled with water continuously.
- Flush the pipe inside beforehand, to remove dust and foreign matters.
- When rust, metal powder, dust and other abrasive materials are in the fluid, mount the filter on the upstream of the flow sensor. Iron powder, etc. in the fluid attaches the magnet of the rotor, liable to cause error operation.
- Use the pipe adapter when the resin body type is used at the places affected by heat cycle and heat shock. Set the tightening torque to 5 ~ 10N · m, in case the pipe is directly fit to the resin body.

Tightening Torque Table

Unit: N · m

Tightening part	Tightening torque range
Direct piping to the resin body	5~10 Note 1)
Fitting the resin plug	3~4
Fitting the pipe adapter	15~20
Fitting the low flow rate pipe adapter	
Piping to the pipe adapter	1.2~1.8
Fitting the resin body M5×0.8	

Note 1) In the resin body type, it is recommended to use the pipe adapter. (Wind the seal tape by 2 round winding or under.)

Digital Flow Meter DFM2 Series

- Before using the flow meter actually, carefully read the Instruction Manual attached to the commodity and instruction manuals of the devices (DFS3, DFT) used together with this flow meter.
- As for calibration method of meter indication values, refer to the Instruction Manual attached to the commodity.

Installation place

- Be sure to use the flow meter outdoors.
- Do not use at the places generating organic solvents (methyl alcohol, thinner, benzine, etc.), affected by chemicals such as high alkali, high acidic substances, splashed by water and oil, contaminated with much dusts or affected by vibration and shock.
- In case of using in the environment generating much static electricity, put the flow meter main unit apart from the source generating static electricity as long as possible, to prevent error operation.
- Use panel with high stiffness, by taking consideration of self-weight of the flow meter main unit and self-weight of the cable.
- For fitting, use the attached fitting metals. Fix the main unit flange part and the panel by tightly keeping with the fitting metals. (Tightening torque of the fitting metal screws is at about $0.5\text{N} \cdot \text{m}$.)
- For outside dimensions and panel cut size in fitting the panel, refer to "Outline drawing".

- When the cable is placed on the floor, protect the cable by metal pipes, etc. to prevent disconnection of the cable or short-circuit the cable, by treading directly and placing the cable under the system.
- Do not bind the cable together with high voltage wires of other electric machines, power supply cable and cables for power supply, or do not wire the cable nearby. Noise from high voltage wire, power supply cable and cables for power supply interferes the cable of the digital flow meter, causing error operation of the digital flow meter.

It is recommended to protect the cable by shield pipes, etc. (Do not shield the power supply cable for the flow meter and signal cable together.)

Precautions in wiring

- Correctly wire the cables according to the Connection Drawing.
- For connecting terminals, using crimp-style terminals recommended. Use the crimp-style terminals shown in the below figure.

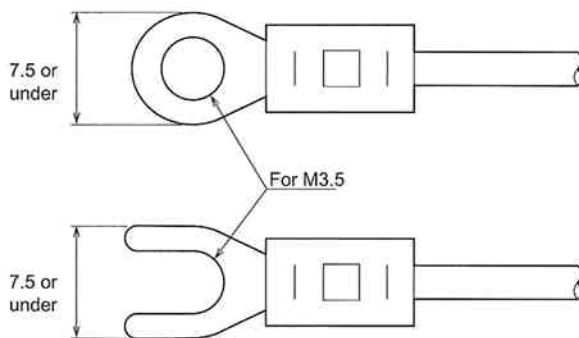

- In working for wiring, be sure to turn off the power supply of the system of the electric circuit on the connection side, to prevent electric shock to the workers and breakage of other electric devices and the digital flow meter during working.
- Do not apply weight to the cable by bending, pulling, twisting, etc, to prevent disconnection of the cable. As for Min. bending radius, etc., please contact the cable manufacturer.
- When the connection distance to the cable is long, fix the cable in the interval of about 20cm to prevent loosening of the cable. Loosening the cable may cause disconnection of the cable by pulling by feet, etc.