



Compact Design Hydraulic Cylinder 160S-1

16MPa Compact Design Hydraulic Cylinder with Steel Body

- Operates up to 10 million times at maximum 16 MPa.
- Abrasion resistant seal is standard.
Standard type cylinders are fully operable at ambient temperatures of up to 120°C.
- Introducing special copper alloy for vital hydraulic cylinder.
- Sliding type switches allow flexible switch placement.



Standard Specifications

Types	Specifications of General Purpose	Cutting Fluid Proof Types
Nominal pressure	16 MPa	
Maximum operating pressure	16 MPa	
Proof test pressure	24MPa	
Minimum working pressure	0.3 MPa	
Operating speed range	8 - 100 mm/s	
Temperature range (Ambient temperature and oil temperature)	Standard type	-10 - +120°C
	Switch set AX · AZ type	-10 - +70°C (Note)
	WR · WS type	-10 - +60°C (free of freeze)
Structure of cushioning	None	
Adaptable working oil	Petroleum-based fluid (For other working oil, refer to the table of working oil adaptability)	
Tolerance of thread	JIS 6 g/6H (JIS grade 2 or equivalence)	
Tolerance of stroke	0 to 0.8mm	
Mounting type	SD, ST, LA, LD, FA, FB	SD, LD, FA, FB
Rod end threads	Female and male threads	
Suitable switches for switch set	160S-1R: AX · AZ types WR · WS types	160SW-1R: WR · WS types

Note) The switch 'AX125' and 'AZ125' are newly developed for high temperature circumstance up to 100°C.

Cutting fluid proof models

- These models can be used in environments where the machine tool cutting oil (coolant) can be splashed.
- Sealing materials suitable for each cutting oil are as shown in the right side table:

Terminologies (Referred to the revised JIS B8367)

Nominal pressure

Pressure to be used to express a cylinder model's typical performance. This pressure value does not always match the actual operating pressure (rated pressure) at which the cylinder's performance is ensured under the specified conditions.

Maximum operating pressure

The cylinder's maximum internal pressure available. This pressure differs from the relief valve's set pressure. Pressures that are higher than the relief valve's set pressure, such as surge pressure during valve changing, are applied to the inside of the cylinder.

Proof test pressure

Proof test pressure is defined what could keep performance of cylinder through test pressure and nominal pressure.

Minimum working pressure

The minimum pressure that the cylinder placed horizontally without a load can work.

Notes) • This cylinder is not equipped with an air bleeder.

- Since lateral load (eccentric load) cannot be applied to the piston rod, carefully adjust it after rod end attachment.

- The working temperature range depends on the material of packings. For details, refer to the selection materials in the beginning of this catalogue.

- If the piston touches the cylinder end at the stroke end, decelerate the cylinder to a speed lower than the minimum operating speed.

Allowable Seal Material (Hydrogenated Nitrile Rubber) and Cutting Oil

Non-water Soluble Cutting Oil		Water Soluble Cutting Oil
Type 1	Type 2	
○	×	○

○: All wable ×: Unallowable

Lines

Unit: mm

Structure	Type	Mounting Type	ø20	ø25	ø32	ø40	ø50	ø63	ø80	ø100	ø125
General purpose type	Double Acting Single Rod	Standard type 160S-1	SD (ST)	●	●	●	●	●	●	●	●
			LA			●	●	●	●		
			LD, FA, FB	●	●	●	●	●	●	●	
		Switch set 160S-1R	SD (ST)			●	●	●	●	●	
			LA			●	●	●	●		
			LD, FA, FB			●	●	●	●	●	●
	Double Acting Double Rod	Standard type 160S-1D	SD	●	●	●	●	●	●	●	●
			LA			●	●	●	●		
			LD, FA	●	●	●	●	●	●	●	●
		Switch set 160S-1RD	SD			●	●	●	●	●	
			LD, FA			●	●	●	●	●	●
						●	●	●	●	●	●
Cutting fluid proof type	Double Acting Single Rod	Standard type 160SW-1	SD			●	●	●	●	●	
			LD, FA, FB			●	●	●	●	●	●
		Switch set 160SW-1R	SD			●	●	●	●	●	
			LD, FA, FB			●	●	●	●	●	●
	Double Acting Double Rod	Standard type 160SW-1D	SD			●	●	●	●	●	
			LD, FA			●	●	●	●	●	●
		Switch set 160SW-1RD	SD			●	●	●	●	●	
			LD, FA			●	●	●	●	●	●

Compact Design Hydraulic Cylinder

- Notes) ● Switches can't be mounted on Standard type. You are requested to select "Switch set" type when you would like to use switches.
 ● The ST mounting type is a made-to-order product.

Standard type

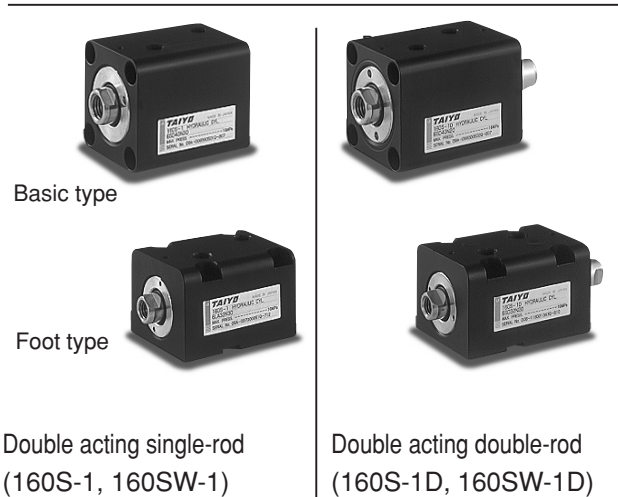

Switch set

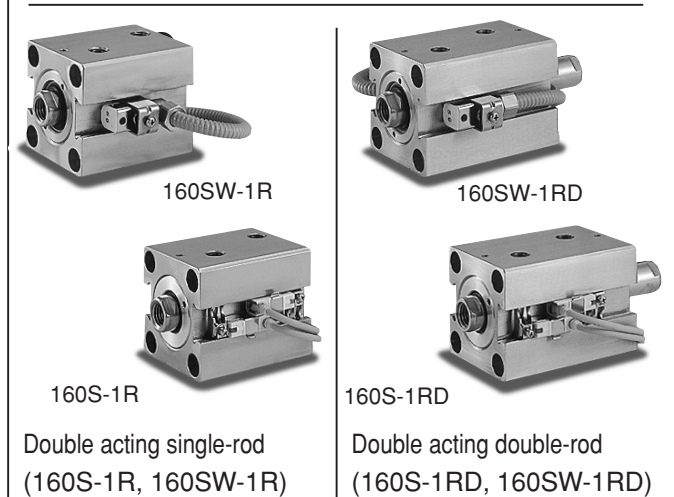

- Cylinder dimensions are all the same for both general purpose and cutting fluid proof types.

General purpose type

Dotted lines for types and symbols are not written when unnecessary. ■ Semi-standard components

● Standard type: 160S-1

● Switch set: 160S-1R

Series ①: 6

Packing material ②: SD

Mounting type ③: 40

Cylinder bore ④: N

Cushion type ⑤: 50

Stroke ⑥: T

Thread type ⑦: G

Port specification ⑧: AF

Switch symbol ⑨: 2

Switch quantity ⑩: -

Lock nut ⑪: L

Air vent ⑫: -

Standard type

160S-1 : Double acting single-rod
160S-1D : Double acting double-rod

Switch set

160S-1R : Double acting single-rod
160S-1RD : Double acting double-rod

⑥ Hydrogenated nitrile rubber (standard)
③ Fluoric rubber (semi-standard)

Note) The seal of bore size 20mm & 25mm is only Nitrile rubber for high temperature.

SD SD type, basic type
ST Thread holes mounting
LA LA type, foot type
LD Foot type
FA Head flange mounting
FB Cap flange mounting

Note) LD,FA mounting style cylinders consist of SD cylinder and each bracket. In this case, SD cylinder's

Standard type	
SD	: ø20 - ø125
ST	: ø32 - ø80
LD, FA, FB	: ø20 - ø80
LA	: ø32 - ø63
Switch set	
SD, ST, LD, FA, FB	: ø32 - ø80
LA	: ø32 - ø63

None Rc thread
G G thread

Note) G screw is only for SD Mounting.

- Female thread (no symbol for the standard type)
T Male thread

Note) Double-rod and male thread means both sides are male thread as standard.

with one lock nut
Note) Available only for male thread type
Additional order is required when 2 or more lock nuts are necessary.

Switch quantity (1 or 2)

Switch symbol
Note) Select applicable switches out of the Switch List.

❗ Notes on order for switch sets

- If a switch is unnecessary, enter the switch symbol ⑨ and the switch quantity ⑩ of 0.
- When ordering a switch set, switches are not mounted to cylinders at delivery.

None R thread
G G thread

Note) G screw is only for SD Mounting.

- Female thread (no symbol for the standard type)
T Male thread

Note) Double-rod and male thread means both sides are male thread as standard.

Cylinder stroke (mm)

Without cushion

Cutting fluid proof type

● Standard type: 160SW-1

● Switch set: 160SW-1R

Series ①: 6

Packing material ②: SD

Mounting type ③: 40

Cylinder bore ④: N

Cushion type ⑤: 50

Stroke ⑥: T

Thread type ⑦: G

Port specification ⑧: 5

Switch symbol ⑨: 2

Switch quantity ⑩: -

Lock nut ⑪: L

Air vent ⑫: -

Standard type

160SW-1 : Double acting single-rod
160SW-1D : Double acting double-rod

Switch set

160SW-1R : Double-acting single rod
160SW-1RD : Double-acting double rod

Note) For explanations for models other than the above, refer to the general purpose type models.
ST, LA is not available.

Hydrogenated nitrile rubber

Cylinder bore (mm)
ø32 - ø100
Note) 100mm bore is not available for LD, FA, FB.

5	WR525 (cord extended from the rear, with 5 m cord)
8	WR535 (cord extended from the top, with 5 m cord)
5F	WR525F (cord extended from the rear, with 5 m cord/flex tube attached)
8F	WR535F (cord extended from the top, with 5 m cord/flex tube attached)
RA	AX205W (cord extended from the rear, with 5 m cord)
RB	AZ205W (cord extended from the top, with 5 m cord)
2	WS235 (cord extended from the rear, with 5 m cord)
1	WS245 (cord extended from the top, with 5 m cord)
2F	WS235F (cord extended from the rear, with 5 m cord/flex tube attached)
1F	WS245F (cord extended from the top, with 5 m cord/flex tube attached)

Switch List

Kind	Switch Symbol	Load Voltage Range	Load Current Range	Maximum Open/Close Capacity	Protective Circuit	Indicating Lamp	Wiring Method	Cord Length	Applicable Load Device	
Contact	AF AX101	DC:5 - 30 V AC:5 - 120 V	DC:5 - 40mA AC:5 - 20mA	DC:1.5W AC:2VA	None	LED (Red light lights up during ON)	0.3 mm ² , 2-core, outer dia. ø4 mm rear wiring	1.5m	Small relay, programmable controller	
	AG AX105							5m		
	AH AX111				Present	1.5m				
	AJ AX115					5m				
	AE AX125	DC:30V or less AC:120V or less	DC:40mA or less AC:20mA or less	2VA	None	None	None	5m		
	AK AX11A	AC:5 - 120 V	5 - 20mA					Present		LED (Red light lights up during ON)
	AL AX11B	DC:5 - 30 V	5 - 40mA	1.5W	Present	LED (Red light lights up during ON)	4-pin connector type, rear wiring	0.5m		
	5 WR525	DC:5 - 50 V AC:5 - 120 V	DC:3 - 40mA AC:3 - 20mA	DC:1.5W AC:2VA				None		LED (Red light lights up during ON)
	5F WR525F				5m					
	AP AZ101	DC:5 - 30 V AC:5 - 120 V	DC:5 - 40mA AC:5 - 20mA	DC:1.5W AC:2VA	None	LED (Red light lights up during ON)	0.3 mm ² , 2-core, outer dia. ø4 mm upper wiring	1.5m		
	AR AZ105							5m		
	AS AZ111				Present	1.5m				
	AT AZ115					5m				
	AN AZ125	DC:30V or less AC:120V or less	DC:40mA or less AC:20mA or less	2VA	None	None	None	5m		
	AU AZ11A	AC:5 - 120 V	5 - 20mA					Present		LED (Red light lights up during ON)
	AW AZ11B	DC:5 - 30 V	5 - 40mA	1.5W	Present	LED (Red light lights up during ON)	4-pin connector type, upper wiring	0.5m		
	8 WR535	DC:5 - 50 V AC:5 - 120 V	DC:3 - 40mA AC:3 - 20mA	DC:1.5W AC:2VA				None		LED (Red light lights up during ON)
	8F WR535F				5m					
No Contact	BE AX201	DC:5 - 30 V	5 - 40mA	-	Present	LED (Red light lights up during ON)	0.3 mm ² , 2-core, outer dia. ø4 mm rear wiring	1.5m	Small relay, programmable controller	
	BF AX205							5m		
	CE AX211							LED (2-lamp type in red/green)		1.5m
	CF AX215									5m
	2 WS235-1	DC:10 - 30 V	6 - 20mA	-	Present	LED (2-lamp type in red/green)	0.3 mm ² , 2-core, outer dia. ø4 mm rear wiring	5m		
	2F WS235-1F							5m		
	BM AZ201	DC:5 - 30 V	5 - 40mA	-	Present	LED (Red light lights up during ON)	0.3 mm ² , 2-core, outer dia. ø4 mm upper wiring	1.5m		
	BN AZ205							5m		
	CM AZ211							LED (2-lamp type in red/green)		1.5m
	CN AZ215									5m
RA AX205W	Cutting fluid proof type	-	-	Present	LED (Red light lights up during ON)	0.3 mm ² , 2-core, outer dia. ø4 mm rear wiring	5m			
RB AZ205W						0.3 mm ² , 2-core, outer dia. ø4 mm upper wiring	5m			
No Contact	1 WS245-1	DC:10 - 30 V	6 - 20mA	-	Present	LED (2-lamp type in red/green)	0.3 mm ² , 2-core, outer dia. ø4 mm upper wiring	5m		
	1F WS245-1F							5m		
No Contact (CE coformed)	CT AX211CE	DC:5 - 30 V	5 - 40mA	-	Present	LED (2-lamp type in red/green)	0.3 mm ² , 2-core, outer dia. ø4 mm rear wiring	1.5m		
	CU AX215CE							5m		
	CV AX21BCE							4-pin connector type, rear wiring	0.5m	
	CW AZ211CE							0.3 mm ² , 2-core, outer dia. ø4 mm upper wiring	1.5m	
	CX AZ215CE							5m		
	CY AZ21BCE							4-pin connector type, upper wiring	0.5m	

- Notes) ● For the switches without a protective circuit, be sure to provide the protective circuit (SK-100) with load devices when using induction load devices (relay, etc.).
 ● For the handling of switches, be sure to refer to the switch specifications in the end of this catalogue.
 ● The WR and WS type switches are cutting fluid proof type.
 ● We recommend AND UNIT (AU series) for multiple switches connected in series.

- For the switch symbol 9, pay attention to the points below when ordering the cutting fluid proof type switches, WR and WS types.

● General purpose type AX type (cord rear wiring)



AZ type (cord upper wiring)



● Cutting fluid proof type WR · WS type switch

- Cord rear wiring

WR525
WS235-1



- Cord upper wiring

WR535
WS245-1



- 5 WR525
8 WR535 The switch and straight box connector (F-SB) are combined [the flex tube (F-05: 4.8 m) is required].
2 WS235-1
1 WS245-1

- 5F WR525F
8F WR535F The flex tube (F-05: 4.8 m) is attached to the switch and straight box connector (F-SB).
2F WS235-1F
1F WS245-1F

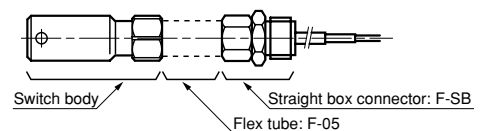

Standard stroke fabrication range (Single-rod)

Structure	Type	Mounting Type	Bore	Cylinder Stroke (mm)																Male Thread Type	
				5	10	15	20	25	30	35	40	45	50	60	70	80	90	100			
General purpose type	Standard type 160S-1	Basic type (SD)	φ20	○	○	○	○	○	○	○	○	○	○	□	—	—	—	—	○		
			φ25	○	○	○	○	○	○	○	○	○	○	○	□	□	—	—	—	○	
			φ32	○	○	○	○	○	○	○	○	○	○	○	○	○	○	○	○	○	
			φ40	○	○	○	○	○	○	○	○	○	○	○	○	○	○	○	○	○	
			φ50	○	○	○	○	○	○	○	○	○	○	○	○	○	○	○	○	○	
			φ63	○	○	○	○	○	○	○	○	○	○	○	○	○	○	○	○	○	
			φ80	○	○	○	○	○	○	○	○	○	○	○	○	○	○	○	○	○	
			φ100	□	□	□	□	□	□	□	□	□	□	□	□	□	□	□	□	□	
		φ125	□	□	□	□	□	□	□	□	□	□	□	—	—	—	—	—	□		
		Flange type (FA, FB)	φ20	○	○	○	○	○	○	○	○	○	○	○	□	—	—	—	—	○	
			φ25	○	○	○	○	○	○	○	○	○	○	○	□	□	—	—	—	○	
			φ32	○	○	○	○	○	○	○	○	○	○	○	○	○	○	○	○	○	
			φ40	○	○	○	○	○	○	○	○	○	○	○	○	○	○	○	○	○	
			φ50	○	○	○	○	○	○	○	○	○	○	○	○	○	○	○	○	○	
	φ63		○	○	○	○	○	○	○	○	○	○	○	○	○	○	○	○	○		
	Foot type (LD)	φ80	○	○	○	○	○	○	○	○	○	○	○	○	○	○	○	○	○		
		Foot type (LA)	φ32	○	○	○	○	○	○	○	○	○	○	○	□	□	□	□	□	○	
			φ40	○	○	○	○	○	○	○	○	○	○	○	□	□	□	□	□	○	
			φ50	○	○	○	○	○	○	○	○	○	○	○	□	□	□	□	□	○	
	φ63		○	○	○	○	○	○	○	○	○	○	○	□	□	□	□	□	○		
Switch set 160S-1R	Basic type (SD)	φ32	○	○	○	○	○	○	○	○	○	○	○	○	○	○	○	○	○		
		φ40	○	○	○	○	○	○	○	○	○	○	○	○	○	○	○	○	○		
		φ50	○	○	○	○	○	○	○	○	○	○	○	○	○	○	○	○	○		
		φ63	○	○	○	○	○	○	○	○	○	○	○	○	○	○	○	○	○		
	Flange type (FA, FB)	φ40	○	○	○	○	○	○	○	○	○	○	○	○	○	○	○	○	○		
		φ50	○	○	○	○	○	○	○	○	○	○	○	○	○	○	○	○	○		
		φ63	○	○	○	○	○	○	○	○	○	○	○	○	○	○	○	○	○		
		φ80	○	○	○	○	○	○	○	○	○	○	○	○	○	○	○	○	○		
Foot type (LD)	φ32	□	□	□	□	□	□	□	□	□	□	□	□	□	□	□	□	□			
	φ40	□	□	□	□	□	□	□	□	□	□	□	□	□	□	□	□	□			
	φ50	□	□	□	□	□	□	□	□	□	□	□	□	□	□	□	□	□			
	φ63	□	□	□	□	□	□	□	□	□	□	□	□	□	□	□	□	□			
Foot type (LA)	φ32	□	□	□	□	□	□	□	□	□	□	□	□	□	□	□	□	□			
	φ40	□	□	□	□	□	□	□	□	□	□	□	□	□	□	□	□	□			
	φ50	□	□	□	□	□	□	□	□	□	□	□	□	□	□	□	□	□			
	φ63	□	□	□	□	□	□	□	□	□	□	□	□	□	□	□	□	□			
Cutting fluid proof type	Standard type 160SW-1	Basic type (SD)	φ32	○	○	○	○	○	○	○	○	○	○	○	○	○	○	○	○		
			φ40	○	○	○	○	○	○	○	○	○	○	○	○	○	○	○	○		
			φ50	○	○	○	○	○	○	○	○	○	○	○	○	○	○	○	○	○	
			φ63	○	○	○	○	○	○	○	○	○	○	○	○	○	○	○	○	○	
		Flange type (FA, FB)	φ80	○	○	○	○	○	○	○	○	○	○	○	○	○	○	○	○	○	
			φ100	□	□	□	□	□	□	□	□	□	□	□	□	□	□	□	□	□	
			Foot type (LD)	φ32	○	○	○	○	○	○	○	○	○	○	○	○	○	○	○	○	○
				φ40	○	○	○	○	○	○	○	○	○	○	○	○	○	○	○	○	○
	φ50	○		○	○	○	○	○	○	○	○	○	○	○	○	○	○	○	○		
	φ63	○		○	○	○	○	○	○	○	○	○	○	○	○	○	○	○	○		
	Foot type (LA)	φ80	○	○	○	○	○	○	○	○	○	○	○	○	○	○	○	○	○		
		Switch set 160SW-1R	Basic type (SD)	φ32	○	○	○	○	○	○	○	○	○	○	○	○	○	○	○	○	
φ40				○	○	○	○	○	○	○	○	○	○	○	○	○	○	○	○		
φ50				○	○	○	○	○	○	○	○	○	○	○	○	○	○	○	○	○	
φ63	○			○	○	○	○	○	○	○	○	○	○	○	○	○	○	○	○		
Flange type (FA, FB)	φ80		○	○	○	○	○	○	○	○	○	○	○	○	○	○	○	○	○		
	Foot type (LD)		φ32	○	○	○	○	○	○	○	○	○	○	○	○	○	○	○	○	○	
			φ40	○	○	○	○	○	○	○	○	○	○	○	○	○	○	○	○	○	
			φ50	○	○	○	○	○	○	○	○	○	○	○	○	○	○	○	○	○	
φ63		○	○	○	○	○	○	○	○	○	○	○	○	○	○	○	○	○			
Foot type (LA)	φ80	○	○	○	○	○	○	○	○	○	○	○	○	○	○	○	○	○			

○: Standard manufacturing range, □: Range available for manufacturing for order

Available bore range at ST mounting. (Single-rod only/Made-to-order)

Structure	Type	Mounting Type	Bore	Cylinder Stroke (mm)										Male Thread Type				
				110	120	130	140	150	160	170	180	190	200					
General purpose type	Standard type 160S-1	Thread holes mounting (ST)	φ32	□	□	□	□	□	□	□	□	□	□	□	□	□	□	□
			φ40	□	□	□	□	□	□	□	□	□	□	□	□	□	□	□
			φ50	□	□	□	□	□	□	□	□	□	□	□	□	□	□	□
			φ63	□	□	□	□	□	□	□	□	□	□	□	□	□	□	□
			φ80	□	□	□	□	□	□	□	□	□	□	□	□	□	□	□
	Switch set 160S-1R	Thread holes mounting (ST)	φ32	□	□	□	□	□	□	□	□	□	□	□	□	□	□	□
			φ40	□	□	□	□	□	□	□	□	□	□	□	□	□	□	□
			φ50	□	□	□	□	□	□	□	□	□	□	□	□	□	□	□
			φ63	□	□	□	□	□	□	□	□	□	□	□	□	□	□	□
			φ80	□	□	□	□	□	□	□	□	□	□	□	□	□	□	□

□: Range available for manufacturing for order

Standard stroke fabrication range (Double-rod)

Structure	Type	Mounting Type	Bore	Cylinder Stroke (mm)														Male Thread Type		
				5	10	15	20	25	30	35	40	45	50	60	70	80	90		100	
General purpose type	Standard type 160S-1D	Basic type (SD)	φ20	○	○	○	○	○	○	□	□	□	□	□	—	—	—	—	○	
			φ25	○	○	○	○	○	○	□	□	□	□	□	□	—	—	—	—	○
			φ32	○	○	○	○	○	○	○	○	○	□	□	□	□	□	□	□	○
			φ40	○	○	○	○	○	○	○	○	○	□	□	□	□	□	□	□	○
			φ50	○	○	○	○	○	○	○	○	○	□	□	□	□	□	□	□	○
			φ63	○	○	○	○	○	○	○	○	○	□	□	□	□	□	□	□	○
			φ80	○	○	○	○	○	○	○	○	○	□	□	□	□	□	□	□	○
			φ100	□	□	□	□	□	□	□	□	□	□	□	□	□	□	□	□	□
		φ125	□	□	□	□	□	□	□	□	□	□	□	—	—	—	—	—	□	
		Flange type (FA)	φ20	○	○	○	○	○	○	□	□	□	□	□	—	—	—	—	○	
			φ25	○	○	○	○	○	○	□	□	□	□	□	□	—	—	—	○	
			φ32	○	○	○	○	○	○	○	○	○	□	□	□	□	□	□	○	
			φ40	○	○	○	○	○	○	○	○	○	□	□	□	□	□	□	○	
			φ50	○	○	○	○	○	○	○	○	○	□	□	□	□	□	□	○	
	φ63		○	○	○	○	○	○	○	○	○	□	□	□	□	□	□	○		
	Foot type (LD)	φ80	○	○	○	○	○	○	○	○	○	□	□	□	□	□	□	○		
		Foot type (LA)	φ32	□	□	□	□	□	□	□	□	□	□	□	□	□	□	□	□	
			φ40	□	□	□	□	□	□	□	□	□	□	□	□	□	□	□	□	
			φ50	□	□	□	□	□	□	□	□	□	□	□	□	□	□	□	□	
	φ63		□	□	□	□	□	□	□	□	□	□	□	□	□	□	□	□		
Switch set 160S-1RD	Basic type (SD)	φ32	□	□	□	□	□	□	□	□	□	□	□	□	□	□	□	□		
		φ40	□	□	□	□	□	□	□	□	□	□	□	□	□	□	□	□		
	Flange type (FA)	φ50	□	□	□	□	□	□	□	□	□	□	□	□	□	□	□	□		
		φ63	□	□	□	□	□	□	□	□	□	□	□	□	□	□	□	□		
	Foot type (LD)	φ80	□	□	□	□	□	□	□	□	□	□	□	□	□	□	□	□		
		φ80	□	□	□	□	□	□	□	□	□	□	□	□	□	□	□	□		
Cutting fluid proof type	Standard type 160SW-1D	Basic type (SD)	φ32	□	□	□	□	□	□	□	□	□	□	□	□	□	□	□		
			φ40	□	□	□	□	□	□	□	□	□	□	□	□	□	□	□		
			φ50	□	□	□	□	□	□	□	□	□	□	□	□	□	□	□		
			φ63	□	□	□	□	□	□	□	□	□	□	□	□	□	□	□		
			φ80	□	□	□	□	□	□	□	□	□	□	□	□	□	□	□		
			φ100	□	□	□	□	□	□	□	□	□	□	□	□	□	□	□		
		Flange type (FA)	φ32	□	□	□	□	□	□	□	□	□	□	□	□	□	□	□	□	
			φ40	□	□	□	□	□	□	□	□	□	□	□	□	□	□	□	□	
			Foot type (LD)	φ50	□	□	□	□	□	□	□	□	□	□	□	□	□	□	□	
				φ63	□	□	□	□	□	□	□	□	□	□	□	□	□	□	□	
	Switch set 160SW-1RD	Basic type (SD)	φ80	□	□	□	□	□	□	□	□	□	□	□	□	□	□	□		
			φ80	□	□	□	□	□	□	□	□	□	□	□	□	□	□	□		
		Flange type (FA)	φ32	□	□	□	□	□	□	□	□	□	□	□	□	□	□	□	□	
			φ40	□	□	□	□	□	□	□	□	□	□	□	□	□	□	□	□	
Foot type (LD)	φ50	□	□	□	□	□	□	□	□	□	□	□	□	□	□	□	□			
	φ63	□	□	□	□	□	□	□	□	□	□	□	□	□	□	□	□			

○: Standard manufacturing range, □: Range available for manufacturing for order

Adaptability of Working Oil to Packing Material

Packing Material	Adaptable Working Oil				
	Petroleum-based fluid	Water-glycol fluid	Phosphoric ester fluid	W/O Water in oil fluid	O/W Oil in water fluid
③ Fluoric rubber	○	×	○	○	○
⑥ Hydrogenated nitrile rubber	◎	◎	×	◎	◎

Notes) 1. The ◎ and ○ - marked items are applicable, while the × - marked items are inapplicable.
2. The ◎ - marked items are the recommended packing materials in case of giving the first priority to abrasion resistance.

★ How to order G screw piping port (only for SD type)

- Please specify the model as following.
ex. 160S-1 6SD63N30 - G
G screw piping port

Note) In some bores, the apparent dimensions are changed from their standard when you specify G screw. Please refer to the detailed dimension table in following pages.

★ How to order only lock nut

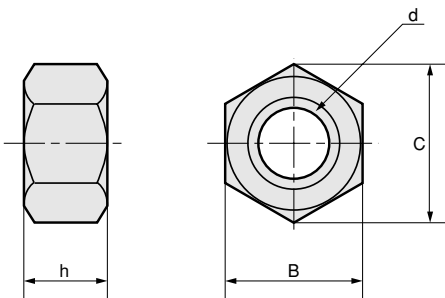

Cutting Fluid Proof Type/Adaptability of Cutting Fluid to Packing Material

Packing Material	Non-water Soluble Cutting Oil		Water Soluble Cutting Oil
	Type 1	Type 2	
⑥ Hydrogenated nitrile rubber	○	×	○

○ : applicable × : inapplicable

★ Specification of Air Vent (Option)

- The air vents are laid on the port surface and located symmetrical position to the port.

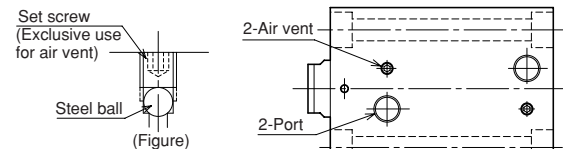

(Structure):
Single-rod, Double-rod
SD/LD/FA/FB type

Location of air vent on the same surface as piping port (Option)

Dimension Table

Bore	Part Model	d	B	C	h
ø20	LNH-10F-H	M10×1.25	17	19.6	6
ø25	LNH-12F-H	M12×1.25	19	21.9	7
ø32	LNH-16F-H	M16×1.5	22	25.4	10
ø40	LNH-20F-H	M20×1.5	27	31.2	12
ø50	LNH-24F-H	M24×1.5	32	37.0	14
ø63	LNH-30F-H	M30×1.5	41	47.3	17
ø80	LNH-39F-H	M39×1.5	55	68.5	20
ø100	LNH-48F-H	M48×1.5	70	80.8	26
ø125	LNH-64F-H	M64×2	90	104	35

Switch Mounting Minimum Possible Stroke

Bore	With A Switch			With Two Switches		
	AX and AZ types	WR type	WS type	AX and AZ types	WR type	WS type
ø32	5	5	10	10*	10	20
ø40						
ø50						
ø63						
ø80						

Note) • When attaching two switches of the WR or WS type, they cannot be attached to the same surface. (WR and WS type switches are not available for LA mounting.)

*If you would like to mount two switches to 10mm stroke cylinder, please.

Operating Ranges and Differences

Bore	Contact				No Contact					
	AX and AZ types		WR type		AX and AZ types		AX205W - AZ205W		WS type	
	Operating range	Difference	Operating range	Difference	Operating range	Difference	Operating range	Difference	Operating range	Difference
ø32	10 - 17	2 or less	10 - 17	2 or less	4 - 8	1 or less	15 - 22	2 or less	15 - 24	1 or less
ø40										
ø50										
ø63										
ø80							19 - 25			

Weight Table/General Purpose and Cutting Fluid Proof Types

Unit: kg

Bore (mm)	Basic type (SD)				Foot type (LA)				Mounting accessories additional weight		Rod end attachment additional weight	Added male thread weight
	Double Acting Single-rod		Double Acting Double-rod		Double Acting Single-rod		Double Acting Double-rod		Flange type (FA, FB)	Foot type (LD)	Separate flange joint (M type joint)	
	Basic weight	Added weight for each stroke of 1 mm	Basic weight	Added weight for each stroke of 1 mm	Basic weight	Added weight for each stroke of 1 mm	Basic weight	Added weight for each stroke of 1 mm				
ø20	0.6	0.013	0.7	0.014	—	—	—	—	0.25	0.46	0.2	0.015
ø25	0.8	0.016	1.0	0.017	—	—	—	—	0.30	0.58	0.3	0.026
ø32	1.4	0.025	1.6	0.024	1.4	0.027	1.9	0.028	0.62	1.09	0.3	0.057
ø40	1.8	0.030	2.1	0.032	1.8	0.034	2.4	0.036	1.16	1.42	0.4	0.114
ø50	2.5	0.037	2.7	0.036	2.6	0.044	3.3	0.048	1.60	2.43	0.6	0.201
ø63	3.8	0.047	4.1	0.041	4.1	0.062	5.0	0.068	2.02	3.30	0.8	0.435
ø80	6.6	0.067	7.6	0.083	—	—	—	—	3.77	5.86	1.4	0.798
ø100	12.5	0.102	14.9	0.121	—	—	—	—	—	—	3.0	—
ø125	21.5	0.152	29	0.222	—	—	—	—	—	—	5.3	—

Weight Table/Switch set

Unit: kg

Bore (mm)	Basic type (SD)				Foot type (LA)		Mounting accessories additional weight		Rod end attachment additional weight	Added male thread weight
	Double Acting Single-rod		Double Acting Double-rod		Double Acting Single-rod		Flange type (FA, FB)	Foot type (LD)	Separate flange joint (M type joint)	
	Basic weight	Added weight for each stroke of 1 mm	Basic weight	Added weight for each stroke of 1 mm	Basic weight	Added weight for each stroke of 1 mm				
ø32	1.2	0.022	1.3	0.024	1.2	0.022	0.62	1.09	0.3	0.057
ø40	1.6	0.028	1.7	0.031	1.6	0.028	1.16	1.42	0.4	0.114
ø50	2.2	0.036	2.4	0.041	2.3	0.036	1.60	2.43	0.6	0.201
ø63	3.3	0.049	3.7	0.057	3.6	0.049	2.02	3.30	0.8	0.435
ø80	6.2	0.071	7.2	0.084	—	—	3.77	5.86	1.4	0.798

Switch Added Weight Table

Unit: kg

AX · AZ Type			WR · WS Type
Cord length 1.5 m	Cord length 5 m	Connector type	
0.05	0.13	0.04	0.50

Formula Cylinder weight (kg) = Basic weight + (Cylinder stroke (mm) × Added weight for each stroke of 1 mm) + (Added switch weight × Number of switches)

Calculation example 160S-1R: Bore of ø40, cylinder stroke of 50 mm, AZ101 (cord length of 1.5 m), with two switches
 $1.6 + (50 \times 0.028) + (0.05 \times 2) = 3.10$ kg

Piston Pressurized Area Table

Unit: mm²

Bore (mm)	Rod Diameter (mm)	Double Acting Single-rod		Double Acting Double-rod	
		Push side	Pull side	Push side	Pull side
ø20	ø12	314	201	201	
ø25	ø14	491	337	337	
ø32	ø18	804	550	550	
ø40	ø22	1257	876	876	
ø50	ø28	1963	1348	1348	
ø63	ø36	3117	2100	2100	
ø80	ø45	5027	3436	3436	
ø100	ø56	7854	5391	5391	
ø125	ø70	12272	8424	8424	

Formula $F = A \cdot P \cdot \beta(N)$

F: Cylinder force (N)
 A: Piston pressurized area (mm²)
 P: Applied pressure (MPa)
 β: Load rate

Calculation example

Double acting single-rod, bore of ø40, applied pressure of 16 MPa, load rate of 0.8
 Push side cylinder force (N)
 $= 1257 \times 16 \times 0.8 = 16090$ (N)
 Pull side cylinder force (N)
 $= 876 \times 16 \times 0.8 = 11213$ (N)

16MPa Compact Design Hydraulic Cylinder

Double Acting Single-rod/Standard Type

Unit: mm

160S-1

30

Dimension Table

Symbol Bore	A	AE	BT	C	D	DE	E	EE	FB	FF	FG	KK		KL
												Female thread	Male thread	
ø20	15(25)	—	5.4	6	10	—	□44	Rc1/8	ø5.5	—	ø9.5	M8×1.25	M10×1.25	10
ø25	18(30)	—	5.4	6	12	—	□50	Rc1/8	ø5.5	—	ø9.5	M10×1.5	M12×1.25	12
ø32	25(40)	8	6.5	7	14	ø17.2	□62	Rc1/4	ø6.6	G1/8	ø11	M12×1.75	M16×1.5	15
ø40	30(45)	8	8.6	7	19	ø17.2	□70	Rc1/4	ø9	G1/8	ø14	M16×2	M20×1.5	20
ø50	35(50)	12	10.8	8	24	ø21.5	□80	Rc1/4	ø11	G1/4	ø17.5	M20×2.5	M24×1.5	24
ø63	45(60)	12	13	9	30	ø21.5	□94	Rc1/4	ø14	G1/4	ø20	M27×3	M30×1.5	33
ø80	60(80)	12	15.2	14	41	ø21.5	□114	Rc3/8	ø16	G1/4	ø23	M30×3.5	M39×1.5	36
ø100	75(95)	12	19.5	22	50	ø25.5	□140	Rc3/8	ø20	G3/8	ø29	M39×4	M48×1.5	45
ø125	95(125)	14	23.5	25	65	ø30	□172	Rc1/2	ø24	G1/2	ø35	M48×5	M64×2	58

Symbol Bore	LF	LL	MM	N		PJ		PL		TV	WF	Y	
				Rc thread	G thread	Rc thread	G thread	Rc thread	G thread			Rc thread	G thread
ø20	51	43	ø12	—	—	10.5	—	12	—	□30	8	20.5	—
ø25	53	45	ø14	—	—	12.5	—	12	—	□36	8	20.5	—
ø32	64	54	ø18	10	10	14	14	12	12	□47	10	28	28
ø40	65	55	ø22	10	10	16	16	12	12	□52	10	27	27
ø50	71	60	ø28	10	14	19	13.5	13	18.5	□58	11	28	28
ø63	80	67	ø36	10	16	24	20	13	17	□69	13	30	30
ø80	95	78	ø45	15	19	25	24	18	18	□86	17	35	36
ø100	122	96	ø56	15	18	26	26	28	28	□106	26	42	42
ø125	135	105	ø70	25	25	29	29	30	30	□132	30	46	46

- Notes)
- When you use the cylinder with lock nut, we recommend you change A dimension for parenthesis one.
 - The lock nut needs to be ordered separately.
 - 20mm and 25mm bore size of Cutting Fluid Proof Type are not available.
 - Allowance of MM is f8.

ST General purpose type 160S-1 6 ST Bore N Stroke T (ø32 - ø80/Made-to-order)

None : Female thread
T : Male thread

over 101 strokes (110, 120, 130, 140, 150, 160, 170, 180, 190, 200)

• Bore ø32 - ø80

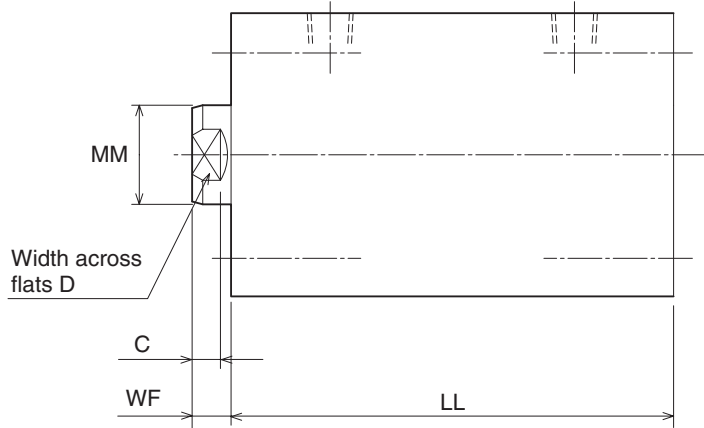
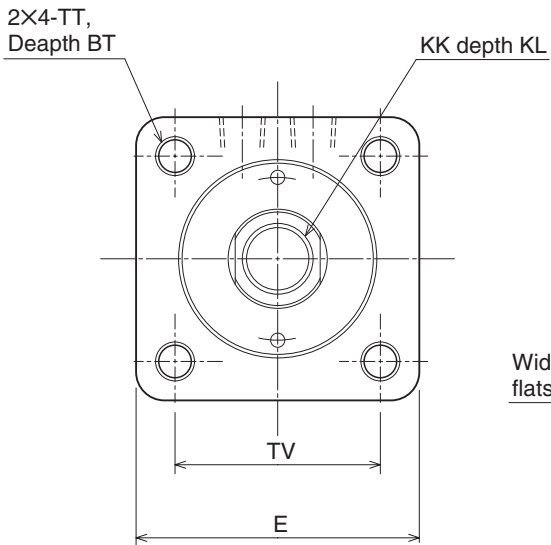
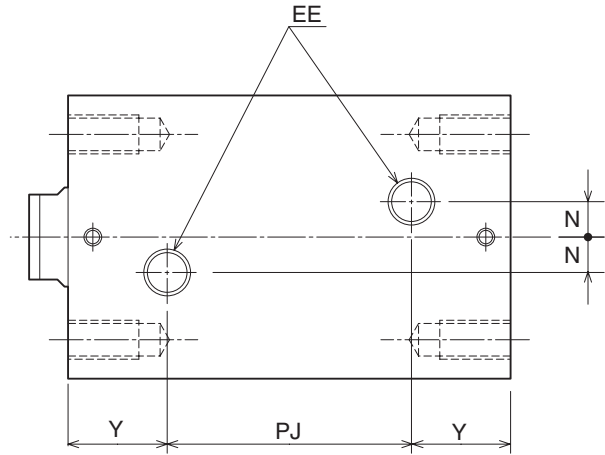
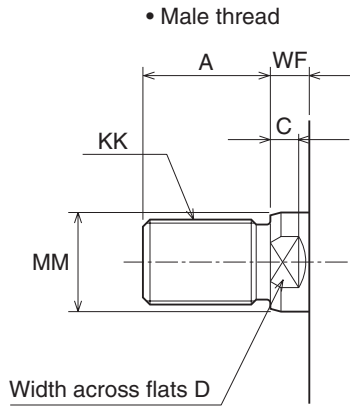

16MPa Compact Design Hydraulic Cylinder

Double Acting Single-rod/Standard Type

Unit: mm

160S-1

32

Dimension Table

Symbol Bore	A	BT	C	D	E	EE	KK		KL	MM	N	TT	TV	WF	Y
							Female thread	Male thread							
ø32	25(40)	15	7	14	□62	Rc1/4	M12×1.75	M16×1.5	15	ø18	10	M6×1	□47	10	28
ø40	30(45)	20	7	19	□70	Rc1/4	M16×2	M20×1.5	20	ø22	10	M8×1.25	□52	10	27
ø50	35(50)	25	8	24	□80	Rc1/4	M20×2.5	M24×1.5	24	ø28	10	M10×1.5	□58	11	28
ø63	45(60)	30	9	30	□94	Rc1/4	M27×3	M30×1.5	33	ø36	10	M12×1.75	□69	13	30
ø80	60(80)	35	14	41	□114	Rc3/8	M30×3.5	M39×1.5	36	ø45	15	M16×2	□86	17	35

Symbol Stroke Bore	LL										PJ									
	110	120	130	140	150	160	170	180	190	200	110	120	130	140	150	160	170	180	190	200
ø32	192	202	212	222	232	242	252	262	272	282	136	146	156	166	176	186	196	206	216	226
ø40	192	202	212	222	232	242	252	262	272	282	138	148	158	168	178	188	198	208	218	228
ø50	195	205	215	225	235	245	255	265	275	285	139	149	159	169	179	189	199	209	219	229
ø63	202	212	222	232	242	252	262	272	282	292	142	152	162	172	182	192	202	212	222	232
ø80	215	225	235	245	255	265	275	285	295	305	145	155	165	175	185	195	205	215	225	235

- Notes)
- When you use the cylinder with lock nut, we recommend you change A dimension for parenthesis one.
 - The lock nut needs to be ordered separately.
 - Allowance of MM is f8.

CAD/DATA
is available.



160S-1/THS16 Bore

LA General purpose type 160S-1 6 LA Bore N Stroke T (ø32 - ø63)

None : Female thread
T : Male thread

• Bore ø32 - ø63

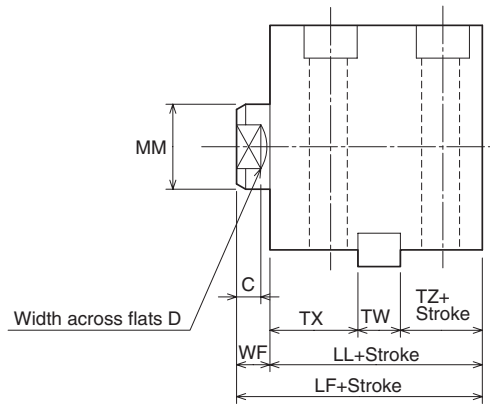
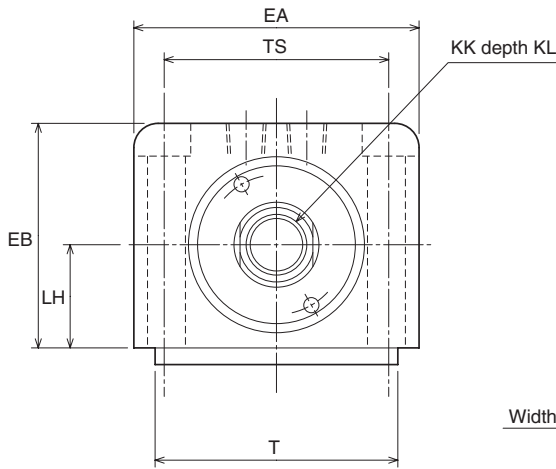
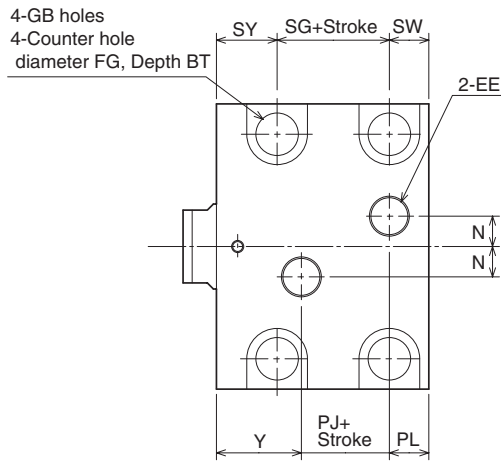
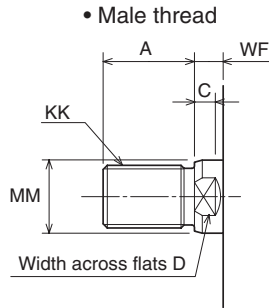

Dimension Table

Symbol Bore	A	BT	C	D	EA	EB	EE	FG	GB	KK		KL	LF	LH
										Female thread	Male thread			
ø32	25(40)	8.6	7	14	70	56	Rc1/4	ø14	ø9	M12×1.75	M16×1.5	15	64	25±0.06
ø40	30(45)	10.8	7	19	80	64	Rc1/4	ø17.5	ø11	M16×2	M20×1.5	20	65	29±0.06
ø50	35(50)	13	8	24	94	74	Rc1/4	ø20	ø14	M20×2.5	M24×1.5	24	71	34±0.06
ø63	45(60)	15.2	9	30	114	89	Rc1/4	ø23	ø16	M27×3	M30×1.5	33	80	42±0.06

Symbol Bore	LL	MM	N	PJ	PL	SG	SW	SY	T	TS	TW	TX	TZ	WF	Y
ø32	54	ø18	10	14	12	24	10	20	63	56	12	28	14	10	28
ø40	55	ø22	10	16	12	23	12	20	70	62	12	28	15	10	27
ø50	60	ø28	10	19	13	27	13	20	80	74	14	29	17	11	28
ø63	67	ø36	10	24	13	32	15	20	100	90	16	31	20	13	30

- Notes)
- When you use the cylinder with lock nut, we recommend you change A dimension for parenthesis one.
 - The lock nut needs to be ordered separately.
 - Allowance of MM is f8.

Recommended Key Way Dimensions

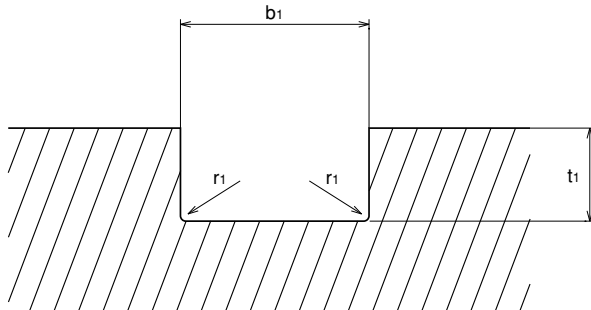

When using a parallel key:

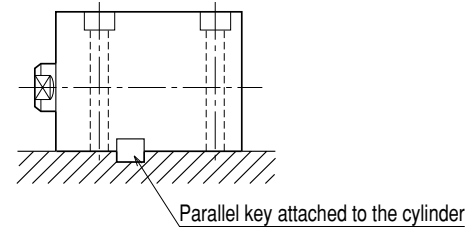

When not using a parallel key:

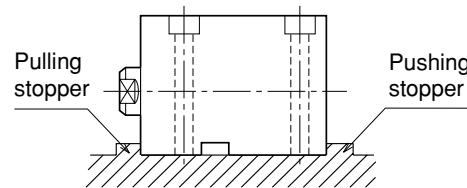

Use the same dimensions for the stopper as the attached parallel key.

Dimension Table

Bore	Key's Nominal Dimensions b × h × 1	Key Way Dimensions		
		b ₁	t ₁	r ₁
ø32	12×8×63 (Both rounded)	12 ⁰ _{-0.043}	5 ^{+0.2} ₀	0.25 - 0.40
ø40	12×8×70 (Both rounded)	12 ⁰ _{-0.043}	5 ^{+0.2} ₀	
ø50	14×9×80 (Both rounded)	14 ⁰ _{-0.043}	5.5 ^{+0.2} ₀	
ø63	16×10×100 (Both rounded)	16 ⁰ _{-0.043}	6 ^{+0.2} ₀	

- When using the foot type, use the attached parallel key to install the cylinder, referring to the "Recommended Key Way Dimensions."
- When not using the parallel key, attach the stoppers to the cylinder's front and rear sides toward its stroke direction. If the cylinder is used without using the key or stoppers, a large force is applied to the cylinder's mounting bolts, possibly resulting in the fracturing of the bolts.

CAD/DATA is available.



160S-1/THS16 Bore

LD

General purpose type 160S-1 6 LD Bore N Stroke T (ø20 - ø80)

Cutting fluid proof type 160SW-1 6 LD Bore N Stroke T (ø32 - ø80)

None : Female thread
T : Male thread

• Bore ø20, ø25

• Male thread

• Less than 15 strokes

• Over 15 strokes

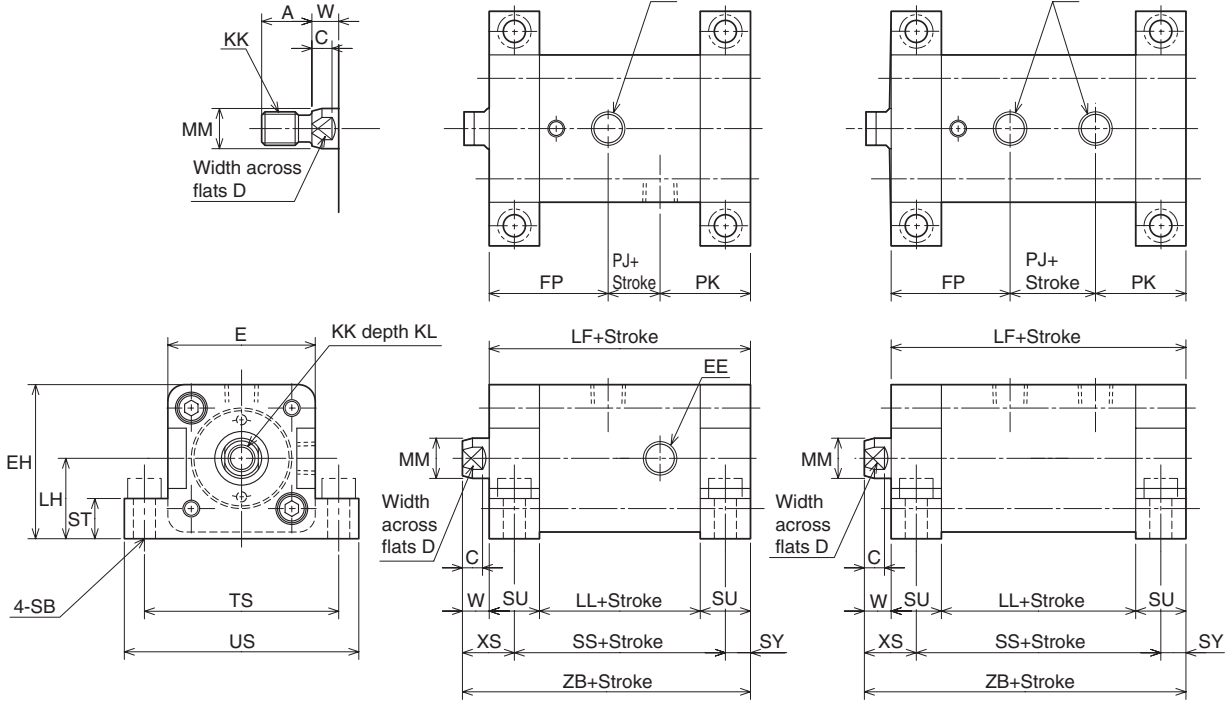

• Bore ø32 - ø80

• Male thread

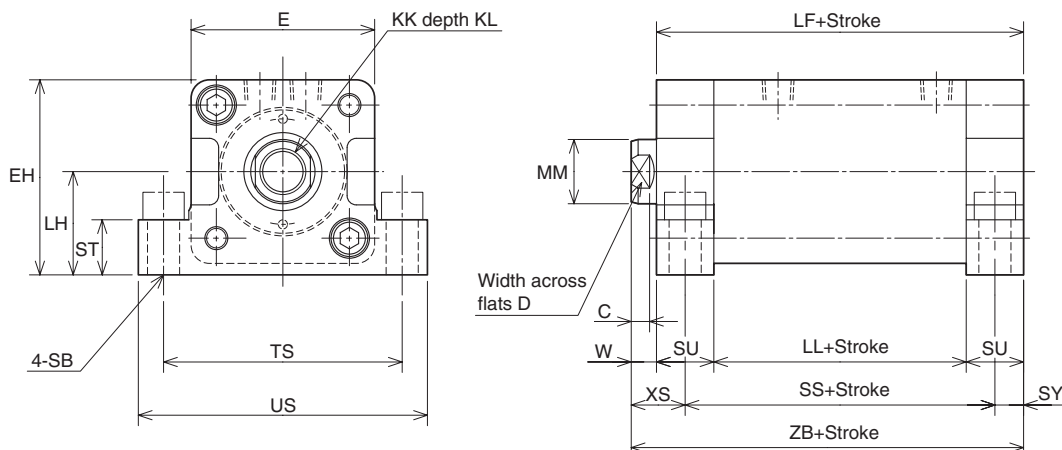
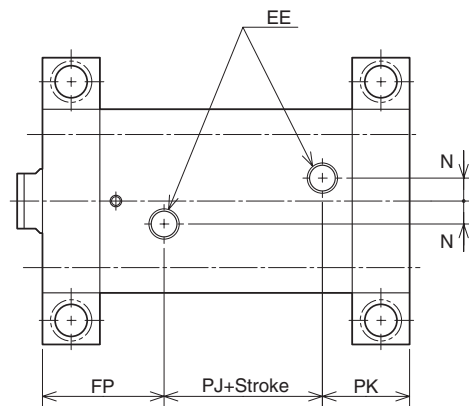
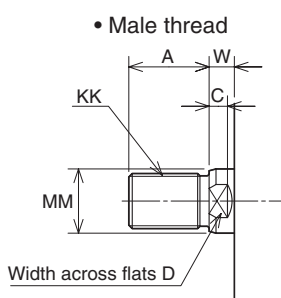

*Please be sure to use the Socket Head Screw when install the cylinder to the contact patch.

16MPa Compact Design Hydraulic Cylinder

Double Acting Single-rod/Standard Type

Unit: mm

160S-1

36

Dimension Table

Symbol Bore	A	C	D	E	EE	EH	FP	KK		KL	LF	LH
								Female thread	Male thread			
ø20	15(25)	6	10	□44	Rc1/8	46	35.5	M8×1.25	M10×1.25	10	73	24±0.15
ø25	18(30)	6	12	□50	Rc1/8	52	35.5	M10×1.5	M12×1.25	12	75	27±0.15
ø32	25(40)	7	14	□62	Rc1/4	66	48	M12×1.75	M16×1.5	15	94	35±0.15
ø40	30(45)	7	19	□70	Rc1/4	72.5	47	M16×2	M20×1.5	20	95	37.5±0.15
ø50	35(50)	8	24	□80	Rc1/4	85	53	M20×2.5	M24×1.5	24	110	45±0.15
ø63	45(60)	9	30	□94	Rc1/4	97	55	M27×3	M30×1.5	33	117	50±0.15
ø80	60(80)	14	41	□114	Rc3/8	117	65	M30×3.5	M39×1.5	36	138	60±0.25

Symbol Bore	LL	MM	N	PJ	PK	SB	SS	ST	SU	SY	TS	US	W	XS	ZB
ø20	43	ø12	—	10.5	27	6.6	58	12	15	7.5	58	70	8	15.5	81
ø25	45	ø14	—	12.5	27	6.6	60	12	15	7.5	64	76	8	15.5	83
ø32	54	ø18	10	14	32	9	74	16	20	10	79	94	10	20	104
ø40	55	ø22	10	16	32	11	75	20	20	10	90	108	10	20	105
ø50	60	ø28	10	19	38	14	85	24	25	12.5	104	126	11	23.5	121
ø63	67	ø36	10	24	38	16	92	30	25	12.5	121	146	13	25.5	130
ø80	78	ø45	15	25	48	18	108	35	30	15	144	172	17	32	155

- Notes)
- When you use the cylinder with lock nut, we recommend you change A dimension for parenthesis one.
 - The lock nut needs to be ordered separately.
 - 20mm and 25mm bore size of Cutting Fluid Proof Type are not available.
 - Allowance of MM is f8.

CAD/DATA is available.



160S-1/THS16 Bore

FA

General purpose type 160S-1 6 FA Bore N Stroke T (ø20 - ø80)

Cutting fluid proof type 160SW-1 6 FA Bore N Stroke T (ø32 - ø80)

None : Female thread
T : Male thread

• Bore ø20, ø25

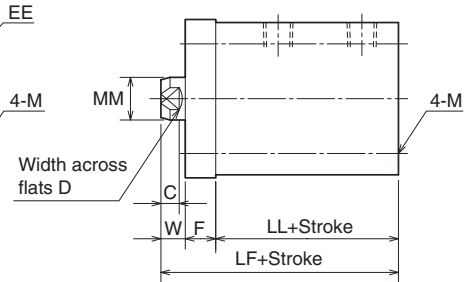
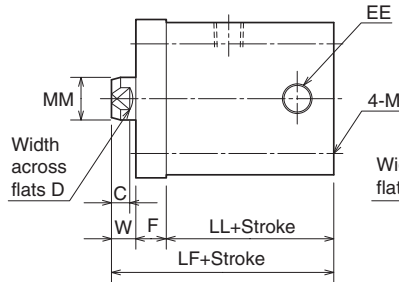
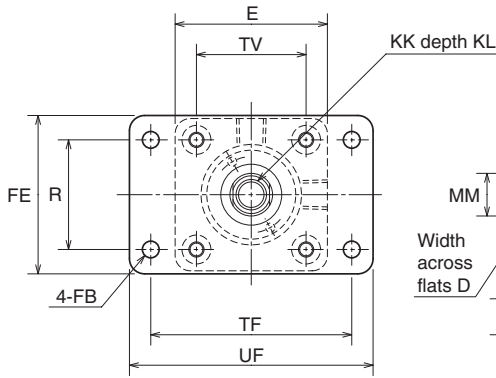
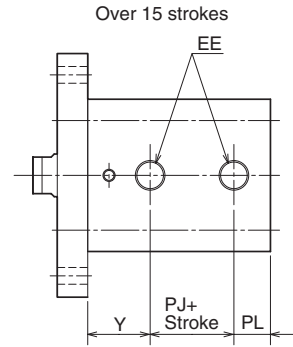
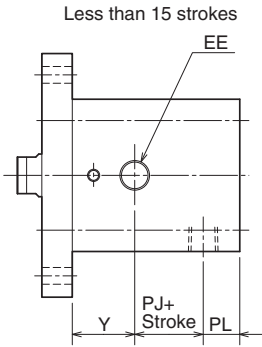
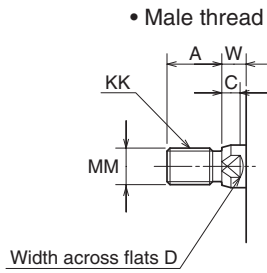

• Bore ø32 - ø80

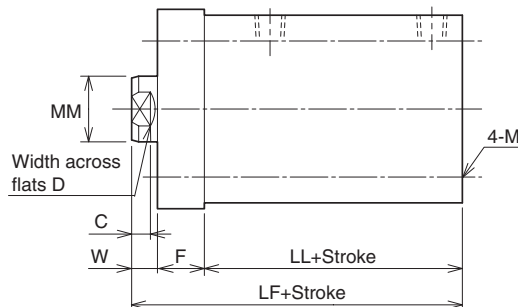
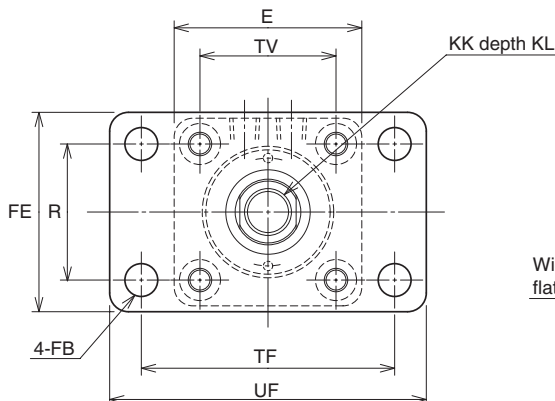
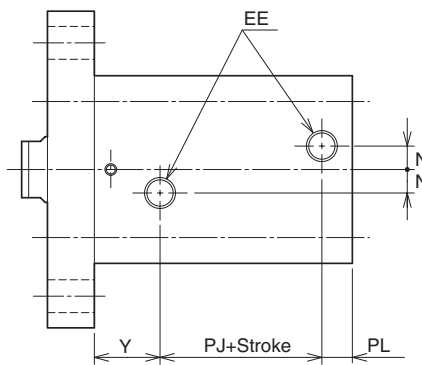
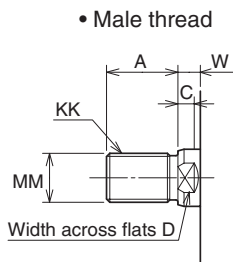

16MPa Compact Design Hydraulic Cylinder

Double Acting Single-rod/Standard Type

Unit: mm

160S-1

38

Dimension Table

Symbol Bore	A	C	D	E	EE	F	FB	FE	KK		KL	LF
									Female thread	Male thread		
ø20	15(25)	6	10	□ 44	Rc1/8	10	ø5.5	46	M8×1.25	M10×1.25	10	61
ø25	18(30)	6	12	□ 50	Rc1/8	10	ø5.5	52	M10×1.5	M12×1.25	12	63
ø32	25(40)	7	14	□ 62	Rc1/4	15	ø6.6	62	M12×1.75	M16×1.5	15	79
ø40	30(45)	7	19	□ 70	Rc1/4	20	ø11	70	M16×2	M20×1.5	20	85
ø50	35(50)	8	24	□ 80	Rc1/4	20	ø14	85	M20×2.5	M24×1.5	24	91
ø63	45(60)	9	30	□ 94	Rc1/4	20	ø14	98	M27×3	M30×1.5	33	100
ø80	60(80)	14	41	□ 114	Rc3/8	25	ø18	118	M30×3.5	M39×1.5	36	120

Symbol Bore	LL	M	MM	N	PJ	PL	R	TF	TV	UF	W	Y
ø20	43	M5×0.8	ø12	—	10.5	12	30	60	□30	75	8	20.5
ø25	45	M5×0.8	ø14	—	12.5	12	36	66	□36	80	8	20.5
ø32	54	M6×1	ø18	10	14	12	40	80	□47	95	10	28
ø40	55	M8×1.25	ø22	10	16	12	46	96	□52	118	10	27
ø50	60	M10×1.5	ø28	10	19	13	58	108	□58	135	11	28
ø63	67	M12×1.75	ø36	10	24	13	65	124	□69	150	13	30
ø80	78	M14×2	ø45	15	25	18	87	154	□86	185	17	35

- Notes)
- When you use the cylinder with lock nut, we recommend you change A dimension for parenthesis one.
 - The lock nut needs to be ordered separately.
 - 20mm and 25mm bore size of Cutting Fluid Proof Type are not available.
 - Allowance of MM is f8.

CAD/DATA is available.



160S-1/THS16 Bore

FB

General purpose type 160S-1 6 FB Bore N Stroke T (ø20 - ø80)

Cutting fluid proof type 160SW-1 6 FB Bore N Stroke T (ø32 - ø80)

None : Female thread
T : Male thread

• Bore ø20, ø25

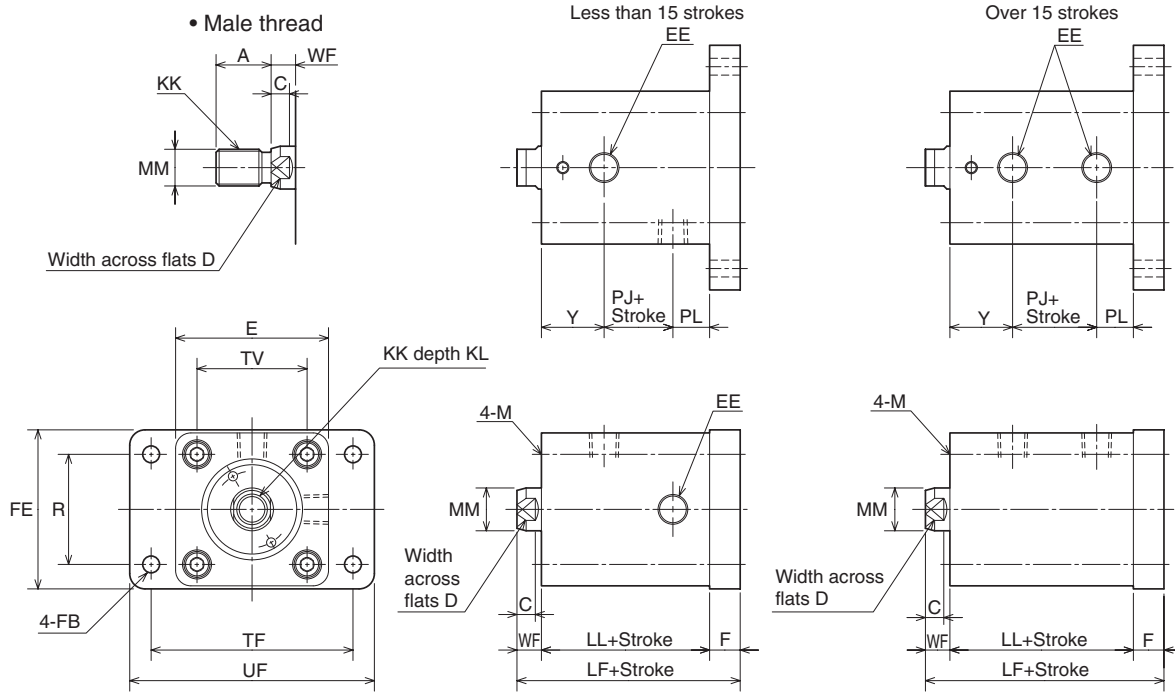

• Bore ø32 - ø80

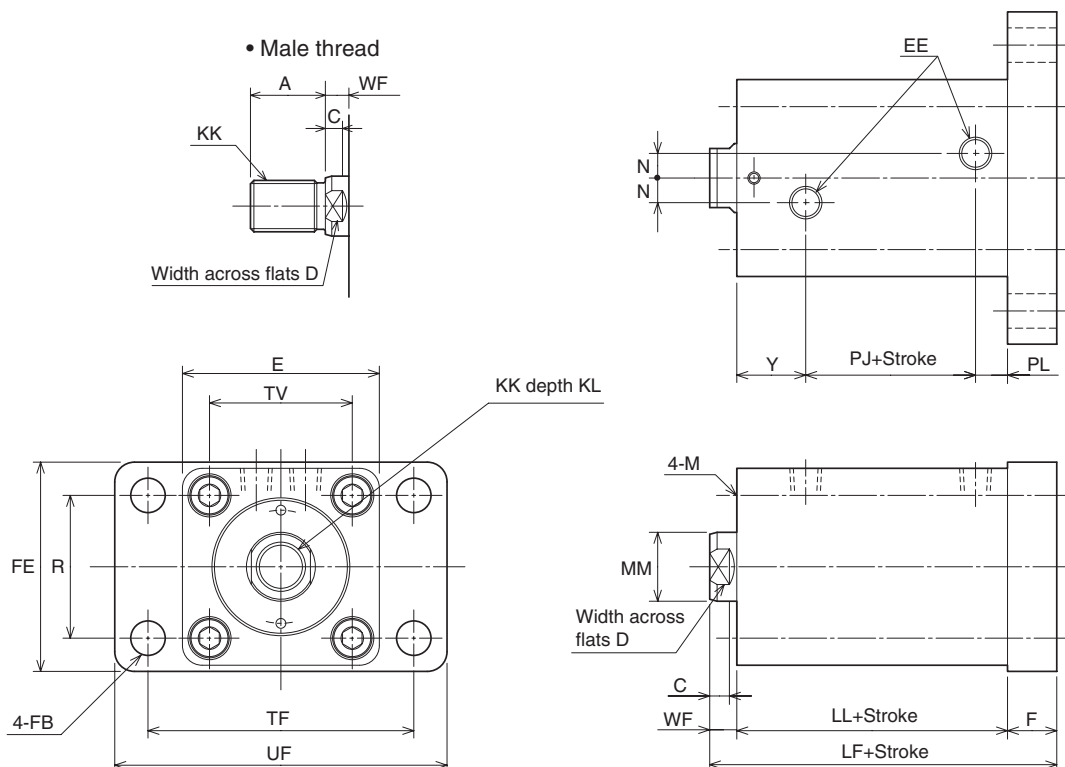

Dimension Table

Symbol Bore	A	C	D	E	EE	F	FB	FE	KK		KL	LF
									Female thread	Male thread		
ø20	15(25)	6	10	□44	Rc1/8	10	φ5.5	46	M8×1.25	M10×1.25	10	61
ø25	18(30)	6	12	□50	Rc1/8	10	φ5.5	52	M10×1.5	M12×1.25	12	63
ø32	25(40)	7	14	□62	Rc1/4	15	φ6.6	62	M12×1.75	M16×1.5	15	79
ø40	30(45)	7	19	□70	Rc1/4	20	φ11	70	M16×2	M20×1.5	20	85
ø50	35(50)	8	24	□80	Rc1/4	20	φ14	85	M20×2.5	M24×1.5	24	91
ø63	45(60)	9	30	□94	Rc1/4	20	φ14	98	M27×3	M30×1.5	33	100
ø80	60(80)	14	41	□114	Rc3/8	25	φ18	118	M30×3.5	M39×1.5	36	120

Symbol Bore	LL	M	MM	N	PJ	PL	R	TF	TV	UF	WF	Y
ø20	43	M5×0.8	φ12	—	10.5	12	30	60	□30	75	8	20.5
ø25	45	M5×0.8	φ14	—	12.5	12	36	66	□36	80	8	20.5
ø32	54	M6×1	φ18	10	14	12	40	80	□47	95	10	28
ø40	55	M8×1.25	φ22	10	16	12	46	96	□52	118	10	27
ø50	60	M10×1.5	φ28	10	19	13	58	108	□58	135	11	28
ø63	67	M12×1.75	φ36	10	24	13	65	124	□69	150	13	30
ø80	78	M14×2	φ45	15	25	18	87	154	□86	185	17	35

- Notes)
- When you use the cylinder with lock nut, we recommend you change A dimension for parenthesis one.
 - The lock nut needs to be ordered separately.
 - 20mm and 25mm bore size of Cutting Fluid Proof Type are not available.
 - Allowance of MM is f8.

Dimension Table

Symbol Bore	A	AE	BT	C	D	DE	E	EE	FB	FF	FG	KK		KL
												Female thread	Male thread	
ø20	15(25)	–	5.4	6	10	–	□44	Rc1/8	ø5.5	–	ø9.5	M8×1.25	M10×1.25	10
ø25	18(30)	–	5.4	6	12	–	□50	Rc1/8	ø5.5	–	ø9.5	M10×1.5	M12×1.25	12
ø32	25(40)	8	6.5	7	14	ø17.2	□62	Rc1/4	ø6.6	G1/8	ø11	M12×1.75	M16×1.5	15
ø40	30(45)	8	8.6	7	19	ø17.2	□70	Rc1/4	ø9	G1/8	ø14	M16×2	M20×1.5	20
ø50	35(50)	12	10.8	8	24	ø21.5	□80	Rc1/4	ø11	G1/4	ø17.5	M20×2.5	M24×1.5	24
ø63	45(60)	12	13	9	30	ø21.5	□94	Rc1/4	ø14	G1/4	ø20	M27×3	M30×1.5	33
ø80	60(80)	12	15.2	14	41	ø21.5	□114	Rc3/8	ø16	G1/4	ø23	M30×3.5	M39×1.5	36
ø100	75(95)	12	19.5	22	50	ø25.5	□140	Rc3/8	ø20	G3/8	ø29	M39×4	M48×1.5	45
ø125	95(125)	14	23.5	25	65	ø30	□172	Rc1/2	ø24	G1/2	ø35	M48×5	M64×2	58

Symbol Bore	LL	MM	N		PJ		TV	WF	Y	
			Rc thread	G thread	Rc thread	G thread			Rc thread	G thread
ø20	54	ø12	–	–	13	–	□30	8	20.5	–
ø25	56	ø14	–	–	15	–	□36	8	20.5	–
ø32	72	ø18	10	10	16	16	□47	10	28	28
ø40	72	ø22	10	10	18	18	□52	10	27	27
ø50	75	ø28	10	14	19	19	□58	11	28	28
ø63	82	ø36	10	16	22	22	□69	13	30	30
ø80	95	ø45	15	19	25	23	□86	17	35	36
ø100	108	ø56	15	18	24	24	□106	26	42	42
ø125	120	ø70	25	25	28	28	□132	30	46	46

- Notes)
- When you use the cylinder with lock nut, we recommend you change A dimension for parenthetic one.
 - The lock nut needs to be ordered separately.
 - 20mm and 25mm bore size of Cutting Fluid Proof Type are not available.
 - Allowance of MM is f8.

CAD/DATA
is available.



160S-1/THS16 Bore

LA

General purpose type 160S-1D

6

LA

Bore

N

Stroke

T (ø32 - ø63)

None : Female thread
T : Male thread

• Bore ø32 - ø63

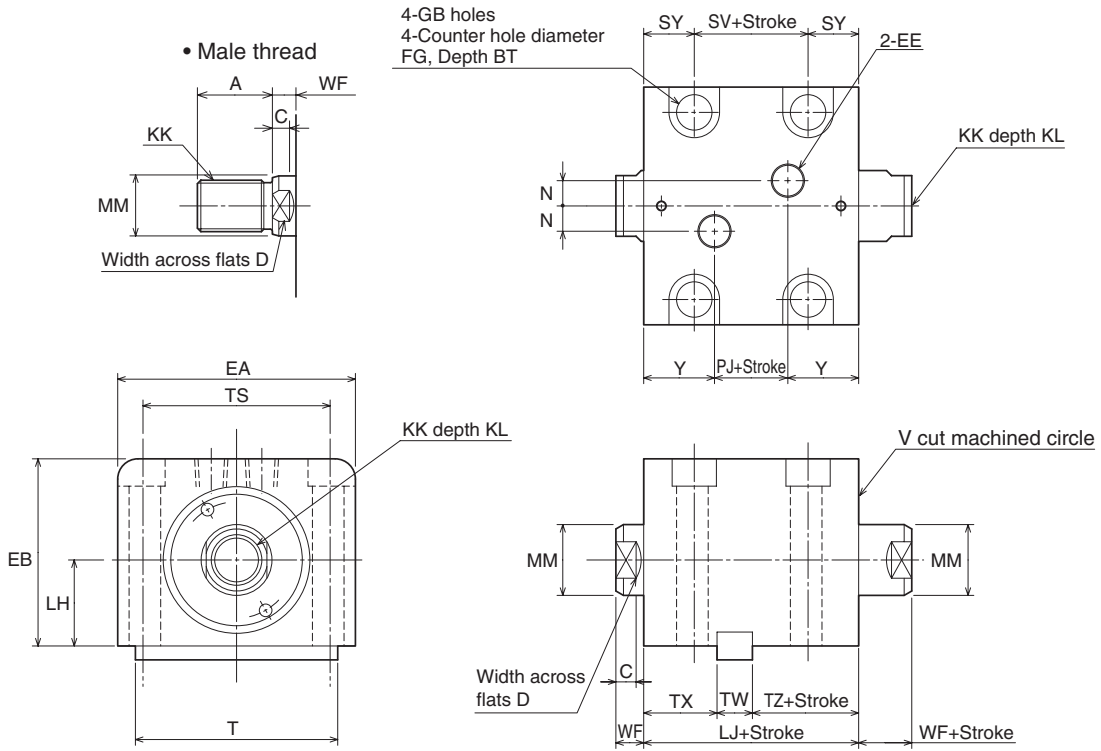

Dimension Table

Symbol Bore	A	BT	C	D	EA	EB	EE	FG	GB	KK		KL
										Female thread	Male thread	
ø32	25(40)	8.6	7	14	70	56	Rc1/4	ø14	ø9	M12×1.75	M16×1.5	15
ø40	30(45)	10.8	7	19	80	64	Rc1/4	ø17.5	ø11	M16×2	M20×1.5	20
ø50	35(50)	13	8	24	94	74	Rc1/4	ø20	ø14	M20×2.5	M24×1.5	24
ø63	45(60)	15.2	9	30	114	89	Rc1/4	ø23	ø16	M27×3	M30×1.5	33

Symbol Bore	LH	LJ	MM	N	PJ	SV	SY	T	TS	TW	TX	TZ	WF	Y
ø32	25±0.06	72	ø18	10	16	32	20	63	56	12	28	32	10	28
ø40	29±0.06	72	ø22	10	18	32	20	70	62	12	28	32	10	27
ø50	34±0.06	75	ø28	10	19	35	20	80	74	14	29	32	11	28
ø63	42±0.06	82	ø36	10	22	42	20	100	90	16	31	35	13	30

- Notes)
- When you use the cylinder with lock nut, we recommend you change A dimension for parenthesis one.
 - The lock nut needs to be ordered separately.
 - Allowance of MM is f8.

Recommended Key Way Dimensions

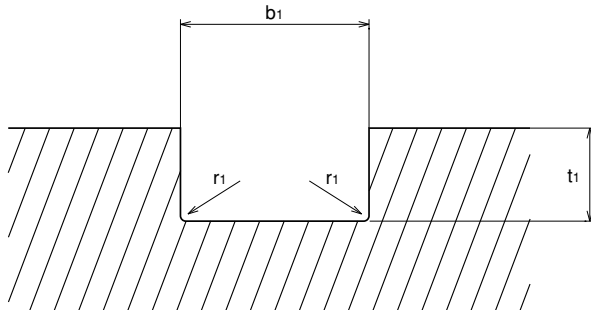

When using a parallel key:

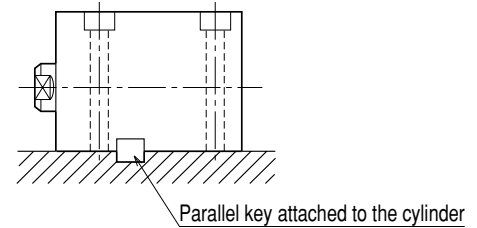

When not using a parallel key:

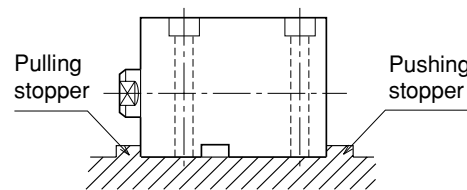

Use the same dimensions for the stopper as the attached parallel key.

Dimension Table

Bore	Key's Nominal Dimensions b × h × 1	Key Way Dimensions		
		b ₁	t ₁	r ₁
ø32	12×8×63 (Both rounded)	12 ⁰ _{-0.043}	5 ^{+0.2} ₀	0.25 - 0.40
ø40	12×8×70 (Both rounded)	12 ⁰ _{-0.043}	5 ^{+0.2} ₀	
ø50	14×9×80 (Both rounded)	14 ⁰ _{-0.043}	5.5 ^{+0.2} ₀	
ø63	16×10×100 (Both rounded)	16 ⁰ _{-0.043}	6 ^{+0.2} ₀	

- When using the foot type, use the attached parallel key to install the cylinder, referring to the "Recommended Key Way Dimensions."
- When not using the parallel key, attach the stoppers to the cylinder's front and rear sides toward its stroke direction. If the cylinder is used without using the key or stoppers, a large force is applied to the cylinder's mounting bolts, possibly resulting in the fracturing of the bolts.

CAD/DATA is available.



160S-1/THS16

LD

General purpose type 160S-1D LD N (ø20 - ø80)

Cutting fluid proof type 160SW-1D LD N (ø32 - ø80)

None : Female thread
 : Male thread

• Bore ø20, ø25

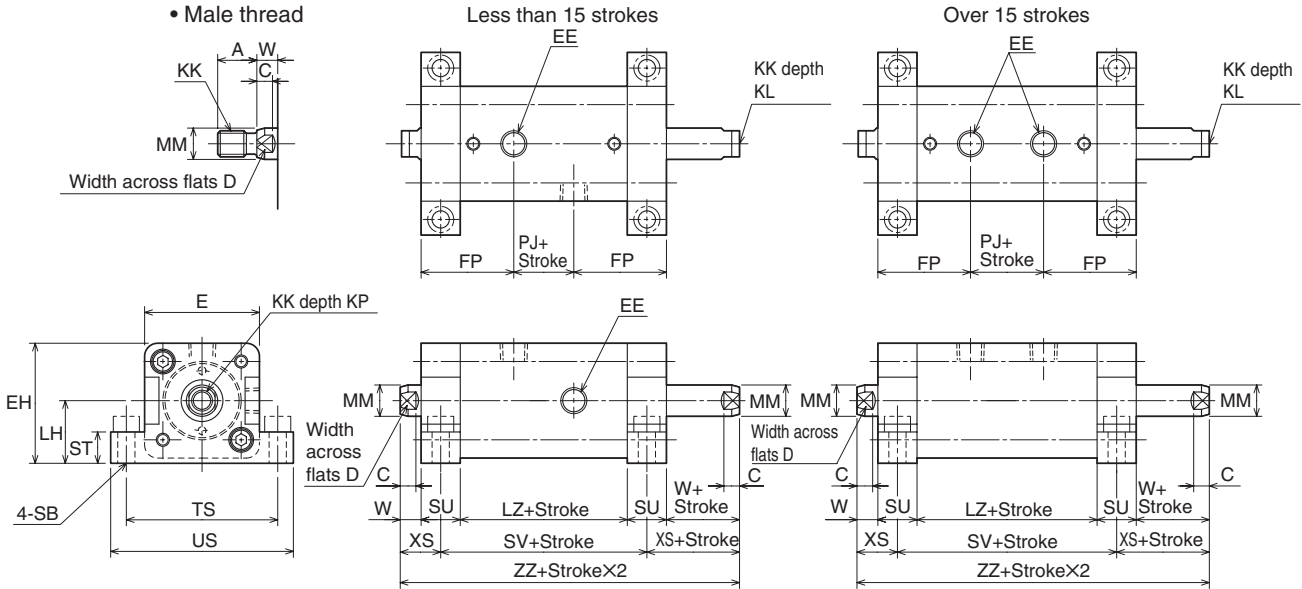

• Bore ø32 - ø80

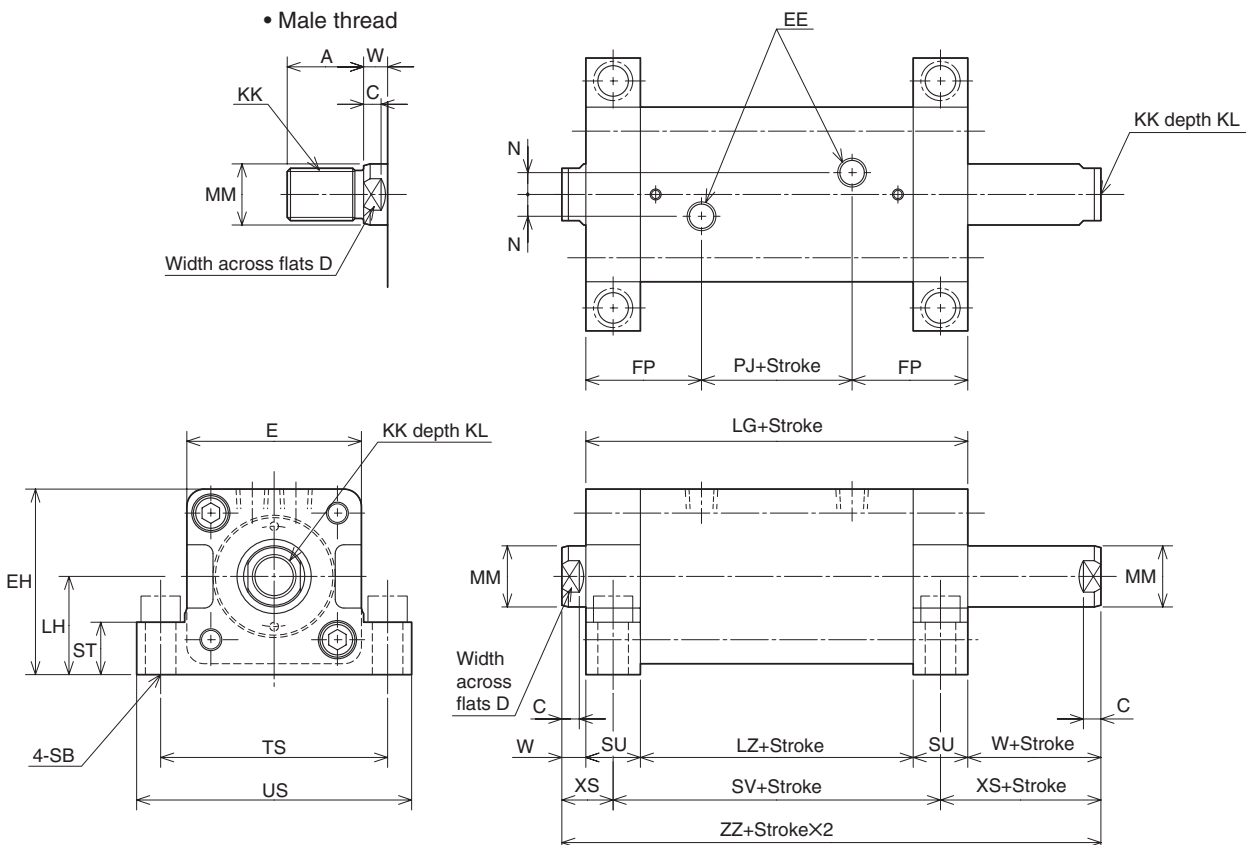

*Please be sure to use the Socket Head Screw when install the cylinder to the contact patch.

Dimension Table

Symbol Bore	A	C	D	E	EE	EH	FP	KK		KL	LG	LH
								Female thread	Male thread			
∅20	15(25)	6	10	□44	Rc1/8	46	33.5	M8×1.25	M10×1.25	10	84	24±0.15
∅25	18(30)	6	12	□50	Rc1/8	52	35.5	M10×1.5	M12×1.25	12	86	27±0.15
∅32	25(40)	7	14	□62	Rc1/4	66	48	M12×1.75	M16×1.5	15	112	35±0.15
∅40	30(45)	7	19	□70	Rc1/4	72.5	47	M16×2	M20×1.5	20	112	37.5±0.15
∅50	35(50)	8	24	□80	Rc1/4	85	53	M20×2.5	M24×1.5	24	125	45±0.15
∅63	45(60)	9	30	□94	Rc1/4	97	55	M27×3	M30×1.5	33	132	50±0.15
∅80	60(80)	14	41	□114	Rc3/8	117	65	M30×3.5	M39×1.5	36	155	60±0.25

Symbol Bore	LZ	MM	N	PJ	SB	ST	SU	SV	TS	US	W	XS	ZZ
∅20	54	∅12	—	13	6.6	12	15	69	58	70	8	15.5	100
∅25	56	∅14	—	15	6.6	12	15	71	64	76	8	15.5	102
∅32	72	∅18	10	16	9	16	20	92	79	94	10	20	132
∅40	72	∅22	10	18	11	20	20	92	90	108	10	20	132
∅50	75	∅28	10	19	14	24	25	100	104	126	11	23.5	147
∅63	82	∅36	10	22	16	30	25	107	121	146	13	25.5	158
∅80	95	∅45	15	25	18	35	30	125	144	172	17	32	189

- Notes)
- When you use the cylinder with lock nut, we recommend you change A dimension for parenthesis one.
 - The lock nut needs to be ordered separately.
 - 20mm and 25mm bore size of Cutting Fluid Proof Type are not available.
 - Allowance of MM is f8.

CAD/DATA is available.



160S-1/THS16 Bore

FA

General purpose type 160S-1D 6 FA Bore N Stroke T (ø20 - ø80)

Cutting fluid proof type 160SW-1D 6 FA Bore N Stroke T (ø32 - ø80)

None : Female thread
T : Male thread

• Bore ø20, ø25

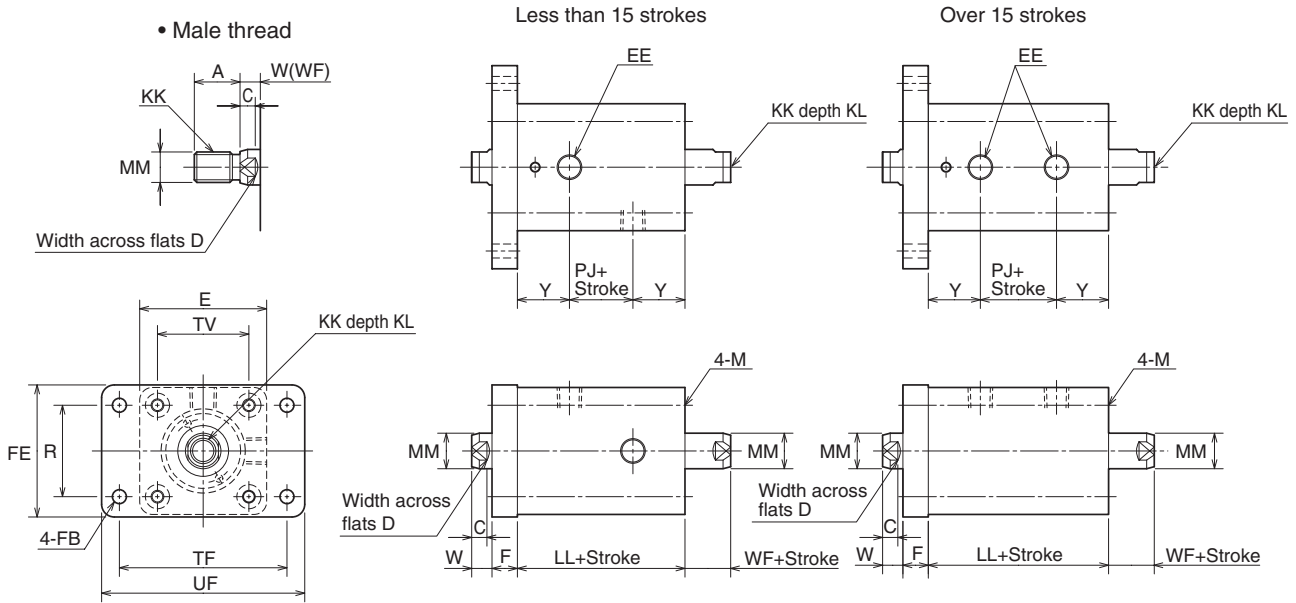

• Bore ø32 - ø80

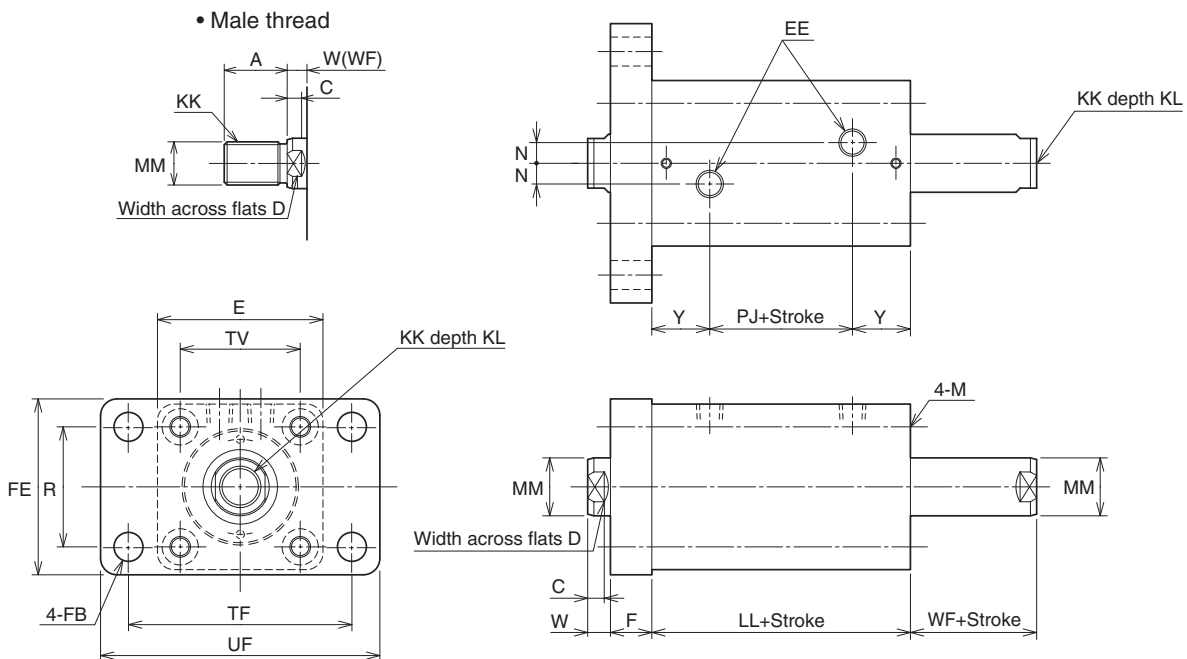

16MPa Compact Design Hydraulic Cylinder

Double Acting Double-rod/Standard Type

Unit: mm

160S-1

48

Dimension Table

Symbol Bore	A	C	D	E	EE	F	FB	FE	KK		KL
									Female thread	Male thread	
ø20	15(25)	6	10	□44	Rc1/8	10	ø5.5	46	M8×1.25	M10×1.25	10
ø25	18(30)	6	12	□50	Rc1/8	10	ø5.5	52	M10×1.5	M12×1.25	12
ø32	25(40)	7	14	□62	Rc1/4	15	ø6.6	62	M12×1.75	M16×1.5	15
ø40	30(45)	7	19	□70	Rc1/4	20	ø11	70	M16×2	M20×1.5	20
ø50	35(50)	8	24	□80	Rc1/4	20	ø14	85	M20×2.5	M24×1.5	24
ø63	45(60)	9	30	□94	Rc1/4	20	ø14	98	M27×3	M30×1.5	33
ø80	60(80)	14	41	□114	Rc3/8	25	ø18	118	M30×3.5	M39×1.5	36

Symbol Bore	LL	M	MM	N	PJ	R	TF	TV	UF	W	WF	Y
ø20	54	M5×0.8	ø12	–	13	30	60	□30	75	8	8	20.5
ø25	56	M5×0.8	ø14	–	15	36	66	□36	80	8	8	20.5
ø32	72	M6×1	ø18	10	16	40	80	□47	95	10	10	28
ø40	72	M8×1.25	ø22	10	18	46	96	□52	118	10	10	27
ø50	75	M10×1.25	ø28	10	19	58	108	□58	135	11	11	28
ø63	82	M12×1.75	ø36	10	22	65	124	□69	150	13	13	30
ø80	95	M14×2	ø45	15	25	87	154	□86	185	17	17	35

- Notes) • When you use the cylinder with lock nut, we recommend you change A dimension for parenthesis one.
 • The lock nut needs to be ordered separately.
 • 20mm and 25mm bore size of Cutting Fluid Proof Type are not available.
 • Allowance of MM is f8.

160S-1/THS16 Bore CAD/DATA is available.



SD

General purpose type	160S-1R	6	SD	Bore	N	Stroke	T	Switch symbol	Quantity of Switch
Cutting fluid proof type	160SW-1R	6	SD	Bore	N	Stroke	T	Switch symbol	Quantity of Switch

□: Female thread
 □: Male thread

• Bore $\phi 32 - \phi 80$

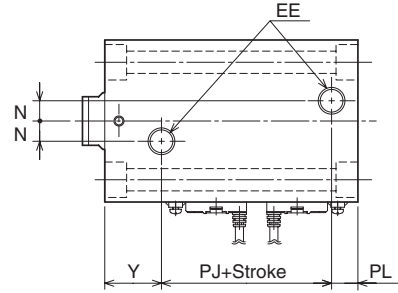
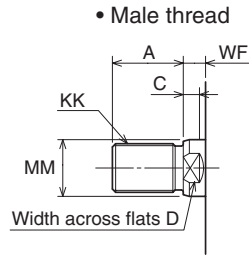
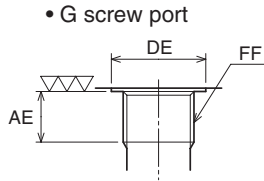

Cord extended to rear
 AX type

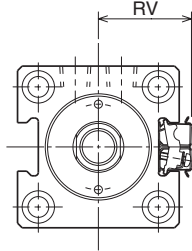

Cord extended to top
 AZ type

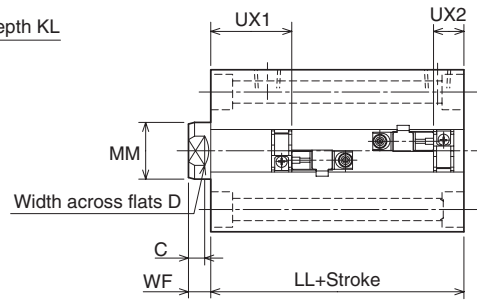
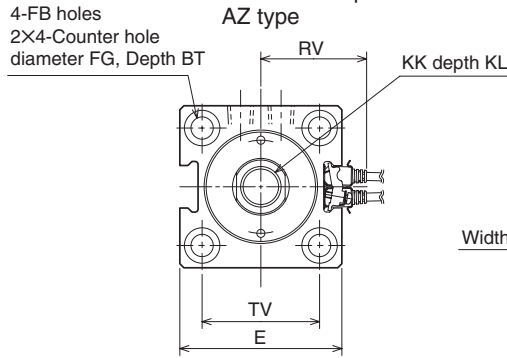

16MPa Compact Design Hydraulic Cylinder Double Acting Single-rod/Switch set

160S-1

Unit: mm

General purpose type

Dimension Table

Symbol Bore	A	AE	BT	C	D	DE	E	EE	FB	FF	FG	KK		KL
												Female thread	Male thread	
ø32	25(40)	8	6.5	7	14	ø17.2	□62	Rc1/4	ø6.6	G1/8	ø11	M12×1.75	M16×1.5	15
ø40	30(45)	8	8.6	7	19	ø17.2	□70	Rc1/4	ø9	G1/8	ø14	M16×2	M20×1.5	20
ø50	35(50)	12	10.8	8	24	ø21.5	□80	Rc1/4	ø11	G1/4	ø17.5	M20×2.5	M24×1.5	24
ø63	45(60)	12	13	9	30	ø21.5	□94	Rc1/4	ø14	G1/4	ø20	M27×3	M30×1.5	33
ø80	60(80)	12	15.2	14	41	ø21.5	□114	Rc3/8	ø16	G1/4	ø23	M30×3.5	M39×1.5	36

Symbol Bore	LL	MM	N		PJ		PL		RV		TV	UX1	UX2	WF	Y	
															Rc thread	G thread
ø32	54	ø18	10	10	14	14	12	12	37	44	□47	19	17	10	28	28
ø40	55	ø22	10	10	16	16	12	12	41	48	□52	20	17	10	27	27
ø50	60	ø28	10	14	19	13.5	13	18.5	46	53	□58	22	20	11	28	28
ø63	67	ø36	10	16	24	20	13	17	53	60	□69	24	25	13	30	30
ø80	78	ø45	15	19	25	24	18	18	63	70	□86	30	30	17	35	36

- Notes) • When you use the cylinder with lock nut, we recommend you change A dimension for parenthetic one.
 • The lock nut needs to be ordered separately.
 • 20mm and 25mm bore size of Cutting Fluid Proof Type are not available.
 • Allowance of MM is f8.

Cutting fluid proof type

Dimension Table

Bore	RV				RY				UX1			UX2		
	Cord rear wiring		Cord upper wiring		Cord rear wiring		Cord upper wiring		AX205W	WR	WS	AX205W	WR	WS
	AX205W	WR•WS	AZ205W	WR•WS	AX205W	WR•WS	AZ205W	WR•WS	AZ205W			AZ205W		
ø32	37	53	44	53	74	106	88	106	13	11	15	11	12	16
ø40	41	57	48	57	82	114	96	114	14	17	20	11	14	16
ø50	46	62	53	62	92	124	106	124	16	19	21	14	16	20
ø63	54	69	61	69	108	138	122	138	17	20	24	18	21	23
ø80	63	79	70	79	126	158	140	158	22	25	29	22	25	29

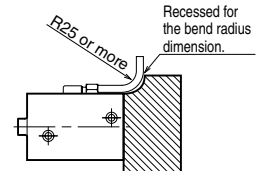

When the switch cannot be attached as shown above, use the other type (cord upper wiring).

- Note) Set the flex tube so that its bend radius becomes R25 or more.
 If the bend radius becomes smaller than this value, the cord may be disconnected.

Switch attachment dimensions

- Cord rear wiring

- Cord upper wiring

AX205W (no contact) WR525 (contact)
 WS235-1 (no contact)

AZ205W (no contact) WR535 (contact)
 WS245-1 (no contact)

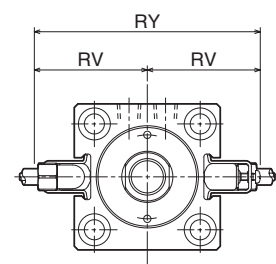
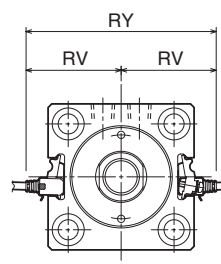
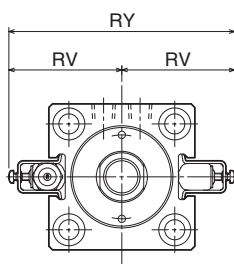
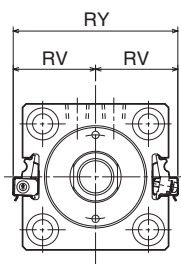

ST General purpose type 160S-1R 6 ST Bore N Stroke T Switch symbol Quantity of Switch (ø32-ø80/Made-to-order)

☐: Female thread
☒: Male thread

over 101 strokes (110, 120, 130, 140, 150, 160, 170, 180, 190, 200)

• Bore ø32 - ø80

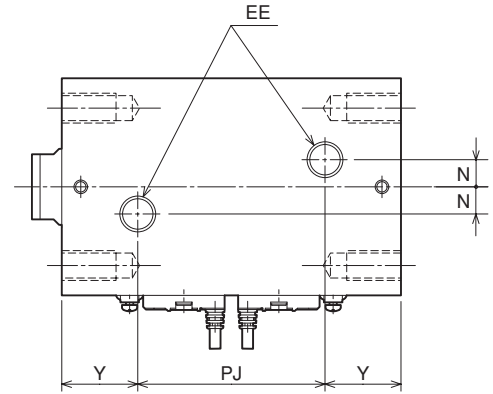
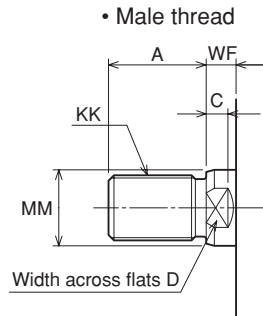

Cord extended to rear
AX type

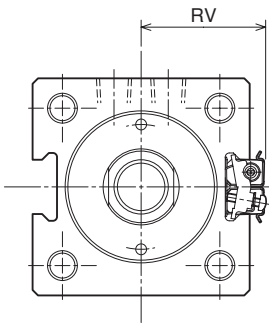

Cord extended to top
AZ type

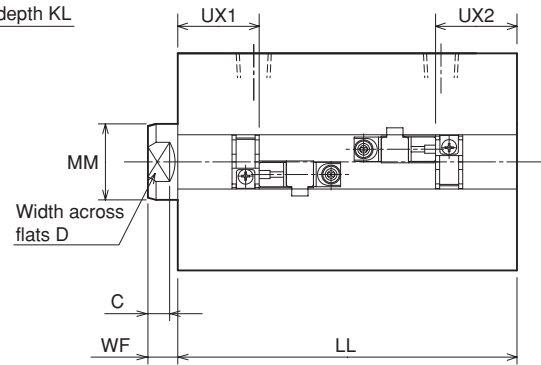
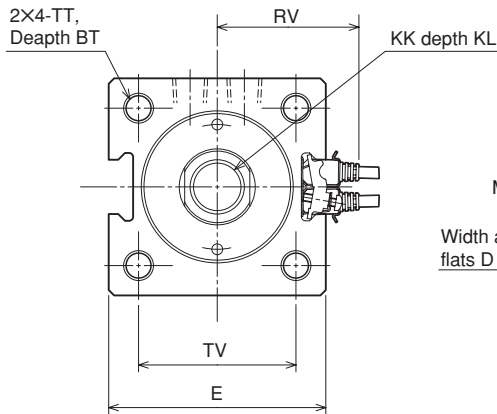

16MPa Compact Design Hydraulic Cylinder Double Acting Single-rod/Switch set

Unit: mm

160S-1

52

Dimension Table

Symbol Bore	A	BT	C	D	E	EE	KK		KL	MM	N	RV		TT	TV	UX1	UX2	WF	Y
							Female thread	Male thread				AX type	AZ type						
							∅32	25(40)				15	7						
∅40	30(45)	20	7	19	□70	Rc1/4	M16 ×2	M20 ×1.5	20	∅22	10	41	48	M8×1.25	□52	30	34	10	27
∅50	35(50)	25	8	24	□80	Rc1/4	M20 ×2.5	M24 ×1.5	24	∅28	10	46	53	M10×1.5	□58	32	35	11	28
∅63	45(60)	30	9	30	□94	Rc1/4	M27 ×3	M30 ×1.5	33	∅36	10	53	60	M12×1.75	□69	34	40	13	30
∅80	60(80)	35	14	41	□114	Rc3/8	M30 ×3.5	M39 ×1.5	36	∅45	15	63	70	M16×2	□86	40	47	17	35

Symbol Stroke Bore	LL										PJ									
	110	120	130	140	150	160	170	180	190	200	110	120	130	140	150	160	170	180	190	200
∅32	192	202	212	222	232	242	252	262	272	282	136	146	156	166	176	186	196	206	216	226
∅40	192	202	212	222	232	242	252	262	272	282	138	148	158	168	178	188	198	208	218	228
∅50	195	205	215	225	235	245	255	265	275	285	139	149	159	169	179	189	199	209	219	229
∅63	202	212	222	232	242	252	262	272	282	292	142	152	162	172	182	192	202	212	222	232
∅80	215	225	235	245	255	265	275	285	295	305	145	155	165	175	185	195	205	215	225	235

- Notes)
- When you use the cylinder with lock nut, we recommend you change A dimension for parenthetic one.
 - The lock nut needs to be ordered separately.
 - Allowance of MM is f8.

LA General purpose type 160S-1R 6 LA Bore N Stroke T Switch symbol Quantity of Switch

□: Female thread
T: Male thread

• Bore $\phi 32 - \phi 63$

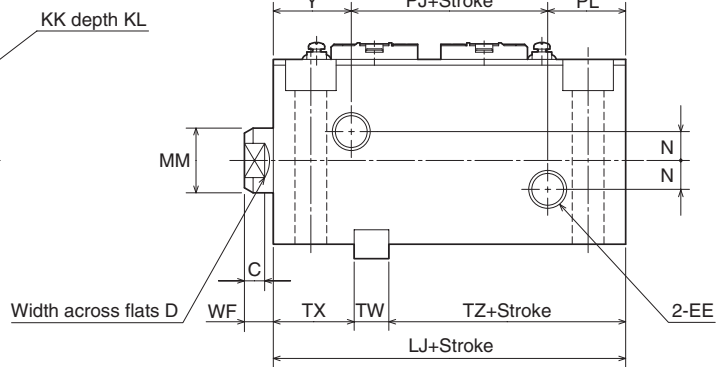
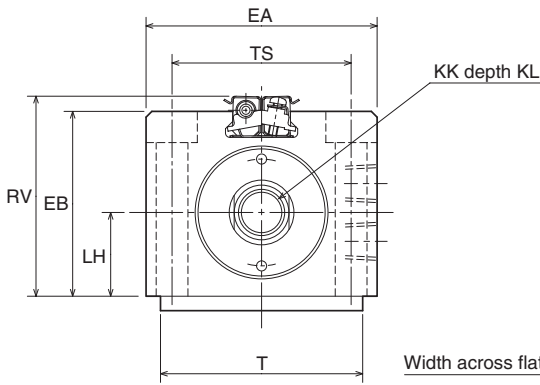
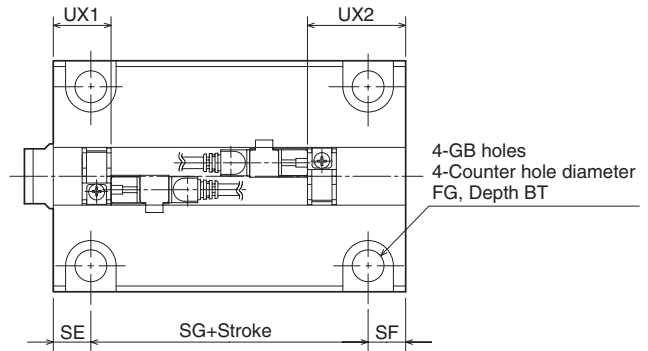
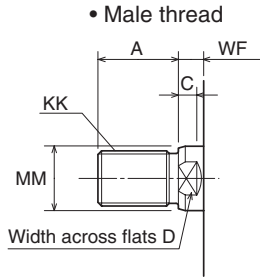

Dimension Table

Symbol Bore	A	BT	C	D	EA	EB	EE	FG	GB	KK		KL	LH	LJ	MM
										Female thread	Male thread				
ø32	25(40)	8.6	7	14	70	56	Rc1/4	ø14	ø9	M12×1.75	M16×1.5	15	25±0.06	72	ø18
ø40	30(45)	10.8	7	19	80	64	Rc1/4	ø17.5	ø11	M16×2	M20×1.5	20	29±0.06	72	ø22
ø50	35(50)	13	8	24	94	74	Rc1/4	ø20	ø14	M20×2.5	M24×1.5	24	34±0.06	75	ø28
ø63	45(60)	15.2	9	30	114	89	Rc1/4	ø23	ø16	M27×3	M30×1.5	33	42±0.06	82	ø36

Symbol Bore	N	PJ	PL	RV	SE	SF	SG	T	TS	TW	TX	TZ	UX1	UX2	WF	Y
ø32	8	16	28	62	13	13	46	63	56	12	28	32	19	35	10	28
ø40	10	18	27	70	13	13	46	70	62	12	28	32	20	34	10	27
ø50	10	15	30	80	13	13	49	80	74	14	29	32	22	35	11	30
ø63	10	18	32	95	15	15	52	100	90	16	31	35	24	40	13	32

- Notes) • When you use the cylinder with lock nut, we recommend you change A dimension for parenthetic one.
 • The lock nut needs to be ordered separately.
 • Allowance of MM is f8.

Recommended Key Way Dimensions

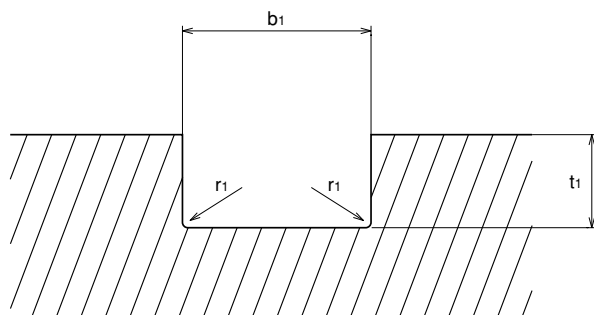

When using a parallel key:

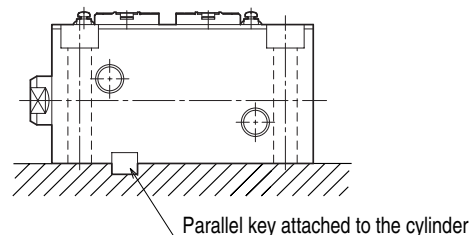

When not using a parallel key:

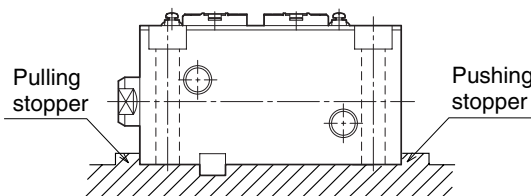

Use the same dimensions for the stopper as the attached parallel key.

Dimension Table

Bore	Key's Nominal Dimensions b × h × l	Key Way Dimensions		
		b ₁	t ₁	r ₁
ø32	12×8×63 (Both rounded)	12 ⁰ _{-0.043}	5 ^{+0.2} ₀	0.25 - 0.40
ø40	12×8×70 (Both rounded)	12 ⁰ _{-0.043}	5 ^{+0.2} ₀	
ø50	14×9×80 (Both rounded)	14 ⁰ _{-0.043}	5.5 ^{+0.2} ₀	
ø63	16×10×100 (Both rounded)	16 ⁰ _{-0.043}	6 ^{+0.2} ₀	

- When using the foot type, use the attached parallel key to install the cylinder, referring to the "Recommended Key Way Dimensions."
- When not using the parallel key, attach the stoppers to the cylinder's front and rear sides toward its stroke direction. If the cylinder is used without using the key or stoppers, a large force is applied to the cylinder's mounting bolts, possibly resulting in the fracturing of the bolts.

160S-1/THS16 Bore

CAD/DATA is available.



LD

General purpose type	160S-1R	6	LD	Bore	N	Stroke	T	Switch symbol	Quantity of Switch
Cutting fluid proof type	160SW-1R	6	LD	Bore	N	Stroke	T	Switch symbol	Quantity of Switch

□: Female thread
 □: Male thread

• Bore $\phi 32 - \phi 80$

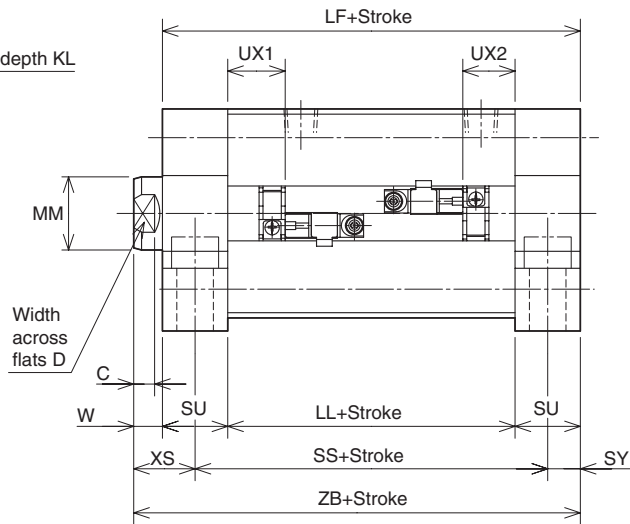
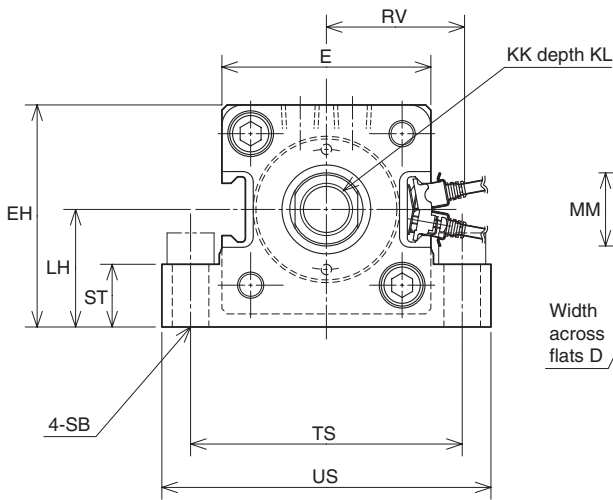
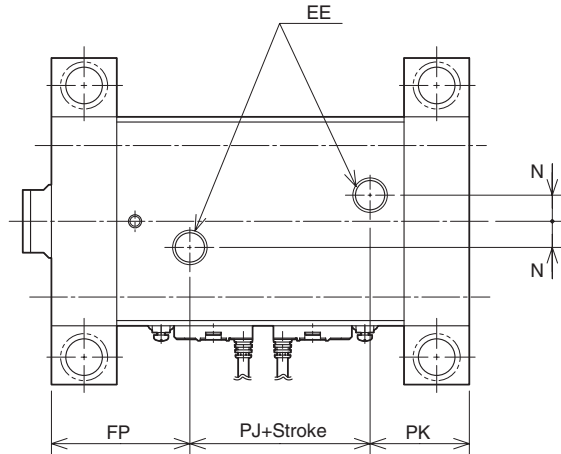
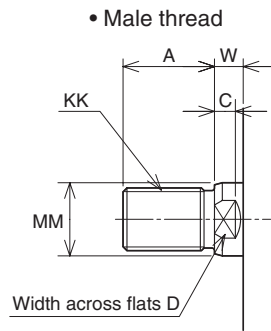

*Please be sure to use the Socket Head Screw when install the cylinder to the contact patch.

16MPa Compact Design Hydraulic Cylinder Double Acting Single-rod/Switch set

Unit: mm

160S-1

General purpose type

Dimension Table

Symbol Bore	A	C	D	E	EE	EH	FP	KK		KL	LF	LH	LL
								Female thread	Male thread				
ø32	25(40)	7	14	□ 62	Rc1/4	66	48	M12×1.75	M16×1.5	15	94	35±0.15	54
ø40	30(45)	7	19	□ 70	Rc1/4	72.5	47	M16×2	M20×1.5	20	95	37.5±0.15	55
ø50	35(50)	8	24	□ 80	Rc1/4	85	53	M20×2.5	M24×1.5	24	110	45±0.15	60
ø63	45(60)	9	30	□ 94	Rc1/4	97	55	M27×3	M30×1.5	33	117	50±0.15	67
ø80	60(80)	14	41	□ 114	Rc3/8	117	65	M30×3.5	M39×1.5	36	138	60±0.25	78

Symbol Bore	MM	N	PJ	PK	RV		SB	SS	ST	SU	SY	TS	US	UX1	UX2	W	XS	ZB
					AX type	AZ type												
ø32	ø18	10	14	32	37	44	9	74	16	20	10	79	94	19	17	10	20	104
ø40	ø22	10	16	32	41	48	11	75	20	20	10	90	108	20	17	10	20	105
ø50	ø28	10	19	38	46	53	14	85	24	25	12.5	104	126	22	20	11	23.5	121
ø63	ø36	10	24	38	53	60	16	92	30	25	12.5	121	146	24	25	13	25.5	130
ø80	ø45	15	25	48	63	70	18	108	35	30	15	144	172	30	30	17	32	155

- Notes) • When you use the cylinder with lock nut, we recommend you change A dimension for parenthetic one.
 • The lock nut needs to be ordered separately.
 • Allowance of MM is f8.

Cutting fluid proof type

Dimension Table

Bore	RV				RY				UX1			UX2		
	Cord rear wiring		Cord upper wiring		Cord rear wiring		Cord upper wiring		AX205W	WR	WS	AX205W	WR	WS
	AX205W	WR•WS	AZ205W	WR•WS	AX205W	WR•WS	AZ205W	WR•WS	AZ205W			AZ205W		
ø32	37	53	44	53	74	106	88	106	13	11	15	11	12	16
ø40	41	57	48	57	82	114	96	114	14	17	20	11	14	16
ø50	46	62	53	62	92	124	106	124	16	19	21	14	16	20
ø63	54	69	61	69	108	138	122	138	17	20	24	18	21	23
ø80	63	79	70	79	126	158	140	158	22	25	29	22	25	29

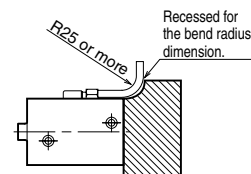

When the switch cannot be attached as shown above, use the other type (cord upper wiring).

- Note) Set the flex tube so that its bend radius becomes R25 or more.
 If the bend radius becomes smaller than this value, the cord may be disconnected.

Switch attachment dimensions

- Cord rear wiring

- Cord upper wiring

AX205W (no contact)

WR525 (contact)
WS235-1 (no contact)

AZ205W (no contact)

WR535 (contact)
WS245-1 (no contact)

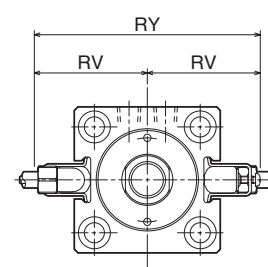
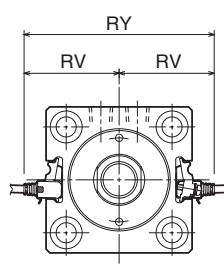
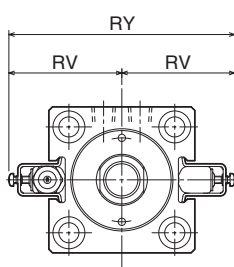
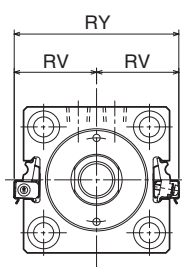

160S-1/THS16 CAD/DATA is available. 

FA

General purpose type	160S-1R	<input type="text" value="6"/>	FA	<input type="text" value="Bore"/>	N	Stroke	<input type="text" value="T"/>	Switch symbol	Quantity of Switch
Cutting fluid proof type	160SW-1R	<input type="text" value="6"/>	FA	<input type="text" value="Bore"/>	N	Stroke	<input type="text" value="T"/>	Switch symbol	Quantity of Switch

: Female thread
 : Male thread

• Bore $\phi 32 - \phi 80$

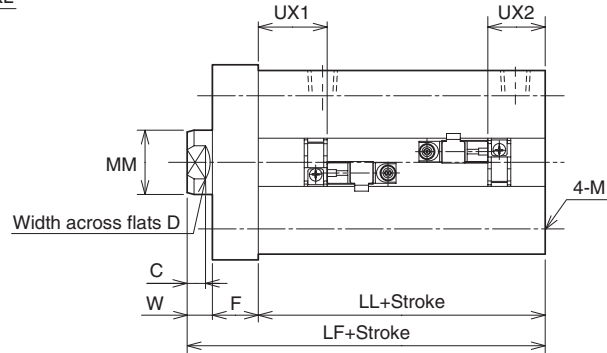
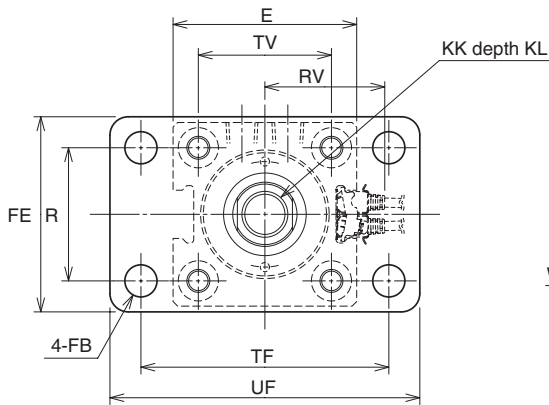
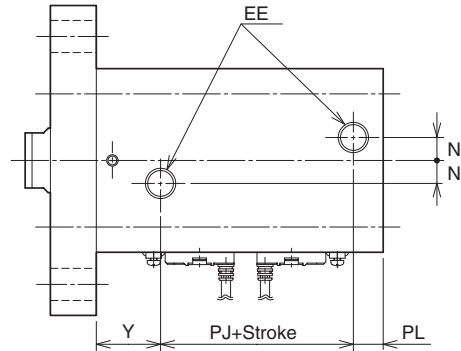
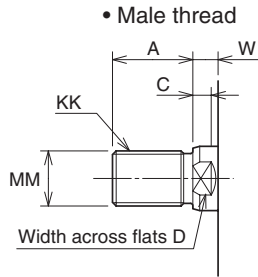

*Please be sure to use the Socket Head Screw when install the cylinder to the contact patch.

16MPa Compact Design Hydraulic Cylinder Double Acting Single-rod/Switch set

Unit: mm

160S-1

General purpose type

Dimension Table

Symbol Bore	A	C	D	E	EE	F	FB	FE	KK		KL	LF	LL	M
									Female thread	Male thread				
ø32	25(40)	7	14	□62	Rc1/4	15	ø6.6	62	M12 ×1.75	M16 ×1.5	15	79	54	M6 ×1
ø40	30(45)	7	19	□70	Rc1/4	20	ø11	70	M16 ×2	M20 ×1.5	20	85	55	M8 ×1.25
ø50	35(50)	8	24	□80	Rc1/4	20	ø14	85	M20 ×2.5	M24 ×1.5	24	91	60	M10 ×1.5
ø63	45(60)	9	30	□94	Rc1/4	20	ø14	98	M27 ×3	M30 ×1.5	33	100	67	M12 ×1.75
ø80	60(80)	14	41	□114	Rc3/8	25	ø18	118	M30 ×3.5	M39 ×1.5	36	120	78	M14 ×2

Symbol Bore	MM	N	PJ	PL	R	RV		TF	TV	UF	UX1	UX2	W	Y
						AX type	AZ type							
ø32	ø18	10	14	12	40	37	44	80	□47	95	19	17	10	28
ø40	ø22	10	16	12	46	41	48	96	□52	118	20	17	10	27
ø50	ø28	10	19	13	58	46	53	108	□58	135	22	20	11	28
ø63	ø36	10	24	13	65	53	60	124	□69	150	24	25	13	30
ø80	ø45	15	25	18	87	63	70	154	□86	185	30	30	17	35

- Notes) • When you use the cylinder with lock nut, we recommend you change A dimension for parenthetic one.
 • The lock nut needs to be ordered separately.
 • 20mm and 25mm bore size of Cutting Fluid Proof Type are not available.
 • Allowance of MM is f8.

Cutting fluid proof type

Dimension Table

Bore	RV				RY				UX1			UX2		
	Cord rear wiring		Cord upper wiring		Cord rear wiring		Cord upper wiring		AX205W	WR	WS	AX205W	WR	WS
	AX205W	WR•WS	AZ205W	WR•WS	AX205W	WR•WS	AZ205W	WR•WS	AZ205W			AZ205W		
ø32	37	53	44	53	74	106	88	106	13	11	15	11	12	16
ø40	41	57	48	57	82	114	96	114	14	17	20	11	14	16
ø50	46	62	53	62	92	124	106	124	16	19	21	14	16	20
ø63	54	69	61	69	108	138	122	138	17	20	24	18	21	23
ø80	63	79	70	79	126	158	140	158	22	25	29	22	25	29

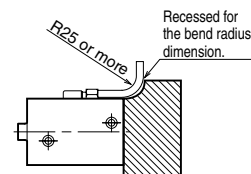

When the switch cannot be attached as shown above, use the other type (cord upper wiring).

- Note) Set the flex tube so that its bend radius becomes R25 or more.
 If the bend radius becomes smaller than this value, the cord may be disconnected.

Switch attachment dimensions

- Cord rear wiring

- Cord upper wiring

AX205W (no contact)

WR525 (contact)
WS235-1 (no contact)

AZ205W (no contact)

WR535 (contact)
WS245-1 (no contact)

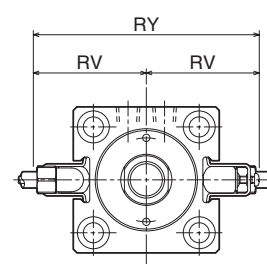
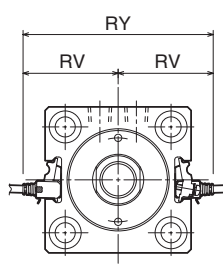
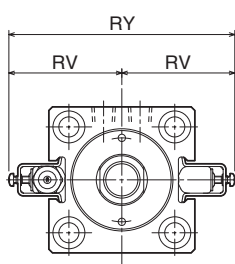
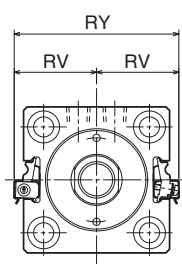

CAD/DATA
is available.



160S-1/THS16 Bore

FB

General purpose type	160S-1R	6	FB	Bore	N	Stroke	T	Switch symbol	Quantity of Switch
Cutting fluid proof type	160SW-1R	6	FB	Bore	N	Stroke	T	Switch symbol	Quantity of Switch

□: Female thread
T: Male thread

• Bore $\phi 32 - \phi 80$

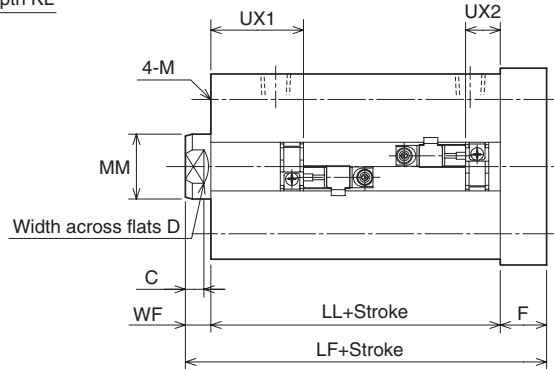
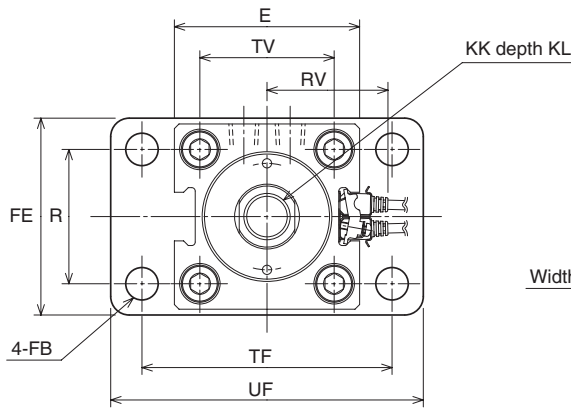
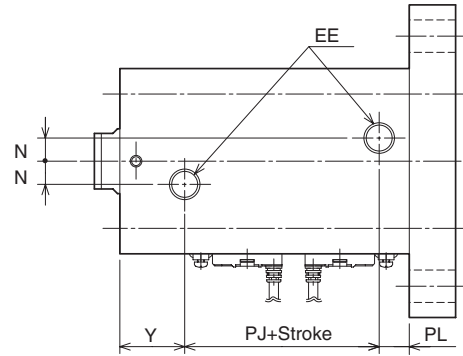
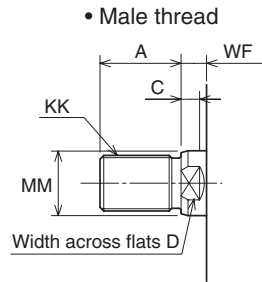

16MPa Compact Design Hydraulic Cylinder Double Acting Single-rod/Switch set

Unit: mm

160S-1

General purpose type

Dimension Table

Symbol Bore	A	C	D	E	EE	F	FB	FE	KK		KL	LF	LL	M
									Female thread	Male thread				
ø32	25(40)	7	14	□62	Rc1/4	15	ø6.6	62	M12×1.75	M16×1.5	15	79	54	M6×1
ø40	30(45)	7	19	□70	Rc1/4	20	ø11	70	M16×2	M20×1.5	20	85	55	M8×1.25
ø50	35(50)	8	24	□80	Rc1/4	20	ø14	85	M20×2.5	M24×1.5	24	91	60	M10×1.5
ø63	45(60)	9	30	□94	Rc1/4	20	ø14	98	M27×3	M30×1.5	33	100	67	M12×1.75
ø80	60(80)	14	41	□114	Rc3/8	25	ø18	118	M30×3.5	M39×1.5	36	120	78	M14×2

Symbol Bore	MM	N	PJ	PL	R	RV		TF	TV	UF	UX1	UX2	WF	Y
						AX type	AZ type							
ø32	ø18	10	14	12	40	37	44	80	□47	95	19	17	10	28
ø40	ø22	10	16	12	46	41	48	96	□52	118	20	17	10	27
ø50	ø28	10	19	13	58	46	53	108	□58	135	22	20	11	28
ø63	ø36	10	24	13	65	53	60	124	□69	150	24	25	13	30
ø80	ø45	15	25	18	87	63	70	154	□86	185	30	30	17	35

- Notes) • When you use the cylinder with lock nut, we recommend you change A dimension for parenthetic one.
 • The lock nut needs to be ordered separately.
 • 20mm and 25mm bore size of Cutting Fluid Proof Type are not available.
 • Allowance of MM is f8.

Cutting fluid proof type

Dimension Table

Bore	RV				RY				UX1			UX2		
	Cord rear wiring		Cord upper wiring		Cord rear wiring		Cord upper wiring		AX205W	WR	WS	AX205W	WR	WS
	AX205W	WR•WS	AZ205W	WR•WS	AX205W	WR•WS	AZ205W	WR•WS	AZ205W			AZ205W		
ø32	37	53	44	53	74	106	88	106	13	11	15	11	12	16
ø40	41	57	48	57	82	114	96	114	14	17	20	11	14	16
ø50	46	62	53	62	92	124	106	124	16	19	21	14	16	20
ø63	54	69	61	69	108	138	122	138	17	20	24	18	21	23
ø80	63	79	70	79	126	158	140	158	22	25	29	22	25	29

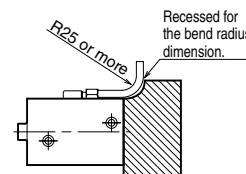

When the switch cannot be attached as shown above, use the other type (cord upper wiring).

- Note) Set the flex tube so that its bend radius becomes R25 or more.
 If the bend radius becomes smaller than this value, the cord may be disconnected.

Switch attachment dimensions

- Cord rear wiring

- Cord upper wiring

AX205W (no contact)

WR525 (contact)
WS235-1 (no contact)

AZ205W(no contact)

WR535 (contact)
WS245-1 (no contact)

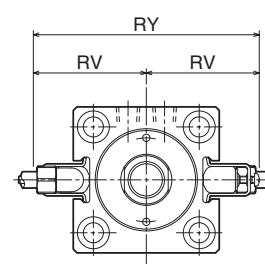
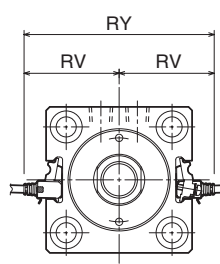
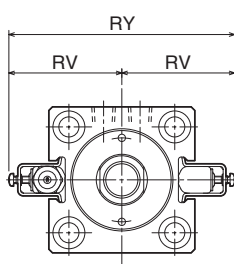
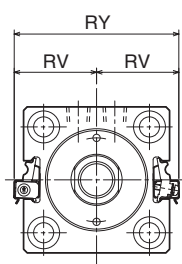

160S-1/THS16 Bore

CAD/DATA is available.



SD

General purpose type	160S-1RD	6	SD	Bore	N	Stroke	T	Switch symbol	Quantity of Switch
Cutting fluid proof type	160SW-1RD	6	SD	Bore	N	Stroke	T	Switch symbol	Quantity of Switch

□: Female thread
 □: Male thread

• Bore $\phi 32 - \phi 80$

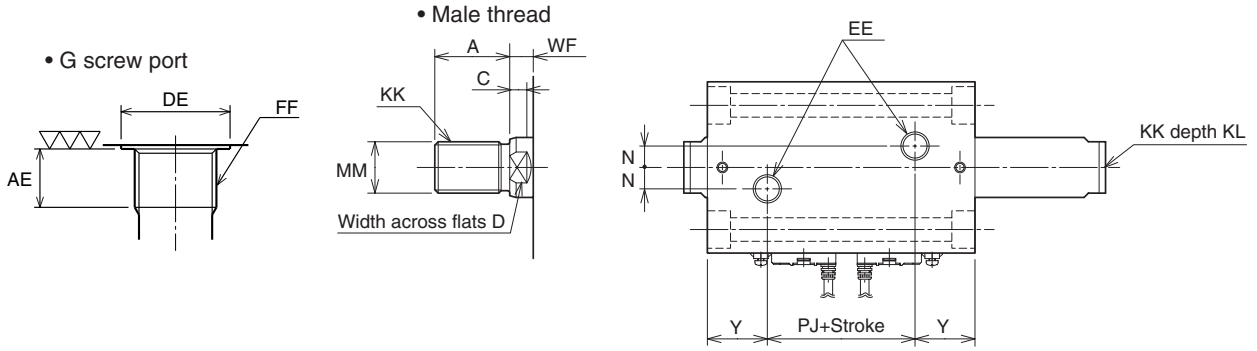

Cord extended to rear
AX type

Cord extended to top
AZ type

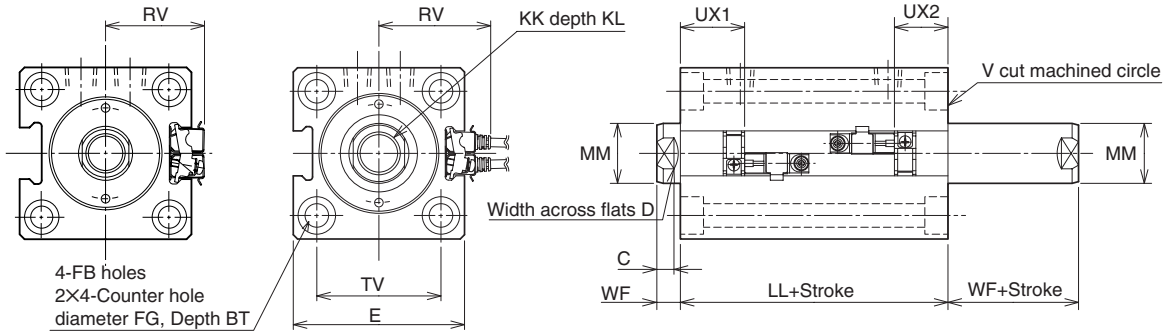

16MPa Compact Design Hydraulic Cylinder Double Acting Double-rod/Switch set

Unit: mm

160S-1

General purpose type

Dimension Table

Symbol Bore	A	AE	BT	C	D	DE	E	EE	FB	FF	FG	KK		KL
												Female thread	Male thread	
ø32	25(40)	8	6.5	7	14	ø17.2	□62	Rc1/4	ø6.6	G1/8	ø11	M12×1.75	M16×1.5	15
ø40	30(45)	8	8.6	7	19	ø17.2	□70	Rc1/4	ø9	G1/8	ø14	M16×2	M20×1.5	20
ø50	35(50)	12	10.8	8	24	ø21.5	□80	Rc1/4	ø11	G1/4	ø17.5	M20×2.5	M24×1.5	24
ø63	45(60)	12	13	9	30	ø21.5	□94	Rc1/4	ø14	G1/4	ø20	M27×3	M30×1.5	33
ø80	60(80)	12	15.2	14	41	ø21.5	□114	Rc3/8	ø16	G1/4	ø23	M30×3.5	M39×1.5	36

Symbol Bore	LL	MM	N		PJ		RV		TV	UX1	UX2	WF	Y	
												Rc thread	G thread	
ø32	72	ø18	10	10	16	14	37	44	□47	19	35	10	28	28
ø40	72	ø22	10	10	18	16	41	48	□52	20	34	10	27	27
ø50	75	ø28	10	14	19	13.5	46	53	□58	22	35	11	28	28
ø63	82	ø36	10	16	22	20	53	60	□69	24	40	13	30	30
ø80	95	ø45	15	19	25	24	63	70	□86	30	47	17	35	36

- Notes) • When you use the cylinder with lock nut, we recommend you change A dimension for parenthetic one.
 • The lock nut needs to be ordered separately.
 • Allowance of MM is f8.

Cutting fluid proof type

Dimension Table

Bore	RV				RY				UX1			UX2		
	Cord rear wiring		Cord upper wiring		Cord rear wiring		Cord upper wiring		AX205W	WR	WS	AX205W	WR	WS
	AX205W	WR•WS	AZ205W	WR•WS	AX205W	WR•WS	AZ205W	WR•WS	AZ205W			AZ205W		
ø32	37	53	44	53	74	106	88	106	13	11	15	11	28	32
ø40	41	57	48	57	82	114	96	114	14	17	20	11	33	36
ø50	46	62	53	62	92	124	106	124	16	19	21	14	35	37
ø63	54	69	61	69	108	138	122	138	17	20	24	18	36	40
ø80	63	79	70	79	126	158	140	158	22	25	29	22	43	47

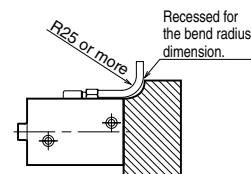

When the switch cannot be attached as shown above, use the other type (cord upper wiring).

- Note) Set the flex tube so that its bend radius becomes R25 or more.
 If the bend radius becomes smaller than this value, the cord may be disconnected.

Switch attachment dimensions

- Cord rear wiring

- Cord upper wiring

AX205W (no contact)

WS235-1 (no contact)

AZ205W (no contact)

WS245-1 (no contact)

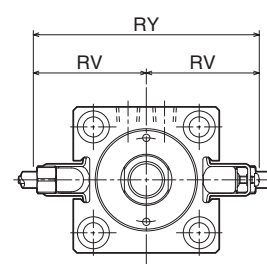
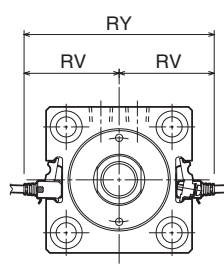
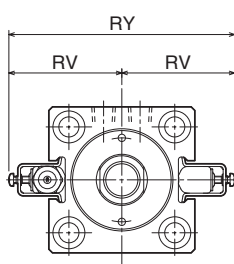
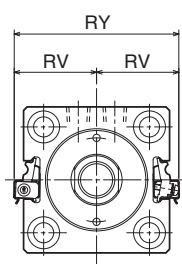

160S-1/THS16 Bore

CAD/DATA is available.



LD

General purpose type	160S-1RD	6	LD	Bore	N	Stroke	T	Switch symbol	Quantity of Switch
Cutting fluid proof type	160SW-1RD	6	LD	Bore	N	Stroke	T	Switch symbol	Quantity of Switch

□: Female thread
 T: Male thread

• Bore $\phi 32 - \phi 80$

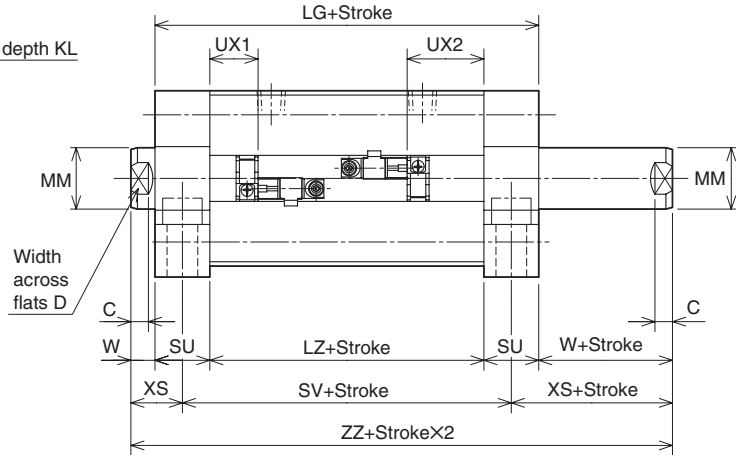
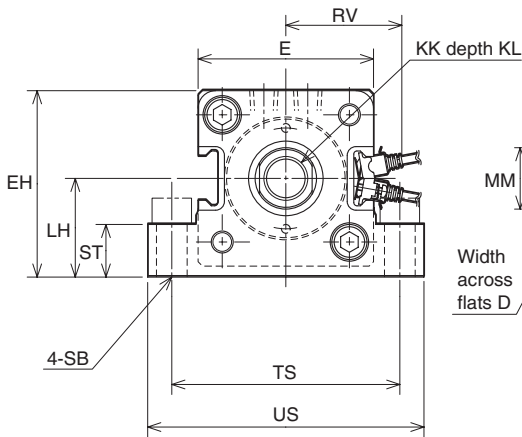
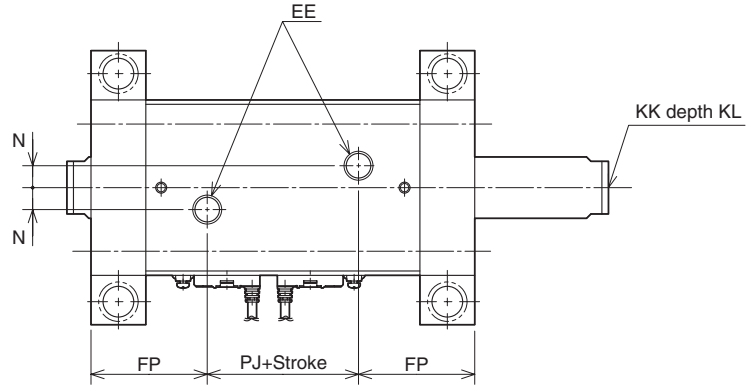
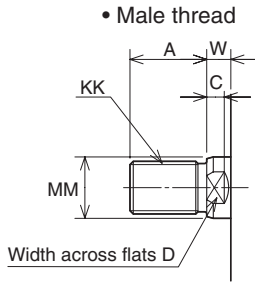

*Please be sure to use the Socket Head Screw when install the cylinder to the contact patch.

16MPa Compact Design Hydraulic Cylinder Double Acting Double-rod/Switch set

Unit: mm

160S-1

General purpose type

Dimension Table

Symbol Bore	A	C	D	E	EE	EH	FP	KK		KL	LG	LH	LZ
								Female thread	Male thread				
ø32	25(40)	7	14	□62	Rc1/4	66	48	M12×1.75	M16×1.5	15	112	35±0.15	72
ø40	30(45)	7	19	□70	Rc1/4	72.5	47	M16×2	M20×1.5	20	112	37.5±0.15	72
ø50	35(50)	8	24	□80	Rc1/4	85	53	M20×2.5	M24×1.5	24	125	45±0.15	75
ø63	45(60)	9	30	□94	Rc1/4	97	55	M27×3	M30×1.5	33	132	50±0.15	82
ø80	60(80)	14	41	□114	Rc3/8	117	65	M30×3.5	M39×1.5	36	155	60±0.25	95

Symbol Bore	MM	N	PJ	RV		SB	ST	SU	SV	TS	US	UX1	UX2	W	XS	ZZ
				AX type	AZ type											
ø32	ø18	10	16	37	44	9	16	20	92	79	94	19	35	10	20	132
ø40	ø22	10	18	41	48	11	20	20	92	90	108	20	34	10	20	132
ø50	ø28	10	19	46	53	14	24	25	100	104	126	22	35	11	23.5	147
ø63	ø36	10	22	53	60	16	30	25	107	121	146	24	40	13	25.5	158
ø80	ø45	15	25	63	70	18	35	30	125	144	172	30	47	17	32	189

- Notes) • When you use the cylinder with lock nut, we recommend you change A dimension for parenthesis one.
 • The lock nut needs to be ordered separately.
 • Allowance of MM is f8.

Cutting fluid proof type

Dimension Table

Bore	RV				RY				UX1			UX2		
	Cord rear wiring		Cord upper wiring		Cord rear wiring		Cord upper wiring		AX205W	WR	WS	AX205W	WR	WS
	AX205W	WR•WS	AZ205W	WR•WS	AX205W	WR•WS	AZ205W	WR•WS	AZ205W			AZ205W		
ø32	37	53	44	53	74	106	88	106	13	11	15	11	28	32
ø40	41	57	48	57	82	114	96	114	14	17	20	11	33	36
ø50	46	62	53	62	92	124	106	124	16	19	21	14	35	37
ø63	54	69	61	69	108	138	122	138	17	20	24	18	36	40
ø80	63	79	70	79	126	158	140	158	22	25	29	22	43	47

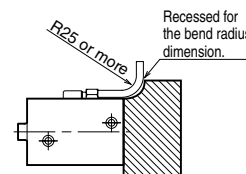

When the switch cannot be attached as shown above, use the other type (cord upper wiring).

- Note) Set the flex tube so that its bend radius becomes R25 or more.
 If the bend radius becomes smaller than this value, the cord may be disconnected.

Switch attachment dimensions

- Cord rear wiring

- Cord upper wiring

AX205W (no contact)

WS235-1 (no contact)

AZ205W (no contact)

WS245-1 (no contact)

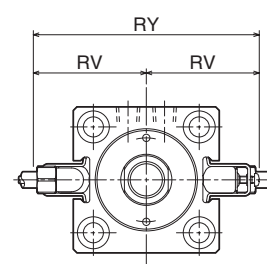
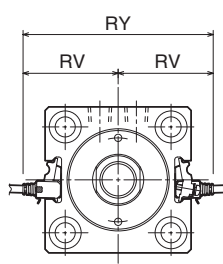
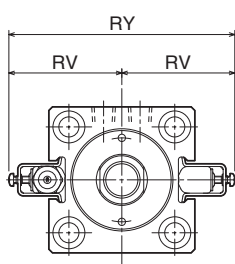
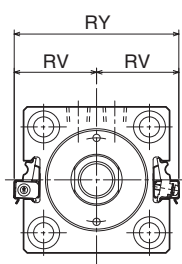

CAD/DATA
is available.



160S-1/THS16 Bore

FA

General purpose type	160S-1RD	6	FA	Bore	N	Stroke	T	Switch symbol	Quantity of Switch
Cutting fluid proof type	160SW-1RD	6	FA	Bore	N	Stroke	T	Switch symbol	Quantity of Switch

□: Female thread
 □: Male thread

• Bore $\phi 32 - \phi 80$

• Male thread

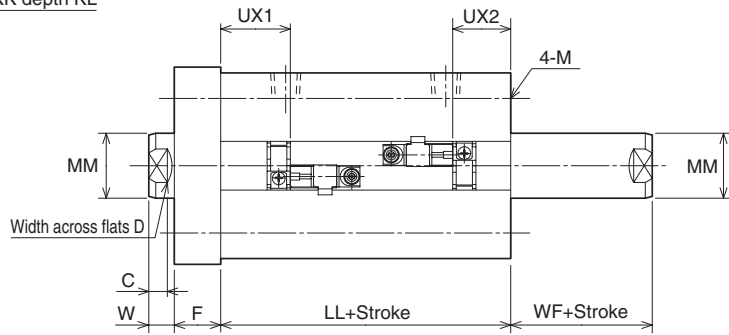
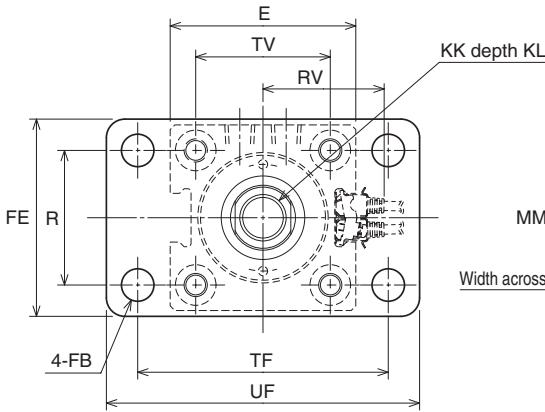
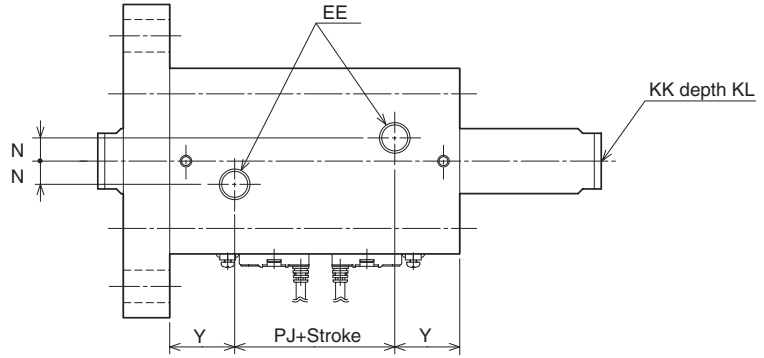
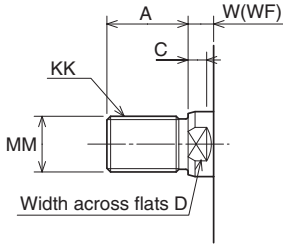

*Please be sure to use the Socket Head Screw when install the cylinder to the contact patch.

16MPa Compact Design Hydraulic Cylinder Double Acting Single-rod/Switch set

Unit: mm

160S-1

General purpose type

Dimension Table

Symbol Bore	A	C	D	E	EE	F	FB	FE	KK		KL	LL
									Female thread	Male thread		
φ32	25(40)	7	14	□62	Rc1/4	15	ø6.6	62	M12×1.75	M16×1.5	15	72
φ40	30(45)	7	19	□70	Rc1/4	20	ø11	70	M16×2	M20×1.5	20	72
φ50	35(50)	8	24	□80	Rc1/4	20	ø14	85	M20×2.5	M24×1.5	24	75
φ63	45(60)	9	30	□94	Rc1/4	20	ø14	98	M27×3	M30×1.5	33	82
φ80	60(80)	14	41	□114	Rc3/8	25	ø18	118	M30×3.5	M39×1.5	36	95

Symbol Bore	M	MM	N	PJ	R	RV		TF	TV	UF	UX1	UX2	W	WF	Y
						AX type	AZ type								
φ32	M6 ×1	ø18	10	16	40	37	44	80	□47	95	19	35	10	10	28
φ40	M8 ×1.25	ø22	10	18	46	41	48	96	□52	118	20	34	10	10	27
φ50	M10 ×1.5	ø28	10	19	58	46	53	108	□58	135	22	35	11	11	28
φ63	M12 ×1.75	ø36	10	22	65	53	60	124	□69	150	24	40	13	13	30
φ80	M14 ×2	ø45	15	25	87	63	70	154	□86	185	30	47	17	17	35

- Notes) • When you use the cylinder with lock nut, we recommend you change A dimension for parenthetic one.
 • The lock nut needs to be ordered separately.
 • Allowance of MM is f8.

Cutting fluid proof type

Dimension Table

Bore	RV				RY				UX1			UX2		
	Cord rear wiring		Cord upper wiring		Cord rear wiring		Cord upper wiring		AX205W	WR	WS	AX205W	WR	WS
	AX205W	WR*WS	AZ205W	WR*WS	AX205W	WR*WS	AZ205W	WR*WS	AZ205W			AZ205W		
φ32	37	53	44	53	74	106	88	106	13	11	15	11	28	32
φ40	41	57	48	57	82	114	96	114	14	17	20	11	33	36
φ50	46	62	53	62	92	124	106	124	16	19	21	14	35	37
φ63	54	69	61	69	108	138	122	138	17	20	24	18	36	40
φ80	63	79	70	79	126	158	140	158	22	25	29	22	43	47

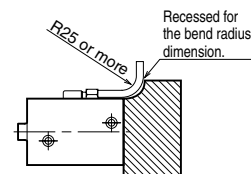

When the switch cannot be attached as shown above, use the other type (cord upper wiring).

- Note) Set the flex tube so that its bend radius becomes R25 or more.
 If the bend radius becomes smaller than this value, the cord may be disconnected.

Switch attachment dimensions

- Cord rear wiring

- Cord upper wiring

AX205W (no contact)

WR525 (contact)
WS235-1 (no contact)

AZ205W (no contact)

WR535 (contact)
WS245-1 (no contact)

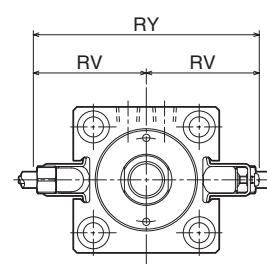
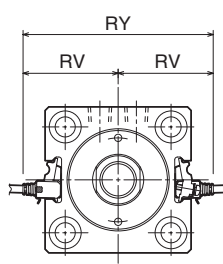
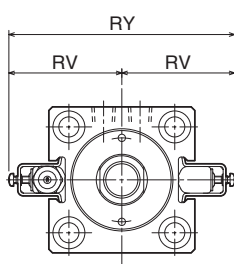
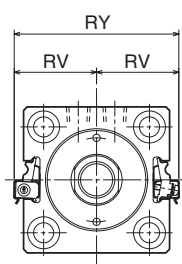

Special specification at the rod end

- You can easily order following categorized items using the Semi-standard symbols and dimensional parameters.

(No need to specify dimensional parameters if you would apply the basic dimensions.)

How to order

Series Model number - X

Semi-standard symbols Dimensional parameters

Parameter KM and KP need to be specified as a pair.

ex. **A83**

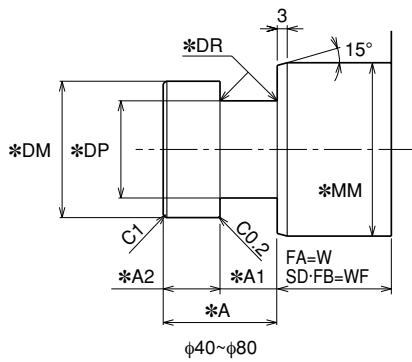

Note) Only WF dimension can be changed at A82 and A83 special rod end shape. If you would like to change other.

- A83, bore:40mm, WF:60mm 160S-1 6SD40N50T-X A83 WF-60

A51

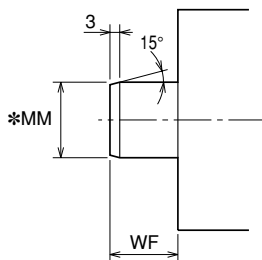

Basic Dimension Table

Bore	*MM	WF
ø20	ø12	8
ø25	ø14	8
ø32	ø18	10
ø40	ø22	10
ø50	ø28	11
ø63	ø36	13
ø80	ø45	17

A00 (T)

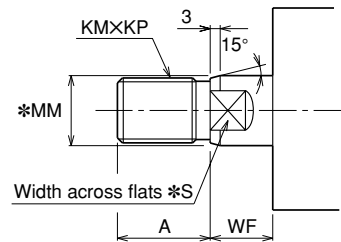

Basic Dimension Table (Standard Dimensions)

Bore	A	KM	KP	*MM	*S	WF
ø20	15	10	1.25	ø12	10	8
ø25	18	12	1.25	ø14	12	8
ø32	25	16	1.5	ø18	14	10
ø40	30	20	1.5	ø22	19	10
ø50	35	24	1.5	ø28	24	11
ø63	45	30	1.5	ø36	30	13
ø80	60	39	1.5	ø45	41	17

A53

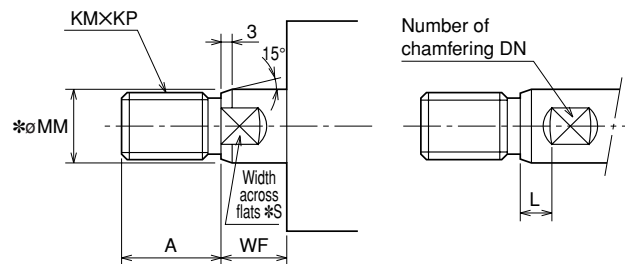

Note) Lengthen WF dimension by combining with L dimension.

Basic Dimension Table

Bore	A	DN	KM	KP	L	*MM	*S	WF
ø20	15	2	10	1.25	0	ø12	10	8
ø25	18	2	12	1.25	0	ø14	12	8
ø32	25	2	16	1.5	0	ø18	14	10
ø40	30	2	20	1.5	0	ø22	19	10
ø50	35	2	24	1.5	0	ø28	24	11
ø63	45	2	30	1.5	0	ø36	30	13
ø80	60	2	39	1.5	0	ø45	41	17

Use this type when the width across flats S of the A00 are required to be moved.

- Dimensions indicated by *Mark are fixed as our semi-standard.
- You are requested to consult us if you would like to change fixed dimensions.

A54

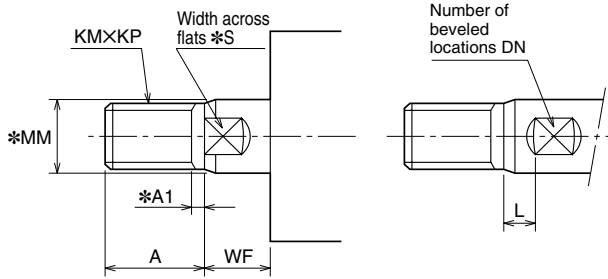

Basic Dimension Table

Bore	A	*A1	DN	KM	KP	L	*MM	*S	WF
ø20	15	4	2	10	1.25	0	ø12	10	8
ø25	18	4	2	12	1.25	0	ø14	12	8
ø32	25	4	2	16	1.5	0	ø18	14	10
ø40	30	4	2	20	1.5	0	ø22	19	10
ø50	35	4	2	24	1.5	0	ø28	24	11
ø63	45	4	2	30	1.5	0	ø36	30	13
ø80	60	4	2	39	1.5	0	ø45	41	17

A81

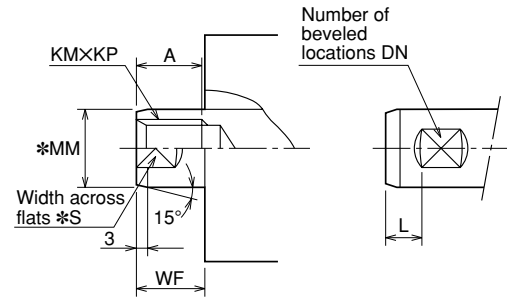

Basic Dimension Table

Bore	A	DN	KM	KP	L	*MM	*S	WF
ø20	10	2	8	1.25	0	ø12	10	8
ø25	12	2	10	1.5	0	ø14	12	8
ø32	15	2	12	1.75	0	ø18	14	10
ø40	20	2	16	2	0	ø22	19	10
ø50	24	2	20	2.5	0	ø28	24	11
ø63	33	2	27	3	0	ø36	30	13
ø80	36	2	30	3.5	0	ø45	41	17

A82

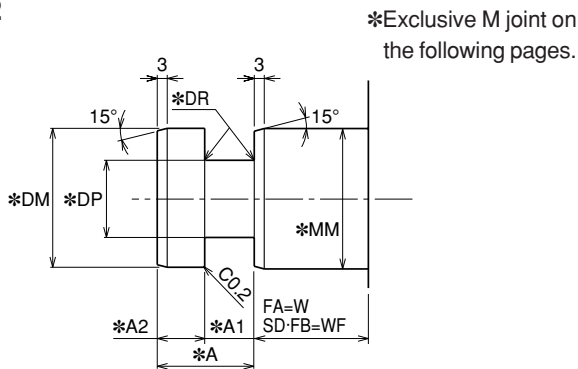

Basic Dimension Table (Standard dimension)

Bore	*A	*A1 ^{+0.5} / _{+0.3}	*A2 ^{-0.2} / _{-0.3}	*DM	*DP ^{-0.2} / _{-0.3}	*DR	*MM	W		WF
								FA type	SD=FB type	
ø20	25	12.5	12.5	ø12	ø8	0.5	ø12	20	20	20
ø25	25	12.5	12.5	ø14	ø10	0.5	ø14	20	20	20
ø32	25	12.5	12.5	ø18	ø13	1.0	ø18	30	30	30
ø40	25	12.5	12.5	ø22	ø16	1.5	ø22	35	35	35
ø50	25	12.5	12.5	ø28	ø21	1.5	ø28	35	35	35
ø63	30	15	15	ø36	ø26	2.0	ø36	40	40	40
ø80	30	15	15	ø45	ø31	2.0	ø45	45	45	45

A83

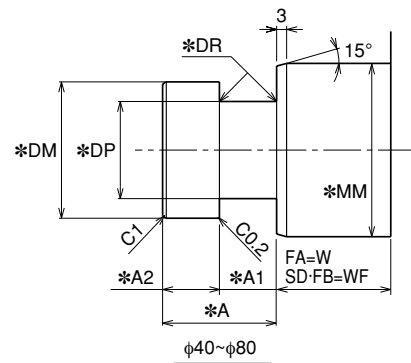

Basic Dimension Table (Standard dimension)

Bore	*A	*A1 ^{+0.5} / _{+0.3}	*A2 ^{-0.2} / _{-0.3}	*DM ^{-0.1} / _{-0.4}	*DP ^{-0.2} / _{-0.3}	*DR	*MM	W		WF
								FA type	SD=FB type	
ø40	25	12.5	12.5	ø18	ø13	1.0	ø22	35	35	35
ø50	25	12.5	12.5	ø22	ø16	1.5	ø28	35	35	35
ø63	25	12.5	12.5	ø28	ø21	1.5	ø36	40	40	40
ø80	30	15	15	ø36	ø26	2.0	ø45	45	45	45

- Dimensions indicated by *Mark are fixed as our semi-standard.
- You are requested to consult us if you would like to change fixed dimensions.

Separate flange joint : Only for A82 rod end style

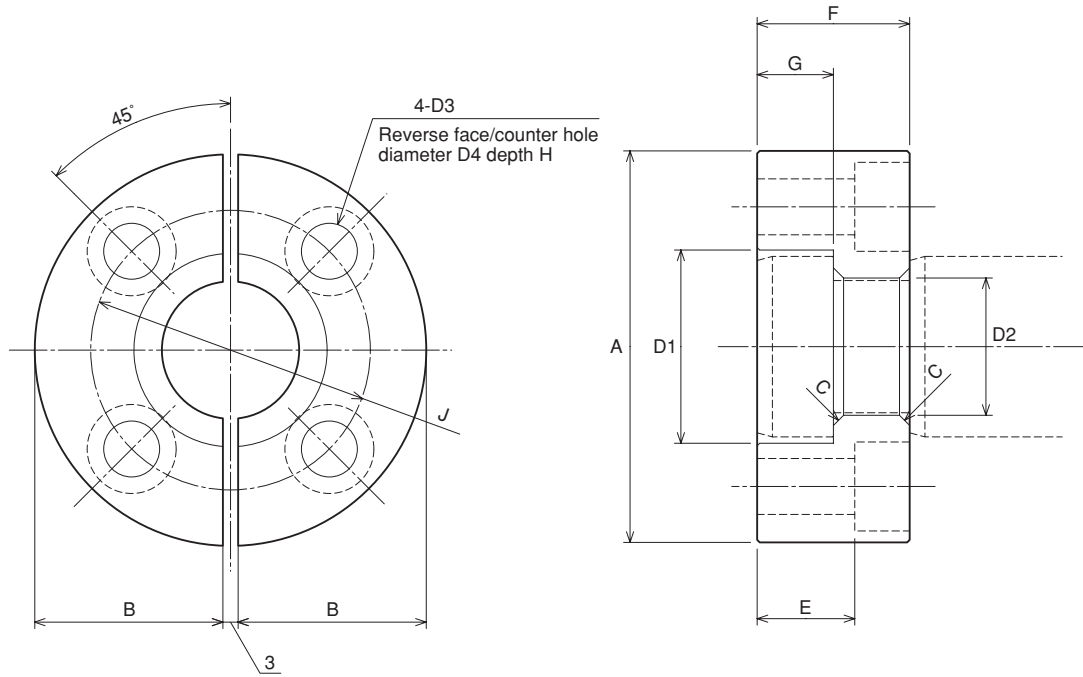

- Need additional order for this item. Part No.: RMH-(bore(mm))

Dimension Table

Symbol Bore	Parts code	A	B	C	D1	D2	D3	D4	E	F	G	H	J
ø20	RMH-12	ø44	20.5	0.5	ø13	ø8.5	ø5.5	ø9.5	19.6	25	12.5	5.4	ø29
ø25	RMH-14	ø46	21.5	0.5	ø15	ø10.5	ø5.5	ø9.5	19.6	25	12.5	5.4	ø31
ø32	RMH-18	ø49	23	1	ø19	ø13.5	ø6.6	ø11	18.5	25	12.5	6.5	ø34
ø40	RMH-22	ø57	27	1.5	ø23	ø16.5	ø9	ø14	16.4	25	12.5	8.6	ø40
ø50	RMH-28	ø71	34	1.5	ø29	ø21.5	ø11	ø17.5	14.2	25	12.5	10.8	ø50
ø63	RMH-36	ø77	37	2	ø38	ø27	ø11	ø17.5	19.2	30	15	10.8	ø55
ø80	RMH-45	ø100	48.5	2	ø48	ø33	ø14	ø20	17	30	15	13	ø76