

TAIYO

PNEUMATIC EQUIPMENT

COMPACT AIR CYLINDER 10S^{series}-1

BASIC CYLINDER

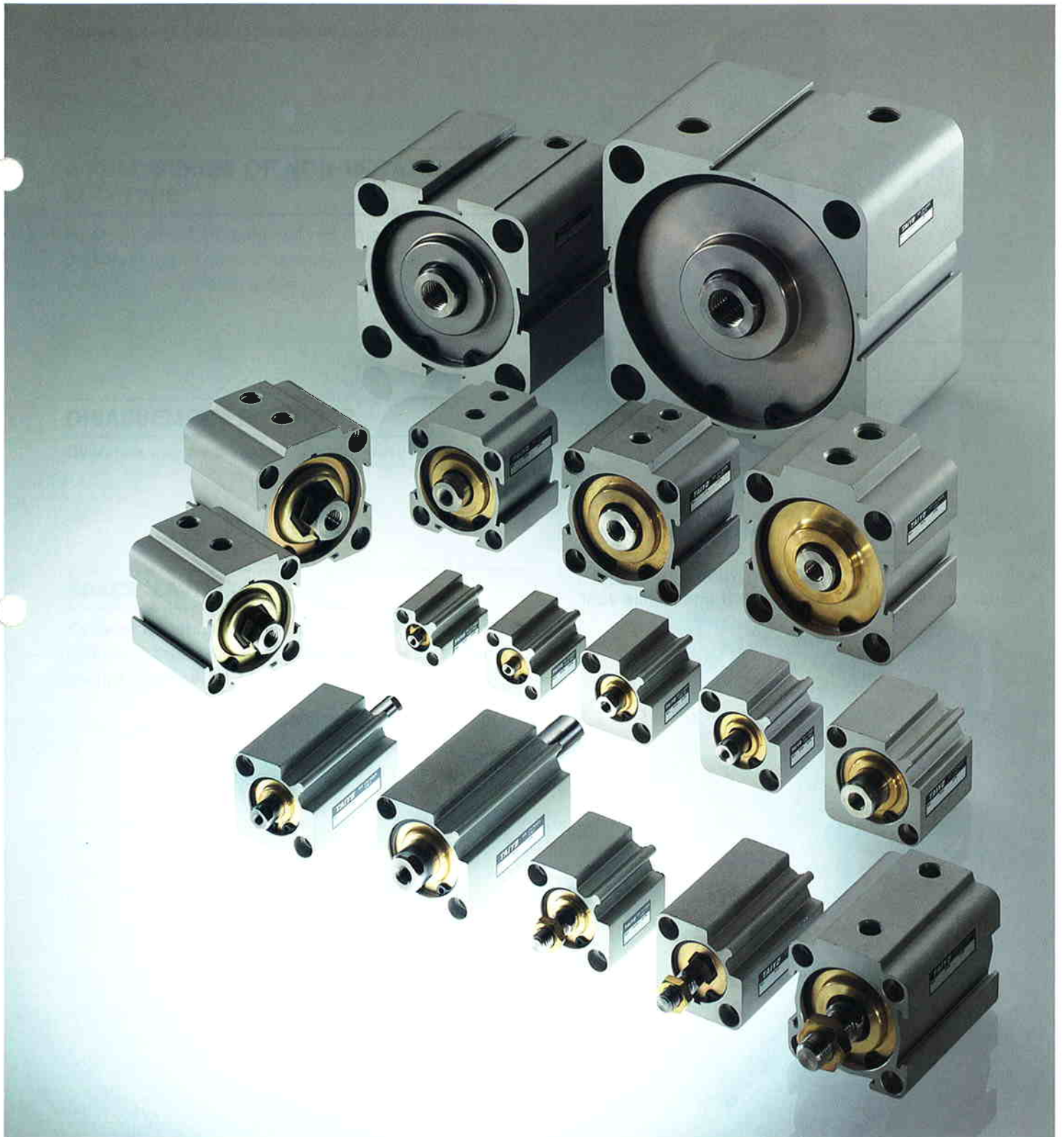

FEATURES

A VARIETY OF MODELS ADAPTABLE TO ALL APPLICATIONS

11 types of cylinder bores ranging from $\phi 12 \sim \phi 125$ are available. Double acting / single rod end, double acting / double rod end, single acting / spring return and single acting / spring push types are available.

A FULL SERIES OF NON-ROTATING ROD TYPE

Employment of a hexagonal rod on a full line of cylinders with bores ranging from $\phi 20 \sim \phi 100$ eliminates the need for a whirl-stop guide.

DISASSEMBLY POSSIBLE

Cylinders can be disassembled for easy to maintain.

SPACE SAVING

Cylinder length is about $1/2 \sim 1/3$ that of conventional cylinders, thus enabling space saving designs for jigs, clamps and special equipment etc.

JIGS MOUNTABLE AT CYLINDER ROD END

Rod end is equipped with a female thread (standard). Male thread (semi-standard) types are also available.



NON-LUBRICATING

Cylinders are the non-lubricating type requiring no lubrication.

EASY MOUNTING

The cylinder body is equipped with mounting holes, thus eliminating the need for mounting accessories.

10S-1/10S-1G COMPACT AIR CYLINDER

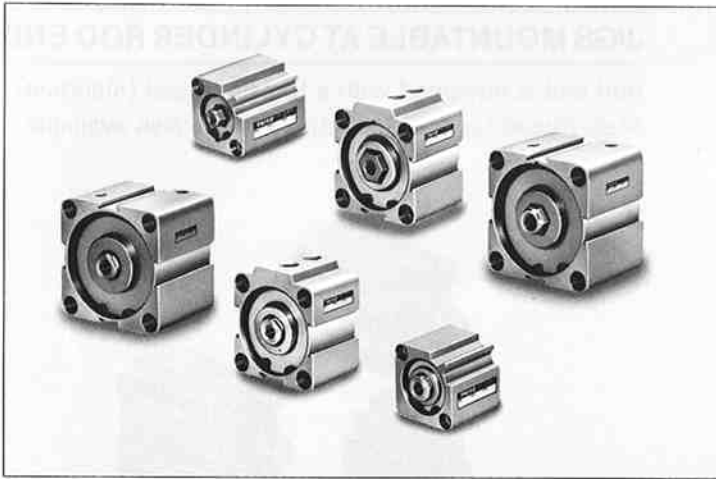

Ultra-compact, lightweight, space saving air cylinder.

- A variety of models adaptable to all applications.
- A full series of non-rotating rod cylinders.
- Easy to maintain disassembling type.
- Rod end is equipped with female thread (standard). Male thread (semi-standard) types are also available.
- Requires no mounting accessories and saves mounting space than conventional cylinders.
- Non-lubricating

SPECIFICATIONS / ROUND ROD

Structure	Double acting / single rod end	Double acting / double rod end	Single acting (SR type/SH type)
Cylinder bore (mm)	$\phi 12 \cdot \phi 16 \cdot \phi 20 \cdot \phi 25 \cdot \phi 32 \cdot \phi 40$ $\phi 50 \cdot \phi 63 \cdot \phi 80 \cdot \phi 100 \cdot \phi 125$	$\phi 12 \cdot \phi 16 \cdot \phi 20 \cdot \phi 25 \cdot \phi 32 \cdot \phi 40$ $\phi 50 \cdot \phi 63 \cdot \phi 80 \cdot \phi 100 \cdot \phi 125$	$\phi 12 \cdot \phi 16 \cdot \phi 20 \cdot \phi 25$ $\phi 32 \cdot \phi 40 \cdot \phi 50$
Working fluid	Air		
Lubrication	Unnecessary (but possible)		
Working pressure range	$\phi 12 \cdot \phi 16$: 0.07~1MPa $\phi 20 \sim \phi 125$: 0.05~1MPa		$\phi 12 \cdot \phi 16$: 0.2~1MPa $\phi 20 \cdot \phi 25$: 0.18~1MPa $\phi 32 \sim \phi 50$: 0.12~1MPa
Proof test pressure	1.5MPa		
Temperature range	-10~+70°C (Do not use when frozen.)		
Structure of cushioning	$\phi 12 \cdot \phi 16$: None	$\phi 20 \sim \phi 125$: With cushion pad	None
Tolerance for thread	JIS 6H/6g (JIS Class 2 or equivalent)		
Tolerance of stroke	+1.0 0mm		
Mounting type	Basic type		
Rod end threads	Standard : Female thread Semi-standard : Male thread		

SPECIFICATIONS / NON-ROTATING ROD

Structure	Double acting / single rod end
Cylinder bore (mm)	$\phi 20 \cdot \phi 25 \cdot \phi 32 \cdot \phi 40 \cdot \phi 50 \cdot \phi 63 \cdot \phi 80 \cdot \phi 100$
Working fluid	Air
Lubrication	Unnecessary (but possible)
Working pressure range	0.1~1MPa
Proof test pressure	1.5MPa
Temperature range	-10~+70°C (Do not use when frozen.)
Structure of cushioning	With cushion pad
Tolerance of rotation angle	$\phi 20 \cdot \phi 25$: $\pm 1.5^\circ$ $\phi 32 \sim \phi 63$: $\pm 1^\circ$ $\phi 80 \cdot \phi 100$: $\pm 0.8^\circ$
Max. allowable torque	$\phi 20 \cdot \phi 25$: 0.49N·m $\phi 32 \cdot \phi 40$: 0.98N·m $\phi 50 \cdot \phi 63$: 3.33N·m $\phi 80 \cdot \phi 100$: 9.61N·m
Tolerance for thread	JIS 6H/6g (JIS Class 2 or equivalent)
Tolerance of stroke	+1.0 0 mm
Mounting type	Basic type
Rod end threads	Standard : Female thread Semi-standard : Male thread

SINGLE ACTING SPRING FORCE TABLE











Unit : mm

Structure	Stroke mm	$\phi 12$		$\phi 16$		$\phi 20$		$\phi 25$		$\phi 32$		$\phi 40$		$\phi 50$		
		5	10	5	10	5	10	5	10	5	10	5	10	10	15	20
Single acting (SR type)	Initial load	1.0	0.8	1.5	1.1	1.9	1.6	2.4	2.0	3.4	2.9	4.4	3.9	5.8	5.0	4.2
	End load	1.2	1.8	2.2	2.9	4.0	4.9	7.4								
Single acting (SH type)	Initial load	0.3	0.5	0.6	0.7	0.6	0.7	2.3	2.3	2.4	—	2.4				
	End load	1.0	1.4	2.7	2.8	2.7	2.8	4.3	4.2	4.3	4.2	8.4	—	8.4		

Single acting (SR type) : Spring return type (Rod normally retracted)

Single acting (SH type) : Spring push type (Rod normally extended)

HOW TO ORDER

ROUND ROD	<ul style="list-style-type: none"> • Double acting / single rod end  <p>10S-1 SD 40 N 30 Series ① ②</p>	<ul style="list-style-type: none"> • Double acting / double rod end  <p>10S-1D SD 40 WN 30 Series ① Double rod ②</p>	<ul style="list-style-type: none"> • Male thread specifications  <p>Bore : $\phi 12 \sim \phi 32$</p>  <p>Bore : $\phi 40 \sim \phi 63$</p>  <p>Bore : $\phi 80 \sim \phi 125$</p>
	<ul style="list-style-type: none"> • Single acting / spring return type / SR type. (Rod normally retracted)  <p>10S-1 SD 40 N 10 -SR Series ① ② SR type</p>	<ul style="list-style-type: none"> • Single acting / spring push type / SH type. (Rod normally extended)  <p>10S-1 SD 40 N 10 -SH Series ① ② SH type</p>	
NON ROTATING ROD	<ul style="list-style-type: none"> • Double acting / single rod end  <p>10S-1G SD 40 GN 30 Series ① ②</p>	<ul style="list-style-type: none"> • Male thread specifications  <p>Bore : $\phi 20 \sim \phi 32$</p>  <p>Bore : $\phi 40 \sim \phi 63$</p>  <p>Bore : $\phi 80 \sim \phi 100$</p>	

SYMBOL EXPLANATION

①	Cylinder bore mm
②	Cylinder stroke mm

ORDERING

1. The following can be manufactured as semi-standard.

- Rod end modifications (Dimension symbol: WF·A·KK)
- Rod end thread : Male thread
- Cylinder stroke 35mm or 45mm

STANDARD STROKE RANGE

Unit : mm

	Structure	Cylinder bore	Stroke										With cushion pad	Male thread specifications	
			5	10	15	20	25	30	(35) ₍₁₎ ^(Note)	40	(45) ₍₂₎ ^(Note)	50			
ROUND ROD	Double acting /Single rod end	φ12	○	○	○	○	○	—	—	—	—	—	—	—	○
		φ16	○	○	○	○	○	—	—	—	—	—	—	—	○
		φ20	○	○	○	○	○	○	—	—	—	—	—	○	○
		φ25	○	○	○	○	○	○	—	—	—	—	—	○	○
		φ32	○	○	○	○	○	○	○	○	○	○	○	○	○
		φ40	○	○	○	○	○	○	○	○	○	○	○	○	○
		φ50	—	○	○	○	○	○	○	○	○	○	○	○	○
		φ63	—	○	○	○	○	○	○	○	○	○	○	○	○
		φ80	—	○	○	○	○	○	○	○	○	○	○	○	○
	φ100	—	○	○	○	○	○	○	○	○	○	○	○	○	
	φ125	—	○	○	○	○	○	○	○	○	○	○	○	○	
	Double acting /Double rod end	φ12	○	○	○	○	○	—	—	—	—	—	—	○	
		φ16	○	○	○	○	○	—	—	—	—	—	—	○	
		φ20	○	○	○	○	○	○	—	—	—	—	○	○	
		φ25	○	○	○	○	○	○	—	—	—	—	○	○	
		φ32	○	○	○	○	○	○	○	○	○	○	○	○	
		φ40	○	○	○	○	○	○	○	○	○	○	○	○	
		φ50	—	○	○	○	○	○	○	○	○	○	○	○	
		φ63	—	○	○	○	○	○	○	○	○	○	○	○	
		φ80	—	○	○	○	○	○	○	○	○	○	○	○	
	φ100	—	○	○	○	○	○	○	○	○	○	○	○		
	φ125	—	○	○	○	○	○	○	○	○	○	○	○		
	Single acting (Spring return type)	φ12	○	○	—	—	—	—	—	—	—	—	—	○	
		φ16	○	○	—	—	—	—	—	—	—	—	—	○	
		φ20	○	○	—	—	—	—	—	—	—	—	—	○	
		φ25	○	○	—	—	—	—	—	—	—	—	—	○	
		φ32	○	○	—	—	—	—	—	—	—	—	—	○	
		φ40	○	○	—	—	—	—	—	—	—	—	—	○	
	Single acting (Spring push type)	φ12	○	○	—	—	—	—	—	—	—	—	—	○	
		φ16	○	○	—	—	—	—	—	—	—	—	—	○	
		φ20	○	○	—	—	—	—	—	—	—	—	—	○	
		φ25	○	○	—	—	—	—	—	—	—	—	—	○	
		φ32	○	○	—	—	—	—	—	—	—	—	—	○	
		φ40	○	○	—	—	—	—	—	—	—	—	—	○	
	NON-ROTATING ROD	Double acting /Single rod end	φ20	○	○	○	○	○	○	—	—	—	—	○	○
			φ25	○	○	○	○	○	○	—	—	—	—	○	○
φ32			○	○	○	○	○	○	○	○	○	○	○	○	
φ40			○	○	○	○	○	○	○	○	○	○	○	○	
φ50			—	○	○	○	○	○	○	○	○	○	○	○	
φ63			—	○	○	○	○	○	○	○	○	○	○	○	
φ80			—	○	○	○	○	○	○	○	○	○	○	○	
φ100			—	○	○	○	○	○	○	○	○	○	○	○	

Consult with us concerning strokes other than the above standard strokes. (Note 1) Strokes (35) and (45) are semi-standard.

WEIGHT TABLE

Unit : gf

Bore mm	Basic weight (SD type)				Additional weight	
	Round rod		Non-rotating rod		Additional weight per 1mm of stroke	
	Double acting /Single rod end	Double acting /Double rod end	Single acting SR type	Single acting SH type	Round rod	Non-rotating rod
φ12	25	45	25	—	1.5	—
φ16	35	70	35	—	2	—
φ20	80	135	75	120	2.5	2.5
φ25	110	180	105	175	2.5	2.5
φ32	145	280	135	130	205	4.5
φ40	275	505	260	255	340	5.3
φ50	415	830	390	375	490	7.8
φ63	500	1,185	—	—	655	13.5
φ80	1,260	1,755	—	—	1,445	14.5
φ100	2,030	2,565	—	—	2,290	17
φ125	3,460	4,440	—	—	—	26

Calculation formula :

$$\text{Cylinder weight (gf)} = \text{Basic weight} + \text{Additional weight per 1mm of stroke} \times \text{Cylinder stroke (mm)}$$

Calculation example :

$$\text{Round rod} \cdot \text{Double acting / single rod end} \cdot \text{Bore } \phi 32 \cdot \text{Cylinder stroke } 50 \text{ (mm)}$$

$$145 + 4.8 \times 50 = 385 \text{ (gf)}$$

COMPACT AIR CYLINDER 10S-1/10S-1G

SECTIONAL DRAWINGS / ROUND ROD / DOUBLE ACTING / SINGLE ROD END

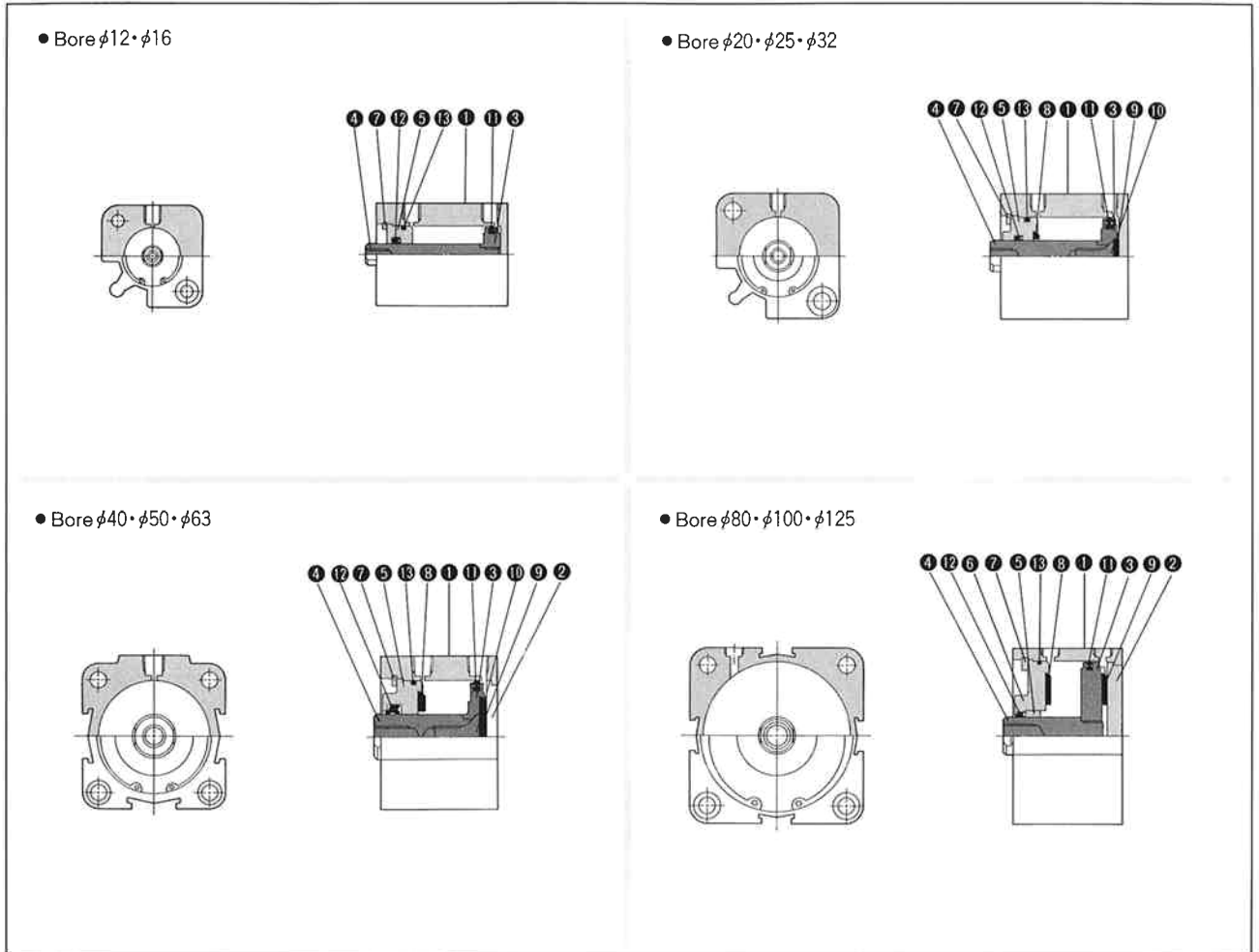

PARTS LIST

No.	Name	Material	Q'ty
①	Cylinder body	Aluminum alloy	1
②	Retainer	Aluminum alloy (φ40~φ125)	1
③	Piston	Copper alloy (φ12~φ63) Carbon steel (φ80~φ125)	1
④	Piston rod	Stainless steel (hard chrome plated) (φ12~φ32) Carbon steel (φ40~φ125)	1
⑤	Rod gland	Copper alloy (φ12~φ63) Aluminum alloy (with anti-abrasion surface treatment) (φ80~φ125)	1

No.	Name	Material	Q'ty
⑥	Rod gland housing	Aluminum alloy (φ80~φ125)	1
⑦	Stopper ring	Carbon steel	1
⑧	Cushion pad (R side)	Polyurethane rubber	1
⑨	Cushion pad (H side)	Polyurethane rubber	1
⑩	Piston stopper screw	Chromium-molybdenum steel (φ20~φ63)	1

SEALS LIST

Bore mm	Name	① Piston seal	② Rod seal	③ Rod gland O-ring
	Material	Nitrile rubber	Nitrile rubber	Nitrile rubber
	Q'ty	1	1	1
φ12		PSD-12	MYN-6	S-10
φ16		PSD-16	MYN-6	S-14
φ20		ZT-20	MYN-10	S-18
φ25		ZT-25	MYN-10	S-22
φ32		ZT-32	MYN-16	S-29
φ40		ZT-40	DRP-16	S-36
φ50		ZT-50	DRP-20	S-46
φ63		ZT-63	DRP-20	S-60
φ80		ZT-80	DRP-25	S-75
φ100		ZT-100	DRP-25	S-95
φ125		ZT-125	PRD-32	S-120

10S-1/10S-1G

COMPACT AIR CYLINDER

SECTIONAL DRAWINGS / ROUND ROD / DOUBLE ACTING / DOUBLE ROD END



• Bore $\phi 12 \cdot \phi 16$

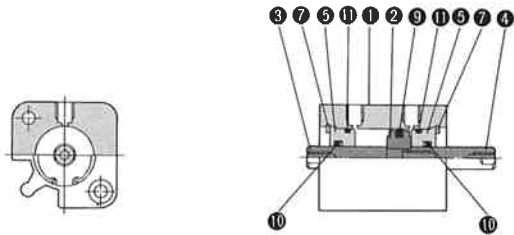

• Bore $\phi 20 \cdot \phi 25 \cdot \phi 32$

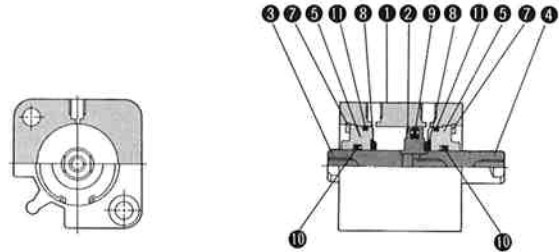

• Bore $\phi 40 \cdot \phi 50 \cdot \phi 63$

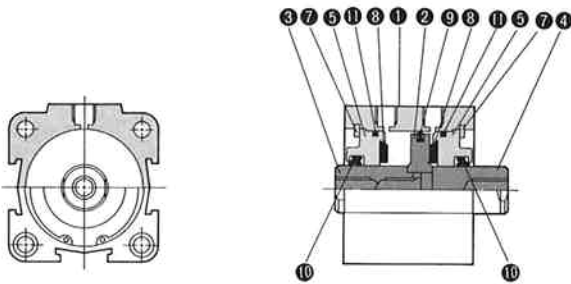

• Bore $\phi 80 \cdot \phi 100 \cdot \phi 125$

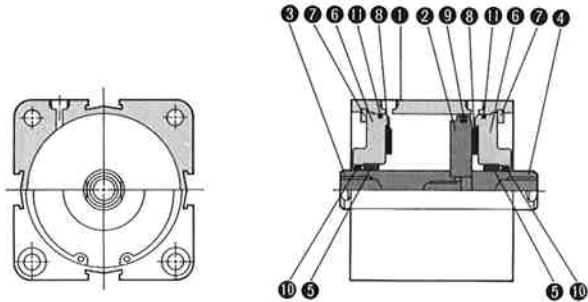

PARTS LIST

No.	Name	Material	Q'ty
①	Cylinder body	Aluminum alloy	1
②	Piston	Copper alloy ($\phi 12 \sim \phi 63$) Carbon steel ($\phi 80 \sim \phi 125$)	1
③	Piston rod A	Stainless steel (hard chrome plated) ($\phi 12 \sim \phi 32$) Carbon steel (hard chrome plated) ($\phi 40 \sim \phi 125$)	1
④	Piston rod B	Stainless steel (hard chrome plated) ($\phi 12 \sim \phi 32$) Carbon steel (hard chrome plated) ($\phi 40 \sim \phi 125$)	1

No.	Name	Material	Q'ty
⑤	Rod gland	Copper alloy ($\phi 12 \sim \phi 63$) Aluminum alloy ($\phi 80 \sim \phi 125$)	2
⑥	Rod gland housing	Aluminum alloy ($\phi 80 \sim \phi 125$)	2
⑦	Stopper ring	Carbon steel	2
⑧	Cushion pad	Polyurethane rubber	2

SEALS LIST

Bore mm	Name	⑨ Piston seal	⑩ Rod seal	⑪ Rod gland O-ring
	Material	Nitrile rubber	Nitrile rubber	Nitrile rubber
	Q'ty	1	2	2
$\phi 12$		PSD-12	MYN-6	S-10
$\phi 16$		PSD-16	MYN-6	S-14
$\phi 20$		ZT-20	MYN-10	S-18
$\phi 25$		ZT-25	MYN-10	S-22
$\phi 32$		ZT-32	MYN-16	S-29
$\phi 40$		ZT-40	DRP-16	S-36
$\phi 50$		ZT-50	DRP-20	S-46
$\phi 63$		ZT-63	DRP-20	S-60
$\phi 80$		ZT-80	DRP-25	S-75
$\phi 100$		ZT-100	DRP-25	S-95
$\phi 125$		ZT-125	PRD-32	S-120

SECTIONAL DRAWINGS / ROUND ROD / SINGLE ACTING SPRING RETURN TYPE (SR TYPE)



• Bore $\phi 12 \cdot \phi 16$

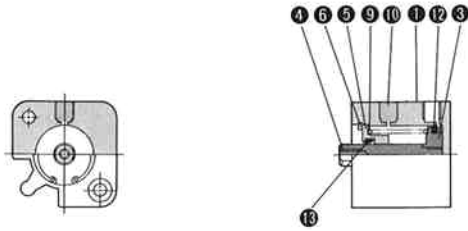

• Bore $\phi 20 \cdot \phi 25 \cdot \phi 32$

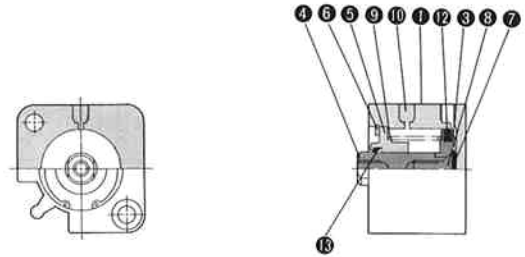

(Note) The rod gland dust wiper is not included with $\phi 12$.

• Bore $\phi 40 \cdot \phi 50$

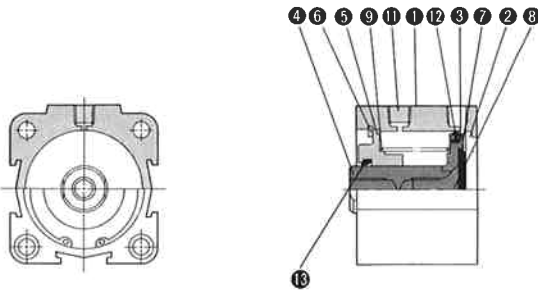

PARTS LIST

No.	Name	Material	Q'ty
①	Cylinder body	Aluminum alloy	1
②	Retainer	Aluminum alloy ($\phi 40 \cdot \phi 50$)	1
③	Piston	Copper alloy	1
④	Piston rod	Stainless steel (hard chrome plated) ($\phi 12 \sim \phi 32$) Carbon steel (hard chrome plated) ($\phi 40 \cdot \phi 50$)	1
⑤	Rod gland	Copper alloy	1
⑥	Stopper ring	Carbon steel	1

No.	Name	Material	Q'ty
⑦	Cushion pad	Polyurethane rubber ($\phi 20 \sim \phi 50$)	1
⑧	Piston stopper screw	Chromium-molybdenum steel ($\phi 20 \sim \phi 50$)	1
⑨	Spring	Piano wire	1
⑩	Filter	Resin ($\phi 12 \sim \phi 32$)	1
⑪	Filter plug	— ($\phi 40 \cdot \phi 50$)	1

SEALS LIST

Bore mm	Name	⑫ Piston seal	⑬ Rod gland dust wiper
	Material	Nitrile rubber	Nitrile rubber
	Q'ty	1	1
$\phi 12$		PSD-12	—
$\phi 16$		PSD-16	SER-6
$\phi 20$		ZT-20	SER-10
$\phi 25$		ZT-25	SER-10
$\phi 32$		ZT-32	SER-16
$\phi 40$		ZT-40	SER-16
$\phi 50$		ZT-50	SER-20

10S-1/10S-1G

COMPACT AIR CYLINDER

SECTIONAL DRAWINGS / ROUND ROD / SINGLE ACTING SPRING PUSH TYPE (SH TYPE)

M

• Bore $\phi 12 \cdot \phi 16$

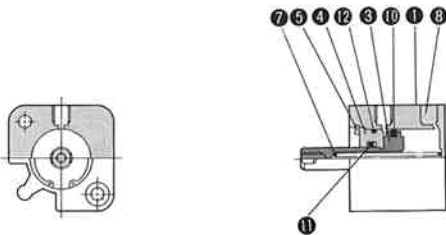

• Bore $\phi 20 \cdot \phi 25 \cdot \phi 32$

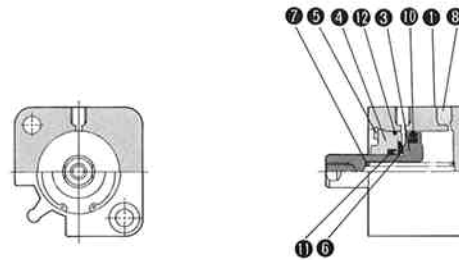

• Bore $\phi 40 \cdot \phi 50$

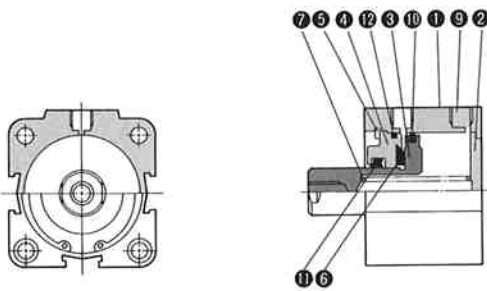

PARTS LIST

No.	Name	Material	Q'ty
①	Cylinder body	Aluminum alloy	1
②	Retainer	Aluminum alloy ($\phi 40 \cdot \phi 50$)	1
③	Piston·Piston rod	Stainless steel	1
④	Rod gland	Copper alloy	1
⑤	Stopper ring	Carbon steel	1

No.	Name	Material	Q'ty
⑥	Cushion pad	Polyurethane rubber ($\phi 20 \sim \phi 50$)	1
⑦	Spring	Piano wire	1
⑧	Filter	Resin ($\phi 12 \sim \phi 32$)	1
⑨	Filter plug	— ($\phi 40 \cdot \phi 50$)	1

SEALS LIST

Bore mm	Name	⑩ Piston seal	⑪ Rod seal	⑫ Rod gland O-ring
	Material	Nitrile rubber	Nitrile rubber	Nitrile rubber
	Q'ty	1	1	1
$\phi 12$		PSD-12	MYN-6	S-10
$\phi 16$		PSD-16	MYN-6	S-14
$\phi 20$		ZT-20	MYN-10	S-18
$\phi 25$		ZT-25	MYN-10	S-22
$\phi 32$		ZT-32	MYN-16	S-29
$\phi 40$		ZT-40	DRP-16	S-36
$\phi 50$		ZT-50	DRP-20	S-46

SECTIONAL DRAWINGS / NON-ROTATING ROD / DOUBLE ACTING / SINGLE ROD END

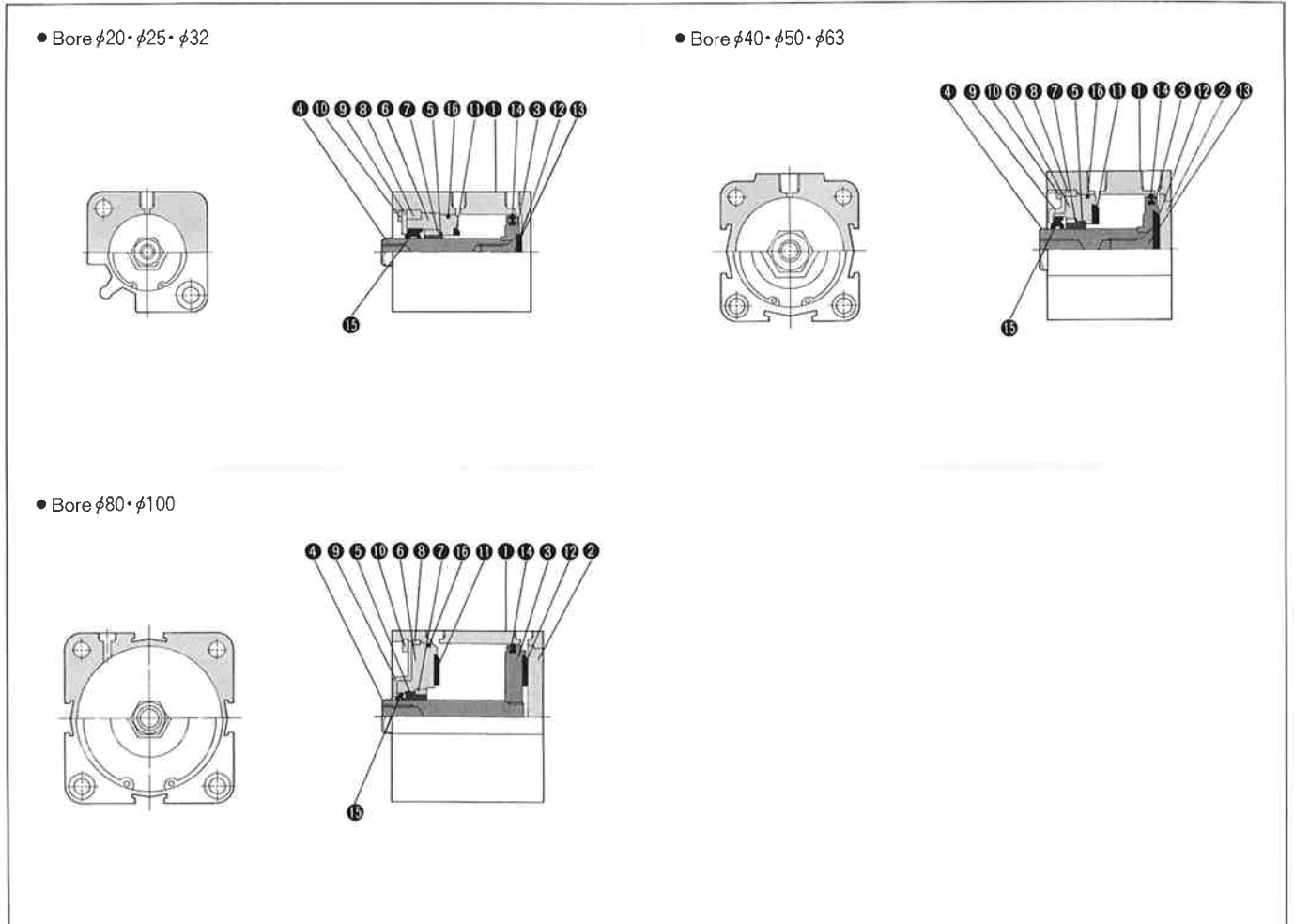

PARTS LIST

No.	Name	Material	Q'ty
①	Cylinder body	Aluminum alloy	1
②	Retainer	Aluminum alloy (φ40~φ100)	1
③	Piston	Copper alloy (φ20~φ63) Carbon steel (φ80 • φ100)	1
④	Piston rod	Carbon steel (hard chrome plated)	1
⑤	Rod gland	Sintered lubricated bearing (φ20~φ40) Aluminum alloy (with anti abrasion surface treatment) (φ50~φ100)	1
⑥	Rod gland housing	Copper alloy (φ20~φ63) Aluminum alloy (φ80 • φ100)	1
⑦	Spring pin	Stainless steel	1

No.	Name	Material	Q'ty
⑧	Parallel key	Carbon steel	1
⑨	Rod seal retainer	Cold rolled carbon steel	1
⑩	Stopper ring	Carbon steel	1
⑪	Cushion pad (R side)	Polyurethane rubber	1
⑫	Cushion pad (H side)	Polyurethane rubber	1
⑬	Piston stopper screw	Chromium-molybdenum steel (φ20~φ63)	1

SEALS LIST

Bore mm	Name	⑬ Piston seal	⑩ Rod seal	⑬ Rod gland O-ring
	Material	Nitrile rubber	Polyurethane rubber	Nitrile rubber
	Q'ty	1	1	1
φ20		ZT-20	PGR-9	S-18
φ25		ZT-25	PGR-9	S-22
φ32		ZT-32	PGR-14A	S-29
φ40		ZT-40	PGR-14A	S-36
φ50		ZT-50	PGR-19	S-46
φ63		ZT-63	PGR-19	S-60
φ80		ZT-80	PGR-23	S-75
φ100		ZT-100	PGR-23	S-95

10S-1/10S-1G COMPACT AIR CYLINDER

DIMENSIONAL DRAWINGS / ROUND ROD / DOUBLE ACTING / SINGLE ROD END

Unit : mm

10S-1 SD Bore N Stroke

• Bore $\phi 12 \sim \phi 32$

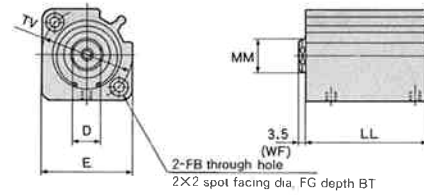

• 5 stroke

• Over 10 stroke

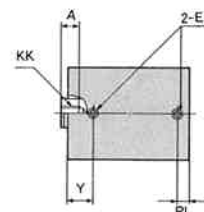
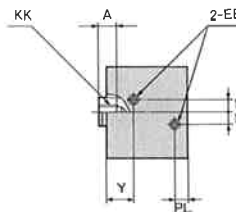

- Bore $\phi 12 \sim \phi 40$: Port position differs with strokes 5 and over 10.
- Bore $\phi 50 \cdot \phi 63$: Port position differs with strokes 10 and over 15.

• Bore $\phi 40 \sim \phi 63$

Bore $\phi 40$: 5 stroke
Bore $\phi 50 \cdot \phi 63$: 10 stroke

Bore $\phi 40$: Over 10 stroke
Bore $\phi 50 \cdot \phi 63$: Over 15 stroke

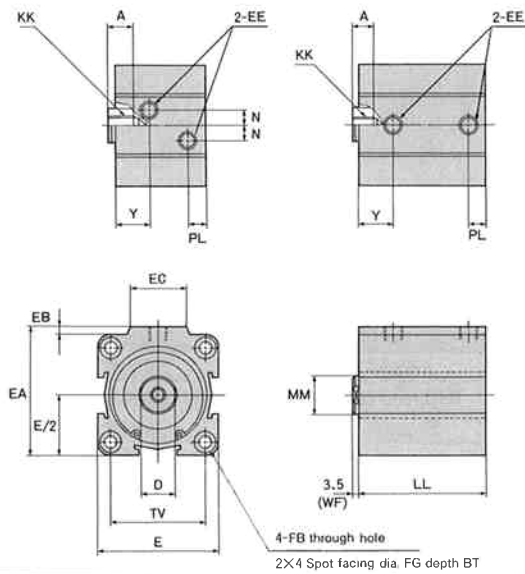

• Bore $\phi 80 \sim \phi 125$

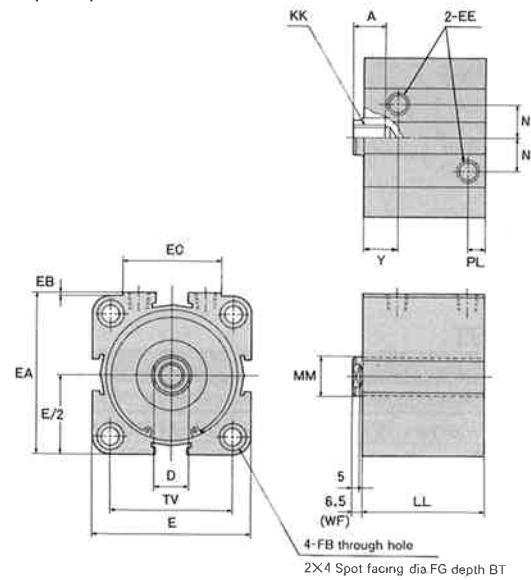

DIMENSIONAL TABLE

• Values in parentheses are for 5 stroke specifications.

Symbol Stroke Bore	A	BT	D	E	EA	EB	EC	EE	FB	FG	KK	LL								MM	N	PL	TV	Y		
												5	10	15	20	25	30	35	40						45	50
$\phi 12$	6	3.5	5	□25	—	—	—	M5X0.8	$\phi 3.4$	$\phi 6.5$	M 3 X 0.5	22	27	32	37	42	—	—	—	—	—	$\phi 6$	2	5	$\phi 22$	10(8.5)
$\phi 16$	6	3.5	5	□29	—	—	—	M5X0.8	$\phi 3.4$	$\phi 6.5$	M 3 X 0.5	22	27	32	37	42	—	—	—	—	—	$\phi 6$	2	5	$\phi 28$	10(8.5)
$\phi 20$	7	5.5	8	□37	—	—	—	M5X0.8	$\phi 5.5$	$\phi 9.5$	M 5 X 0.8	25	30	35	40	45	50	—	—	—	—	$\phi 10$	4.5	6	$\phi 36$	11
$\phi 25$	7	5.5	8	□40	—	—	—	M5X0.8	$\phi 5.5$	$\phi 9.5$	M 5 X 0.8	26	31	36	41	46	51	—	—	—	—	$\phi 10$	4.5	6	$\phi 40$	12
$\phi 32$	12	5.5	14	□45	—	—	—	M5X0.8	$\phi 5.5$	$\phi 9.5$	M 8 X 1.25	30	35	40	45	50	55	60	65	70	75	$\phi 16$	5	6	$\phi 48$	13
$\phi 40$	12	5.5	14	53	57	4	28	PT $\frac{1}{8}$	$\phi 5.5$	$\phi 9.5$	M 8 X 1.25	35	40	45	50	55	60	65	70	75	80	$\phi 16$	5	8.5	□40	16.5
$\phi 50$	15	6.5	18	64	68	4	30	PT $\frac{1}{8}$	$\phi 6.6$	$\phi 11$	M10X1.5	—	42	47	52	57	62	67	72	77	82	$\phi 20$	6	9	□50	18
$\phi 63$	15	8.6	18	77	84	7	35	PT $\frac{1}{4}$	$\phi 9$	$\phi 14$	M10X1.5	—	46	51	56	61	66	71	76	81	86	$\phi 20$	6	11	□60	19
$\phi 80$	20	16.5	22	100	101.5	1.5	62	PT $\frac{1}{4}$	$\phi 11$	$\phi 17.5$	M16X2	—	56.5	61.5	66.5	71.5	76.5	81.5	86.5	91.5	96.5	$\phi 25$	21	11	□77	21.5
$\phi 100$	20	18	22	117	117	—	—	PT $\frac{1}{4}$	$\phi 11$	$\phi 17.5$	M16X2	—	63	68	73	78	83	88	93	98	103	$\phi 25$	29	13	□94	25
$\phi 125$	25	19.5	29	144	144	—	—	PT $\frac{3}{8}$	$\phi 14$	$\phi 20$	M20X2.5	—	69.5	74.5	79.5	84.5	89.5	94.5	99.5	104.5	109.5	$\phi 32$	37	16	□116	28

COMPACT AIR CYLINDER 10S-1/10S-1G

DIMENSIONAL DRAWINGS / ROUND ROD / DOUBLE ACTING / DOUBLE ROD END



Unit : mm

10S-1D SD Bore WN Stroke

• Bore $\phi 12 \sim \phi 32$

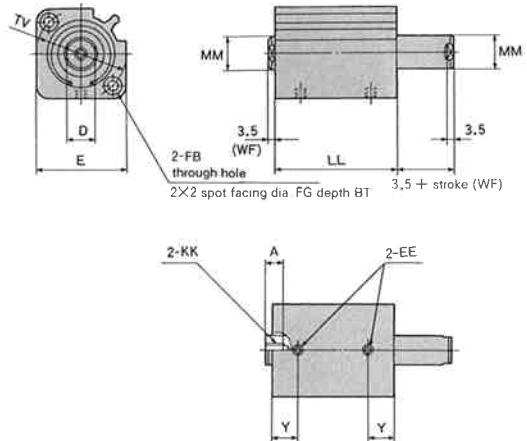
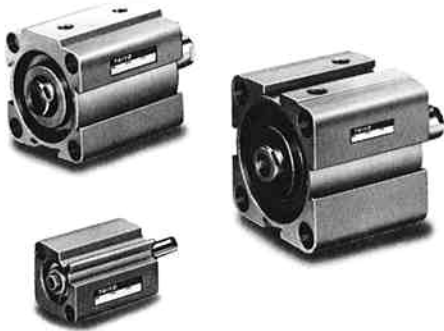

• Bore $\phi 40 \sim \phi 63$

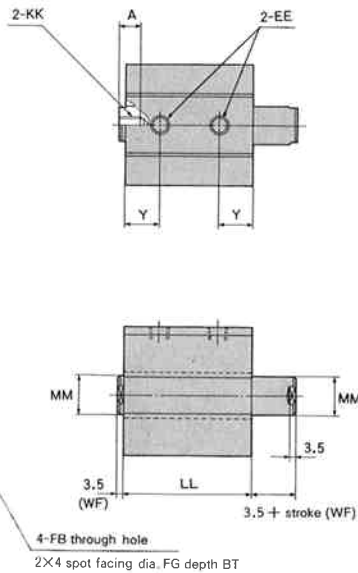

• Bore $\phi 80 \sim \phi 125$

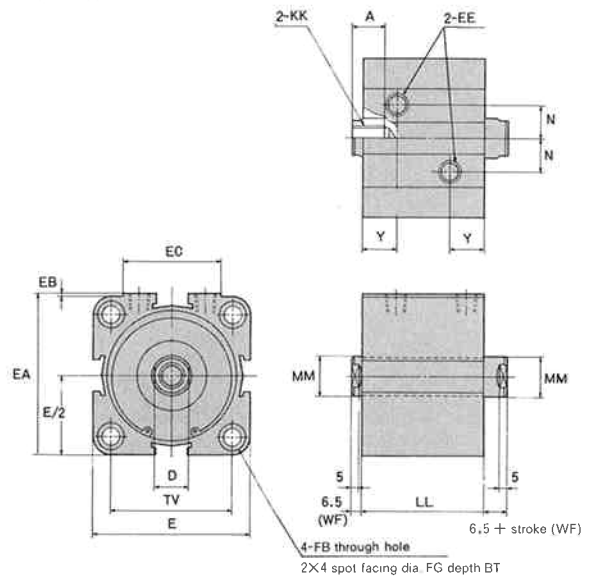

DIMENSIONAL TABLE

Symbol Stroke Bore	A	BT	D	E	EA	EB	EC	EE	FB	FG	KK	LL										MM	N	TV	Y
												5	10	15	20	25	30	35	40	45	50				
$\phi 12$	6	3.5	5	$\square 25$	—	—	—	M5X0.8	$\phi 3.4$	$\phi 6.5$	M3X0.5	32	37	42	47	52	—	—	—	—	—	$\phi 6$	—	$\phi 22$	10
$\phi 16$	6	3.5	5	$\square 29$	—	—	—	M5X0.8	$\phi 3.4$	$\phi 6.5$	M3X0.5	32	37	42	47	52	—	—	—	—	—	$\phi 6$	—	$\phi 28$	10
$\phi 20$	7	5.5	8	$\square 37$	—	—	—	M5X0.8	$\phi 5.5$	$\phi 9.5$	M5X0.8	35	40	45	50	55	60	—	—	—	—	$\phi 10$	—	$\phi 36$	11
$\phi 25$	7	5.5	8	$\square 40$	—	—	—	M5X0.8	$\phi 5.5$	$\phi 9.5$	M5X0.8	36	41	46	51	56	61	—	—	—	—	$\phi 10$	—	$\phi 40$	12
$\phi 32$	12	5.5	14	$\square 45$	—	—	—	M5X0.8	$\phi 5.5$	$\phi 9.5$	M 8X1.25	40	45	50	55	60	65	70	75	80	85	$\phi 16$	—	$\phi 48$	13
$\phi 40$	12	5.5	14	53	57	4	28	PT $\frac{1}{8}$	$\phi 5.5$	$\phi 9.5$	M8X1.25	50	55	60	65	70	75	80	85	90	95	$\phi 16$	—	$\square 40$	16.5
$\phi 50$	15	6.5	18	64	68	4	30	PT $\frac{1}{8}$	$\phi 6.6$	$\phi 11$	M10X1.5	—	57	62	67	72	77	82	87	92	97	$\phi 20$	—	$\square 50$	18
$\phi 63$	15	8.6	18	77	84	7	35	PT $\frac{1}{4}$	$\phi 9$	$\phi 14$	M10X1.5	—	61	66	71	76	81	86	91	96	101	$\phi 20$	—	$\square 60$	19
$\phi 80$	20	16.5	22	100	101.5	1.5	62	PT $\frac{1}{4}$	$\phi 11$	$\phi 17.5$	M16X2	—	71.5	76.5	81.5	86.5	91.5	96.5	101.5	106.5	111.5	$\phi 25$	21	$\square 77$	21.5
$\phi 100$	20	18	22	117	117	—	—	PT $\frac{1}{4}$	$\phi 11$	$\phi 17.5$	M16X2	—	78	83	88	93	98	103	108	113	118	$\phi 25$	29	$\square 94$	25
$\phi 125$	25	19.5	29	144	144	—	—	PT $\frac{3}{8}$	$\phi 14$	$\phi 20$	M20X2.5	—	84.5	89.5	94.5	99.5	104.5	109.5	114.5	119.5	124.5	$\phi 32$	37	$\square 116$	28

10S-1/10S-1G COMPACT AIR CYLINDER

DIMENSIONAL DRAWINGS / ROUND ROD / SINGLE ACTING SPRING RETURN TYPE

Unit : mm

10S-1 SD Bore N Stroke -SR

• Bore $\phi 12 \sim \phi 32$

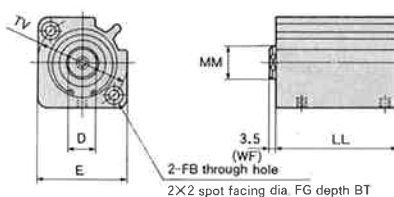

• 5 stroke

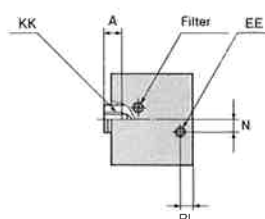

• 10 stroke

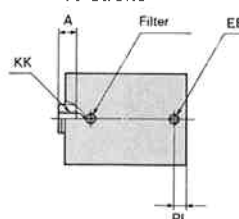

• Bore $\phi 40 \sim \phi 50$

Bore $\phi 40$: 5 stroke
Bore $\phi 50$: 10 stroke

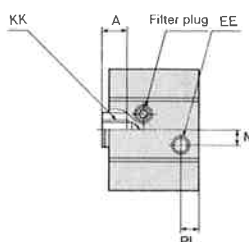

Bore $\phi 40$: 10 stroke
Bore $\phi 50$: 15 stroke - 20 stroke

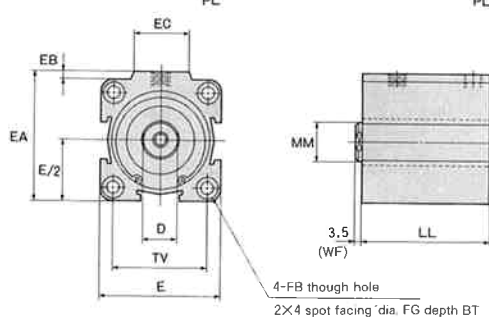
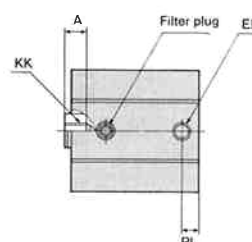

• Bore $\phi 12 \sim \phi 40$: Port position differs with strokes above 5 and 10.

• Bore $\phi 50$: Port position differs with strokes above 10 and 15-20.

DIMENSIONAL TABLE

Symbol Stroke Bore	A	BT	D	E	EA	EB	EC	EE	FB	FG	KK	LL				MM	N	PL	TV
												5	10	15	20				
$\phi 12$	6	3.5	5	□25	—	—	—	M5X0.8	$\phi 3.4$	$\phi 6.5$	M3X0.5	22	27	—	—	$\phi 6$	2	5	$\phi 22$
$\phi 16$	6	3.5	5	□29	—	—	—	M5X0.8	$\phi 3.4$	$\phi 6.5$	M3X0.5	22	27	—	—	$\phi 6$	2	5	$\phi 28$
$\phi 20$	7	5.5	8	□37	—	—	—	M5X0.8	$\phi 5.5$	$\phi 9.5$	M5X0.8	25	30	—	—	$\phi 10$	4.5	6	$\phi 36$
$\phi 25$	7	5.5	8	□40	—	—	—	M5X0.8	$\phi 5.5$	$\phi 9.5$	M5X0.8	26	31	—	—	$\phi 10$	4.5	6	$\phi 40$
$\phi 32$	12	5.5	14	□45	—	—	—	M5X0.8	$\phi 5.5$	$\phi 9.5$	M8X1.25	30	35	—	—	$\phi 16$	5	6	$\phi 48$
$\phi 40$	12	5.5	14	53	57	4	28	PT $\frac{1}{8}$	$\phi 5.5$	$\phi 9.5$	M8X1.25	35	40	—	—	$\phi 16$	5	8.5	□40
$\phi 50$	15	6.5	18	64	68	4	30	PT $\frac{1}{8}$	$\phi 6.6$	$\phi 11$	M10X1.5	—	42	47	52	$\phi 20$	6	9	□50

COMPACT AIR CYLINDER 10S-1/10S-1G

DIMENSIONAL DRAWINGS / ROUND ROD / SINGLE ACTING SPRING PUSH TYPE

Unit : mm

10S-1 SD Bore N Stroke -SH

• Bore $\phi 12 \sim \phi 32$

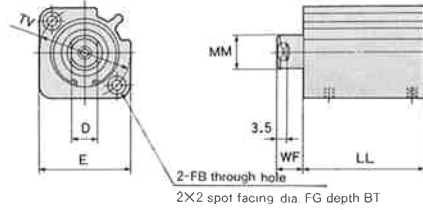
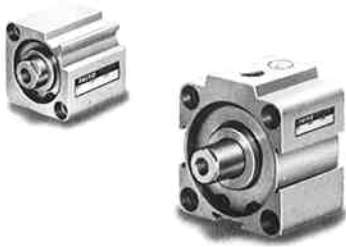

• 5 stroke

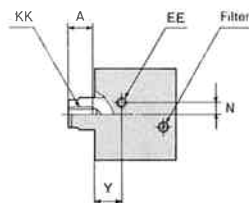

• 10 stroke

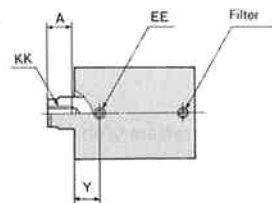

• Bore $\phi 40 \sim \phi 50$

Bore $\phi 40$: 5 stroke
Bore $\phi 50$: 10 stroke

Bore $\phi 40$: 10 stroke
Bore $\phi 50$: 20 stroke

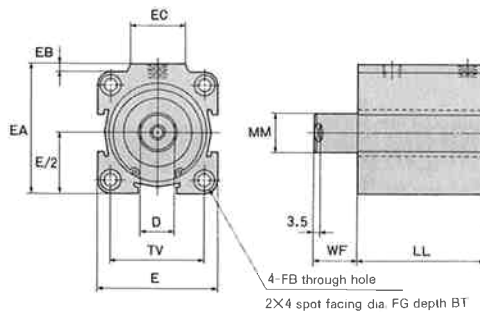
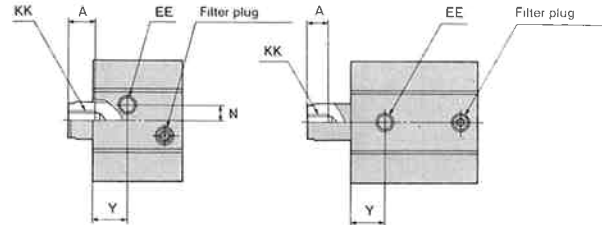

• Bore $\phi 12 \sim \phi 40$: Port position differs with strokes above 5 and 10.

• Bore $\phi 50$: Port position differs with strokes above 10 and 15·20.

DIMENSIONAL TABLE

• Values in parentheses are for 5 stroke specifications.

Symbol Stroke Bore	A	BT	D	E	EA	EB	EC	EE	FB	FG	KK	LL			MM	N	TV	WF			Y
												5	10	20				5	10	20	
$\phi 12$	6	3.5	5	$\square 25$	—	—	—	M5X0.8	$\phi 3.4$	$\phi 6.5$	M3X0.5	22	27	—	$\phi 6$	2	$\phi 22$	8.5	13.5	—	10(8.5)
$\phi 16$	6	3.5	5	$\square 29$	—	—	—	M5X0.8	$\phi 3.4$	$\phi 6.5$	M3X0.5	22	27	—	$\phi 6$	2	$\phi 28$	8.5	13.5	—	10(8.5)
$\phi 20$	7	5.5	8	$\square 37$	—	—	—	M5X0.8	$\phi 5.5$	$\phi 9.5$	M5X0.8	25	30	—	$\phi 10$	4.5	$\phi 36$	8.5	13.5	—	11
$\phi 25$	7	5.5	8	$\square 40$	—	—	—	M5X0.8	$\phi 5.5$	$\phi 9.5$	M5X0.8	26	31	—	$\phi 10$	4.5	$\phi 40$	8.5	13.5	—	12
$\phi 32$	12	5.5	14	$\square 45$	—	—	—	M5X0.8	$\phi 5.5$	$\phi 9.5$	M8X1.25	30	35	—	$\phi 16$	5	$\phi 48$	8.5	13.5	—	13
$\phi 40$	12	5.5	14	53	57	4	28	PT $\frac{1}{8}$	$\phi 5.5$	$\phi 9.5$	M8X1.25	35	40	—	$\phi 16$	5	$\square 40$	8.5	13.5	—	16.5
$\phi 50$	15	6.5	18	64	68	4	30	PT $\frac{1}{8}$	$\phi 6.6$	$\phi 11$	M10X1.5	—	42	52	$\phi 20$	6	$\square 50$	—	13.5	23.5	18

10S-1/10S-1G COMPACT AIR CYLINDER

DIMENSIONAL DRAWINGS / NON-ROTATING ROD / DOUBLE ACTING / SINGLE ROD END

 Unit : mm

10S-1G SD Bore GN Stroke

• Bore $\phi 20 \sim \phi 32$

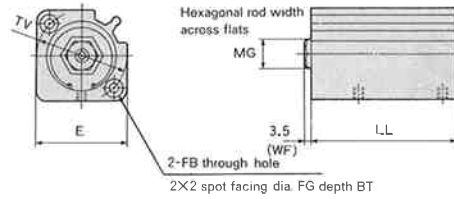

• 5 stroke

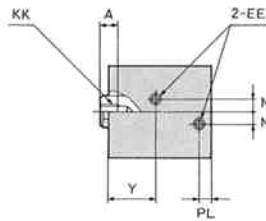

• Over 10 stroke

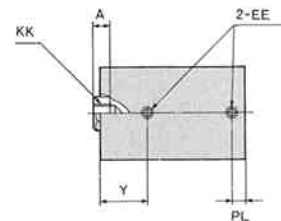

- Bore $\phi 20 \sim \phi 40$: Port position differs with strokes above 5 and over 10.
- Bore $\phi 50 \cdot \phi 63$: Port position differs with strokes above 10 and over 15.

• Bore $\phi 40 \sim \phi 63$

Bore $\phi 40$: 5 stroke
Bore $\phi 50 \cdot \phi 63$: 10 stroke

Bore $\phi 40$: Over 10 stroke
Bore $\phi 50 \cdot \phi 63$: Over 15 stroke

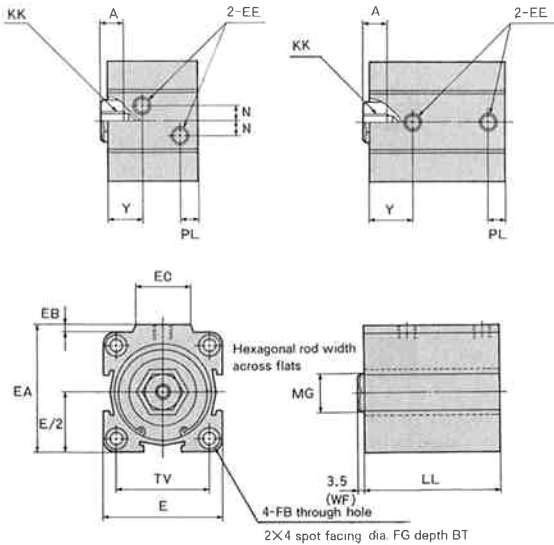

• Bore $\phi 80 \cdot \phi 100$

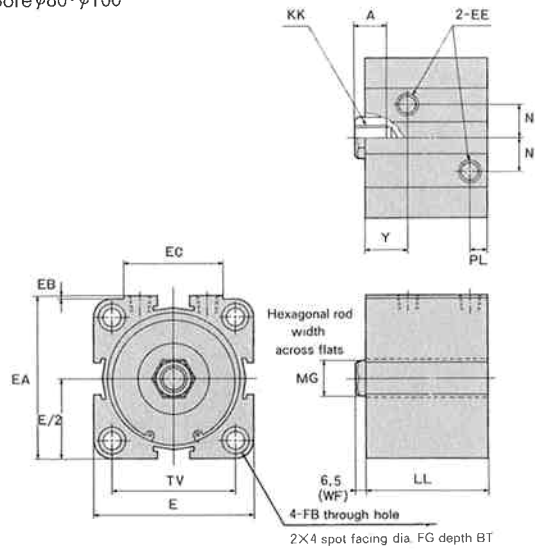

DIMENSIONAL TABLE

Symbol Stroke Bore	A	BT	E	EA	EB	EC	EE	FB	FG	KK	LL										MG	N	PL	TV	Y
											5	10	15	20	25	30	35	40	45	50					
$\phi 20$	7	5.5	$\square 37$	—	—	—	M5X0.8	$\phi 5.5$	$\phi 9.5$	M5X0.8	35	40	45	50	55	60	—	—	—	—	9	4.5	6	$\phi 36$	21
$\phi 25$	7	5.5	$\square 40$	—	—	—	M5X0.8	$\phi 5.5$	$\phi 9.5$	M5X0.8	36	41	46	51	56	61	—	—	—	—	9	4.5	6	$\phi 40$	22
$\phi 32$	12	5.5	$\square 45$	—	—	—	M5X0.8	$\phi 5.5$	$\phi 9.5$	M8X1.25	40	45	50	55	60	65	70	75	80	85	14	5	6	$\phi 48$	23
$\phi 40$	12	5.5	53	57	4	28	PT $\frac{1}{8}$	$\phi 5.5$	$\phi 9.5$	M8X1.25	40	45	50	55	60	65	70	75	80	85	14	5	8.5	$\square 40$	21.5
$\phi 50$	15	6.5	64	68	4	30	PT $\frac{1}{8}$	$\phi 6.6$	$\phi 11$	M10X1.5	—	47	52	57	62	67	72	77	82	87	19	6	9	$\square 50$	23
$\phi 63$	15	8.6	77	84	7	35	PT $\frac{1}{4}$	$\phi 9$	$\phi 14$	M10X1.5	—	51	56	61	66	71	76	81	86	91	19	6	11	$\square 60$	24
$\phi 80$	20	16.5	100	101.5	1.5	62	PT $\frac{1}{4}$	$\phi 11$	$\phi 17.5$	M16X2	—	61.5	66.5	71.5	76.5	81.5	86.5	91.5	96.5	101.5	23	21	11	$\square 77$	26.5
$\phi 100$	20	18	117	117	—	—	PT $\frac{1}{4}$	$\phi 11$	$\phi 17.5$	M16X2	—	68	73	78	83	88	93	98	103	108	23	29	13	$\square 94$	30

COMPACT AIR CYLINDER 10S-1/10S-1G

ROD END MALE THREAD SPECIFICATIONS

Unit : mm

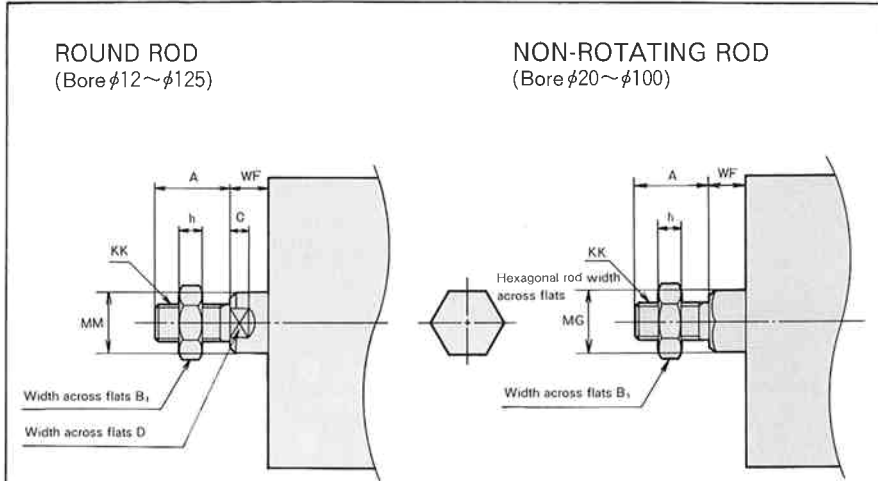

DIMENSIONAL TABLE

Bore	Symbol	A	B ₁	C	D	h	KK	MG	MM	WF
$\phi 12$		10	8	3.5	5	3.2	M 5 × 0.8	—	$\phi 6$	3.5
$\phi 16$		10	8	3.5	5	3.2	M 5 × 0.8	—	$\phi 6$	3.5
$\phi 20$		16	13	3.5	8	5	M 8 × 1.25	9	$\phi 10$	5
$\phi 25$		16	13	3.5	8	5	M 8 × 1.25	9	$\phi 10$	5
$\phi 32$		24	19	3.5	14	7	M 12 × 1.25	14	$\phi 16$	5
$\phi 40$		24	19	3.5	14	7	M 12 × 1.25	14	$\phi 16$	5
$\phi 50$		32	22	3.5	18	10	M 16 × 1.5	19	$\phi 20$	5
$\phi 63$		32	22	3.5	18	10	M 16 × 1.5	19	$\phi 20$	5
$\phi 80$		40	27	5	22	12	M 20 × 1.5	23	$\phi 25$	6.5
$\phi 100$		40	27	5	22	12	M 20 × 1.5	23	$\phi 25$	6.5
$\phi 125$		54	36	5	29	16	M 27 × 2	—	$\phi 32$	6.5

BODY IN GLAND PORTION DIMENSIONS

Unit : mm

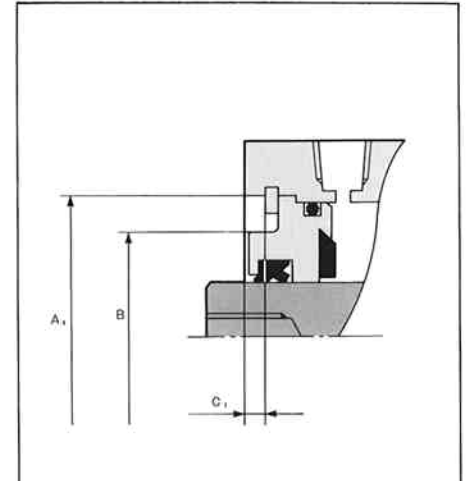

DIMENSIONAL TABLE

Bore	Item	B		C ₁
		Round rod	Non-rotating rod	
$\phi 12$	$\phi 13H8$	—	—	1.5 ⁰ _{-0.1}
$\phi 16$	$\phi 17H8$	—	—	1.5 ⁰ _{-0.1}
$\phi 20$	$\phi 22H8$	$\phi 13$	—	1.9 ⁰ _{-0.1}
$\phi 25$	$\phi 26H8$	$\phi 16$	—	1.7 ⁰ _{-0.1}
$\phi 32$	$\phi 34H8$	$\phi 22.5$	—	2 ⁰ _{-0.1}
$\phi 40$	$\phi 42H8$	$\phi 29.5$	$\phi 30$	3.5 ⁰ _{-0.1}
$\phi 50$	$\phi 52H8$	$\phi 36$	$\phi 37.5$	4 ⁰ _{-0.1}
$\phi 63$	$\phi 65H8$	$\phi 36$	$\phi 40.5$	5 ⁰ _{-0.1}
$\phi 80$	$\phi 82H8$	$\phi 50$	$\phi 50$	4.5 ⁰ _{-0.1}
$\phi 100$	$\phi 102H8$	$\phi 55$	$\phi 55$	5.8 ⁰ _{-0.1}
$\phi 125$	$\phi 130H8$	$\phi 60$	—	7 ⁰ _{-0.1}

APPLICATIONS

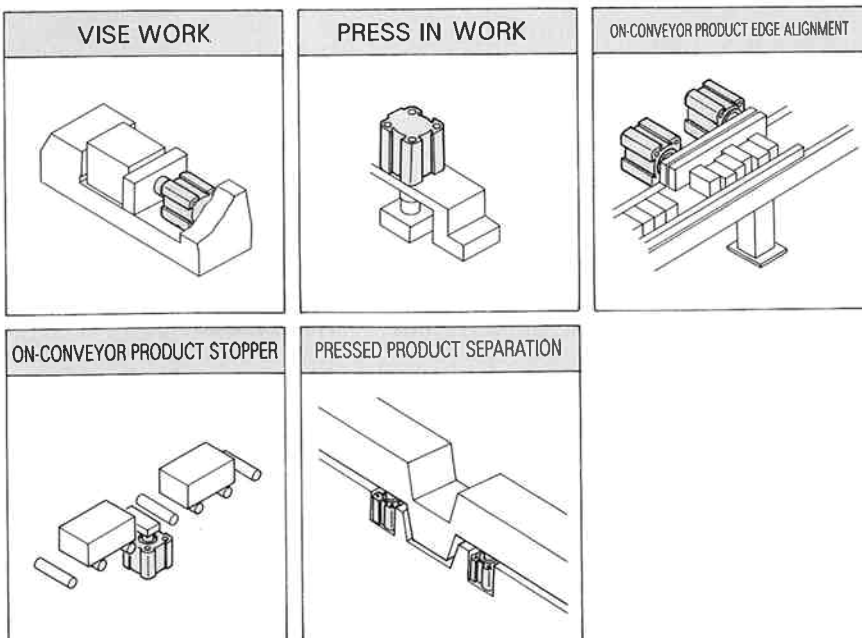

HANDLING INSTRUCTIONS

General precautions

- Do not use with a radial (bending) load on to the piston rod. Perform careful centering when install.
- We recommend using small pipe fittings (MC4-M5) for cylinder bore $\phi 12$ and $\phi 16$ pipe fittings. When using small pipe fittings, we recommend using polyurethane tube/U2 series (maximum working pressure 5 kgf/cm²).

For further information, please contact :

TAIYO, LTD.

TOKYO OFFICE

Imaasa Bldg.,
1-1-21, Higashi-Shinbashi, Minato-ku, Tokyo 105-0021, Japan
PHONE : (03) 5568-6231
FAX : (03) 5568-6237

For further information, please contact :

TAIYO AMERICA, INC.

CHICAGO HEAD OFFICE

1120 North Dupage Avenue
Lombard, IL 60148
Phone : 630/691-8811
Fax : 630/697-8817

LOS ANGELES OFFICE

1630 South Sunkist # L
Anaheim, CA 92806
Phone : 714/634-3727
Fax : 714/634-3754

COLUMBUS OFFICE

6631 Commerce Parkway Suite N
Dublin, OH 43017
Phone : 614/793-8995
Fax : 614/793-8980

March 1999

