

STRONG FORCE TYPE AIR CYLINDER 10A-3



Strong Force Type Air Cylinder with Adoption of Large Rod Dia.

— Bore $\phi 50 \sim \phi 250$.

- With adoption of large rod dia., strong force type air cylinder of excellent durability that resists the large shock and severe use condition.
- The plenty of mounting accessories, rod end attachments and brackets allows the selection of suitable mounting method.
- With the diameter of rod and rod end screw thickened, there is stronger force than that of 10A-2 series against side load on rod end.

CYLINDER SPECIFICATIONS

Series	10A-3	
Cylinder bore (mm)	$\phi 50 \cdot \phi 63 \cdot \phi 80 \cdot \phi 100 \cdot \phi 125 \cdot \phi 160 \cdot \phi 180 \cdot \phi 200 \cdot \phi 250$	
Working fluid	Air	
Lubrication	Unnecessary (but possible)	
Operating pressure range	1~9.9kgf/cm ² (0.098~0.971MPa)	
Proof test pressure	15kgf/cm ² (1.471MPa)	
Speed range	50~700mm/sec	
Temperature range	-10~+70°C	
Structure of cushioning	Both ends cushioned	
Cushion stroke (Cushion ring length)	$\phi 50 \sim \phi 63$: 16mm	$\phi 80 \sim \phi 125$: 20mm $\phi 160 \sim \phi 200$: 23mm $\phi 250$: 25mm
Tolerance for thread	ISO 4795/1 6g	
Tolerance of stroke	max. 250mm ^{+1.0} ₀ 251~1000mm ^{+1.4} ₀ 1001~2000mm ^{+1.8} ₀	
Mounting type	SD·LB·FA·FB·CA CB·CC·CD·TA·TC	
Accessories	Boots	Standard : Nylon tarpaulin Semi-standard : Neoprene·Almix
	Rod end attachment	Rod end eye (T type) · Rod end clevis (Y type) with pin
	Others	CB/CD bracket · TA/TC bracket

MAXIMUM STROKE

Unit : mm

Bore	$\phi 50 \cdot \phi 63$	$\phi 80 \cdot \phi 100$	$\phi 125 \sim \phi 250$
Max. stroke	1400	1800	2000

The above is the standard for fabrication. The buckling of piston rod shall be separately studied. Consult to us for stroke exceeding the above.

CODE For order, specify the following code.

10A-3 **LB** **80** **B** **200** - **A** **B**

Series ① ② ③ ④ ⑤ ⑥

Indication examples : LB type · Cylinder bore $\phi 80$ · stroke 200mm, both ends cushioned, position of port (A) position of cushion needles (B).

①	Mounting type (SD·LB·FA·FB·CA·CB·CC·CD·TA·TC)
②	Cylinder bore mm (50·63·80·100·125·160·180·200·250)
③	Cushioning
	B Both ends cushioned
	R Head side cushioned
	H Cap side cushioned
N No cushion	
④	Cylinder stroke mm
⑤	Position of ports (A · B · C · D)
⑥	Position of cushion needles (A · B · C · D · O)

ORDER OUTLINE

1. The following are semi-standard.

- With boots
- TC position modification (dimension symbol PH)
- Piston rod end modification (dimension symbols W·WF·A·KK)

2. The standard position is (A) for ports and (B) for cushion needles. For positional modification, file the symbol mentioned in drawing of dimensional table.

For no cushion, the position of cushion needles is indicated as O.

(Symbols of port and cushion needle positions are filed clockwise as seen from rod side.)

10A-3 STRONG FORCE TYPE AIR CYLINDER

SECTIONAL DRAWINGS

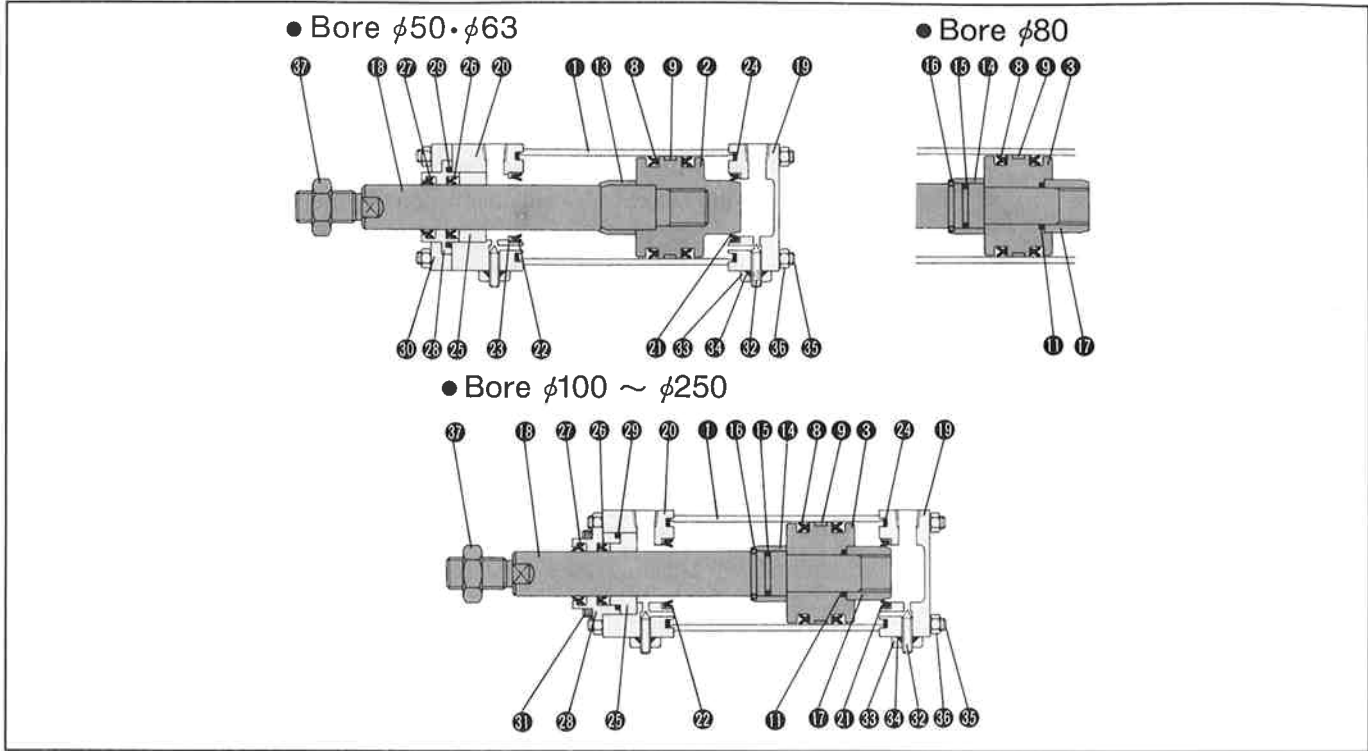

PARTS LIST

No.	Name	Material	Q'ty
1	Cylinder body	Carbon steel tube	1
2	Piston (φ50 · φ63)	Carbon steel	1
3	Piston (φ80~φ250)	Carbon steel	1
8	Piston seal	Nitrile rubber	2
9	Wear ring	Synthetic resin	1/2max. φ125 2min. φ50
11	Piston rod O-ring	Nitrile rubber	1
18	Cushion ring (φ50·φ63)	Brass pipe	1
14	Cushion ring (φ80~φ250)	Rolled steel	1
15	Cushion ring O-ring	Nitrile rubber	1
16	Stop ring	Piano wire	1
17	Piston nut	Rolled steel	1
19	Piston rod	Carbon steel	1
19	Cap	Carbon steel (φ50~φ100) Rolled steel (φ125~φ250)	1
20	Head cover	Carbon steel (φ50~φ100) Rolled steel (φ125~φ250)	1
21	Cushion seal (cap)	Canned nitrile rubber	1
22	Cushion seal (head)	Canned nitrile rubber	1

No.	Name	Material	Q'ty
23	Back-up ring	Cold rolled steel plate	1
24	End seal	Nitrile rubber	2
25	Rod gland	Sintered oilless alloy (φ50~φ125) Oilless alloy (φ160~φ250)	1
26	Rod seal	Nitrile rubber	1
27	Dust wiper	Polyurethane rubber	1
28	Seal housing	Carbon steel (φ50~φ200) Rolled steel (φ250)	1
29	Seal housing O-ring	Nitrile rubber	1
30	Retainer	Carbon steel	1
31	Seal housing set screw	Chromium-molybdenum steel	4
32	Cushion needle	Chromium-molybdenum steel	2
33	Cushion lock nut	Rolled steel	2
34	Cushion needle seal	Fluoric resin	2
35	Tie rod	Carbon steel	4
36	Tie rod nut	Rolled steel	8
37	Lock nut for rod end attachment	Carbon steel (φ50~φ200) Rolled steel (φ250)	1

SEAL LIST

Name	8	11	15	21	22	24	26	27	29	34
Q'ty	Piston seal	Piston rod O-ring	Cushion ring O-ring	Cushion seal (cap)	Cushion seal (head)	End seal	Rod seal	Dust wiper	Seal housing O-ring	Cushion needle seal
Bore (mm)	2	1	1	1	1	2	1	1	1	2
φ 50	PNU-40	—	—	PCS-28	PCS-28	TX-50	PNU-22	DA-22	N-38	SF-6
φ 63	PNU-53	—	—	PCS-28	PCS-28	TX-63	PNU-22	DA-22	N-38	SF-8
φ 80	PNU-70	P-21	P-21	PCS-35	PCS-40	TX-80	PNU-25A	DA-25	G-45	SF-8
φ100	PNU-90	P-28	P-26	PCS-40	PCS-45	TX-100	PNU-32	DA-32	G-45	SF-8
φ125	PNU-115	P-34	G-35	PCS-50	PCS-55	TX-125	PNU-40	DA-40	G-55	SF-8
φ160	PNU-145	G-40	G-45	PCS-60	PCS-65	TO-160	PNU-50	DA-50	G-65	SF-10
φ180	PNU-165	G-40	G-45	PCS-60	PCS-65	TO-180	PNU-50	DA-50	G-65	SF-10
φ200	PNU-185	G-40	G-45	PCS-60	PCS-65	TO-200	PNU-50	DA-50	G-65	SF-10
φ250	PNU-230	G-50	※G-58	PCS-65	PCS-75	TO-250	PNU-63	DA-63	G-80	SF-10

O-ring is JIS B2401-1A. But, * mark indicates Our Company's standard. When replacing seal, apply genuine **TAIYO** pneumatic equipment grease (20g / tube).

STRONG FORCE TYPE AIR CYLINDER 10A-3

DIMENSIONAL DRAWINGS / SD TYPE (BASIC TYPE)

Unit : mm

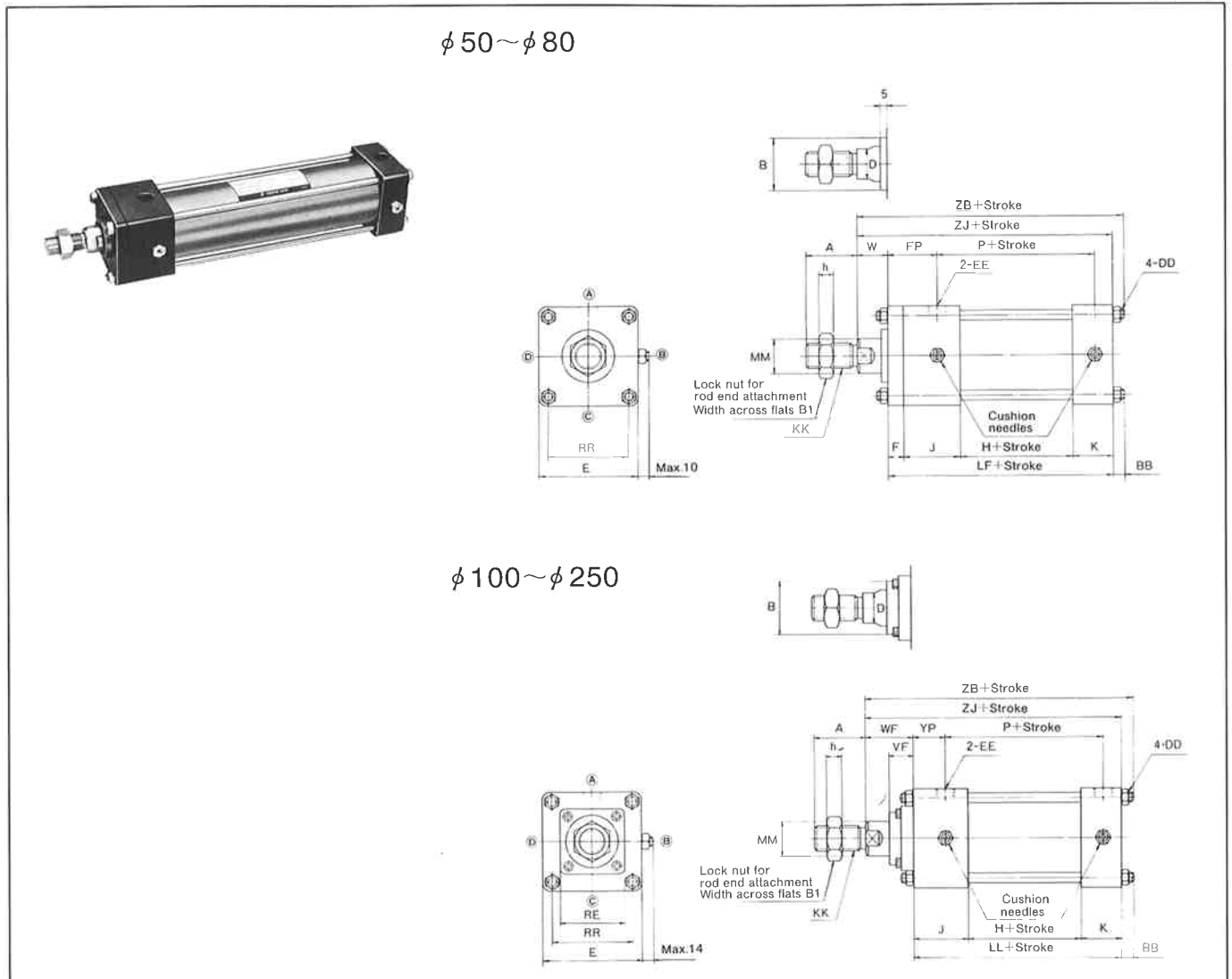

DIMENSIONAL TABLE

Symbol Bore	A	B	B ₁	BB	D	DD	E	EE	F	FP	H	h	J
$\phi 50$	36	$\phi 34$	24	7	19	M 6×1	□ 62	PT $\frac{1}{4}$	10	34	30	11	38
$\phi 63$	36	$\phi 34$	24	9	19	M 8×1.25	□ 76	PT $\frac{3}{8}$	10	34	33	11	38
$\phi 80$	44	$\phi 39$	30	10	22	M10×1.5	□ 94	PT $\frac{3}{8}$	16	43	31	13	45
$\phi 100$	54	$\phi 46$	36	10	27	M10×1.5	□114	PT $\frac{1}{2}$	—	—	31	16	45
$\phi 125$	72	$\phi 55$	50	13	36	M12×1.75	□138	PT $\frac{1}{2}$	—	—	37	20	45
$\phi 160$	84	$\phi 65$	60	16	46	M16×2	□178	PT $\frac{3}{4}$	—	—	43	22	50
$\phi 180$	84	$\phi 65$	60	16	46	M16×2	□200	PT $\frac{3}{4}$	—	—	43	22	50
$\phi 200$	84	$\phi 65$	60	16	46	M16×2	□216	PT $\frac{3}{4}$	—	—	43	22	50
$\phi 250$	112	$\phi 85$	80	19	55	M20×2.5	□270	PT1	—	—	55	30	57

Symbol Bore	K	KK	LF	LL	MM	P	RE	RR	VF	W	WF	YP	ZB	ZJ
$\phi 50$	25	M18×1.5	103	—	$\phi 22$	58	—	□ 47	—	15	—	—	125	118
$\phi 63$	25	M18×1.5	106	—	$\phi 22$	61	—	□ 56	—	15	—	—	130	121
$\phi 80$	32	M22×1.5	124	—	$\phi 25$	67	—	□ 70	—	19	—	—	153	143
$\phi 100$	32	M27×2	—	108	$\phi 32$	67	□ 65	□ 84	21	—	37	27	155	145
$\phi 125$	32	M36×2	—	114	$\phi 40$	73	□ 76	□104	25	—	43	27	170	157
$\phi 160$	38	M42×2	—	131	$\phi 50$	85	□ 94	□134	30	—	52	29	199	183
$\phi 180$	38	M42×2	—	131	$\phi 50$	85	□ 94	□156	30	—	52	29	199	183
$\phi 200$	38	M42×2	—	131	$\phi 50$	85	□ 94	□163	30	—	52	29	199	183
$\phi 250$	50	M56×2	—	162	$\phi 63$	109	□125	□202	33	—	60	30	241	222

10A-3 STRONG FORCE TYPE AIR CYLINDER

DIMENSIONAL DRAWINGS / LB TYPE (END ANGLES MOUNTING)

Unit : mm

$\phi 50 \sim \phi 80$

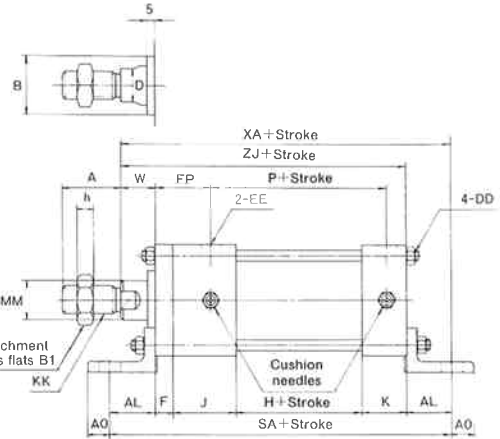
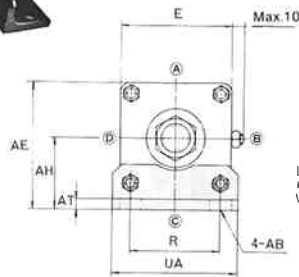

$\phi 100 \sim \phi 250$

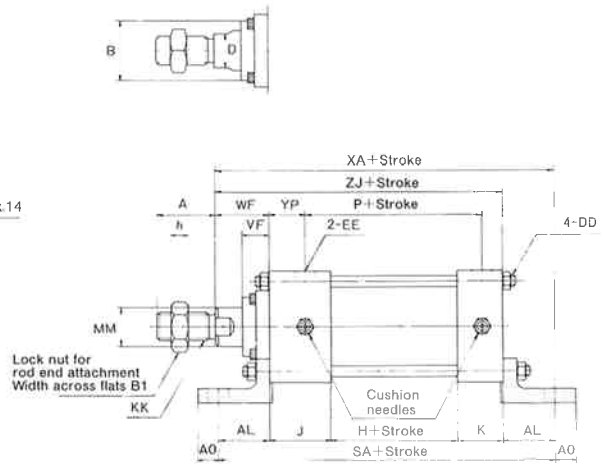
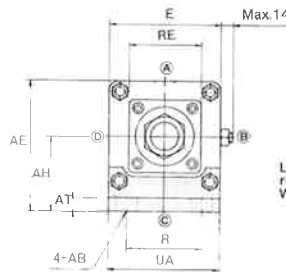

DIMENSIONAL TABLE

Symbol Bore	A	AB	AE	AH	AL	AO	AT	B	B ₁	D	DD	E	EE	F	FP	H
$\phi 50$	36	$\phi 12$	72	41	26	12	6	$\phi 34$	24	19	M 6×1	□ 62	PT $\frac{1}{4}$	10	34	30
$\phi 63$	36	$\phi 12$	86	48	28	12	6	$\phi 34$	24	19	M 8×1.25	□ 76	PT $\frac{3}{8}$	10	34	33
$\phi 80$	44	$\phi 14$	106	59	34	14	8	$\phi 39$	30	22	M10×1.5	□ 94	PT $\frac{3}{8}$	16	43	31
$\phi 100$	54	$\phi 14$	123	66	34	14	8	$\phi 46$	36	27	M10×1.5	□114	PT $\frac{1}{2}$	—	—	31
$\phi 125$	72	$\phi 18$	148	79	43	18	10	$\phi 55$	50	36	M12×1.75	□138	PT $\frac{1}{2}$	—	—	37
$\phi 160$	84	$\phi 22$	187	98	50	22	10	$\phi 65$	60	46	M16×2	□178	PT $\frac{3}{4}$	—	—	43
$\phi 180$	84	$\phi 22$	215	115	55	22	15	$\phi 65$	60	46	M16×2	□200	PT $\frac{3}{4}$	—	—	43
$\phi 200$	84	$\phi 22$	226	118	55	22	15	$\phi 65$	60	46	M16×2	□216	PT $\frac{3}{4}$	—	—	43
$\phi 250$	112	$\phi 26$	276	141	60	24	15	$\phi 85$	80	55	M20×2.5	□270	PT1	—	—	55

Symbol Bore	h	J	K	KK	MM	P	R	RE	SA	UA	VF	W	WF	XA	YP	ZJ
$\phi 50$	11	38	25	M18×1.5	$\phi 22$	58	47	—	155	70	—	15	—	144	—	118
$\phi 63$	11	38	25	M18×1.5	$\phi 22$	61	56	—	162	80	—	15	—	149	—	121
$\phi 80$	13	45	32	M22×1.5	$\phi 25$	67	70	—	192	97	—	19	—	177	—	143
$\phi 100$	16	45	32	M27×2	$\phi 32$	67	84	□ 65	176	114	21	—	37	179	27	145
$\phi 125$	20	45	32	M36×2	$\phi 40$	73	104	□ 76	200	138	25	—	43	200	27	157
$\phi 160$	22	50	38	M42×2	$\phi 50$	85	134	□ 94	231	178	30	—	52	233	29	183
$\phi 180$	22	50	38	M42×2	$\phi 50$	85	156	□ 94	241	200	30	—	52	238	29	183
$\phi 200$	22	50	38	M42×2	$\phi 50$	85	163	□ 94	241	216	30	—	52	238	29	183
$\phi 250$	30	57	50	M56×2	$\phi 63$	109	202	□125	282	270	33	—	60	282	30	222

STRONG FORCE TYPE AIR CYLINDER **10A-3**

DIMENSIONAL DRAWINGS / FA TYPE (HEAD FLANGE MOUNTING)

Unit: mm

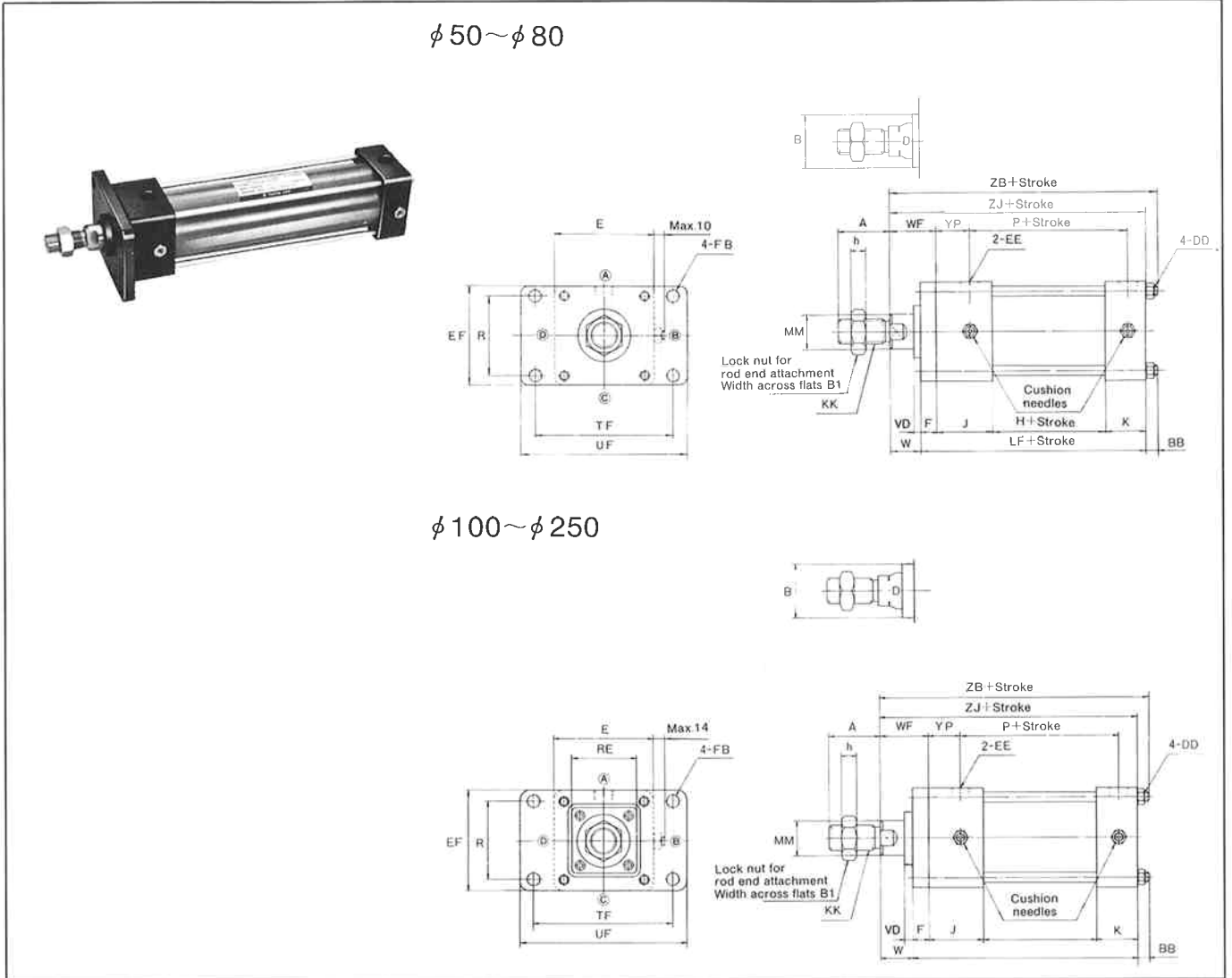

DIMENSIONAL TABLE

Symbol Bore	A	B	B ₁	BB	D	DD	E	EE	EF	F	FB	H	h	J
$\phi 50$	36	$\phi 34$	24	7	19	M 6×1	□ 62	PT $\frac{1}{4}$	65	10	$\phi 9$	30	11	38
$\phi 63$	36	$\phi 34$	24	9	19	M 8×1.25	□ 76	PT $\frac{3}{8}$	76	10	$\phi 9$	33	11	38
$\phi 80$	44	$\phi 39$	30	10	22	M10×1.5	□ 94	PT $\frac{3}{8}$	95	16	$\phi 12$	31	13	45
$\phi 100$	54	$\phi 46$	36	10	27	M10×1.5	□ 114	PT $\frac{1}{2}$	115	16	$\phi 12$	31	16	45
$\phi 125$	72	$\phi 55$	50	13	36	M12×1.75	□ 138	PT $\frac{1}{2}$	138	16	$\phi 14$	37	20	45
$\phi 160$	84	$\phi 65$	60	16	46	M16×2	□ 178	PT $\frac{3}{4}$	178	20	$\phi 18$	43	22	50
$\phi 180$	84	$\phi 65$	60	16	46	M16×2	□ 200	PT $\frac{3}{4}$	200	20	$\phi 18$	43	22	50
$\phi 200$	84	$\phi 65$	60	16	46	M16×2	□ 216	PT $\frac{3}{4}$	216	20	$\phi 18$	43	22	50
$\phi 250$	112	$\phi 85$	80	19	55	M20×2.5	□ 270	PT1	270	25	$\phi 22$	55	30	57

Symbol Bore	K	KK	LF	MM	P	R	RE	TF	UF	VD	W	WF	YP	ZB	ZJ
$\phi 50$	25	M18×1.5	103	$\phi 22$	58	47	—	86	104	5	15	25	24	125	118
$\phi 63$	25	M18×1.5	106	$\phi 22$	61	56	—	98	116	5	15	25	24	130	121
$\phi 80$	32	M22×1.5	124	$\phi 25$	67	70	—	119	143	5	19	35	27	153	143
$\phi 100$	32	M27×2	124	$\phi 32$	67	84	□ 65	138	162	5	21	37	27	155	145
$\phi 125$	32	M36×2	130	$\phi 40$	73	104	□ 76	168	196	9	27	43	27	170	157
$\phi 160$	38	M42×2	151	$\phi 50$	85	134	□ 94	212	248	10	32	52	29	199	183
$\phi 180$	38	M42×2	151	$\phi 50$	85	156	□ 94	234	270	10	32	52	29	199	183
$\phi 200$	38	M42×2	151	$\phi 50$	85	163	□ 94	250	286	10	32	52	29	199	183
$\phi 250$	50	M56×2	187	$\phi 63$	109	201	□ 125	312	356	8	35	60	30	241	222

10A-3 STRONG FORCE TYPE AIR CYLINDER

DIMENSIONAL DRAWINGS / FB TYPE (CAP FLANGE MOUNTING)

Unit : mm

$\phi 50 \sim \phi 80$

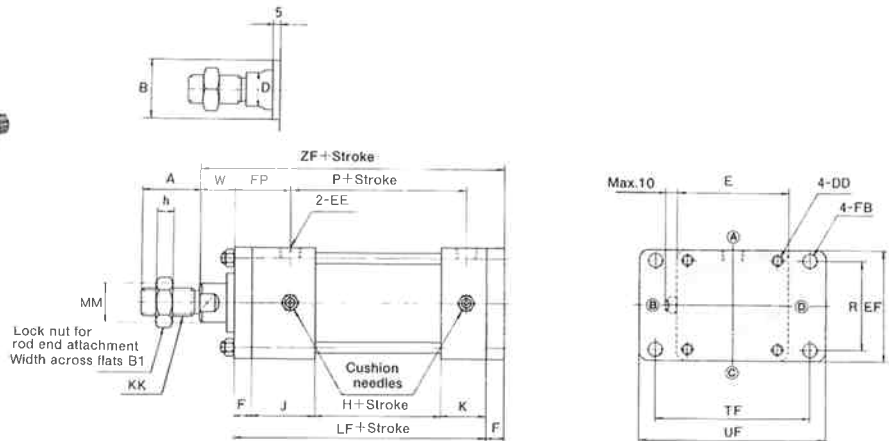

$\phi 100 \sim \phi 250$

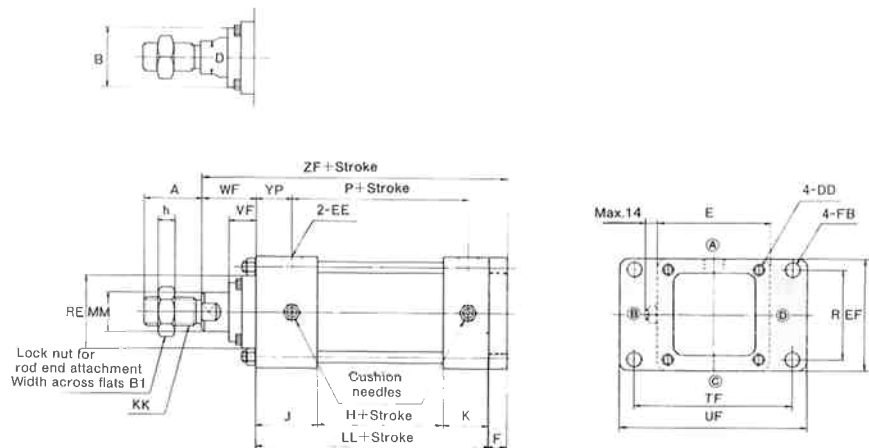

DIMENSIONAL TABLE

Bore	Symbol	A	B	B ₁	D	DD	E	EE	EF	F	FB	FP	H	h	J	
$\phi 50$		36	$\phi 34$	24	19	M 6×1	□ 62	PT $\frac{1}{4}$	65	10	$\phi 9$	34	30	11	38	
$\phi 63$		36	$\phi 34$	24	19	M 8×1.25	□ 76	PT $\frac{3}{8}$	76	10	$\phi 9$	34	33	11	38	
$\phi 80$		44	$\phi 39$	30	22	M10×1.5	□ 94	PT $\frac{3}{8}$	95	16	$\phi 12$	43	31	13	45	
$\phi 100$		54	$\phi 46$	36	27	M10×1.5	□ 114	PT $\frac{1}{2}$	115	16	$\phi 12$	—	31	16	45	
$\phi 125$		72	$\phi 55$	50	36	M12×1.75	□ 138	PT $\frac{1}{2}$	138	16	$\phi 14$	—	37	20	45	
$\phi 160$		84	$\phi 65$	60	46	M16×2	□ 178	PT $\frac{1}{4}$	178	20	$\phi 18$	—	43	22	50	
$\phi 180$		84	$\phi 65$	60	46	M16×2	□ 200	PT $\frac{3}{4}$	200	20	$\phi 18$	—	43	22	50	
$\phi 200$		84	$\phi 65$	60	46	M16×2	□ 216	PT $\frac{3}{4}$	216	20	$\phi 18$	—	43	22	50	
$\phi 250$		112	$\phi 85$	80	55	M20×2.5	□ 270	PT1	270	25	$\phi 22$	—	55	30	57	
Bore	Symbol	K	KK	LF	LL	MM	P	R	RE	TF	UF	VF	W	WF	YP	ZF
$\phi 50$		25	M18×1.5	103	—	$\phi 22$	58	47	—	86	104	—	15	—	—	128
$\phi 63$		25	M18×1.5	106	—	$\phi 22$	61	56	—	98	116	—	15	—	—	131
$\phi 80$		32	M22×1.5	124	—	$\phi 25$	67	70	—	119	143	—	19	—	—	159
$\phi 100$		32	M27×2	—	108	$\phi 32$	67	84	□ 65	138	162	21	—	37	27	161
$\phi 125$		32	M36×2	—	114	$\phi 40$	73	104	□ 76	168	196	25	—	43	27	173
$\phi 160$		38	M42×2	—	131	$\phi 50$	85	134	□ 94	212	248	30	—	52	29	203
$\phi 180$		38	M42×2	—	131	$\phi 50$	85	156	□ 94	234	270	30	—	52	29	203
$\phi 200$		38	M42×2	—	131	$\phi 50$	85	163	□ 94	250	286	30	—	52	29	203
$\phi 250$		50	M56×2	—	162	$\phi 63$	109	201	□ 125	312	356	33	—	60	30	247

STRONG FORCE TYPE AIR CYLINDER **10A-3**

DIMENSIONAL DRAWINGS / CA TYPE (CAP EYE MOUNTING) · CC TYPE (φ125~φ250) Unit: mm

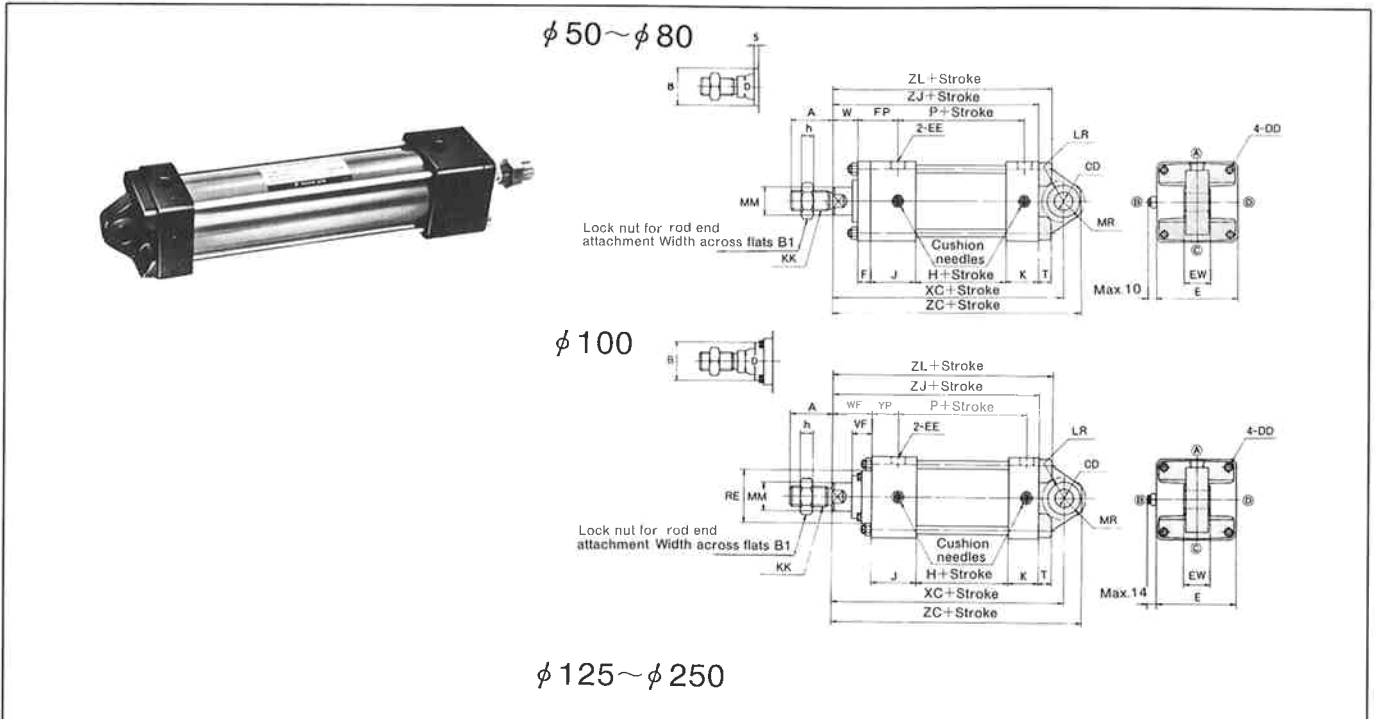

● CA Type (Fittings Welding Type)

● CC Type (Fittings Separate Type)

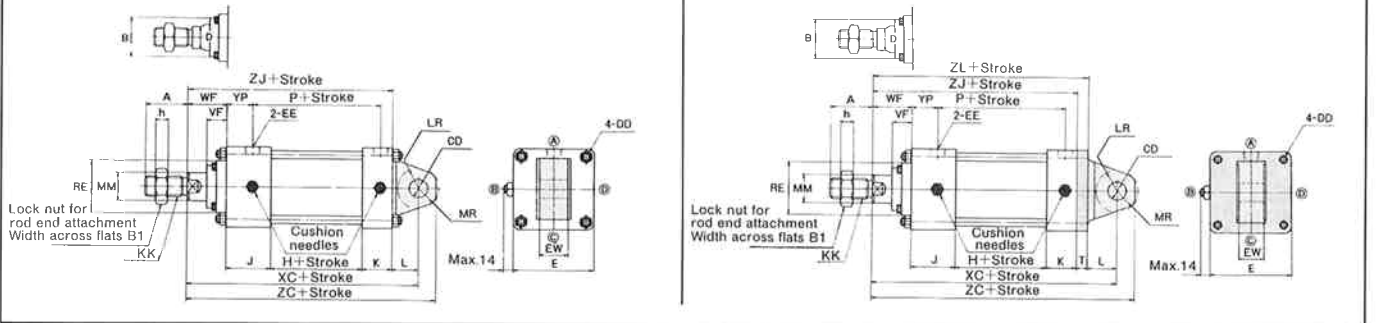

DIMENSIONAL TABLE

Symbol Bore	A	B	B ₁	CD	D	DD	E	EE	EW	F	FP	H	h	J	K	KK
φ 50	36	φ 34	24	φ 14H9	19	M 6×1	□ 62	PT ¹ / ₄	20 ⁰ _{-0.084}	10	34	30	11	38	25	M18×1.5
φ 63	36	φ 34	24	φ 14H9	19	M 8×1.25	□ 76	PT ³ / ₈	20 ⁰ _{-0.084}	10	34	33	11	38	25	M18×1.5
φ 80	44	φ 39	30	φ 20H9	22	M10×1.5	□ 94	PT ³ / ₈	32 ⁰ _{-0.100}	16	43	31	13	45	32	M22×1.5
φ 100	54	φ 46	36	φ 20H9	27	M10×1.5	□ 114	PT ¹ / ₂	32 ⁰ _{-0.100}	—	—	31	16	45	32	M27×2
φ 125	72	φ 55	50	φ 20H9	36	M12×1.75	□ 138	PT ¹ / ₂	32 ⁰ _{-0.100}	—	—	37	20	45	32	M36×2
φ 160	84	φ 65	60	φ 28H9	46	M16×2	□ 178	PT ³ / ₄	40 ⁰ _{-0.100}	—	—	43	22	50	38	M42×2
φ 180	84	φ 65	60	φ 28H9	46	M16×2	□ 200	PT ³ / ₄	40 ⁰ _{-0.100}	—	—	43	22	50	38	M42×2
φ 200	84	φ 65	60	φ 28H9	46	M16×2	□ 216	PT ³ / ₄	40 ⁰ _{-0.100}	—	—	43	22	50	38	M42×2
φ 250	112	φ 85	80	φ 36H9	55	M20×2.5	□ 270	PT1	50 ⁰ _{-0.100}	—	—	55	30	57	50	M56×2

Symbol Bore	L		LR		MM	MR	P	RE	T	VF	W	WF	XC		YP	ZC		ZJ	ZL
	CA Type	CC Type	CA Type	CC Type									CA Type	CC Type		CA Type	CC Type		
φ 50	—	—	R19	—	φ 22	R16	58	—	10	—	15	—	137	—	—	151	—	118	128
φ 63	—	—	R19	—	φ 22	R16	61	—	13	—	15	—	140	—	—	154	—	121	134
φ 80	—	—	R26	—	φ 25	R22	67	—	18	—	19	—	175	—	—	195	—	143	161
φ 100	—	—	R27	—	φ 32	R22	67	□ 65	18	21	—	37	177	—	27	197	—	145	163
φ 125	32	36	R22	R26	φ 40	R22	73	□ 76	14	25	—	43	189	207	27	209	227	157	171
φ 160	38	44	R30	R32	φ 50	R30	85	□ 94	20	30	—	52	221	247	29	249	275	183	203
φ 180	38	44	R30	R32	φ 50	R30	85	□ 94	25	30	—	52	221	252	29	249	280	183	208
φ 200	38	44	R30	R32	φ 50	R30	85	□ 94	25	30	—	52	221	252	29	249	280	183	208
φ 250	54	58	R42	R46	φ 63	R42	109	□ 125	30	33	—	60	276	310	30	312	346	222	252

10A-3 STRONG FORCE TYPE AIR CYLINDER

DIMENSIONAL DRAWINGS / CB TYPE (CAP CLEVIS MOUNTING) WITH PIN · CD TYPE WITH PIN ($\phi 125 \sim \phi 250$)

Unit : mm

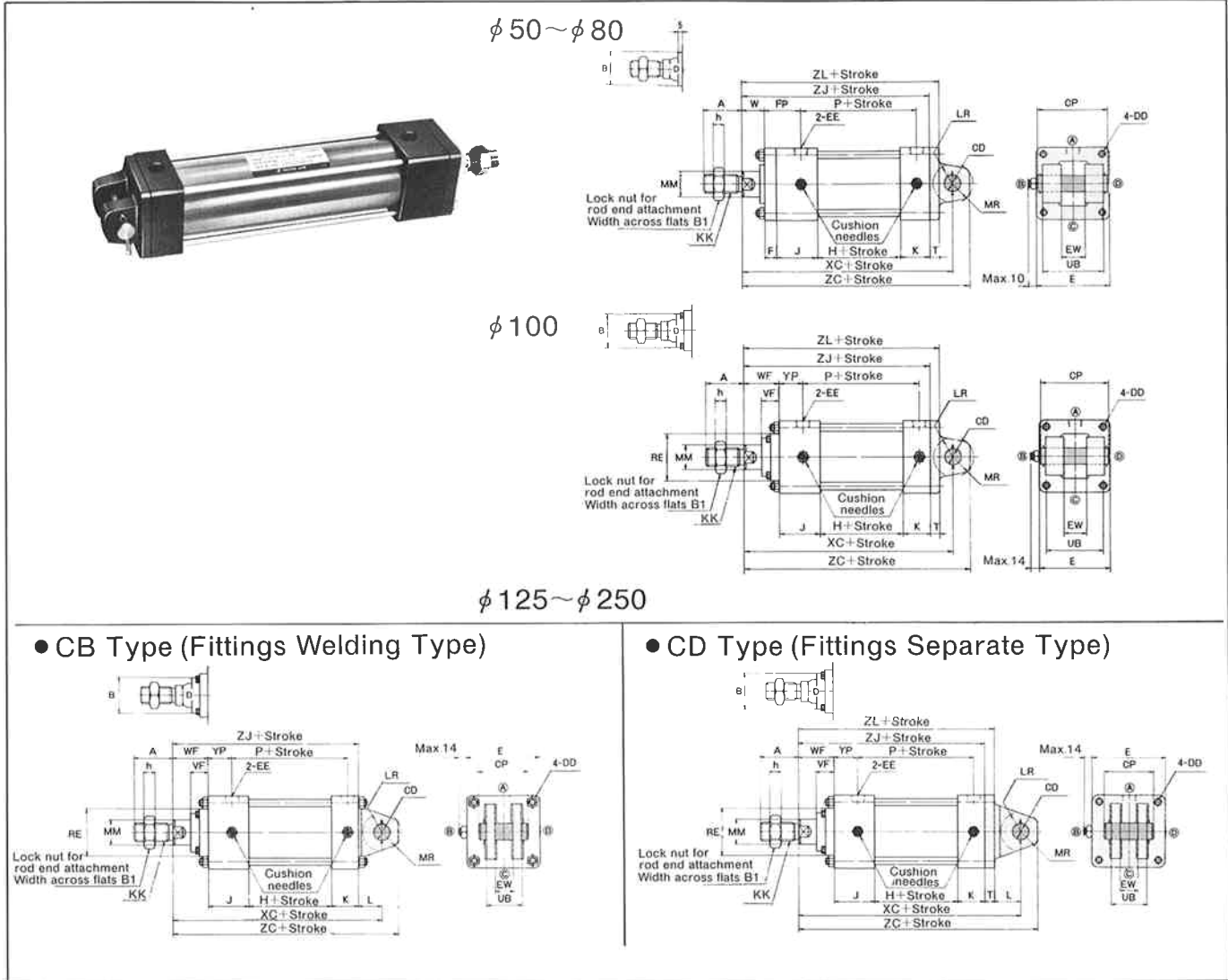

DIMENSIONAL TABLE

Symbol Bore	A	B	B ₁	CD	CP	D	DD	E	EE	EW	F	FP	H	h	J	K	KK
	$\phi 50$	36	$\phi 34$	24	$\phi 14 \frac{H9}{f8}$	66	19	M6 × 1	□ 62	PT $\frac{1}{4}$	20 $^{+0.7}_{-0.5}$	10	34	30	11	38	25
$\phi 63$	36	$\phi 34$	24	$\phi 14 \frac{H9}{f8}$	66	19	M8 × 1.25	□ 76	PT $\frac{3}{8}$	20 $^{+0.7}_{-0.5}$	10	34	33	11	38	25	M18 × 1.5
$\phi 80$	44	$\phi 39$	30	$\phi 20 \frac{H9}{f8}$	78	22	M10 × 1.5	□ 94	PT $\frac{3}{8}$	32 $^{+0.7}_{-0.5}$	16	43	31	13	45	32	M22 × 1.5
$\phi 100$	54	$\phi 46$	36	$\phi 20 \frac{H9}{f8}$	78	27	M10 × 1.5	□ 114	PT $\frac{1}{2}$	32 $^{+0.7}_{-0.5}$	—	—	31	16	45	32	M27 × 2
$\phi 125$	72	$\phi 55$	50	$\phi 20 \frac{H9}{f8}$	78	36	M12 × 1.75	□ 138	PT $\frac{1}{2}$	32 $^{+0.7}_{-0.5}$	—	—	37	20	45	32	M36 × 2
$\phi 160$	84	$\phi 65$	60	$\phi 28 \frac{H9}{f8}$	97	46	M16 × 2	□ 178	PT $\frac{3}{4}$	40 $^{+0.8}_{-0.5}$	—	—	43	22	50	38	M42 × 2
$\phi 180$	84	$\phi 65$	60	$\phi 28 \frac{H9}{f8}$	97	46	M16 × 2	□ 200	PT $\frac{3}{4}$	40 $^{+0.8}_{-0.5}$	—	—	43	22	50	38	M42 × 2
$\phi 200$	84	$\phi 65$	60	$\phi 28 \frac{H9}{f8}$	97	46	M16 × 2	□ 216	PT $\frac{3}{4}$	40 $^{+0.8}_{-0.5}$	—	—	43	22	50	38	M42 × 2
$\phi 250$	112	$\phi 85$	80	$\phi 36 \frac{H9}{f8}$	117	55	M20 × 2.5	□ 270	PT1	50 $^{+0.8}_{-0.5}$	—	—	55	30	57	50	M56 × 2

Symbol Bore	L	CB Type	CD Type	XC										ZC		ZJ	ZL			
				LR	MM	MR	P	RE	T	UB	VF	W	WF	CB Type	CD Type			YP	CB Type	CD Type
$\phi 50$	—	—	—	R19	$\phi 22$	R17	58	—	8	52	—	15	—	137	—	—	152	—	118	126
$\phi 63$	—	—	—	R19	$\phi 22$	R17	61	—	8	52	—	15	—	140	—	—	155	—	121	129
$\phi 80$	—	—	—	R32	$\phi 25$	R23	67	—	11	64	—	19	—	175	—	—	196	—	143	154
$\phi 100$	—	—	—	R32	$\phi 32$	R23	67	□ 65	11	64	21	—	37	177	—	27	198	—	145	156
$\phi 125$	32	36	—	R26	$\phi 40$	R22	73	□ 76	14	64	25	—	43	189	207	27	209	227	157	171
$\phi 160$	38	44	—	R32	$\phi 50$	R30	85	□ 94	20	80	30	—	52	221	247	29	249	275	183	203
$\phi 180$	38	44	—	R32	$\phi 50$	R30	85	□ 94	25	80	30	—	52	221	252	29	249	280	183	208
$\phi 200$	38	44	—	R32	$\phi 50$	R30	85	□ 94	25	80	30	—	52	221	252	29	249	280	183	208
$\phi 250$	54	58	—	R46	$\phi 63$	R42	109	□ 125	30	100	33	—	60	276	310	30	312	346	222	252

STRONG FORCE TYPE AIR CYLINDER 10A-3

DIMENSIONAL DRAWINGS / TA TYPE (HEAD TRUNNION MOUNTING)

Unit : mm

$\phi 50 \sim \phi 80$

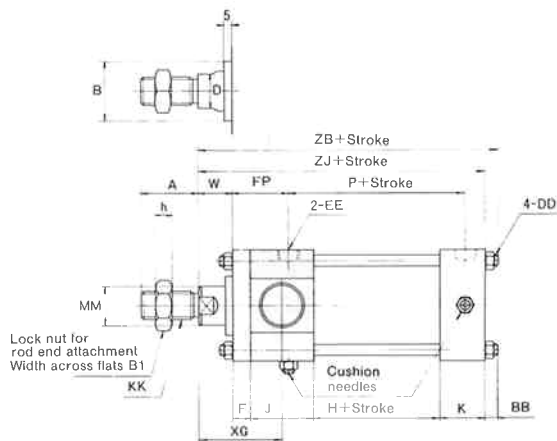
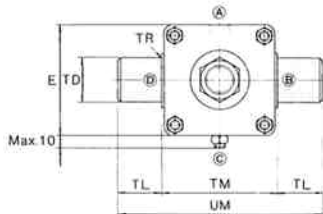

$\phi 100 \sim \phi 250$

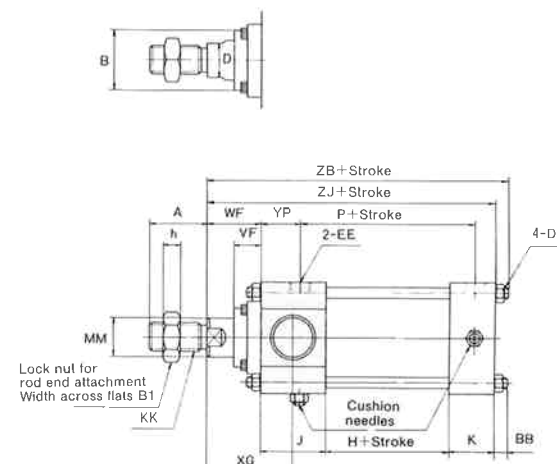
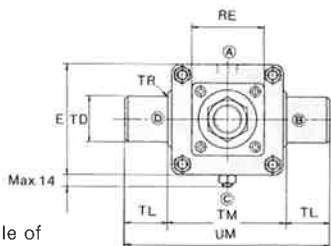

• For TA type, the position of cushion needle of head cover is structurally set at ©.

DIMENSIONAL TABLE

Symbol Bore	A	B	B ₁	BB	D	DD	E	EE	F	FP	H	h	J	K
$\phi 50$	36	$\phi 34$	24	7	19	M 6×1	□ 62	PT $\frac{1}{4}$	10	34	30	11	38	25
$\phi 63$	36	$\phi 34$	24	9	19	M 8×1.25	□ 76	PT $\frac{3}{8}$	10	34	33	11	38	25
$\phi 80$	44	$\phi 39$	30	10	22	M10×1.5	□ 94	PT $\frac{3}{8}$	16	43	31	13	45	32
$\phi 100$	54	$\phi 46$	36	10	27	M10×1.5	□114	PT $\frac{1}{2}$	—	—	31	16	45	32
$\phi 125$	72	$\phi 55$	50	13	36	M12×1.75	□138	PT $\frac{1}{2}$	—	—	37	20	45	32
$\phi 160$	84	$\phi 65$	60	16	46	M16×2	□178	PT $\frac{3}{4}$	—	—	43	22	50	38
$\phi 180$	84	$\phi 65$	60	16	46	M16×2	□200	PT $\frac{3}{4}$	—	—	43	22	50	38
$\phi 200$	84	$\phi 65$	60	16	46	M16×2	□216	PT $\frac{3}{4}$	—	—	43	22	50	38
$\phi 250$	112	$\phi 85$	80	19	55	M20×2.5	□270	PT1	—	—	55	30	57	50

Symbol Bore	KK	MM	P	RE	TD	TL	TM	TR	UM	VF	W	WF	XG	YP	ZB	ZJ
$\phi 50$	M18×1.5	$\phi 22$	58	—	$\phi 25e9$	25	63	R1.6	113	—	15	—	44	—	125	118
$\phi 63$	M18×1.5	$\phi 22$	61	—	$\phi 25e9$	25	76	R1.6	126	—	15	—	44	—	130	121
$\phi 80$	M22×1.5	$\phi 25$	67	—	$\phi 25e9$	25	95	R1.6	145	—	19	—	57	—	153	143
$\phi 100$	M27×2	$\phi 32$	67	□ 65	$\phi 25e9$	25	114	R2	164	21	—	37	59	27	155	145
$\phi 125$	M36×2	$\phi 40$	73	□ 76	$\phi 25e9$	25	139	R2	189	25	—	43	65	27	170	157
$\phi 160$	M42×2	$\phi 50$	85	□ 94	$\phi 36e9$	36	178	R2.5	250	30	—	52	77	29	199	183
$\phi 180$	M42×2	$\phi 50$	85	□ 94	$\phi 36e9$	36	200	R2.5	272	30	—	52	77	29	199	183
$\phi 200$	M42×2	$\phi 50$	85	□ 94	$\phi 36e9$	36	216	R2.5	288	30	—	52	77	29	199	183
$\phi 250$	M56×2	$\phi 63$	109	□125	$\phi 45e9$	45	270	R3	360	33	—	60	88	30	241	222

10A-3 STRONG FORCE TYPE AIR CYLINDER

DIMENSIONAL DRAWINGS / TC TYPE (INTERMEDIATE TRUNNION MOUNTING)

Unit: mm

$\phi 50 \sim \phi 80$

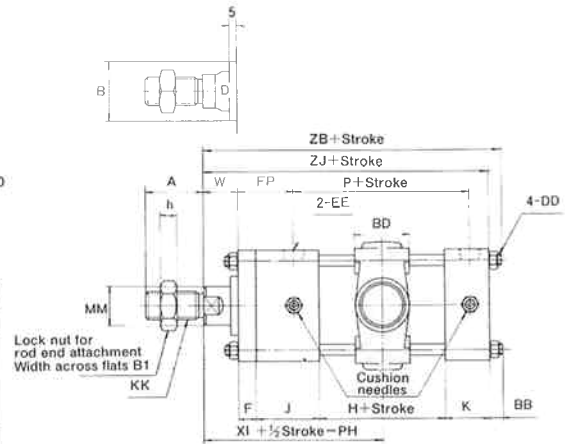
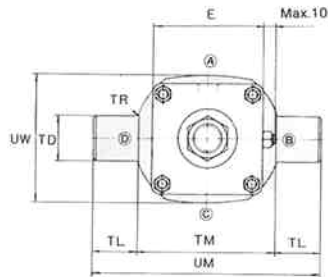

$\phi 100 \sim \phi 250$

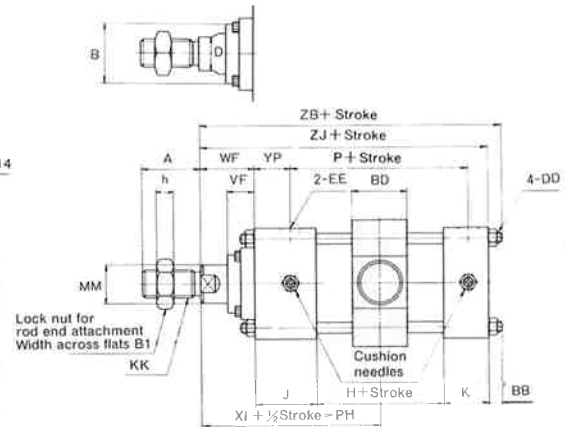
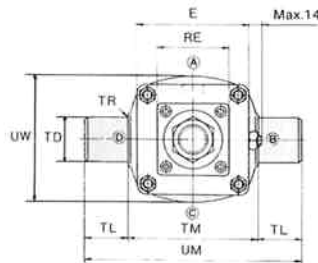

DIMENSIONAL TABLE

Symbol Bore	A	B	B ₁	BB	BD	D	DD	E	EE	F	FP	H	h	J	K	KK	MM
$\phi 50$	36	$\phi 34$	24	7	30	19	M 6×1	□ 62	PT $\frac{1}{4}$	10	34	30	11	38	25	M18×1.5	$\phi 22$
$\phi 63$	36	$\phi 34$	24	9	30	19	M 8×1.25	□ 76	PT $\frac{3}{8}$	10	34	33	11	38	25	M18×1.5	$\phi 22$
$\phi 80$	44	$\phi 39$	30	10	35	22	M10×1.5	□ 94	PT $\frac{3}{8}$	16	43	31	13	45	32	M22×1.5	$\phi 25$
$\phi 100$	54	$\phi 46$	36	10	40	27	M10×1.5	□ 114	PT $\frac{1}{2}$	—	—	31	16	45	32	M27×2	$\phi 32$
$\phi 125$	72	$\phi 55$	50	13	43	36	M12×1.75	□ 138	PT $\frac{1}{2}$	—	—	37	20	45	32	M36×2	$\phi 40$
$\phi 160$	84	$\phi 65$	60	16	53	46	M16×2	□ 178	PT $\frac{3}{4}$	—	—	43	22	50	38	M42×2	$\phi 50$
$\phi 180$	84	$\phi 65$	60	16	53	46	M16×2	□ 200	PT $\frac{3}{4}$	—	—	43	22	50	38	M42×2	$\phi 50$
$\phi 200$	84	$\phi 65$	60	16	53	46	M16×2	□ 216	PT $\frac{3}{4}$	—	—	43	22	50	38	M42×2	$\phi 50$
$\phi 250$	112	$\phi 85$	80	19	58	55	M20×2.5	□ 270	PT1	—	—	55	30	57	50	M56×2	$\phi 63$

Symbol Bore	P	Min. PH	Min. stroke	RE	TD	TL	TM	TR	UM	UW	VF	W	WF	XI	YP	ZB	ZJ
$\phi 50$	58	78	3	—	$\phi 25e9$	25	76	R1.6	126	71	—	15	—	78	—	125	118
$\phi 63$	61	78	0	—	$\phi 25e9$	25	88	R1.6	138	86	—	15	—	79.5	—	130	121
$\phi 80$	67	98	7	—	$\phi 25e9$	25	114	R1.6	164	104	—	19	—	95.5	—	153	143
$\phi 100$	67	102	12	□ 65	$\phi 25e9$	25	132	R2	182	128	21	—	37	97.5	27	155	145
$\phi 125$	73	110	9	□ 76	$\phi 25e9$	25	158	R2	208	158	25	—	43	106.5	27	170	157
$\phi 160$	85	129	13	□ 94	$\phi 36e9$	36	200	R2.5	272	200	30	—	52	123.5	29	199	183
$\phi 180$	85	129	13	□ 94	$\phi 36e9$	36	228	R2.5	300	228	30	—	52	123.5	29	199	183
$\phi 200$	85	129	13	□ 94	$\phi 36e9$	36	246	R2.5	318	246	30	—	52	123.5	29	199	183
$\phi 250$	109	146	6	□ 125	$\phi 45e9$	45	304	R3	394	304	33	—	60	144.5	30	241	222

STRONG FORCE TYPE AIR CYLINDER 10A-3

ACCESSORIES

Unit : mm

WITH BOOT

$\phi 50 \sim \phi 80$

$\phi 100 \sim \phi 250$

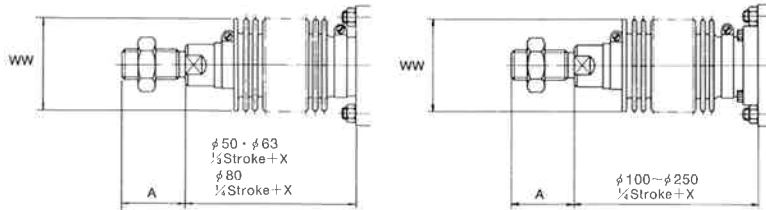

DIMENSIONAL TABLE

Bore	Symbol	A	X	WW
$\phi 50$		36	55	$\phi 45$
$\phi 63$		36	55	$\phi 45$
$\phi 80$		44	65	$\phi 60$
$\phi 100$		54	73	$\phi 71$
$\phi 125$		72	75	$\phi 80$
$\phi 160$		84	85	$\phi 100$
$\phi 180$		84	85	$\phi 100$
$\phi 200$		84	85	$\phi 100$
$\phi 250$		112	90	$\phi 125$

Note : Minor fraction shall be raised to unit.
As for with boot, seal housing for $\phi 50 \sim \phi 80$ differs from standard.

	Standard	Semi-standard
Material	Nylon tarpaulin	Neoprene
Heat proof	80°C	130°C

Note : Dimension differs for Almix.

ROD END EYE (T TYPE)

$\phi 50 \sim \phi 80$

$\phi 125$

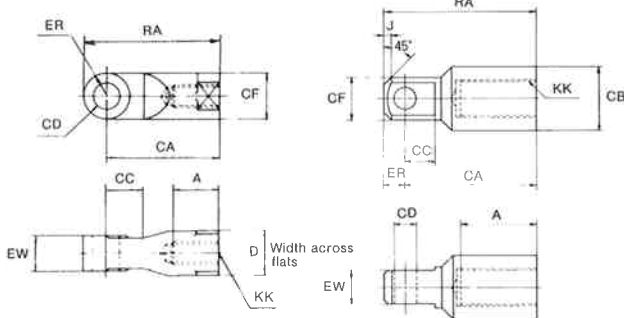

$\phi 100 \cdot \phi 160 \sim \phi 250$

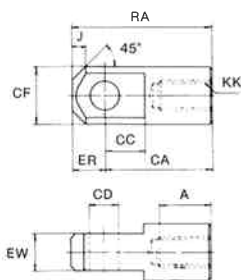

ROD END CLEVIS (Y TYPE) WITH PIN

$\phi 50 \sim \phi 80$

$\phi 100 \cdot \phi 250$

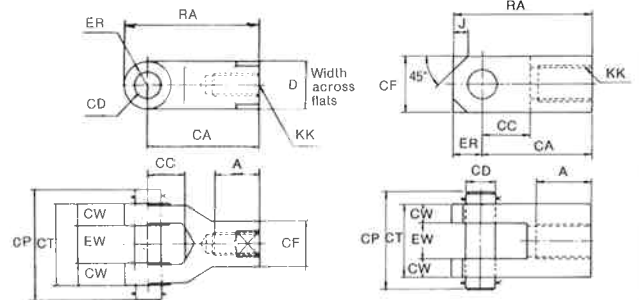

$\phi 125 \sim \phi 200$

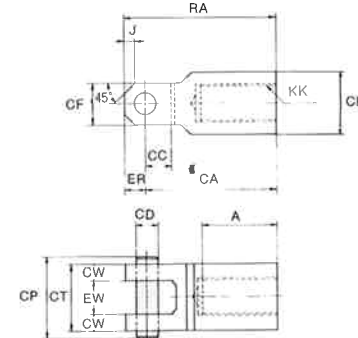

DIMENSIONAL TABLE

Symbol Bore	A	CA	CB	CC	CD	CF	D	ER	EW	J	KK	RA
$\phi 50$	37	64	-	18	$\phi 14H9$	$\phi 28$	30	R14	$20_{-0.1}^0$	-	M18×1.5	78
$\phi 63$	37	64	-	18	$\phi 14H9$	$\phi 28$	30	R14	$20_{-0.1}^0$	-	M18×1.5	78
$\phi 80$	45	100	-	30	$\phi 20H9$	$\phi 38$	41	R19	$32_{-0.1}^0$	-	M22×1.5	119
$\phi 100$	54	108	-	28	$\phi 20H9$	$\phi 49$	-	19	$32_{-0.1}^0$	10	M27×2	127
$\phi 125$	72	125	$\phi 62$	32	$\phi 20H9$	$\phi 49$	-	20	$32_{-0.1}^0$	13	M36×2	145
$\phi 160$	84	140	-	33	$\phi 28H9$	$\phi 62$	-	28	$40_{-0.1}^0$	18	M42×2	168
$\phi 180$	84	140	-	33	$\phi 28H9$	$\phi 62$	-	28	$40_{-0.1}^0$	18	M42×2	168
$\phi 200$	84	140	-	33	$\phi 28H9$	$\phi 62$	-	28	$40_{-0.1}^0$	18	M42×2	168
$\phi 250$	110	188	-	48	$\phi 36H9$	$\phi 79$	-	36	$50_{-0.1}^0$	20	M56×2	224

DIMENSIONAL TABLE

Symbol Bore	A	CA	CB	CC	CD	CF	CP	CT	CW	D	ER	EW	J	KK	RA
$\phi 50$	37	64	-	18	$\phi 14_{-0.018}^{+0.014}$	$\phi 28$	58	44	12	30	R14	$20_{-0.05}^{+1.5}$	-	M18×1.5	78
$\phi 63$	37	64	-	18	$\phi 14_{-0.018}^{+0.014}$	$\phi 28$	58	44	12	30	R14	$20_{-0.05}^{+1.5}$	-	M18×1.5	78
$\phi 80$	45	100	-	28	$\phi 20_{-0.018}^{+0.014}$	$\phi 38$	78	64	16	41	R19	$32_{-0.05}^{+1.5}$	-	M22×1.5	119
$\phi 100$	54	108	-	28	$\phi 20_{-0.018}^{+0.014}$	$\phi 49$	40	78	64	16	-	$32_{-0.05}^{+1.5}$	10	M27×2	127
$\phi 125$	72	125	60	32	$\phi 20_{-0.018}^{+0.014}$	$\phi 49$	40	78	64	16	-	$32_{-0.05}^{+1.5}$	10	M36×2	145
$\phi 160$	84	140	60	33	$\phi 28_{-0.018}^{+0.014}$	$\phi 62$	54	97	80	20	-	$40_{-0.05}^{+1.5}$	16	M42×2	168
$\phi 180$	84	140	60	33	$\phi 28_{-0.018}^{+0.014}$	$\phi 62$	54	97	80	20	-	$40_{-0.05}^{+1.5}$	16	M42×2	168
$\phi 200$	84	140	60	33	$\phi 28_{-0.018}^{+0.014}$	$\phi 62$	54	97	80	20	-	$40_{-0.05}^{+1.5}$	16	M42×2	168
$\phi 250$	110	188	-	48	$\phi 36_{-0.018}^{+0.014}$	$\phi 79$	80	117	100	25	-	$50_{-0.05}^{+1.5}$	23	M56×2	224

10A-3 STRONG FORCE TYPE AIR CYLINDER

ACCESSORIES

Unit : mm

BRACKET FOR CB/CD $\phi 50 \sim \phi 80$

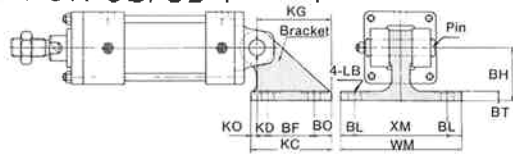

$\phi 100$

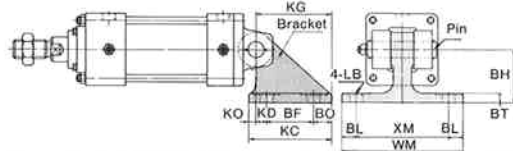

$\phi 125 \sim \phi 250$

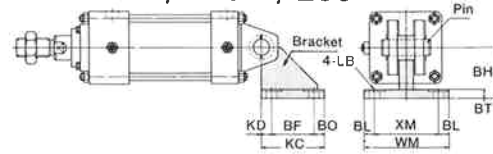

• Refer to CB·CD types for the dimension of cylinder body.

DIMENSIONAL TABLE

Symbol Bore	BF	BH	BL	BO	BT	KC	KD	KG	KO	LB	WM	XM
$\phi 50$	40	45	12.5	15	8	70	10	65	5	$\phi 11$	105	80
$\phi 63$	40	45	12.5	15	8	70	10	65	5	$\phi 11$	105	80
$\phi 80$	65	60	15	15	12	95	5	85	10	$\phi 14$	135	105
$\phi 100$	65	60	15	15	12	95	5	85	10	$\phi 14$	135	105
$\phi 125$	77	75	17.5	17.5	14	112	17.5	—	—	$\phi 18$	145	110
$\phi 160$	120	115	22.5	22.5	23	165	22.5	—	—	$\phi 22$	175	130
$\phi 180$	120	115	22.5	22.5	23	165	22.5	—	—	$\phi 22$	175	130
$\phi 200$	120	115	22.5	22.5	23	165	22.5	—	—	$\phi 22$	175	130
$\phi 250$	165	140	25	25	28	215	25	—	—	$\phi 26$	220	170

Unit : mm

BRACKET FOR TA $\phi 50 \sim \phi 80$

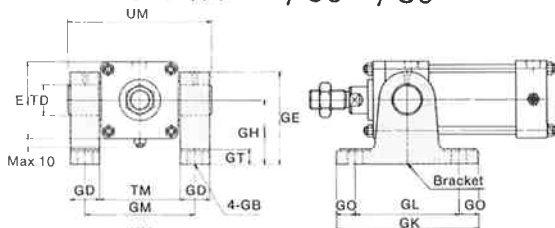

$\phi 100 \sim \phi 250$

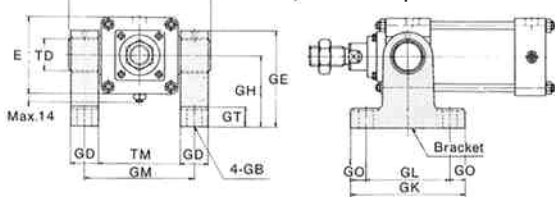

• Refer to TA type for the dimension of cylinder body.

BRACKET FOR TC $\phi 50 \sim \phi 80$

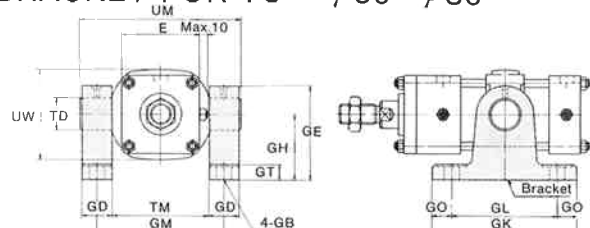

$\phi 100 \sim \phi 250$

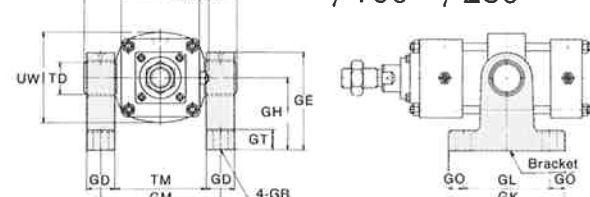

• Refer to TC type for the dimension of cylinder body.

DIMENSIONAL TABLE

Symbol Bore	E	GB	GD	GE	GH	GK	GL	GM		GO	GT	TD	TM		UM		UW
								TA Type	TC Type				TA Type	TC Type	TA Type	TC Type	
$\phi 50$	62	$\phi 12$	23	72	50	110	80	86	99	15	12	$\phi 25_{\substack{H9 \\ e9}}$	63	76	113	126	71
$\phi 63$	76	$\phi 12$	23	72	50	110	80	99	111	15	12	$\phi 25_{\substack{H9 \\ e9}}$	76	88	126	138	86
$\phi 80$	94	$\phi 14$	23	92	70	120	85	118	137	17.5	14	$\phi 25_{\substack{H9 \\ e9}}$	95	114	145	164	104
$\phi 100$	114	$\phi 14$	23	92	70	120	85	137	155	17.5	14	$\phi 25_{\substack{H9 \\ e9}}$	114	132	164	182	128
$\phi 125$	138	$\phi 18$	25	115	85	145	105	164	183	20	25	$\phi 25_{\substack{H9 \\ e9}}$	139	158	189	208	158
$\phi 160$	178	$\phi 22$	36	170	130	185	140	214	236	22.5	25	$\phi 36_{\substack{H9 \\ e9}}$	178	200	250	272	200
$\phi 180$	200	$\phi 22$	36	170	130	185	140	236	264	22.5	25	$\phi 36_{\substack{H9 \\ e9}}$	200	228	272	300	228
$\phi 200$	216	$\phi 22$	36	170	130	185	140	252	282	22.5	25	$\phi 36_{\substack{H9 \\ e9}}$	216	246	288	318	246
$\phi 250$	270	$\phi 26$	45	210	160	215	165	315	349	25	32	$\phi 45_{\substack{H9 \\ e9}}$	270	304	360	394	304

STRONG FORCE TYPE AIR CYLINDER 10A-3

MATERIALS

WEIGHT TABLE

Unit : kgf

Bore mm	Basic weight SD Type	Mounting accessory weight									Rod end attachment weight		Additional weight per 1mm of stroke
		LB Type	FA Type	FB Type	CA Type	CC Type	CB Type	CD Type	TA Type	TC Type	Eye (T)	Clevis (Y) with pin	
φ 50	2.80	0.36	0.40	0.50	0.26	—	0.30	—	1.00	0.55	0.21	0.41	0.00779
φ 63	4.20	0.46	0.55	0.65	0.42	—	0.39	—	1.48	0.70	0.21	0.41	0.00945
φ 80	8.14	0.86	1.36	1.59	1.08	—	0.80	—	2.54	1.16	0.62	1.06	0.0135
φ100	12.29	1.12	1.60	2.20	1.39	—	1.05	—	3.81	1.53	0.62	1.06	0.0178
φ125	17.29	2.00	2.39	2.58	2.68	4.60	2.70	4.61	5.42	2.78	1.24	1.47	0.0340
φ160	32.25	3.22	4.96	5.48	6.40	9.40	6.26	9.40	10.39	5.90	2.40	3.32	0.0421
φ180	41.59	5.69	6.70	7.22	9.22	12.50	9.08	12.40	13.72	6.19	2.40	3.32	0.0549
φ200	47.79	6.12	7.78	8.30	10.50	13.80	10.50	13.70	15.99	7.20	2.40	3.32	0.0591
φ250	92.87	8.38	14.36	15.70	20.40	28.70	20.20	29.00	29.43	12.40	4.62	5.83	0.0755

Calculation formula : Cylinder weight (kgf) = Basic weight + Mounting accessory weight + Additional weight per 1mm of stroke × Cylinder stroke (mm)

Calculation example : Cylinder bore φ100 · LB type · Stroke 100mm 12.29 + 1.12 + 0.0178 × 100 = 15.19kgf

DIFFERENCE BETWEEN 10A-3 AND 10A-2

- 10A-3 is the strong force type with piston rod diameter of 10A-2 thickened.

EXTERNAL SHAPE

● Models marked with of 10A-3 series are not fabricated.

Bore (mm)	φ32	φ40	φ50	φ63	φ80	φ100	φ125	φ140	φ160	φ180	φ200	φ250
Series												
10A-3												
10A-2												

DIFFERENCE OF ROD, ROD END THREAD DIAMETER

Series	Item	Dimension symbol	φ32	φ40	φ50	φ63	φ80	φ100	φ125	φ140	φ160	φ180	φ200	φ250
10A-3	Rod dia.	MM	—	—	φ22	φ22	φ25	φ32	φ40	—	φ50	φ50	φ50	φ63
	Rod and thread	KK	—	—	M18×1.5	M18×1.5	M22×1.5	M27×2	M36×2	—	M42×2	M42×2	M42×2	M56×2
10A-2	Rod dia.	MM	φ12	φ16	φ22	φ22	φ25	φ25	φ32	φ40	φ40	φ40	φ40	φ45
	Rod and thread	KK	M10×1.25	M12×1.25	M16×1.5	M16×1.5	M20×1.5	M20×1.5	M27×2	M36×2	M36×2	M36×2	M36×2	M42×2

The following dimension differs as for all bores.

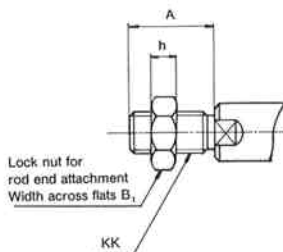

● OTHER DIFFERENCE

	Difference
φ50 ~ φ80	Dimension is similar to 10A-2 series.
φ100 ~ φ250	Body length dimension (Dimension symbol LL) Rod dia. dimension (Dimension symbol MM · D · B) Rod extended dimension (Dimension symbol MF · VF · ZB · ZJ)

- φ100 is modified from retainer method to rod gland bolt set method.
- Piston screw dia. φ50~φ250 is thickened.

Mounting accessories are convertible for 10A-3 and 10A-2.